

# MAINFRAME

## USERS MANUAL

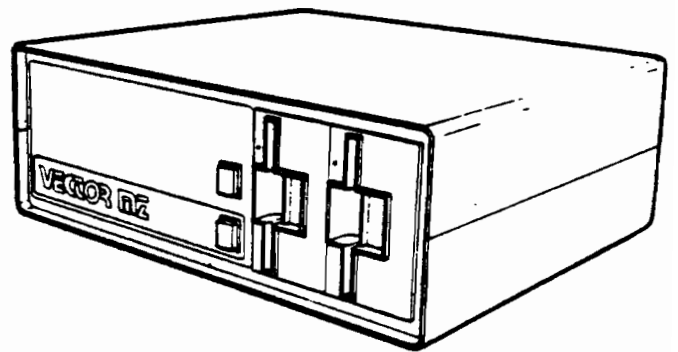
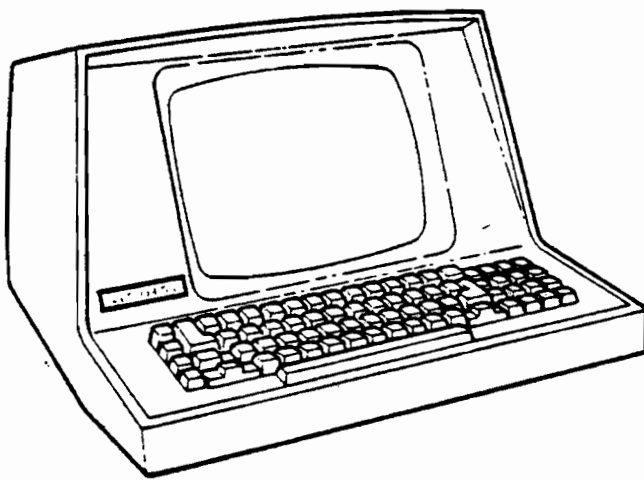

**VECTOR**  
VECTOR GRAPHIC, INC

## REPAIR AGREEMENT

The Mainframe sold hereunder is sold "as is", with all faults and without any warranty, either expressed or implied, including any implied warranty of fitness for intended use or merchantability. However, the above notwithstanding, VECTOR GRAPHIC, INC., will, for a period of ninety (90) days following delivery to customer, repair or replace any Mainframe that is found to contain defects in materials or workmanship, provided:

1. Such defect in material or workmanship existed at the time the Mainframe left the VECTOR GRAPHIC, INC., factory;

2. VECTOR GRAPHIC, INC., is given notice of the precise defect claimed within ten (10) days after its discovery;

3. The Mainframe is promptly returned to VECTOR GRAPHIC, INC., at customer's expense, for examination by VECTOR GRAPHIC, INC., to confirm the alleged defect, and for subsequent repair or replacement if found to be in order.

Repair, replacement or correction of any defects in material or workmanship which are discovered after expiration of the period set forth above will be performed by VECTOR GRAPHIC, INC., at Buyer's expense, provided the Mainframe is returned, also at Buyer's expense, to VECTOR GRAPHIC, INC., for such repair, replacement or correction. In performing any repair, replacement or correction after expiration of the period set forth above, Buyer will be charged in addition to the cost of parts the then-current VECTOR GRAPHIC, INC., repair rate. At the present time the applicable rate is \$35.00 for the first hour, and \$18.00 per hour for every hour of work required thereafter. Prior to commencing any repair, replacement or correction of defects in material or workmanship discovered after expiration of the period for no-cost-to-Buyer repairs, VECTOR GRAPHIC, INC., will submit to Buyer a written estimate of the expected charges, and VECTOR GRAPHIC, INC., will not commence repair until such time as the written estimate of charges has been returned by Buyer to VECTOR GRAPHIC, INC., signed by duly authorized representative authorizing VECTOR GRAPHIC, INC., to commence with the repair work involved. VECTOR GRAPHIC, INC., shall have no obligation to repair, replace or correct any Mainframe until the written estimate has been returned with approval to proceed, and VECTOR GRAPHIC, INC., may at its option also require prepayment of the estimated repair charges prior to commencing work.

Repair Agreement void if the enclosed card is not returned to VECTOR GRAPHIC, INC. within ten (10) days of end consumer purchase.

VECTOR GRAPHIC MAINFRAME  
TABLE OF CONTENTS

REPAIR AGREEMENT	i
PARTS LIST	1
POWER SUPPLY CHECKOUT	4
MINI-FLOPPY POWER SUPPLY PRINTED CIRCUIT BOARD DIAGRAM	6
POWER SUPPLY WIRING DIAGRAM	7
MECHANICAL ASSEMBLY	8
MAINFRAME WIRING DIAGRAM	9

## MAINFRAME PARTS LIST

<u>QTY.</u>	<u>DESCRIPTION</u>
1	CABINET BOTTOM
1	CABINET TOP W/ 14 #8-32X1/4 PAINTED SCREWS
1	FRONT PANEL
1	REAR PANEL
4	RUBBER FEET W/ 4 EACH #4-40X1/2 SCREWS, LOCKWASHERS, HEX NUTS, FLAT WASHERS
1	ROTRON WHISPER FAN OR EQUIVALENT W/ 4 EACH #6-32X1 SCREWS, LOCKWASHERS, HEX NUTS, FLAT WASHERS
1	FAN GUARD
1	FILTERED LINECORD RECEPTACLE W/ 2 EACH #4-40X1/2 SCREWS, LOCKWASHERS, HEX NUTS, FLAT WASHERS
1	ACCESSORY POWER RECEPTACLE W/ 2 EACH #6-32X1/2 SCREWS, LOCKWASHERS, HEX NUTS, FLAT WASHERS
1	FUSEHOLDER W/ 1 EACH LOCKWASHER, HEX NUT, FLAT WASHER
1	FUSE, 5 AMP, SLOW BLOW
1	LINECORD
1	TRANSFORMER W/ 4 EACH #10-32X1/2 SCREWS, LOCKWASHERS, HEX NUTS, FLAT WASHERS
1	ELECTROLYTIC CAPACITOR 150,000 MFD
1	CLAMP FOR ABOVE W/ 1 EACH #6-32X5/8 SCREW, LOCKWASHER, HEX NUT, FLAT WASHER AND 3 EACH #6-32X3/8 SCREWS, LOCKWASHERS, HEX NUTS AND FLAT WASHERS
2	ELECTROLYTIC CAPACITORS, 17,000 MFD
2	CLAMPS FOR ABOVE W/ 2 EACH #6-32X5/8 SCREWS, LOCKWASHERS, HEX NUTS AND FLAT WASHERS AND 4 EACH #6-32X3/8 SCREWS, LOCKWASHERS, HEX NUTS AND FLAT WASHERS
1	BRIDGE RECTIFIER W/ 1 EACH #6-32X1/2 SCREW, LOCKWASHER HEX NUT, FLAT WASHER
2	REVERSE POWER DIODES IN1183RA OR EQUIVALENT W/ 2 EACH 1/4" LOCKWASHERS, 1/4" HEX NUTS, FLAT WASHERS
12	STANDOFFS W/ 24 #6-32X1/4 SCREWS AND 12 LOCKWASHERS
6	100 PIN DUAL 50 EDGE CONNECTORS
4	GUIDE RAILS W/ 4 #8-32X1/2 SCREWS (FRONT) & 4 EACH #6-32X3/8 SCREWS AND LOCKWASHERS (REAR)
12	CARD GUIDES
24	CARD GUIDE LOCKING BUTTONS
1	SWITCH #554-3121-511 AND LENS CAP "RESET"
1	SWITCH #554-1131-511 AND LENS CAP "POWER"
2	BULBS FOR ABOVE
12	CABLE TIES

<u>QTY</u>	<u>DESCRIPTION</u>
1	DISK MOUNTING BRACKET (MZ ONLY)
1	DISK SHIELD BRACKET (MZ ONLY)
2	TERMINAL LUGS:
	1 BLUE #6
	9 BLUE #10
	5 RED #6
	7 RED #10
26'	HOC'UP WIRE:
	1.0' #12 BLACK
	2.5' #12 RED
	1.5' #12 WHITE
	6.5' #16 BLACK
	5.0' #16 VIOLET
	6.0' #16 WHITE
	2.5' #16 YELLOW
	1.0' #20 BLUE
1	MOTHERBOARD WITH MANUAL SOLDER

## VECTOR GRAPHIC MINI-FLOPPY POWER SUPPLY PC BOARD

## PARTS LIST

<u>QTY.</u>	<u>DESCRIPTION</u>
1	PRINTED CIRCUIT BOARD
1	7805 REGULATOR
1	7812 REGULATOR
2	0.1 MFD 50 VOLT CAPACITORS (1 RADIAL, 1 AXIAL)
1	NYLON 4-POSITON PLUG

## HARDWARE

2	1/8" SPACERS
2	#6 SPLIT LOCKWASHERS
2	#6 FLAT LOCKWASHERS
2	#6 HEX NUTS
2	#6-32X3/8 SCREW, PANHEAD SLOT
3	RED #10 TERMINAL LUGS

## WIRE

6'	HOOKUP WIRE:
1'	#20 RED
1'	#20 ORANGE
1'	#20 VIOLET
1'	#20 GREEN
2'	#20 WHITE

## VECTOR GRAPHIC MAINFRAME

## POWER SUPPLY

THIS SECTION IS PROVIDED FOR REFERENCE. YOUR VECTOR GRAPHIC MAINFRAME HAS BEEN COMPLETELY TESTED AT THE FACTORY.

**!CAUTION!**

THIS POWER SUPPLY USES 110V AC, WHICH IS A POTENTIALLY LETHAL VOLTAGE LEVEL. EXTREME CAUTION MUST BE EXERCISED WHEN WORKING WITH THESE CIRCUITS WHEN POWER IS APPLIED. IT IS SUGGESTED THAT THE USER ALWAYS KEEP ONE HAND IN HIS POCKET WHILE WORKING ON THE POWER SUPPLY. NEVER MAKE OHMMETER OR CONTINUITY MEASUREMENTS WHILE POWER IS APPLIED.

PRELIMINARY CHECKOUT (WITHOUT POWER)

DO NOT APPLY POWER DURING THESE TESTS.

REVIEW ALL PREVIOUS WIRING INSTRUCTIONS TO INSURE THAT THE POWER SUPPLY IS WIRED CORRECTLY. CHECK ALL CONNECTORS FOR MECHANICAL INTEGRITY, SUCH AS THE SCREW TERMINALS ON THE ELECTROLYTIC CAPACITORS AND THE MOTHERBOARD. A LOOSE OR UNTERMINATED WIRE CAN CAUSE SERIOUS DAMAGE TO THE COMPUTER AND PRESENT A SAFETY HAZARD TO THE USER.

USING AN OHMMETER, CHECK THE CONTINUITY BETWEEN THE LINECORD RECEPTACLE GROUND TERMINAL AND THE NEGATIVE TERMINAL OF THE 17,000 MFD CAPACITOR. CONTINUITY (0 OHMS) SHOULD BE INDICATED BETWEEN THESE POINTS. NOW MEASURE FROM THE CAPACITOR TO SOME BARE METAL PORTION OF THE CHASSIS. CONTINUITY SHOULD ALSO BE INDICATED HERE.

WITH THE OHMMETER ON THE X1 SCALE, MEASURE ACROSS THE 150,000 CAPACITOR. IF A SHORT IS INDICATED, REVERSE THE LEADS OF THE OHMMETER AND REPEAT THE MEASUREMENT. THE CORRECT INDICATION OF THE OHMMETER WILL BE A SLOWLY INCREASING VALUE OF RESISTANCE (IN THE ORDER OF SECONDS) TO A FINAL VALUE OF 100 OHMS PLUS OR MINUS 20%. IF A SHORT IS INDICATED BOTH TIMES, THEN EITHER THE CAPACITOR IS SHORTED OR THERE IS A WIRING ERROR.

REPEAT THE ABOVE TEST ON EACH OF THE TWO 17,000 MFD CAPACITORS. THE FINAL VALUE OF RESISTANCE FOR THESE TESTS SHOULD BE 820 OHMS PLUS OR MINUS 20%. THEREFORE, ADJUST THE SCALE OF THE OHMMETER ACCORDINGLY. THE RESPONSE TIME WILL BE MUCH SHORTER FOR THESE CAPACITORS.

PRELIMINARY CHECKOUT (WITH POWER)

BEFORE APPLYING POWER TO THE COMPUTER, REMOVE ALL PLUG-IN CIRCUIT BOARDS. INSURE THAT THE FUSE IS INSTALLED AND THAT THE POWER SWITCH IS OFF. CONNECT THE AC LINECORD AND TURN ON THE POWER SWITCH. LISTEN FOR ANY CRACKLING SOUNDS OR VERY LOUD BUZZING IN THE TRANSFORMER. IMMEDIATELY DISCONNECT POWER BY

UNPLUGGING THE LINECORD IF ANY UNUSUAL SOUNDS ARE NOTED OR IF ARCING IS APPARENT.

CORRECT OPERATION OF THE POWER SUPPLY SHOULD BE THE FAN RUNNING AND BOTH PILOT LIGHTS ON. WITH A VOLTMETER CHECK EACH OF THE POWER SUPPLY VOLTAGES. THEY SHOULD BE:

NOMINAL VOLTAGE	ACCEPTABLE LIMITS
+8 VOLTS	+7.5 TO +11 VOLTS
+16 VOLTS	+15 TO +20 VOLTS
-16 VOLTS	-15 TO -20 VOLTS

ANY VOLTAGE READING OUT OF THE ACCEPTABLE LIMITS INDICATES A FAILURE IN THAT CIRCUIT. THE MOST LIKELY FAILURES, AFTER WIRING ERRORS HAVE BEEN ELIMINATED, ARE DEFECTIVE DIODES OR TRANSFORMER.

AFTER THE VOLTAGES HAVE BEEN TESTED AT THE POWER SUPPLY, CAREFULLY CHECK FOR THESE VOLTAGES ON THE MOTHERBOARD. THEY SHOULD BE ON THE FOLLOWING PINS:

BUS VOLTAGE	BUS PIN
+8 VOLTS	1, 51
+16 VOLTS	2
-16 VOLTS	52
GROUND	50, 100

INCORRECT READING HERE COULD DAMAGE CIRCUIT BOARDS WHEN THEY ARE INSTALLED. IF ANY WRONG VOLTAGES ARE FOUND, CAREFULLY CHECK WIRING TO THE MOTHERBOARD.



### MINI-FLOPPY POWER SUPPLY P.C. BOARD

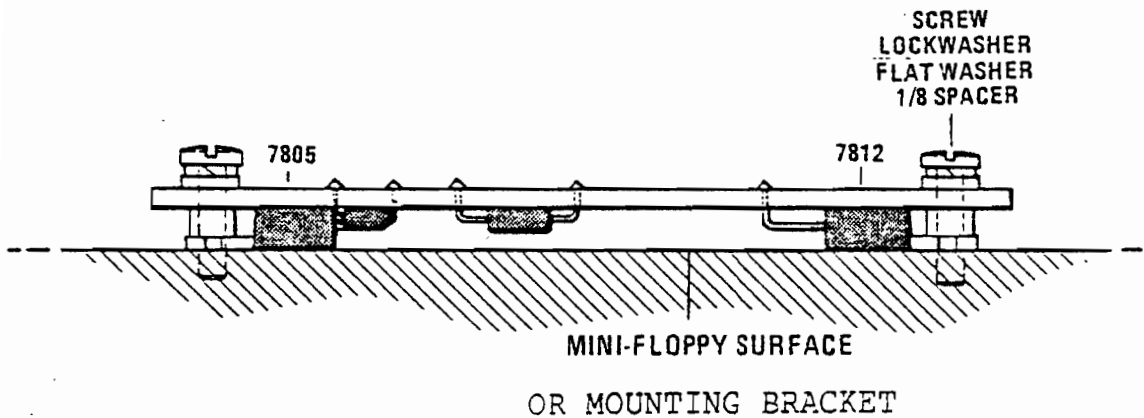
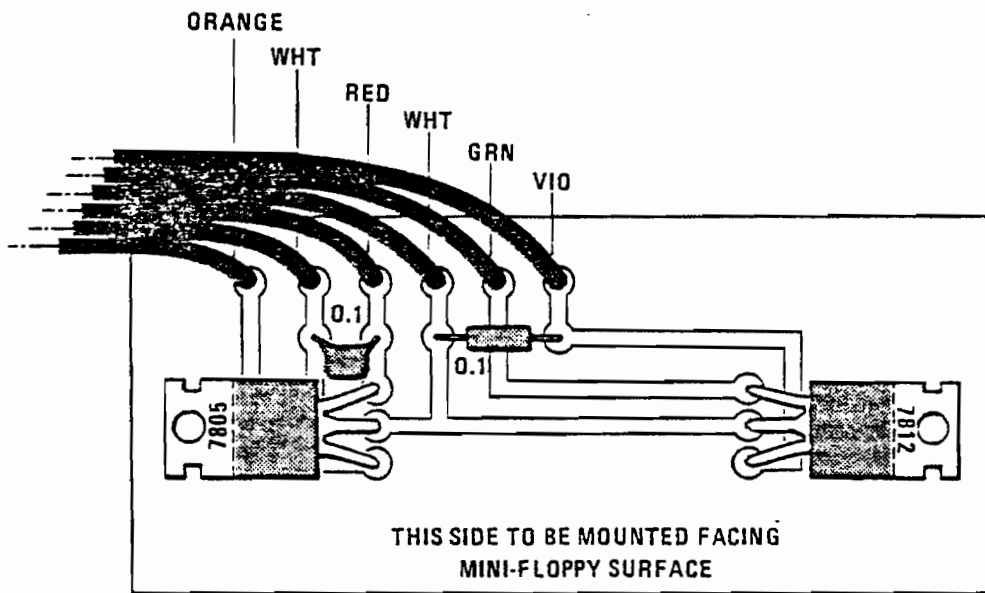
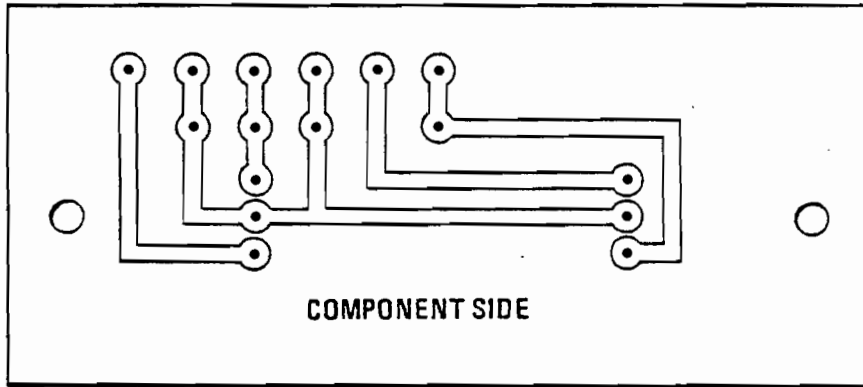

MAINFRAME POWER SUPPLY

ACCESSORY RECEPTACLE

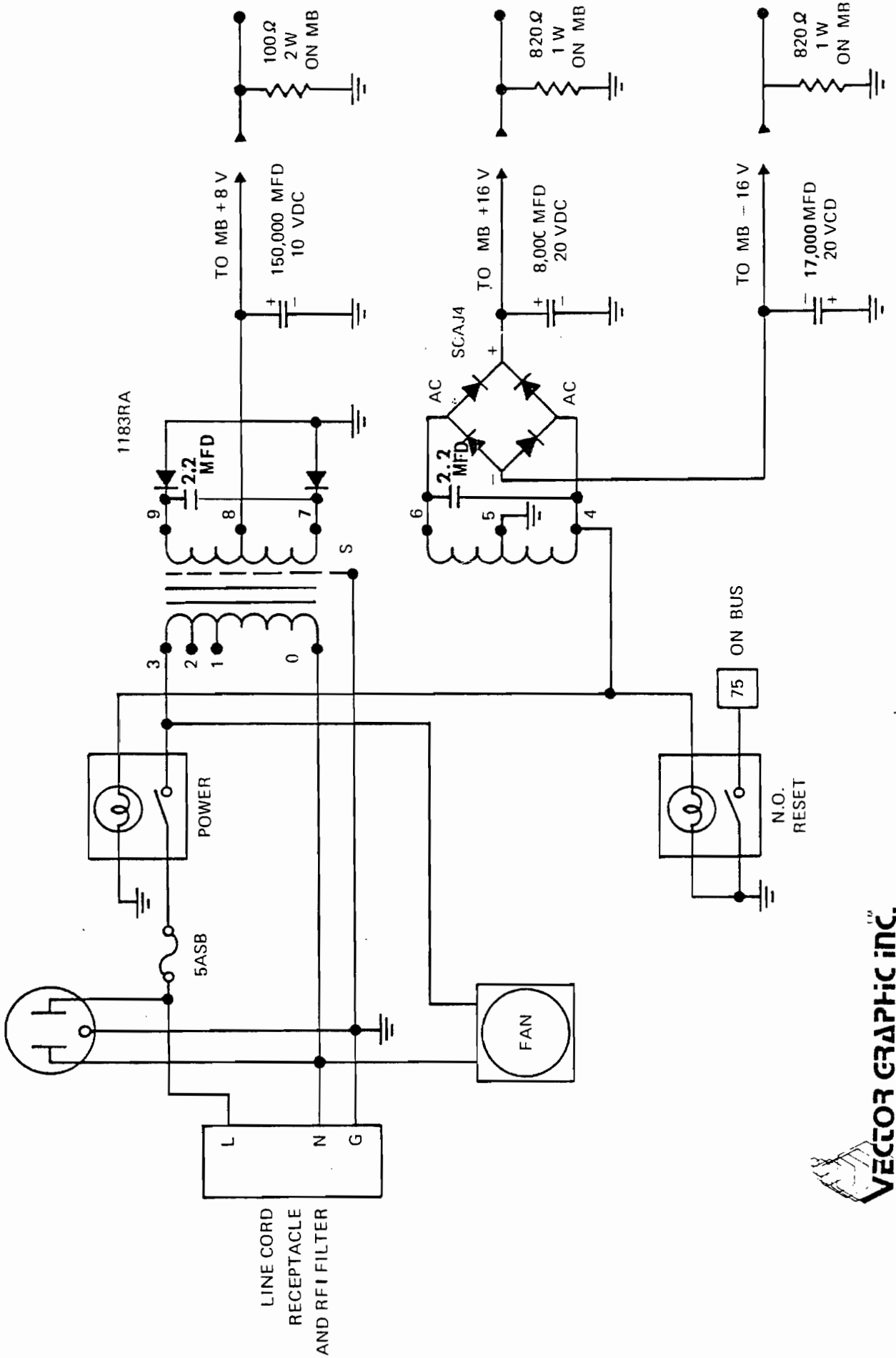

FIGURE 2 - MECHANICAL ASSEMBLY - VECTOR 1 +

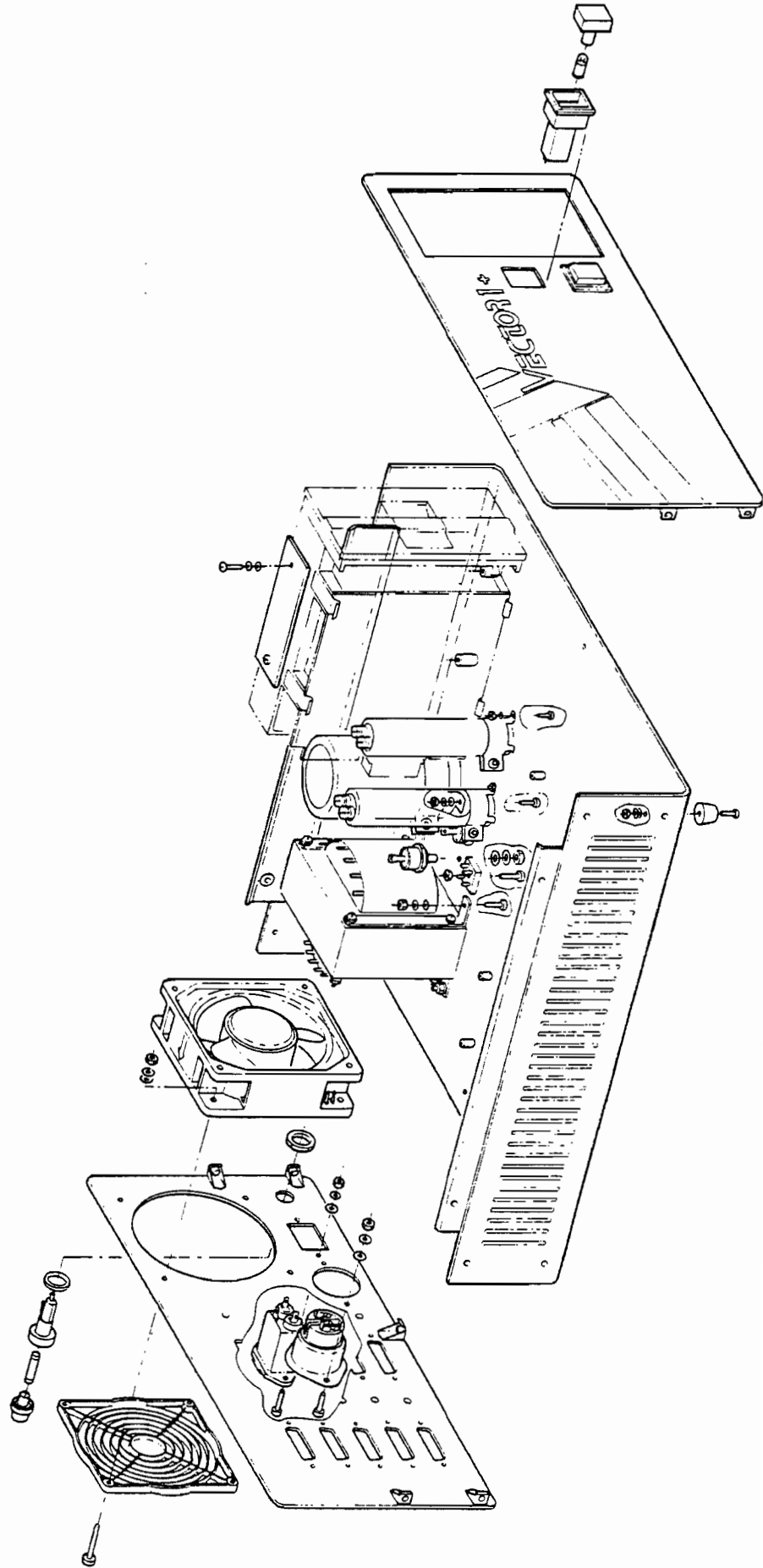

FIGURE 4 -- FRONT PANEL WIRING

FIGURE 5 -- POWER SUPPLY WIRING

FIGURE 3 -- REAR PANEL WIRING

MINI FLOPPY DRIVE (OPTION)

