

Automatic Antenna Tuner FC-30 Installation Instructions

Thank you for your purchase of the model FC-30 Automatic Antenna Tuner, designed specifically for the FT-897 HF/VHF/UHF Transceiver. The FC-30 includes a cooling fan to ensure thermal stability of the critical matching elements within its compact case.

The FC-30 Automatic Antenna Tuner responds to control commands from the FT-897 Transceiver, providing microprocessor-based impedance matching on the 160 through 6 meter Amateur bands. On the HF and 50 MHz bands the impedance matching range is from 16.5Ω to 150Ω (up to 3:1 SWR). Accordingly, the FC-30 should not be expected to match “long wire” type antennas unless you have taken specific design steps to ensure that the impedance presented to the FC-30 is within these specifications.

Please refer to the FT-897 Operating Manual for operating instructions.

Rear Panel Information

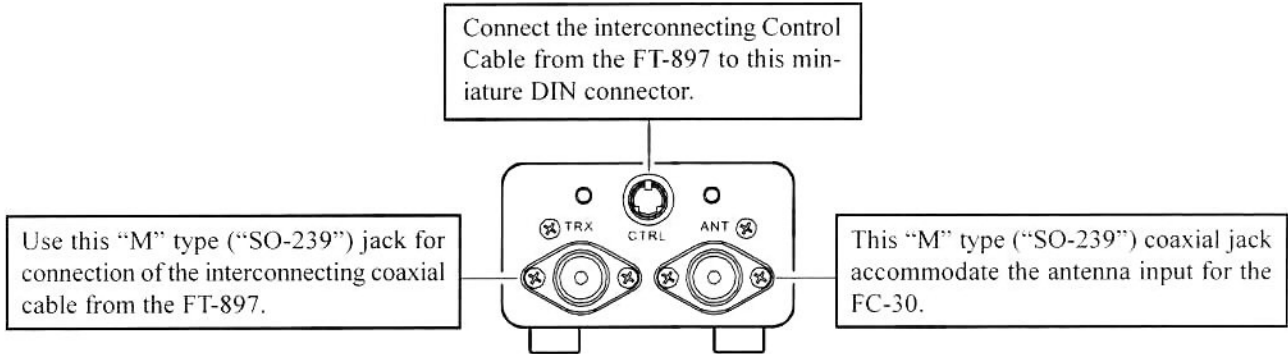

Interconnections to FT-897

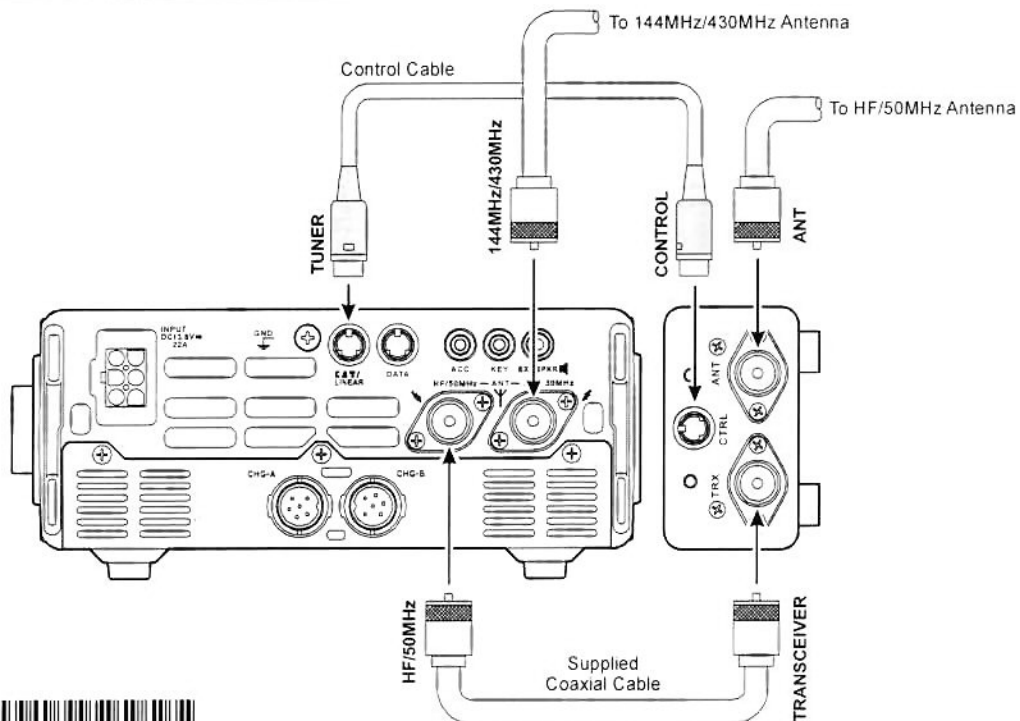

Various setting

By changing the configuration of an internal DIP switch, you may change the RF signal path (to enable the FC-30 both on receive and transmit), and you may also clear all the tuner's memories.

A) By default, the FC-30 is only engaged in the transmit mode. To activate the tuner circuit while receiving.

1. Turn the FT-897 POWER switch OFF.
2. Remove the 6 screws affixing the case of the FC-30, then remove the case.
3. Turn the 8th switch of S1003 to "on."
4. Replace the case, using the 6 screws removed in step (2) above.

B) Memory clear

1. Turn the FT-897 POWER switch OFF.
2. Remove the 6 screws affixing the case of the FC-30, then remove the case.
3. Turn the 4th switch of S1003 to "on."
4. Turn the FT-897 POWER switch ON.
5. LED0 will glow green, then disappear, after a short time.
6. Return the 4th switch of S1003 to "off."
7. Turn the FT-897 POWER switch OFF.
8. Replace the case, using the 6 screws removed in step (2) above.

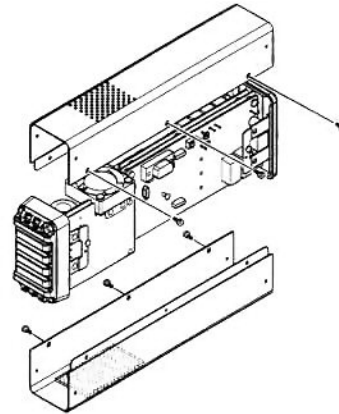

⚠ The bottom case is the case half that has a sponge affixed to the ventilation screen. If the case parts are reversed, the sponge can touch the fan blades, disabling the fan and allowing the FC-30's control circuitry to overheat.

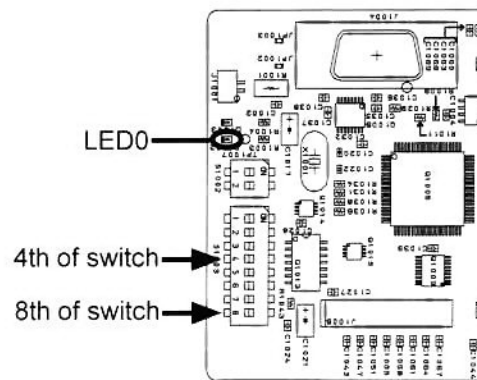

Cautions

○ Please note the default positions of the internal DIP switch components. All switches, except for the 4th and 8th switches of S1003, are for factory setup use only, and they should not be touched. If you accidentally set a switch to the wrong position, please refer to the table below to correct the situation.

S1002		S1003			
No	Switch	No	Switch	No	Switch
1	OFF	1	OFF	5	ON
2	OFF	2	OFF	6	ON
		3	OFF	7	OFF
		4	OFF	8	OFF

- Only connect cables to the FC-30 after switching the transceiver off.
- If the FC-30 doesn't tune even though you have pushed the TUNER switch of FT-897, it may be because the antenna or its coaxial cable have a serious problem (very high or low impedance due to "open" or "short"). Please check the antenna and coax if this happens.
- Do not place any objects next to the ventilator ducts on the FC-30, especially those in the front.

Specifications

FREQUENCY RANGE: 1.8 ~ 30 MHz, 50 ~ 54 MHz
 INPUT IMPEDANCE: 50Ω
 MAXIMUM POWER: 100 Watts
 MATCHED SWR: 1.5:1 or less
 TUNE-UP POWER: 4 W ~ 60 W
 TUNE-UP TIME: 5 seconds or less
 IMPEDANCE MATCHING RANGE:
 1.8 ~ 30 MHz, 50 ~ 54 MHz: 16.5Ω ~ 150Ω
 IMPEDANCE MATCHING MEMORIES: 100 channels
 INPUT VOLTAGE REQUIREMENT: 13.8V ±15% (supplied from transceiver)
 OPERATING TEMPERATURE RANGE: 14° F ~ 122° F (-10 °C ~ +50 °C)
 CASE SIZE (WHD): 3.1" x 1.8" x 10.2" (80 x 45 x 260 mm)
 WEIGHT: 1 kg (2.2 lb.)

Specifications subject to change without notice of obligation.

Supplied Accessories

Coaxial Cable (0.5 m) 1
 Control Cable (0.5 m) 1
 Mounting Screw Assy..... 1

VERTEX STANDARD CO., LTD.

4-8-8 Nakameguro, Meguro-Ku, Tokyo 153-8644, Japan

VERTEX STANDARD

US Headquarters

10900 Walker Street, Cypress, CA 90630, U.S.A.

International Division

8350 N.W. 52nd Terrace, Suite 201, Miami, FL 33166, U.S.A.

YAESU EUROPE B.V.

P.O. Box 75525, 1118 ZN Schiphol, The Netherlands

YAESU UK LTD.

Unit 12, Sun Valley Business Park, Winnall Close
 Winchester, Hampshire, SO23 0LB, U.K.

VERTEX STANDARD HK LTD.

Unit 5, 20/F., Seaview Centre, 139-141 Hoi Bun Road,
 Kwun Tong, Kowloon, Hong Kong

Coil Unit Circuit Diagram

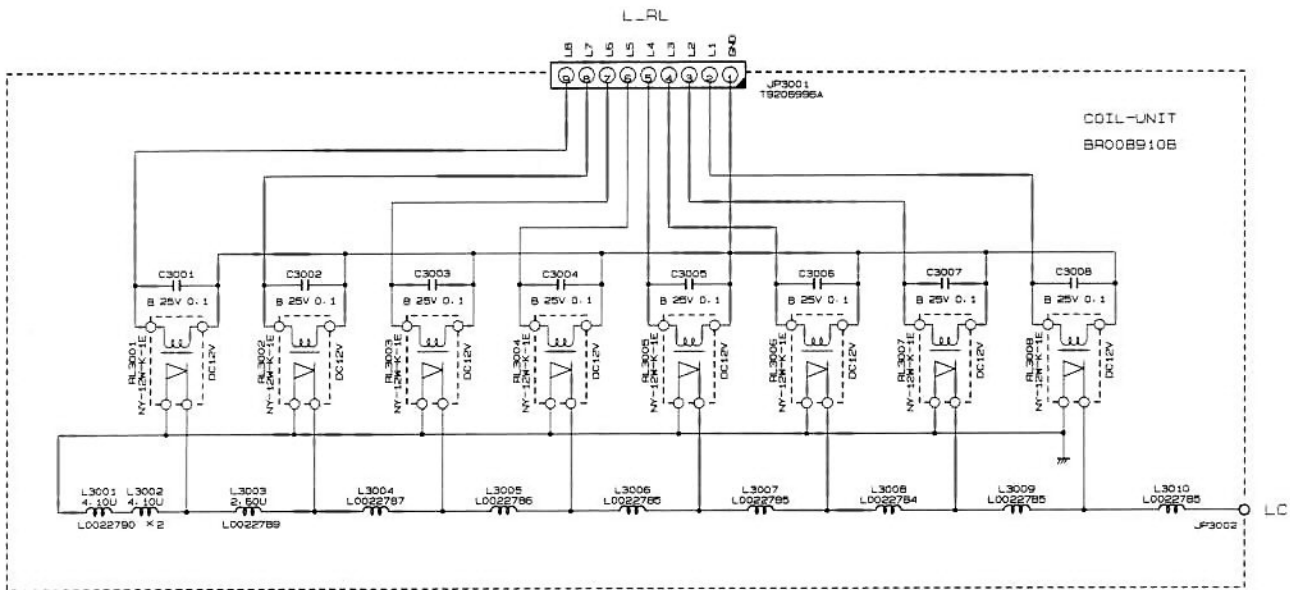

Capacitor Unit Circuit Diagram

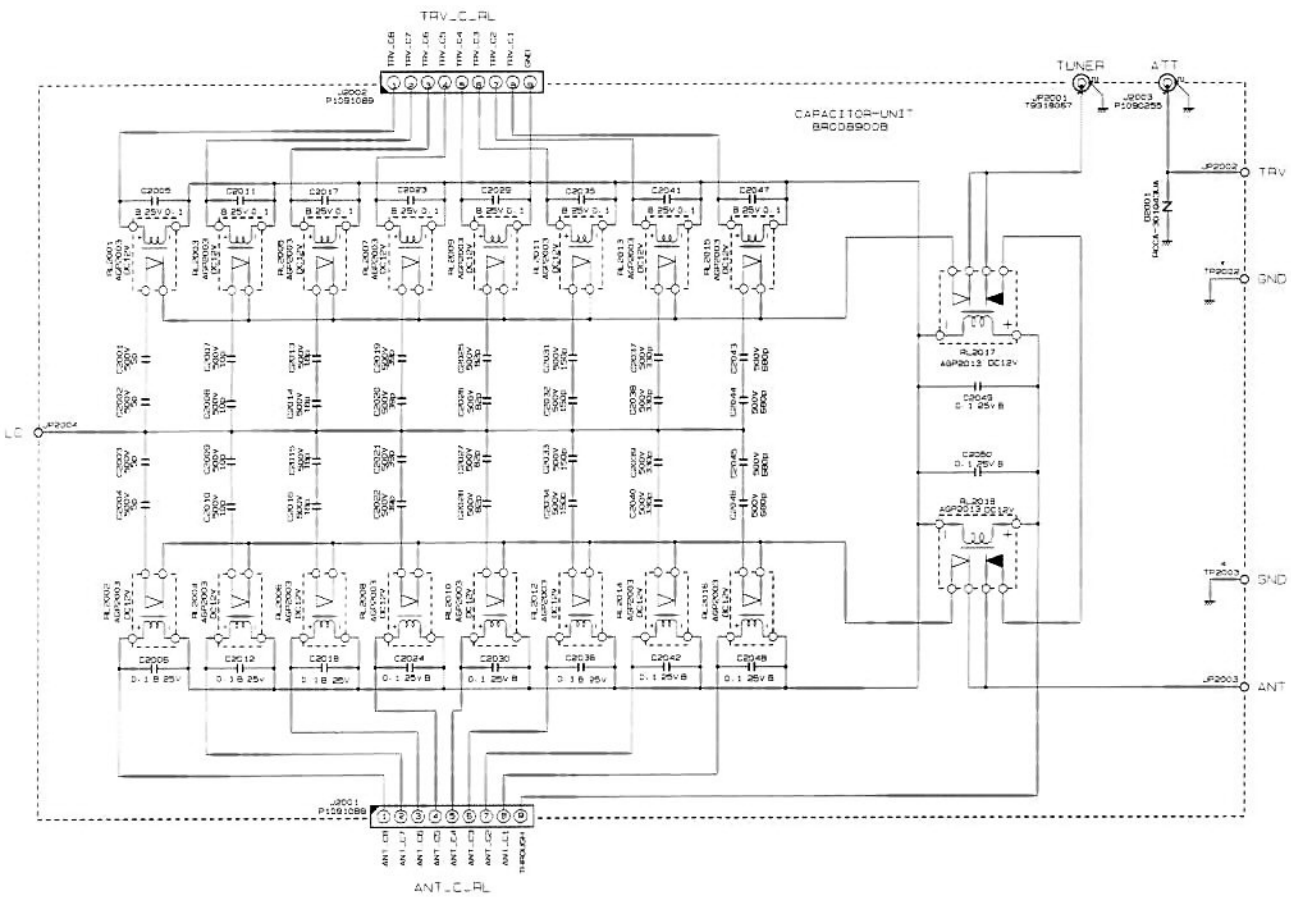

CNTL Unit Circuit Diagram

