

# **YAESU**

## **G-800DXA**

## **G-1000DXA**

## **G-2800DXA**

### **Antenna Rotator & Controller**

### **User Manual**

**VERTEX STANDARD CO., LTD.**

4-8-8 Nakameguro, Meguro-Ku, Tokyo 153-8544, Japan

**VERTEX STANDARD**

**US Headquarters**

17210 Edwards Rd., Cerritos, CA 90703, U.S.A.

**International Division**

8350 N.W. 52nd Terrace, Suite 201, Miami, FL 33166, U.S.A.

**YAESU EUROPE B.V.**

P.O. Box 75525, 1118 ZN Schiphol, The Netherlands

**YAESU UK LTD.**

Unit 12, Sun Valley Business Park, Winnall Close

Winchester, Hampshire, SO23 0LB, U.K.

**YAESU GERMANY GmbH**

Am Kronberger Hang 2, D-65824 Schwalbach, Germany

**YAESU HK LTD.**

11th Floor Tsim Sha Tsui Centre, 66 Mody Rd.,

Tsim Sha Tsui East, Kowloon, Hong Kong

---

## IMPORTANT !

---

The installation of a rotatable antenna on a tower system is a dangerous and potentially life-threatening task, if due care is not taken.

A tower must never be installed in a position where it could fall across power distribution cables in the event of a catastrophic tower failure during a windstorm or earthquake.

The control cable attached to this rotator could, in the event of a nearby or direct lightning strike, carry lethal voltages down the cable and into your home. Yaesu strongly recommends the installation of suitable lightning arrestors on all control cables and coaxial lead-in cables from your antenna installation. See your dealer for details of available lightning-protection devices.

If an electrical storm should be reported in your area, quickly unplug the control cable from the rear of the rotator's controller box, and disconnect the AC cable from the wall outlet. Disconnect the coaxial cable(s) from the antenna(s) as well. *Do this only if the lightning is not in your immediate area, as you could be killed instantly if lightning should strike while you are holding a cable.*

If you have any doubts about your ability to install this rotator safely, enlist the services of a professional antenna installation company.

# YAESU

## G-800DXA G-1000DXA G-2800DXA

### Heavy-Duty Antenna Rotator & Controller

The Yaesu **G-800DXA**, **G-1000DXA** and **G-2800DXA** are designed to rotate large tower-mounted amateur and professional antenna arrays under remote control from the station operating position. The clamshell rotator design utilizes 100 7/16-inch dual-stacked circumferential ball bearings to distribute load over the full diameter of the housing. This design minimizes stress and wear, and practically eliminates the possibility of destructive water entry: there is no shaft hole in the top of the housing.

Instead of the usual AC motor drive used in older rotator designs, the **G-800DXA**, **G-1000DXA** and **G-2800DXA** use a variable-voltage DC motor, obviating the need for a large starting capacitor with its potential for failure exposed to outside temperature variations. The factory-lubricated rotator unit is housed in melamine resin-coated die-cast aluminum, intended to provide maintenance-free operation under all climatic conditions. A mast alignment gauge on the rotator housing simplifies accurate mechanical alignment during installation.

The handsome desktop controller matches the design of modern transceivers, providing 360° radial indication of actual antenna bearing azimuth. You can select rotating speeds from 40 to 100 seconds per (360°) rotation (**G-800DXA** and **G-1000DXA**, **G-2800DXA**: 50 to 120 seconds per (360°) rotation), and can preset a desired heading for the rotator, to which it then turns automatically.

In the **G-2800DXA** model, when a fast rotating speed is selected, special "auto slow start" and "auto slow stop" features avoid sharp jolts to the antenna array and tower.

Activating the rotator causes it to begin turning at slow speed. As the antenna approaches the desired heading rotation automatically slows before bringing the antenna to a gentle stop. The operator may select the stopper heading (the bearing through which the rotator cannot be turned) most convenient for his location and operation, allowing full rotation through north, south or both, if desired. In any case, 90° overlapping rotation allows rotation through the selected stopper heading (450° total rotation).

The rotator is intended for mounting inside a support tower (not supplied), at least 1 meter from the top, with an optional (Yaesu model **GS-680U**) thrust bearing above.

The **G-800DXA** and **G-1000DXA** includes one mast clamp and related hardware, plus plug connectors for both the rotator and controller. A six conductor cable of the necessary length must be supplied by the owner. The **G-2800DXA** model includes one mast clamp and related hardware, plus a 40 m length control cable, to simplify installation.

The **GS-232A** Computer Control Unit is available as an option, allowing positioning of the antenna by a personal computer, via an RS-232 serial interface.

Please read this manual through carefully before installing the rotator, to acquaint yourself with the procedures that will be required, and to ensure that you have all necessary items for your installation.



# Controller Front Panel

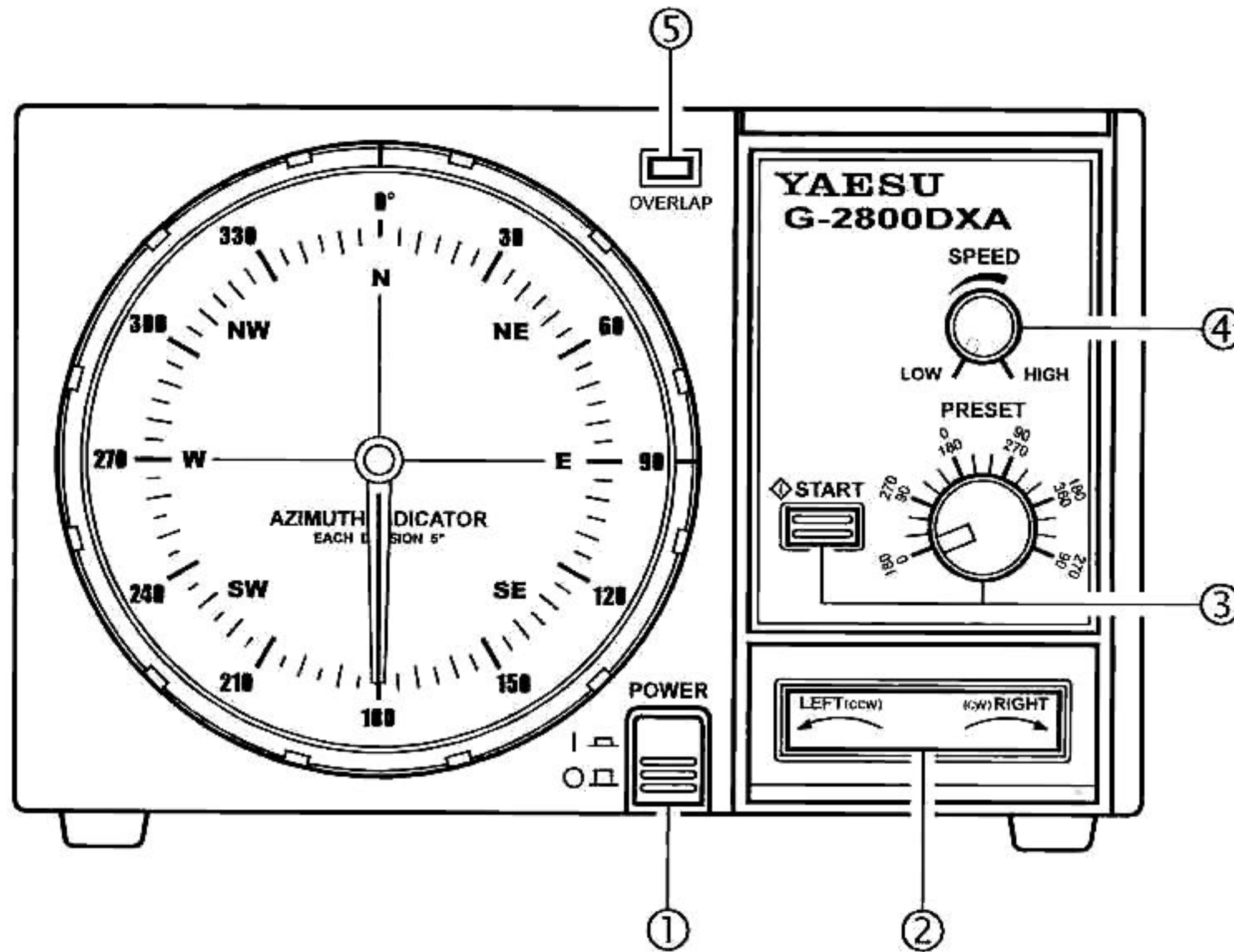

## ① POWER Switch

Press this switch to turn the controller on to rotate the antenna. Turn it off when the rotator is not in use.

## ② LEFT/RIGHT Seesaw Switch

Press the **LEFT** side of this switch to rotate the antenna counter-clockwise (CCW). Press the **RIGHT** side to rotate the antenna clockwise (CW).

## ③ PRESET Control and START Switch

Set the **PRESET** control to the desired antenna heading according to the *outer* angular scale (180 ~ 270) around this control, then press the (momentary) **START** switch to activate automatic rotation to the desired heading. You can press the **LEFT/RIGHT** switch to abort preset operation.

*Note:* If you change the rotator starting position to the 0° (N: North), set the **PRESET** control to the desired antenna heading according to the *inner* angular scale (0 ~ 90) around this control.

## ④ SPEED Control

Set this control for the desired rotating speed between approximately 30 and 100 seconds per 360° revolution.

## ⑤ OVERLAP Indicator

This red LED glows when the antenna is rotated beyond about 180° (to 270°) from its original installation direction (180°). Check this indicator before rotating the antenna clockwise, and turn the antenna counter-clockwise to the desired position if the indicator is on.

# Controller Rear Panel

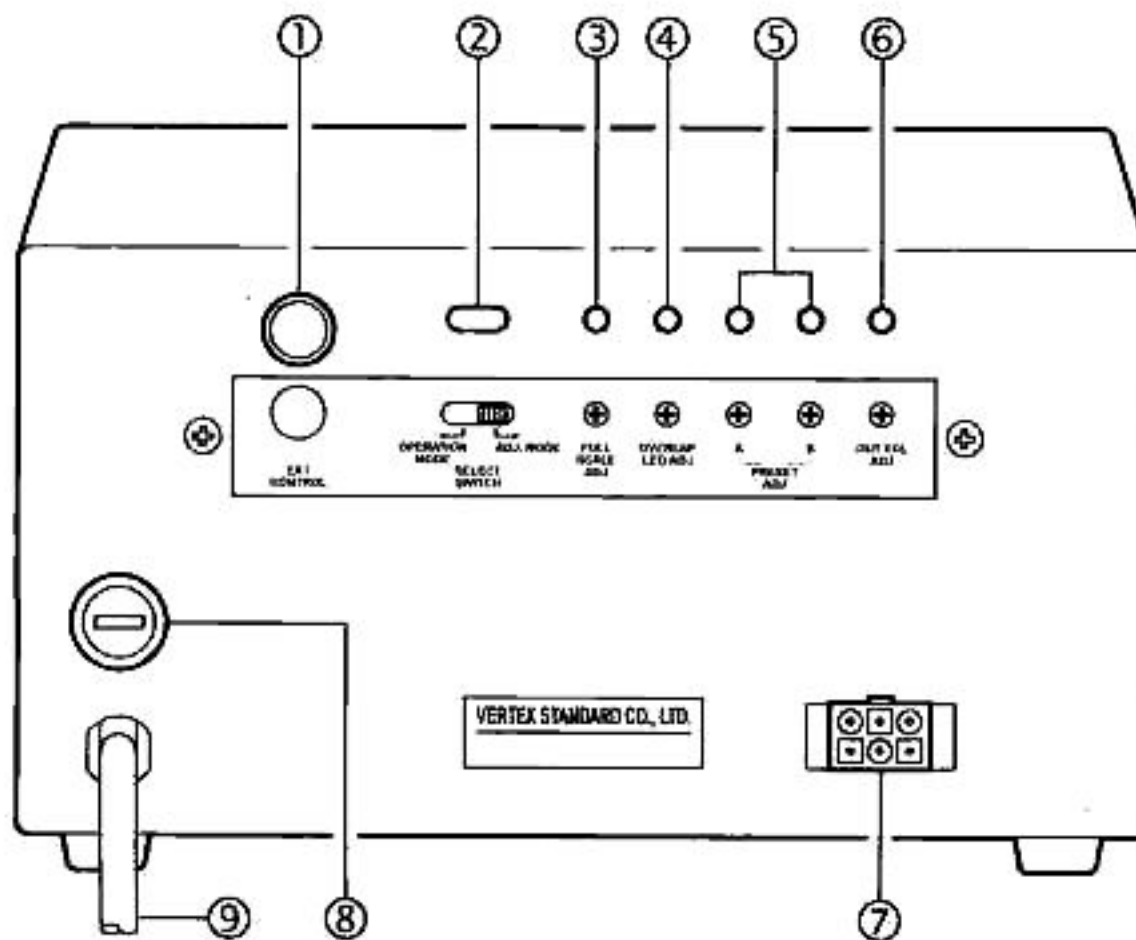

## ① EXT CONTROL Connector

This 6-pin mini-DIN connector is used for connection to the optional **GS-232A** Computer Control Unit.

## ② SELECT SWITCH

Set this switch to the "ADJ. MODE" position while calibrating the internal adjustments of the controller. During normal operation, however, set this switch to the "OPERATION MODE" position.

## ③ FULL SCALE ADJ Potentiometer

This control calibrates the maximum rotation angle (range) of the azimuth indicating needle to match the maximum angle of the rotator.

## ④ OVERLAP LED ADJ Potentiometer

This control calibrates the **OVERLAP** Indicator to match the azimuth indicating needle.

## ⑤ PRESET ADJ (A & B) Potentiometers

These controls calibrate the angle of the **PRESET** control on the front panel to match the azimuth indicating needle. Pot. **A** should be adjusted only near the 180° position, and Pot. **B** only near the 270° (450°) position.

## ⑥ OUT VOL ADJ Potentiometer

This control presets the voltage range at pin 4 of the 6-pin mini-DIN **EXT CONTROL** Connector, for calibration of the A-to-D converter on the (optional) **GS-232A** Computer Control Unit.

## ⑦ Rotator Control Cable Jack

The supplied control cable from the rotator connects to this 6-pin jack.

## ⑧ FUSE Holder

This holder requires a 2-A fuse for 117V AC, and a 1-A fuse for 220V AC. If the fuse is blown, replace only with a fuse of the same rating.

## ⑨ AC Cable

Connect this cable to the AC mains supply or wall outlet. The AC line voltage must match that on the label.

# Antenna Considerations

The types of antennas that can be attached to this product differ widely, depending on the installation method, local terrain, and the maximum expected wind speeds at your location.

The following pages described typical antennas which are acceptable for installation with the **G-800DXA**, **G-1000DXA** or **G-2800DXA**. The discussion below assumes maximum wind speeds of 30 meters per second, and it is recommended that you include a safety margin of at least 40% to account for higher wind gusts or other factors which might potentially cause damage to your installation.

## POLE-MOUNTED ANTENNAS

Mounting of the rotator on a pole or mast results in a significant de-rating of the size of the antenna which can be mounted, due to the tremendous bending forces applied to the rotator's clamps. For pole mounting, the product of multiplying the [Antenna Wind Load Area (in m<sup>2</sup>)] by the [Height of the Antenna Mast (in m)] must be *less than 0.45* (**G-800DXA/1000DXA**) or *0.8* (**G-2800DXA**). See below Table and Figure.

$$[\text{Antenna Wind Load Area}] \times [\text{Height of Antenna Mast}] = \begin{matrix} 0.45 \text{ (G-800DXA/1000DXA)} \\ 0.8 \text{ (G-2800DXA)} \end{matrix}$$

Refer to the antenna manufacturer's specification sheet for determining the weight and the surface area of the proposed antenna.

**Example** For a 14 MHz 3-element Yagi of Surface area of 0.7 m<sup>2</sup> (see Table 1), the above specifications for pole mounting will be met if the antenna is mounted on a mast not longer than 0.3 m (0.7 m<sup>2</sup> x 0.3 m = 0.21 < 0.27 [0.45 x 40% safety margin]: **G-800DXA/1000DXA**), or 0.6 m (0.7 m<sup>2</sup> x 0.6 m = 0.42 < 0.48 [0.8 x 40% safety margin]: **G-2800DXA**).

**Advice** We recommend that your antennas/mast should not exceed 60% of the maximum rating, to ensure a safety margin.

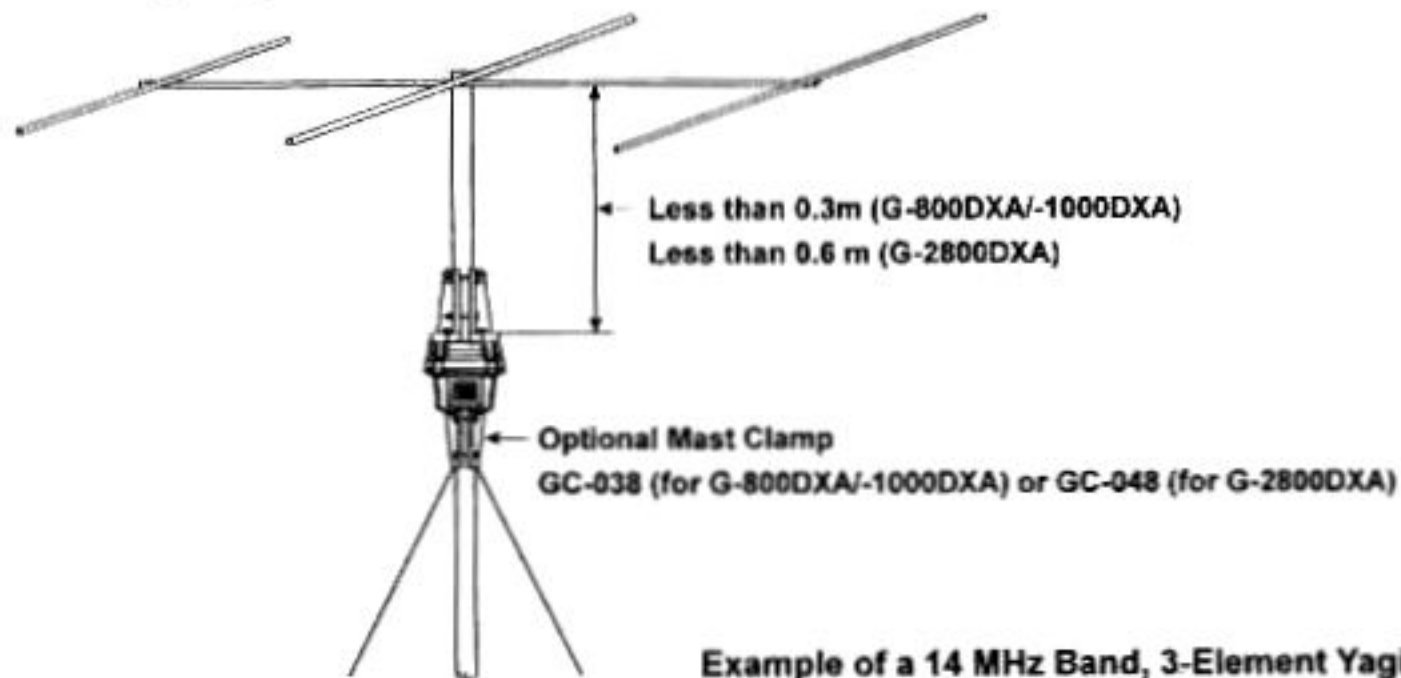

Example of a 14 MHz Band, 3-Element Yagi Antenna

Wind Loading Areas for Common Antennas (Typical)

Band (MHz)	Elements	Area (m <sup>2</sup> )	Band (MHz)	Elements	Area (m <sup>2</sup> )	Band (MHz)	Elements	Area (m <sup>2</sup> )
7	2-element	2.2	28	3-element	0.3	50	4-element	0.25
7	1-element, w/loading coils	0.2	28	4-element	0.42	50	5-element	0.3
7	2-element, w/loading coils	0.6	28	5-element	0.6	50	6-element	0.37
7	3-element, w/loading coils	1.1	28	2-element, Swiss Quad	0.3	50	2-element, Swiss Quad	0.3
14	3-element	0.7	7/14	3-element, trapped	0.5	144	10-element	0.2
14	4-element	1.2	7/14	4-element, trapped	0.8	144	10-element, stacked	0.44
14	5-element	1.7	14/21	3-element, trapped	0.4	144	10-element, x 4	0.95
21	3-element	0.45	14/21	4-element, trapped	0.5	144	10-element, x 4 x 2	2.0
21	4-element	0.6	21/28	3-element, trapped	0.3	430	12-element	0.06
21	5-element	0.8	21/28	4-element, trapped	0.4	430	12-element, stacked	0.12
21	6-element	1.3	14/21/28	3-element, trapped	0.4	430	12-element, x 4	0.3
21	2-element, Swiss Quad	0.3	14/21/28	4-element, trapped	0.5	430	12-element, x 4 x 2	0.6



# Antenna Considerations

## TOWER-MOUNTED ANTENNAS

In the preferred tower-mounting configuration, the antenna Wind Loading Area must be *less than* 2 m<sup>2</sup> (G-800DXA), 2.2 m<sup>2</sup> (G-1000DXA) or 3 m<sup>2</sup> (G-2800DXA), and the "K" factor (see below) must *not exceed* 180 (G-800DXA), 230 (G-1000DXA) or 950 (G-2800DXA), where  $K = [\text{Antenna Turning Radius (m)}] \times [\text{Antenna + Mast Weight (kg)}]$ .

MODEL	G-800DXA	G-1000DXA	G-2800DXA
Wind Loading Area	2 m <sup>2</sup>	2.2 m <sup>2</sup>	3 m <sup>2</sup>
"K" Factor	180	230	950

Refer to the antenna manufacturer's specification sheet for determining the turning radius and weight of the antenna.

**Example** In this example, mount the following antennas stacked on a 6 kg mast.

- (1) 14/21/28 MHz 5-element Yagi of Turning Radius 5.6 m, Weight of 26 kg, and Surface area 0.7 m<sup>2</sup>
- (2) 18 MHz 3-element Yagi of Turning Radius 5.0 m, Weight of 14 kg, and Surface area 0.7 m<sup>2</sup>
- (3) 50 MHz 5-element Yagi of Turning Radius 2.6 m, Weight of 4.5 kg, and Surface area 0.3 m<sup>2</sup>

**Note:** In such "Christmas Tree" installations, compute the mast weight separately for each antenna, using the relative heights of the antennas to apportion the mast weight.

The antenna system K factor, then, is the sum of the three antenna K factors:

$K^1 = K$  factor of 14/21/28 MHz 5-element Yagi.

$$K^1 = \text{Turning Radius (5.6 m)} \times \text{Weight (26 kg + 2 kg)} = 156.8$$

$\downarrow$                        $\downarrow$   
 Antenna Weight    Mast Weight (6 kg/3)

$K^2 = K$  factor of 18 MHz 3-element Yagi.

$$K^2 = \text{Turning Radius (5.0 m)} \times \text{Weight (14 kg + 2 kg)} = 80$$

$\downarrow$                        $\downarrow$   
 Antenna Weight    Mast Weight (6 kg/3)

$K^3 = K$  factor of 50 MHz 5-element Yagi.

$$K^3 = \text{Turning Radius (2.6 m)} \times \text{Weight (5 kg + 2 kg)} = 18.2$$

$\downarrow$                        $\downarrow$   
 Antenna Weight    Mast Weight (6 kg/3)

$$K^{\text{TOTAL}} = K^1 + K^2 + K^3 = 156.8 + 80 + 18.2 = 255$$

The antenna system Wind Loading Area is: 0.7 m<sup>2</sup> + 0.7 m<sup>2</sup> + 0.3 m<sup>2</sup> = 1.7 m<sup>2</sup>

The Wind Loading Area (1.7 m<sup>2</sup>) is within the specifications for the G-800DXA, G-1000DXA and G-2800DXA, but the net K factor (255) can only be met by the G-2800DXA. Therefore, the above antenna system should only be mounted using a G-2800DXA.

**Advice** We recommend that your antennas/mast should not exceed 60% of the maximum rating, to ensure a safety margin.

Sq. Ft	m <sup>2</sup>	Sq. Ft	m <sup>2</sup>
1	0.093	12	1.115
2	0.186	13	1.208
3	0.279	14	1.301
4	0.372	15	1.396
5	0.465	16	1.486
6	0.557	17	1.579
7	0.650	18	1.672
8	0.743	19	1.765
9	0.836	20	1.858
10	0.929	21	1.951
11	1.022	22	2.044

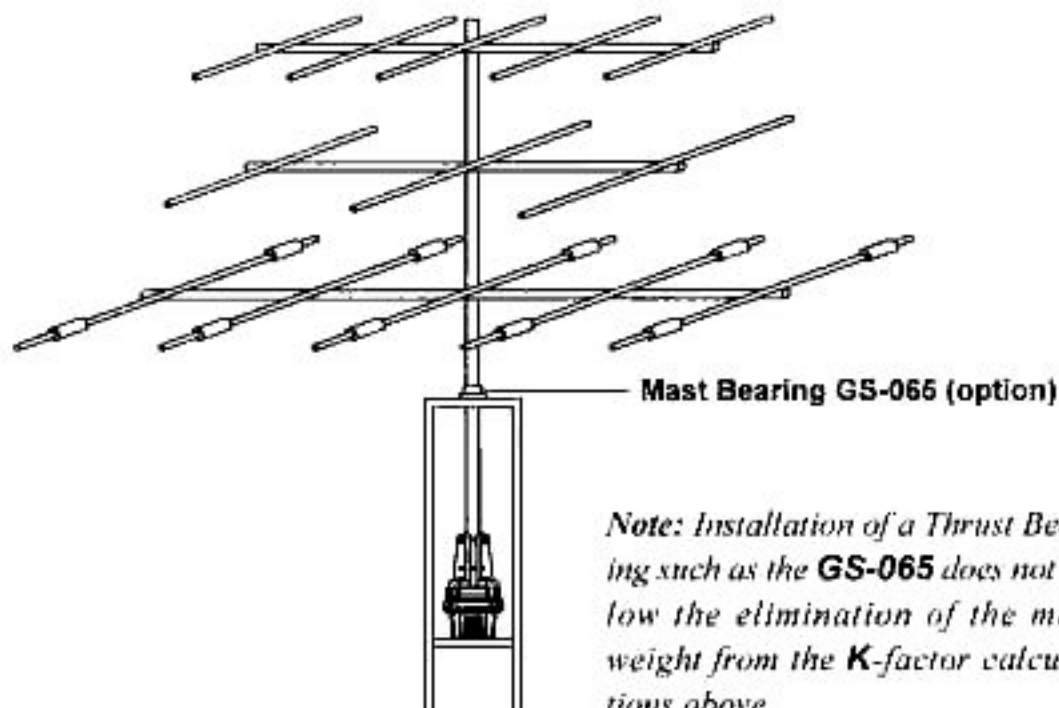

# Control Cable Installation

Before installing the rotator, mast, and antenna, prepare the rotator control cable and *test rotator system performance on the ground*. Potential alignment, cabling, or other problems can quickly be resolved on the ground; once a rotator is mounted, however, troubleshooting may require that the tower be climbed and/or the rotator be removed and lowered to the ground!

## CONTROL CABLE PREPARATION (G-800DXA/-1000DXA)

In the **G-800DXA** and **G-1000DXA** models, the user must supply and prepare the control cable, per the simple instructions below.

The control cable to be used should have six stranded conductors of at least 0.5 mm (#20 AWG) diameter if the cable is shorter than 40 m in length (125'); if the cable is longer than 40 m, use conductors with a diameter of 0.75 mm (#18 AWG) or larger.

1. Disassemble the supplied round plug: slide off the rubber boot, remove the setscrew from the shell using a small screwdriver, then unscrew the shell from the plug. Save the setscrew in a safe place until step 10, so you don't lose it.
2. Slide the rubber boot and the round shell over the "rotator" end of the cable. Leave enough cable protruding to allow easy dressing the end of the cable.
3. Using special care to avoid nicking the insulation of the individual wires, strip back 15 mm (about 5/8") of the outer jacket of the cable from both ends. Now strip 5 mm (about 3/16") of insulation from each wire, being careful not to nick the conductors.
4. Solder the wires to the round plug pins, noting the color of the wire and the number associated with each pin for reference later. **Pin 7 of the round connector is not used!** Confirm that all solder joints are firm and cleanly made, as this part of the cable will be difficult to access once the rotator is installed on top of the tower. Do not slide the shell onto the connector at this time.
5. Crimp the supplied pin contacts onto the wires on the opposite end of the cable, per the illustration on the next page.
6. Referring to your notes of the wire color at each pin of the round (rotator end) connector, insert the pins into the rectangular plug at the opposite (controller) end of the cable. Be sure that each wire from the round connector is routed to the corresponding pin number in the rectangular connector (i.e. 1 to 1, 2 to 2, etc.).
7. Temporarily connect the round plug to the rotator, and the rectangular plug to the controller. Make sure that the **POWER** switch on the controller is set to "OFF," then plug the controller's AC cable into your station's AC outlet.
8. Set the controller's **POWER** switch to "ON." The pilot lamps on the controller should become illuminated, and the meter needle on the controller may rotate so as to align itself with the current position of the rotator (remember the two units have not been aligned with each other).
9. Press the **LEFT** (rotation) side of the seesaw switch, and confirm that the rotator (when viewed from the top) and the controller's needle turn counter-clockwise together. Stop rotation, then press the **RIGHT** (rotation) side of the seesaw switch, and confirm that the rotator and indicator needle turn clockwise. If rotation does not occur as indicated, turn the **POWER** switch "OFF," and re-check your cable connections.
10. If the rotator and controller are working as described, replace the plug shells, setscrew, and rubber boot (removed in step 1).



# Control Cable Installation

## CONTROL CABLE PREPARATION (G-800DXA/-1000DXA)

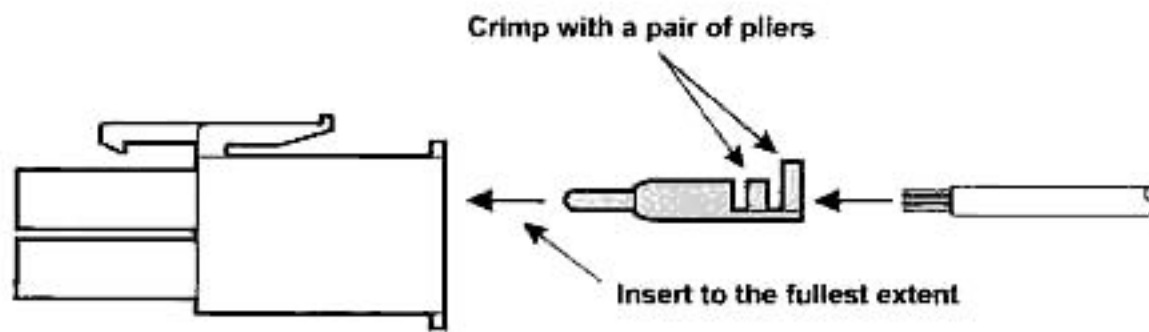

**Assembly of 6-pin Plastic Connector**

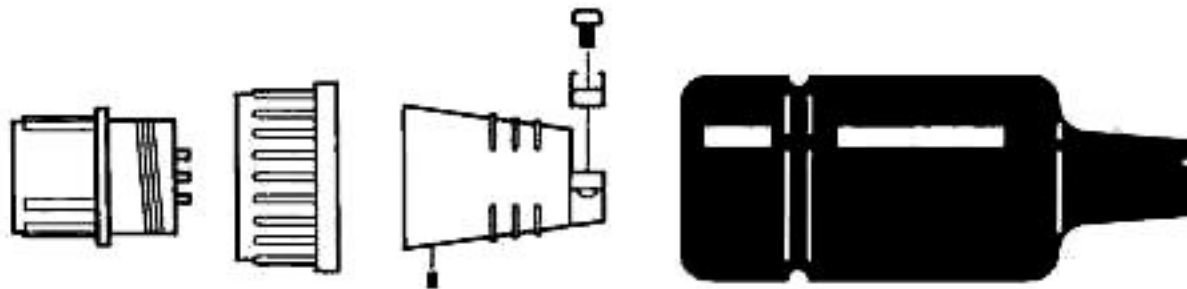

**Assembly of 7-pin Metal Connector**

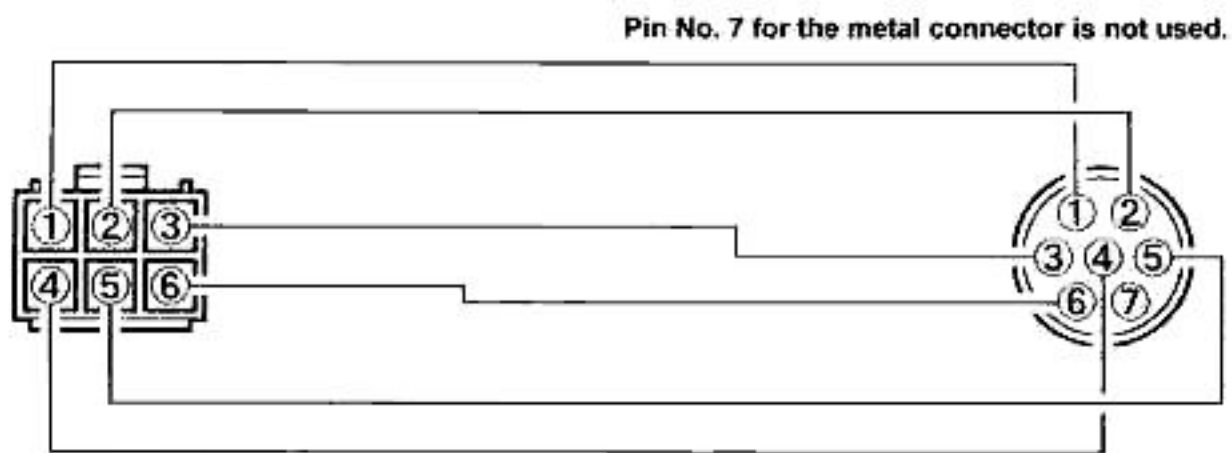

**Wiring for the control cable (identical numbers to be connected)**

# Mounting the Rotator and Antenna

## INDOOR PERFORMANCE CHECK AND ALIGNMENT

1. Temporarily connect the control cable between the rotator unit and the controller.
2. Turn the **SPEED** control fully counter-clockwise, and set the **SELECT SWITCH** on the rear panel to the *right* (**ADJ. MODE**) position.
3. Check to be sure that the **POWER** switch on the controller is set to "OFF," then plug the controller's AC cable into your station's AC outlet.
4. Set the controller's **POWER** switch to "ON." Verify that the controller's pilot lights have become illuminated.
5. Press the **LEFT** (rotation) side of the seesaw switch, and continue to hold it until the rotator reaches the counter-clockwise position where it automatically stops ("Left" represents counter-clockwise rotation when the rotator is viewed from the top).
6. When the rotator has reached the left "stop" position, release the **LEFT** switch, and check to see if the controller's indicator needle is pointing to 180° (S: South).  
If the indicator needle is out of alignment, grasp the edge of the bezel around the bearing window, turn it 10° counter-clockwise, and pull it off. Then, grasp the needle at its center and pull it straight off, replace the needle to 180° (straight down), and replace the bezel.
7. Just above the round connector jack on the rotator unit, you will observe two raised calibration marks (one each on the "rotating" bell and "fixed" base of the rotator). These two marks should be directly aligned with each other. If not, place a small piece of masking tape on the rotating bell and the fixed base of the rotator unit, and make a calibration mark will be used to verify the amount of rotation in the next step.
8. Press the **RIGHT** (rotation) side of the seesaw switch, and continue rotating to the right until the calibration marks (from step 7) are again precisely aligned. Now check the indicator needle, which should also have rotated fully 360° so as to be pointing exactly to 180°.  
If the indicator needle is not pointing exactly to 180°, go to the rear panel of the controller, and use a small screwdriver to adjust the **FULL SCALE ADJ** potentiometer (see the drawing to the right) so that the indicator needle points exactly to 180°.
9. Press the **RIGHT** switch again, and continue rotation to the right. You should observe the **OVERLAP** LED becoming illuminated as rotation passes the 180° point.  
If the **OVERLAP** LED does not light up at the 180° position, the **OVERLAP LED ADJ** potentiometer (on the rear panel of the controller) may be used to align the illumination threshold to the 180° point.
10. Check to verify that rotation automatically stops at approximately 270° (West; representing a total rotation range of 450° from the original starting point).
11. Press the **LEFT** and **RIGHT** (rotation) switches a few more times, verifying that rotation appears to be normal. If so, press the **LEFT** or **RIGHT** (rotation) switch to set the rotator to 270° (West).
12. Set the **PRESET** control to 180° (fully counter-clockwise), and press the **START** switch. The rotator should rotate counter-clockwise, and stop exactly at 180°.  
If not, go to the rear panel of the controller, and use a small screwdriver to adjust the **PRESET ADJ A** potentiometer so that the rotator stops at exactly 180°.
13. Set the **PRESET** control to 270° (fully clockwise), and press the **PRESET** switch. The rotator should rotate clockwise, and stop at exactly 450° (270°; West).  
If not, go to the rear panel of the controller, use a small screwdriver to adjust the **PRESET ADJ B** potentiometer so that the rotator stops at exactly 450°.
14. Repeat steps 12 and 13 several times until the indicator responds reliably to presetting small angles when the rotator is near both ends of its range.
15. Set the **SELECT SWITCH** on the rear panel to the *left* (**OPERATION MODE**) position, and turn the **POWER** switch "OFF."
16. This completes the ground-based testing of the rotator and controller.

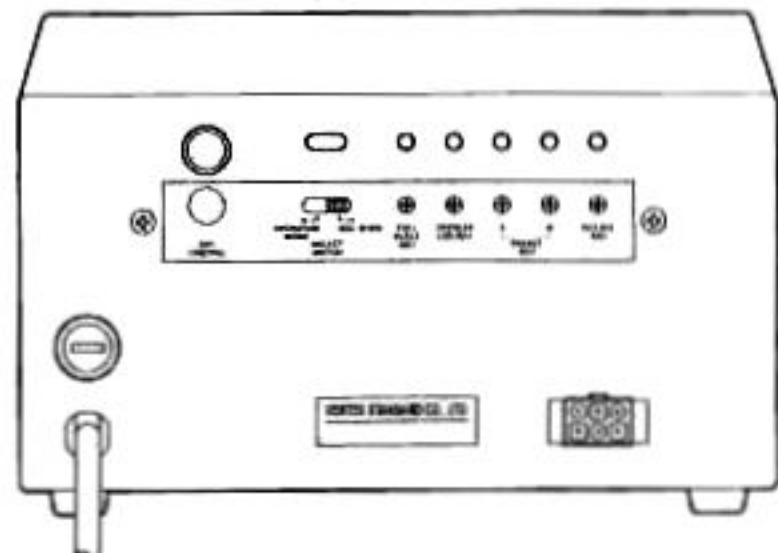

Controller Rear Panel

# Mounting the Rotator and Antenna

## INDOOR PERFORMANCE CHECK AND ALIGNMENT

### Installing the Dial Heading Sheet

A clear plastic round dial heading sheet is provided with the kit, which can be installed with north at any position you desire. This is particularly useful when you need to have south at the top of the dial (or east or west) instead of north. To install the heading scale:

- Turn on the **POWER** switch and press the seesaw switch to set the indicator needle to  $180^\circ$  (straight down), then turn off the **POWER** switch.
- Grasp the edge of the bezel around the bearing window, turn it  $10^\circ$  counter-clockwise, and pull it off.
- Note the position of the needle, then grasp it at its center, and pull it straight off.
- Determine which compass direction you desire to be upmost, and install the compass heading label sheet against the azimuth scale, so that the small teeth in the edges of the sheet lock around the edge.
- Replace the needle and bezel in the same direction as they were before (see diagram at the right).

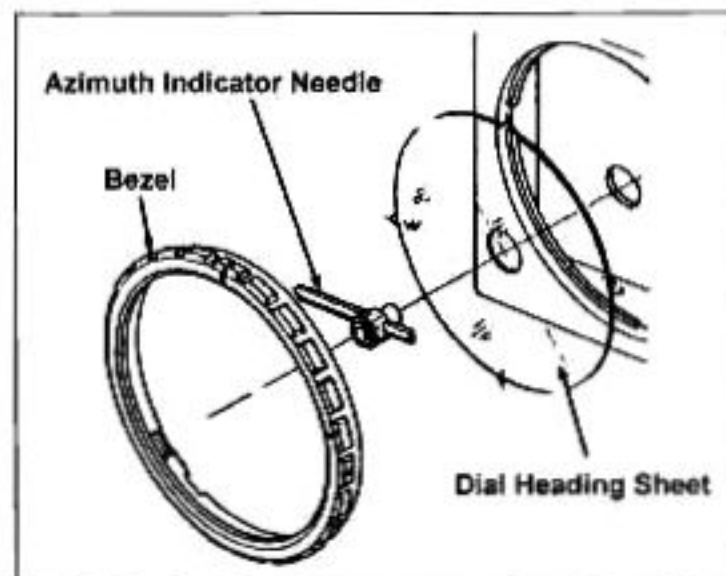

### PRESET Knob Calibration

Perform this procedure only if it is not possible to align the **PRESET** knob tracking using the **PRESET ADJ A** and **PRESET ADJ B** potentiometers on the rear panel, as described in steps 12 – 14 on the previous page.

- Pull off the **PRESET** control knob.
- Set the potentiometer shaft to the fully counter-clockwise position, then turn it  $30^\circ$  clockwise.
- Using care not to disturb the **PRESET** potentiometer, push the knob back on the shaft so that the knob stopper is aligned with the counter-clockwise edge of the slot in the panel behind the knob, as shown in the drawing to the right.
- Repeat steps 12 and 13 on the previous page for the **PRESET** Dial Tracking Alignment.

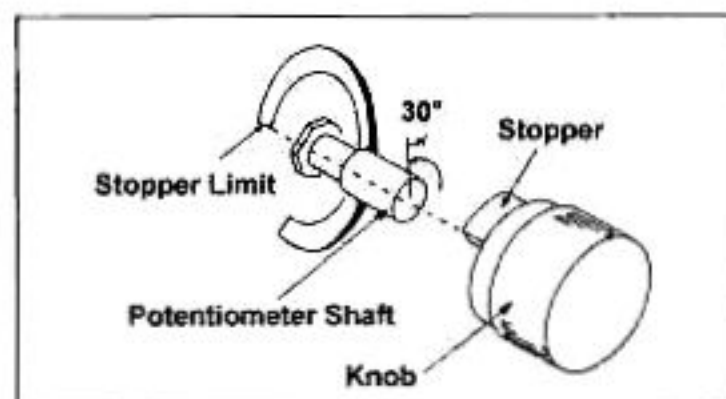

Do not forget to set the **SELECT SWITCH** on the rear panel to the *left* (**OPERATION MODE**) position after alignment.



# Mounting the Rotator and Antenna

## INSTALLATION OF THE G-800DXA/-1000DXA ROTATOR AND ANTENNA ON TOWER

**Important!!** Before mounting the mast to the rotator, a single hole must be drilled through the bottom of the mast to accommodate an anti-twist support bolt used in the base support clamp halves.

1. Drill a 9 mm diameter hole through both walls of the mast, centered 50 mm from the mast bottom (see Figure 1). Ensure the drill is maintained perpendicular and centered when making the holes, to ensure proper alignment of the holes in the mast with those in the base support clamp.
2. Attach the rotator to the tower's rotator mounting plate, using the supplied M8 x 16 bolts and spring washers. It is recommended that the tips of the bolts be lightly dipped in lubricating grease, to ease disassembly in the future (see Figure 2).
3. If a thrust bearing (such as the optional Yaesu model **GS-065**) is to be utilized, mount it on the top of the tower (see Figure 3) using the supplied hardware.
4. Partly tighten the mast clamp ① to the rotator housing using the supplied M8 x 25 bolts ②, spring washers and flat washers (see Figure 5).
5. Using a "gin pole" or other raising fixture, insert the antenna mast through the bearing from above, and set the mast in the rotator's mast clamps, then partly tighten the mast clamps using the supplied M8 x 70 bolts ③ and spring washer.

**Advice** One side of the clamp has ridges on either side of the bolt holes; the bolts should be inserted from this side, so the ridges hold the bolt head from turning.

6. Pass the supplied M8 x 95 screw ⑤ through the mast clamps and through the mast, then partly tighten it using the supplied square nut ⑥.
7. Partly tighten the thrust bearing's mast bolts, so as to center the mast in the thrust bearing. When you are satisfied that the mast is centered, tighten the thrust bearing's mast bolts to secure the mast in place.
8. Now tighten all the nuts of the mast clamp except for the square nut holding the M8 x 95 bolt through the mast clamps and mast. Leave the square nut only lightly secured at this time.

**Caution** Do not over-tighten the nuts on the mast clamps. They should be tightened until the spring washer becomes flat, then tightened further by  $\frac{1}{2}$  to one turn maximum.

9. Install the rotator control cable's round plug into the jack on the side of the rotator's base, and tighten the connector ring to secure the connector. Slide the rubber boot over the connector; while putting a slight amount of inward pressure on the rubber boot, use

electrical tape to secure the back end of the rubber boot to the cable. This slight inward pressure on the rubber boot will enhance the weatherproofing of the installation. Secure the control cable to the tower in several places, using electrical tape and/or UV-resistant cable ties.

10. Get a ground crew member to set the controller to 180° (South), which corresponds to 180° of rotation clockwise from the left "stop" point. During rotation, watch the M8 x 95 bolt to be sure it does not bind between the mast and the mast clamps. If binding is observed, stop rotation and make slight adjustments to the thrust bearing and/or mast clamps, so as to eliminate the binding. If the M8 x 95 bolt is not binding, you can go ahead and tighten the square nut securely.
11. Provide sufficient slack in the coaxial cable such that the antenna can rotate over its full 450° range without putting any tension on the coax (see Figure 8). Secure the coax to the tower, using electrical tape and/or UV-resistant cable ties.
12. Installation is now complete. If you have scratched through the melamine coating of the rotator during installation, you may wish to apply several coats of clear acrylic spray to help protect the bare metal from corrosion. After installation is complete, test the system by operating the rotator through the entire range of its rotation. It is helpful to do so with the help of an observer, so that rotation can be stopped if some obstruction, binding, or tension on the coaxial cable's turning loop should be encountered during the performance test.

### Installation Note

If using a roof tower with a long mast between the top of the tower and the antenna, the use of a "Guy Bearing" is highly recommended. The Yaesu **GS-050** and **GS-065** include guying "ears" which allow attachment of guy cables. As installing a guying system may cause the centerlines of the guy bearing and the rotator to become mis-aligned, be certain to check the roof tower attachment and guy cable alignment to ensure that the mast is straight.

# Mounting the Rotator and Antenna

## INSTALLATION OF THE G-800DXA/-1000DXA ROTATOR AND ANTENNA ON TOWER

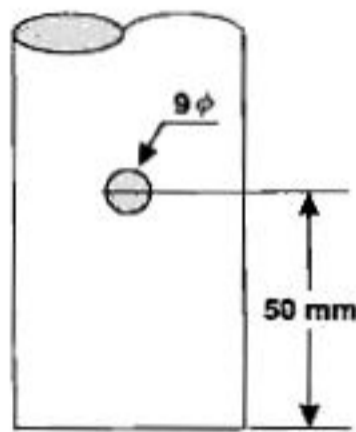

Figure 1

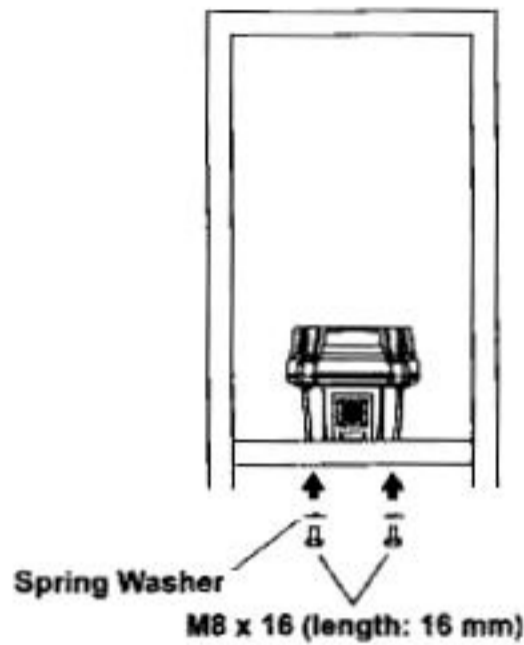

Figure 2

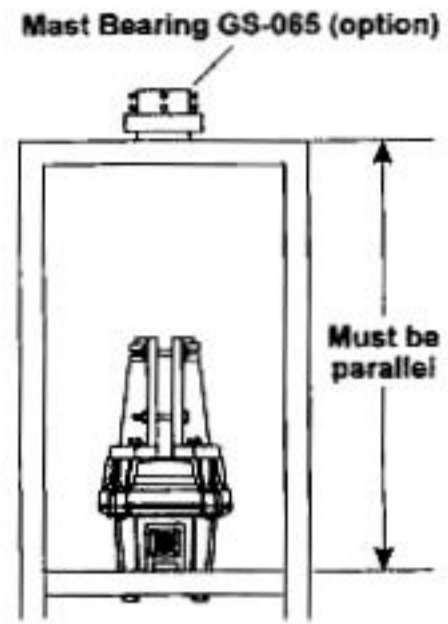

Figure 3

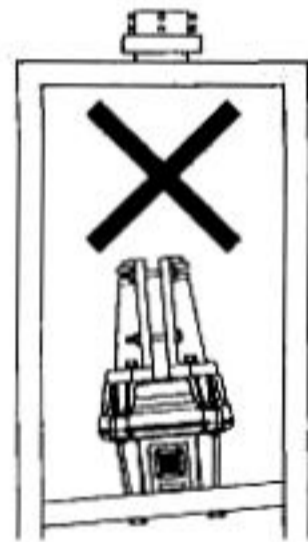

Figure 4

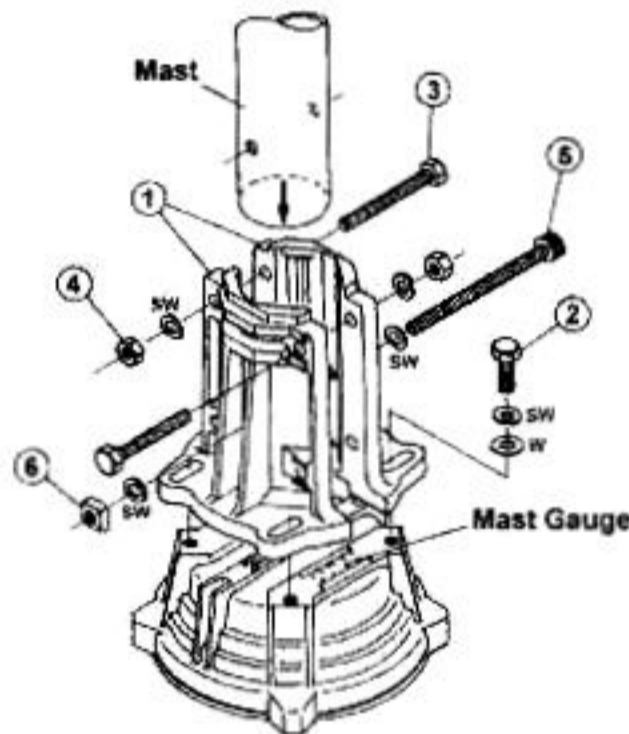

Figure 5

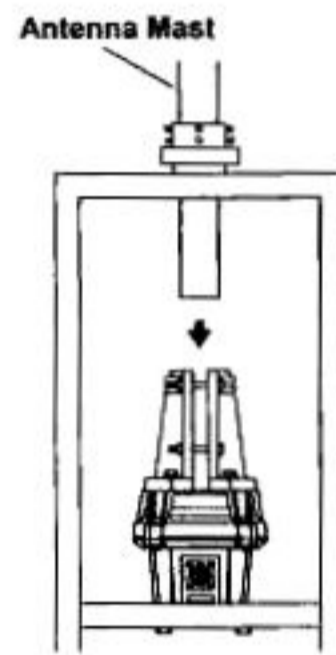

Figure 6

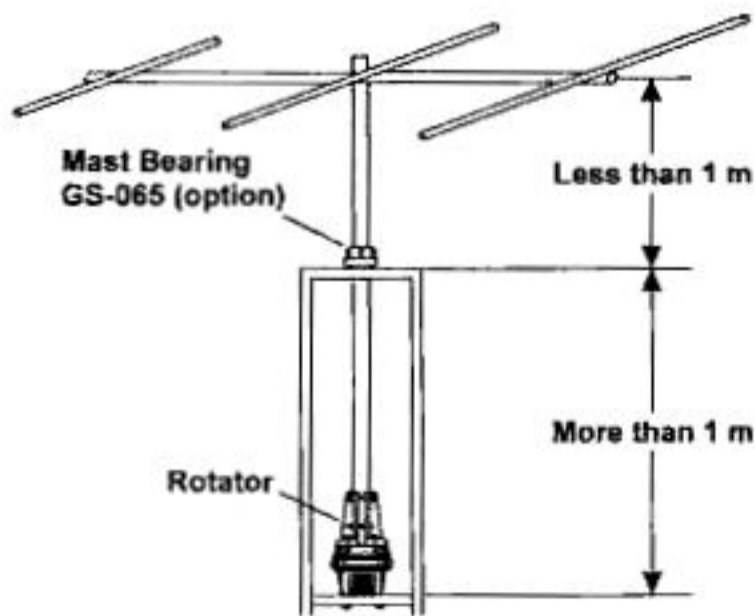

Figure 7

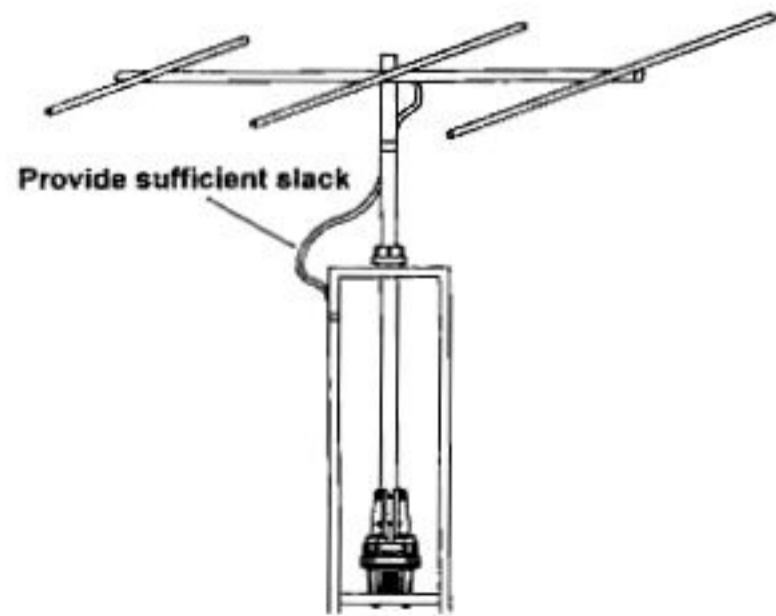

Figure 8



# Mounting the Rotator and Antenna

## INSTALLATION OF THE G-2800DXA ROTATOR AND ANTENNA ON TOWER

**Important!!** Before mounting the mast to the rotator, a single hole must be drilled through the bottom of the mast to accommodate an anti-twist support bolt used in the base support clamp halves.

1. Drill a 9 mm diameter hole through both walls of the mast, centered 82 mm from the mast bottom (see Figure 9). Ensure the drill is maintained perpendicular and centered when making the holes, to ensure proper alignment of the holes in the mast with those in the base support clamp.
2. Attach the rotator to the tower's rotator mounting plate, using the supplied M8 x 18 bolts and spring washers. It is recommended that the tips of the bolts be lightly dipped in lubricating grease, to ease disassembly in the future (see Figure 10).
3. If a thrust bearing (such as the optional Yaesu model **GS-065**) is to be utilized, mount it on the top of the tower (see Figure 11) using the supplied hardware.
4. Partly tighten the mast clamp ① to the rotator housing using the supplied M8 x 30 bolts ②, spring washers and flat washers (see Figure 13).
5. Using a "gin pole" or other raising fixture, insert the antenna mast through the bearing from above, and set the mast in the rotator's mast clamps, then partly tighten the mast clamps using the supplied M8 x 70 bolts ③, spring washers and flat washers.

**Advice** One side of the clamp has ridges on either side of the bolt holes; the bolts should be inserted from this side, so the ridges hold the bolt head from turning.

6. Pass the supplied M8 x 95 screw ④ through the mast clamps and through the mast, then partly tighten it using the supplied nut ⑤.
7. Partly tighten the thrust bearing's mast bolts, so as to center the mast in the thrust bearing. When you are satisfied that the mast is centered, tighten the thrust bearing's mast bolts to secure the mast in place.
8. Now tighten all the nuts of the mast clamp except for the nut holding the M8 x 95 bolt through the mast clamps and mast. Leave this nut only lightly secured at this time.

**Caution** Do not over-tighten the nuts on the mast clamps. They should be tightened until the spring washer becomes flat, then tightened further by ½ to one turn maximum.

9. Install the rotator control cable's round plug into the jack on the side of the rotator's base, and tighten the connector ring to secure the connector. Slide the rubber boot over the connector; while putting a slight amount of inward pressure on the rubber boot, use

electrical tape to secure the back end of the rubber boot to the cable. This slight inward pressure on the rubber boot will enhance the weatherproofing of the installation. Secure the control cable to the tower in several places, using electrical tape and/or UV-resistant cable ties.

10. Get a ground crew member to set the controller to 180° (South), which corresponds to 180° of rotation clockwise from the left "stop" point. During rotation, watch the M8 x 95 bolt to be sure it does not bind between the mast and the mast clamps. If binding is observed, stop rotation and make slight adjustments to the thrust bearing and/or mast clamps, so as to eliminate the binding. If the M8 x 95 bolt is not binding, you can go ahead and tighten the nut securely.
11. Provide sufficient slack in the coaxial cable such that the antenna can rotate over its full 450° range without putting any tension on the coax (see Figure 16). Secure the coax to the tower, using electrical tape and/or UV-resistant cable ties.
12. Installation is now complete. If you have scratched through the melamine coating of the rotator during installation, you may wish to apply several coats of clear acrylic spray to help protect the bare metal from corrosion. After installation is complete, test the system by operating the rotator through the entire range of its rotation. It is helpful to do so with the help of an observer, so that rotation can be stopped if some obstruction, binding, or tension on the coaxial cable's turning loop should be encountered during the performance test.

### Installation Note

If using a roof tower with a long mast between the top of the tower and the antenna, the use of a "Guy Bearing" is highly recommended. The Yaesu **GS-050** and **GS-065** include guying "ears" which allow attachment of guy cables. As installing a guying system may cause the centerlines of the guy bearing and the rotator to become mis-aligned, be certain to check the roof tower attachment and guy cable alignment to ensure that the mast is straight.



# Mounting the Rotator and Antenna

## INSTALLATION OF THE G-2800DXA ROTATOR AND ANTENNA ON TOWER

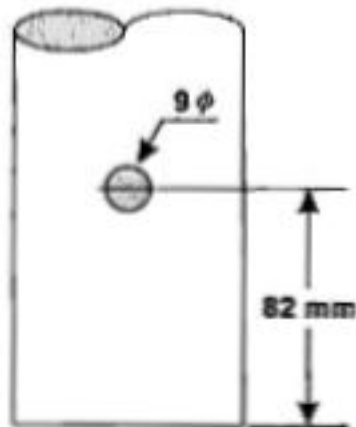

Figure 9

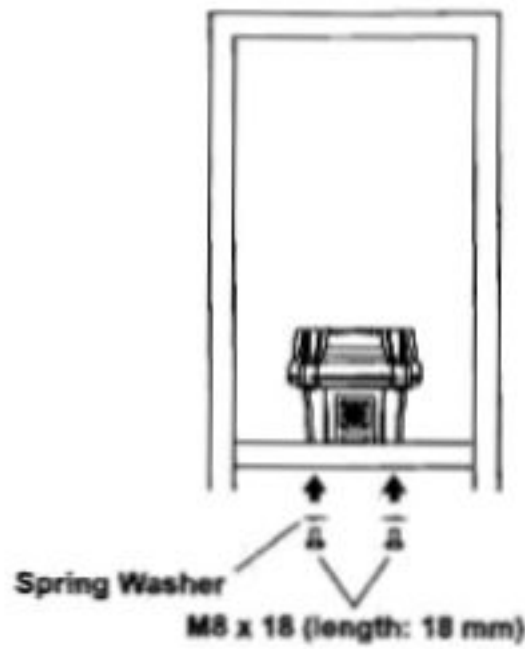

Figure 10

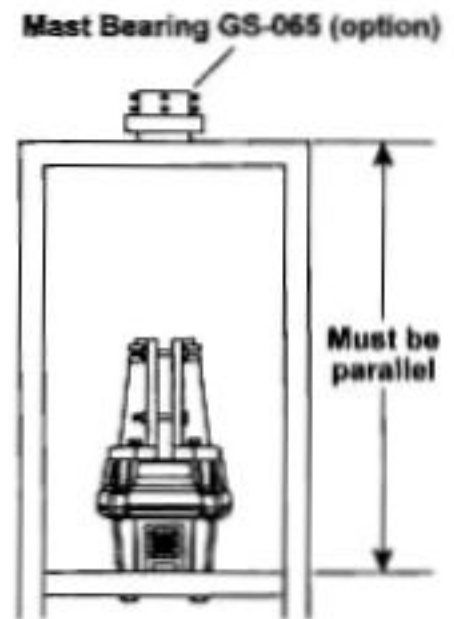

Figure 11

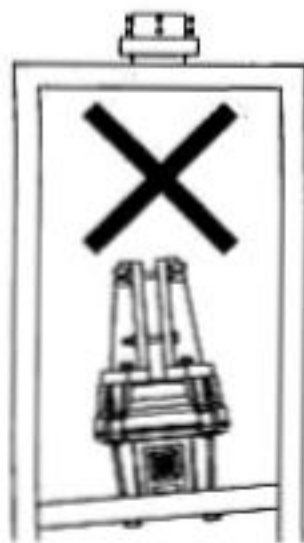

Figure 12

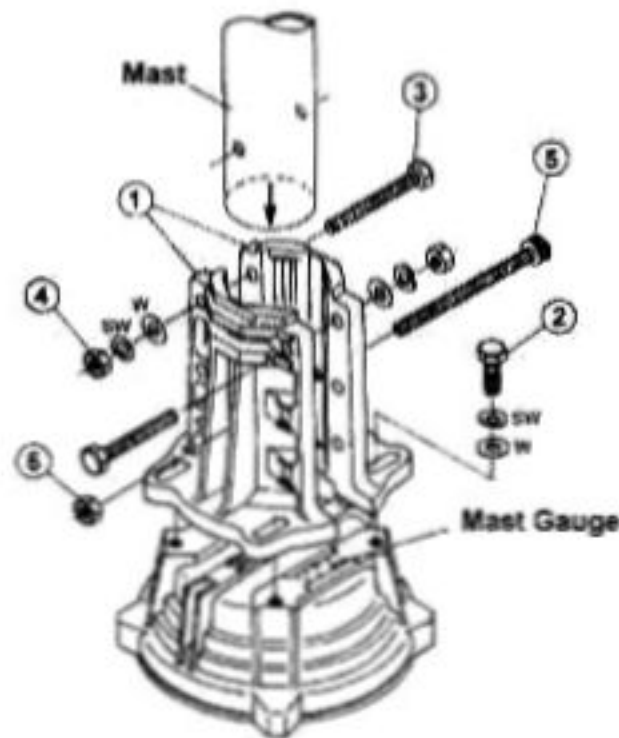

Figure 13

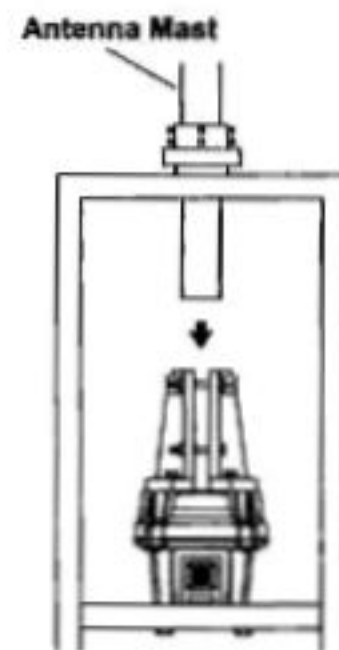

Figure 14

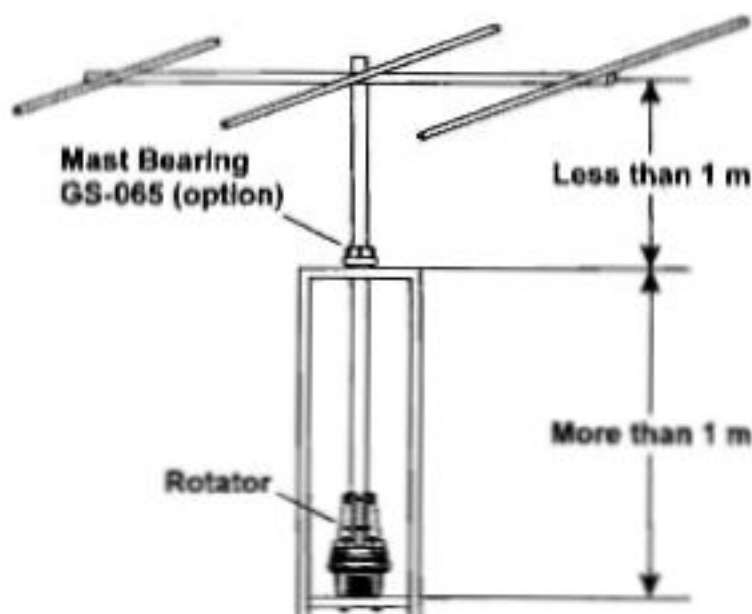

Figure 15

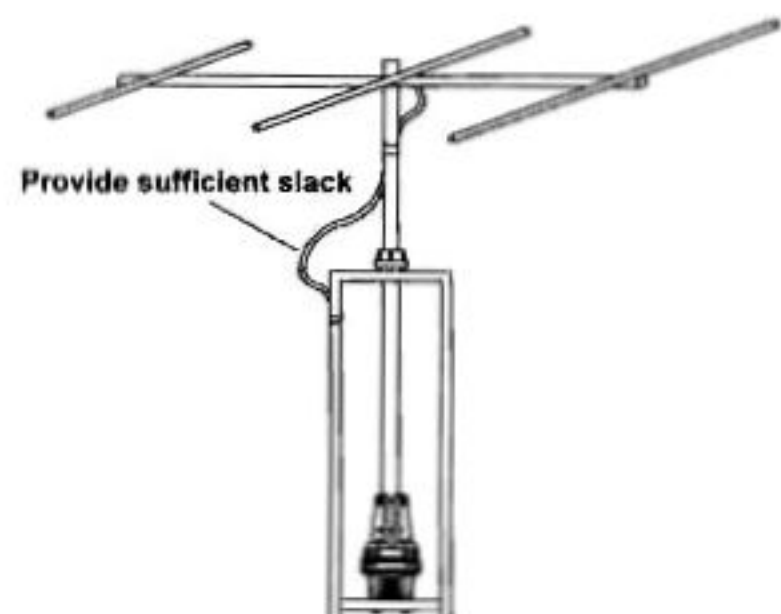
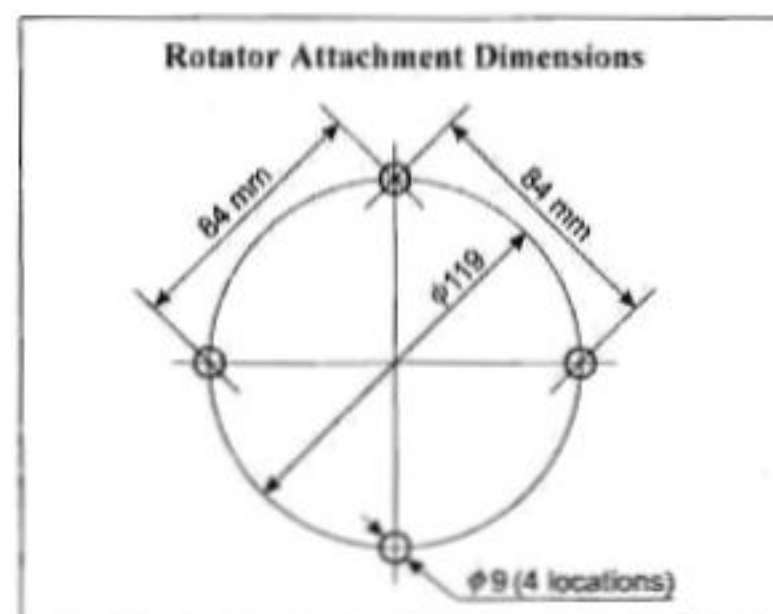

Figure 16

# Specifications

MODEL	G-800DXA	G-1000DXA	G-2800DXA
Power Supply Voltage	117/220 VAC, 50/60 Hz	117/220 VAC, 50/60 Hz	117/220 VAC, 50/60 Hz
Power Supply Current Consumption	1 A (117 VAC) 0.5 A (220 VAC)	1 A (117 VAC) 0.5 A (220 VAC)	1.5 A (117 VAC) 0.7 A (220 VAC)
Rotor Voltage	11 ~ 24 VDC	11 ~ 24 VDC	11 ~ 24 VDC
360° Rotation Time (Non Loaded)	100 ± 10 sec to 40 ± 5 sec (Variable)	100 ± 10 sec to 40 ± 5 sec (Variable)	120 ± 10 sec to 50 ± 5 sec (Variable)
Rotation Range	450° ± 3°	450° ± 3°	450° ± 3°
Rotation Torque	600 to 1,100 kgf-cm (43 to 80 ft-lbs)	600 to 1,100 kgf-cm (43 to 80 ft-lbs)	800 to 2,500 kgf-cm (57 to 180 ft-lbs)
Braking Torque	4,000 kgf-cm (289 ft-lbs)	6,000 kgf-cm (434 ft-lbs)	25,000 kgf-cm (1800 ft-lbs)
Maximum Vertical Load	200 kg (441 lbs) or less (continuous) 800 kg (1764 lbs) (momentary)	200 kg (441 lbs) or less (continuous) 800 kg (1764 lbs) (momentary)	300 kg (661 lbs) or less (continuous) 1,200 kg (2646 lbs) (momentary)
Mast Outside Diameter	φ38 to φ63	φ38 to φ63	φ48 to φ63
Braking Type	Mechanical and Electrical stoppers	Mechanical and Electrical stoppers	Mechanical and Electrical stoppers
Antenna K Coefficient	180 or less	230 or less	950 or less
Wind Loading Area	0.75 m <sup>2</sup> x 0.6 m or less (Pole Type) 2 m <sup>2</sup> or less (Tower Type)	0.75 m <sup>2</sup> x 0.6 m or less (Pole Type) 2.2 m <sup>2</sup> or less (Tower Type)	1 m <sup>2</sup> x 0.8 m or less (Pole Type) 3 m <sup>2</sup> or less (Tower Type)
Maximum Continuous Duty	3 minutes	3 minutes	3 minutes
Operating Temperature Range	0 °C to +40 °C (Controller) -20 °C to +40 °C (Rotator)	0 °C to +40 °C (Controller) -20 °C to +40 °C (Rotator)	0 °C to +40 °C (Controller) -20 °C to +40 °C (Rotator)
Rotator Dimensions	φ186 x 300 mm (φ7.3 x 11.8 inch)	φ186 x 300 mm (φ7.3 x 11.8 inch)	φ200 x 345 mm (φ7.8 x 13.6 inch)
Rotator Weight	Approx. 3.6 kg (7.9 lbs)	Approx. 3.6 kg (7.9 lbs)	Approx. 6.5 kg (14.3 lbs)
Controller Dimensions (W)x(H)x(D)	200 x 130 x 193 mm (7.8 x 5.1 x 7.6 inch)	200 x 130 x 193 mm (7.8 x 5.1 x 7.6 inch)	200 x 130 x 193 mm (7.8 x 5.1 x 7.6 inch)
Controller Weight	Approx. 2.8 kg (6.2 lbs)	Approx. 2.8 kg (6.2 lbs)	Approx. 3.8 kg (8.4 lbs)



# Accessories & Options

## UNPACKING & INSPECTION

When unpacking the rotator make sure you find the following items:

<b>G-800DXA/-1000DXA</b>	<b>QUANTITY</b>	<b>G-2800DXA</b>	<b>QUANTITY</b>
Controller Unit	1	Controller Unit	1
Rotor Unit	1	Rotor Unit	1
Mast Clamp	1 pair	Mast Clamp	1 pair
7-pin Round Plug (with Rubber Boot)	1 set	Control Cable (40 m, 6 core cable)	1
6-pin Rectangular Plug	1 set	M8 x 95 mm Socket Head Cap Screw	1
M8 x 95 mm Socket Head Cap Screw	1	M8 x 18 mm Hex Bolts	4
M8 x 16 mm Hex Bolts	4	M8 x 30 mm Hex Bolts	4
M8 x 25 mm Hex Bolts	4	M8 x 70 mm Hex Bolts	6
M8 x 70 mm Hex Bolts	4	Split Washers	14
Split Washers	14	Flat Washers	10
Flat Washers	4	M8 Nuts	7
M8 Nuts	4	Plastic Dial Heading Sheet	1
Square Nut	1		
Plastic Dial Heading Sheet	1		

*If any of these items are missing or damaged, save the packing material and notify the shipping company (or the shop where you bought it).*

## OPTIONAL ACCESSORIES

<b>GC-038</b>	Mast Clamp (for the <b>G-800DXA</b> and <b>G-1000DXA</b> )
<b>GC-048</b>	Mast Clamp (for the <b>G-2800DXA</b> )
<b>GS-050</b>	Universal Thrust Bearing (for 50 mm mast)
<b>GS-065</b>	Universal Thrust Bearing (for 65 mm mast)
<b>GS-232A</b>	Computer Control Unit (RS-232C Serial)
<b>C-25MWP</b>	Control Cable (25 m)
<b>C-40MWP</b>	Control Cable (40 m)
<b>GA-2500</b>	Absorber Joint (for the <b>G-800DXA</b> and <b>G-1000DXA</b> )
<b>GA-3000</b>	Absorber Joint (for the <b>G-2800DXA</b> )



# G-800DXA/-1000DXA Connection Diagram

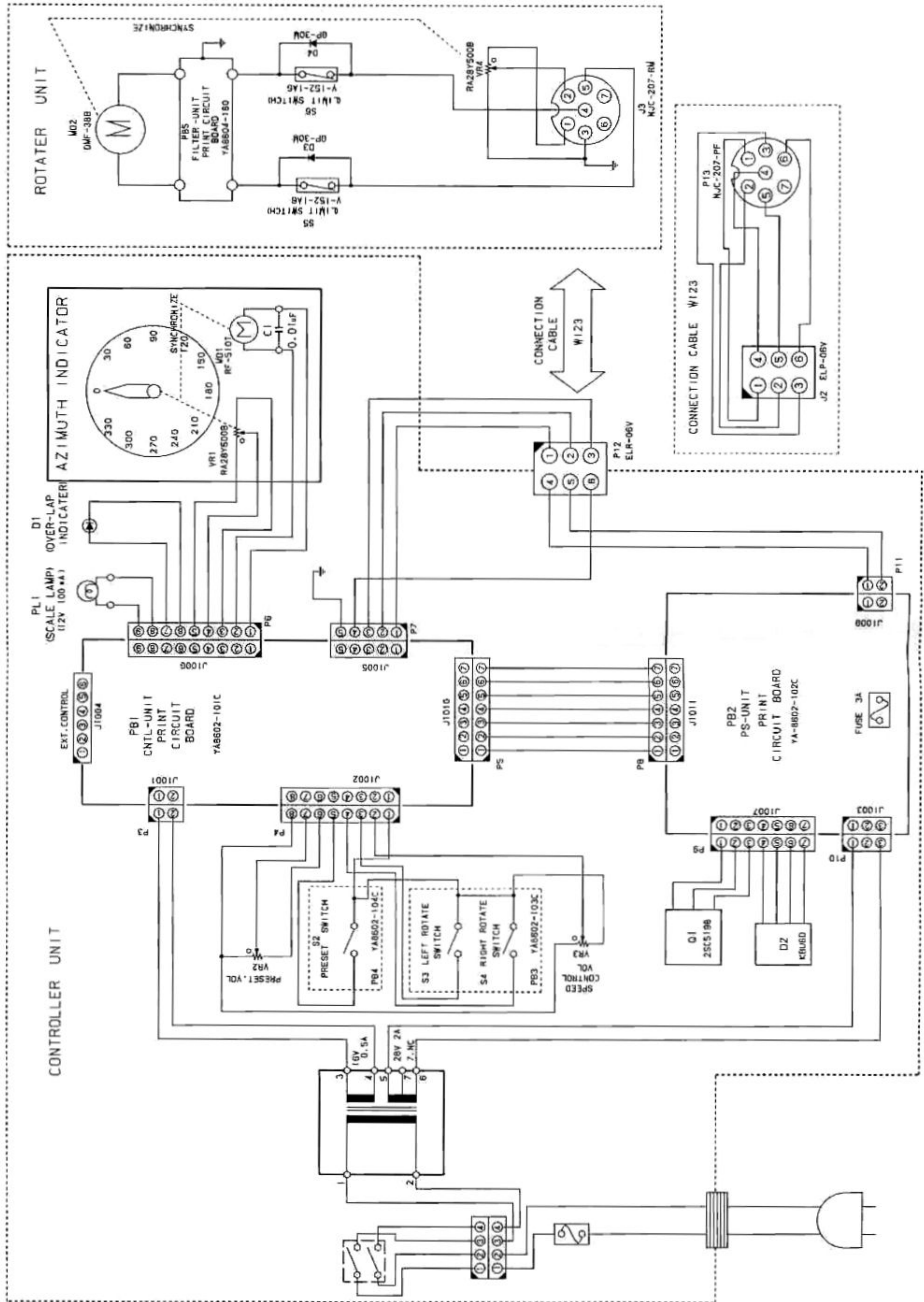





# G-2800DXA Connection Diagram

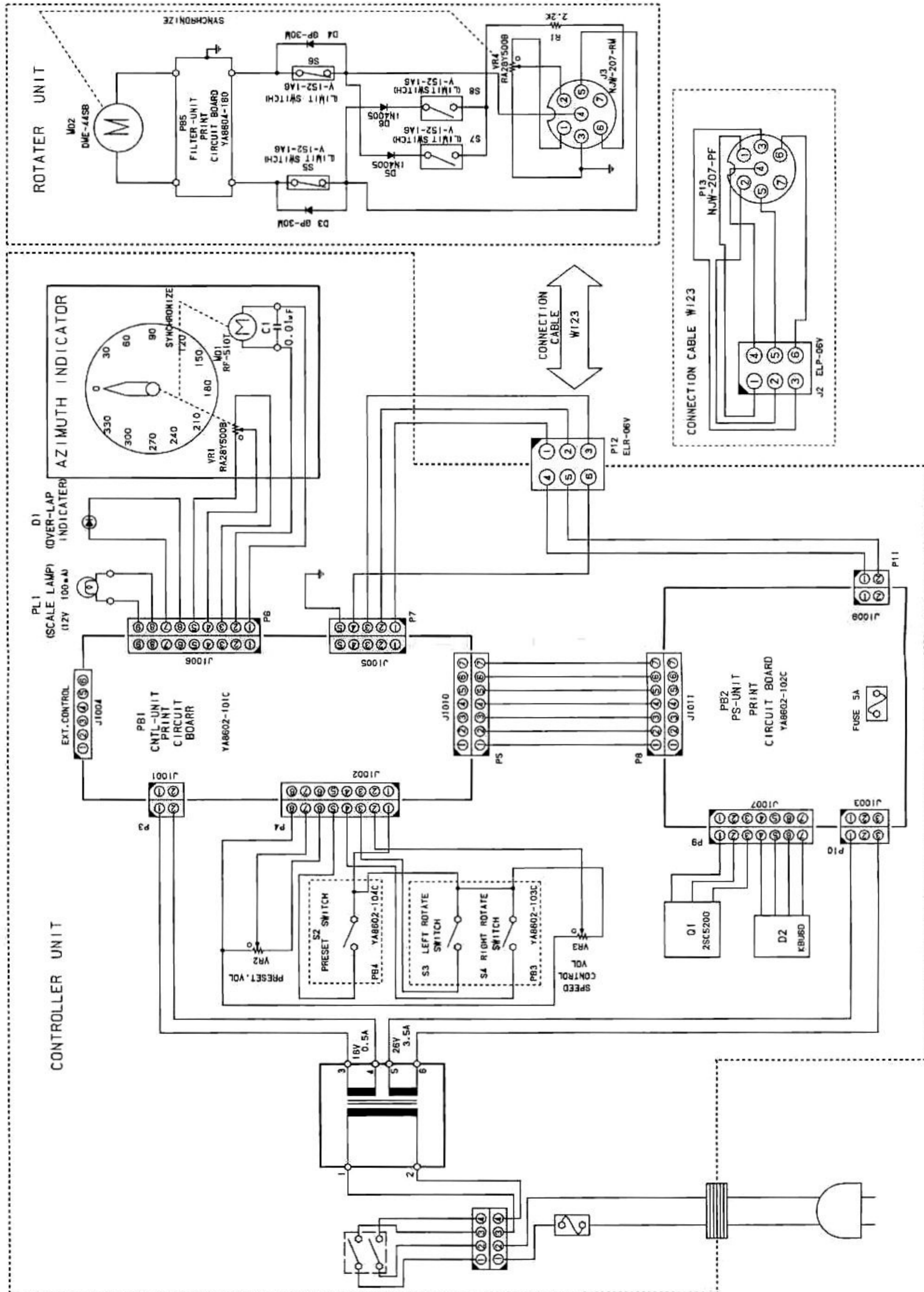



# G-2800DXA Circuit Diagram

