

LAFAYETTE KT-340

(Stock No. 99-2521WX)



COMMUNICATIONS RECEIVER

assembly
manual

TECHNICAL SPECIFICATIONS

FREQUENCY RANGES.....	BAND A 550 - 1600 Kc BAND B 1.6 - 4.8 Mc BAND C 4.8 - 14.5 Mc BAND D 10.3 - 30 Mc
BANDSPREAD.....	Calibrated Electrical Bandsread 80 and 40 meters, 5 Kc per division 20 and 15 meters, 20 Kc per division 10 meters, 50 Kc per division
ANTENNA INPUT	50 - 400 ohms impedance
AUDIO POWER OUTPUT.....	1.5 watts
SENSITIVITY.....	1 μ v for 10 db S/N Ratio
SELECTIVITY.....	\pm 10 Kc at -60 db (\pm 2 Kc at -6 db) without Q-Multiplier \pm 0.8 Kc at -6 db with Q-Multiplier
IF.....	455 Kc
SPEAKER OUTPUT.....	4 or 8 ohms
HEADPHONE OUTPUT.....	Low Impedance
POWER CONSUMPTION	50 watts at 117 volts AC, 60 cps.
TUBE COMPLEMENT	V1 - 6BA6 RF Amplifier V2 - 6BE6 Mixer V3 - 6BE6 HF Oscillator V4 - 6AV6 Q-Multiplier-BFO V5 - 6BA6 1st IF Amplifier V6 - 6BA6 2nd IF Amplifier V7 - 6AV6 Detector, 1st AF Amplifier, ANL, AVC V8 - 6AQ5 Audio Output V9 - 5Y3 Rectifier
DIMENSIONS.....	7" H. x 15" W. x 10" D.
WEIGHT	21 lbs.

UNPACKING INSTRUCTIONS

After the kit has been removed from the packing container, place the kit on your work table. Remove the four screws that hold the cabinet cover in place and lift up to remove cabinet cover. Underneath will be found the unmounted parts necessary to wire the KT-340. Check these parts for proper values and quantity against the Unmounted Parts List located in this manual. (To avoid confusion, check off each item as it is found to be correct.) Some components may have slightly different values than those in the list and, in such cases, is permissible.

Unmounted resistors and capacitors will be found on cards, marked for easy identification. For even greater ease in identification, each component is itself marked with its value.

NOTE: In the case of resistors, do not confuse the Greek symbol omega (Ω) for a zero. Omega, as it is used in electronics, means "ohm", the unit of electrical resistance.

DAMAGE IN SHIPMENT

If your kit was damaged in shipment, please notify us immediately, describing the damage, and get in touch with the carrier so that you can make a claim. We will cooperate fully in such cases, but please note that only you can recover from the carrier.

REPLACEMENT WARRANTY

In accordance with the terms of the industry-wide Electronics Industry Association (EIA) warranty, Lafayette Radio will replace, free of charge, any defective parts returned to us within 90 days from the date of purchase of this kit by the original purchaser. Such replacement will be made only in cases where parts were defective at the time of sale or became defective in normal operation during the 90-day warranty period. Parts damaged during kit construction or through customer's wiring error are not subject to replacement.

UNMOUNTED PARTS LIST

CIRCUIT DESIGNATION	DESCRIPTION	QUANTITY
TUBES *		
V1, V5, V6	6BA6	3
V2, V3	6BE6	2
V4, V7	6AV6	2
V8	6AQ5	1
V9	5Y3	1
PL	#40 light bulb	2
*On some units, the tubes are already installed in their sockets.		
CAPACITORS		
C1, C5	250 μ fd, mica	2
C2, C4, C6, C7, C13, C14, C15, C16, C17, C18, C19	0.01 μ fd, disc	11
C3	0.05 μ fd, tubular	1
C8, C20, C22	100 μ fd, mica	3
C9	0.005 μ fd, disc	1
C10	0.001 μ fd, mica	1
C11	0.003 μ fd, mica	1
C12	500 μ fd, mica	1
C21, C23, C28	0.01 μ fd, tubular	3
C24	10 μ fd, electrolytic	1
C25	0.005 μ fd, tubular	1

CIRCUIT DESIGNATION	DESCRIPTION	QUANTITY
RESISTORS		
R1	47 ohm, 1/4 watt	1
R2, R4	1 M (meg) ohm, 1/4 watt	2
R3, R5, R13	330 ohm, 1/2 watt	3
R6	22 K (kil) ohm, 1/4 watt	1
R7, R11, R14, R16	1 K ohm, 1/2 watt	4
R8	22 K ohm, 1/2 watt	1
R9, R18	2.2 M ohm, 1/4 watt	2
R10	3.3 K ohm, 1/2 watt	1
R12	100 K ohm, 1/4 watt	1
R15	2.2 K ohm, 1/4 watt	1
R17	47K ohm, 1/4 watt	1
R19	4.7 M ohm, 1/4 watt	1
R20	220 K ohm, 1/2 watt	1
R21	470 K ohm, 1/4 watt	1
R22	470 ohm, 1 watt	1
R23	2 K ohm, 10 watts	1
	2.2 K ohm, 10 watts*	1

* May have been supplied, but is not required for this kit.

WIRES, CABLES AND MISCELLANEOUS

	Length (Approx.)
Black sleeving	13"
Single conductor shielded cable	5'
Double conductor shielded cable	3' 6"
Red lead	11' 8"
Blue lead	8' 6"
Yellow lead (light)	3' 5"
Yellow lead (heavy)	6' 6"
White lead	11' 6"
Black lead (light)	6' 9"
Black lead (heavy)	8' 6"
Bare wire (light)	5'
Bare wire (heavy)	1'
Braided flat wire	3' 5"
Metal stripping	7"
Tube shield	1
Earphone plug	1
Solder	5'

MOUNTED PARTS LIST

CAPACITORS

C26 and C27	40-40 μ fd, 300 volt electrolytic	1
C29A	Main Tuning Capacitor	1
C29B	Band Spread Tuning Capacitor	1
C30	Antenna Trimmer	1
C31	50 μ fd, variable capacitor (BFO)	1

RESISTORS

R24	10 K ohm, IF Gain Control	1
R25	500 K ohm, Audio Gain Control	1
R26	10 K ohm, Selectivity Control	1
R27	30 ohm, 1/4 watt	1
R28	500 ohm, S-meter Zero Adjust	1

SWITCHES

S1	FUNCTION Switch	1
S2	BAND SEL Switch	1
S3	SPDT Input Voltage Selector	1
S4	CW-SSB Switch (On R26)	1
S5	SPST ANL OFF - ON Switch	1
S6	SPST MVC - AVC Switch	1

TOOLS YOU WILL NEED

The following tools will be required to properly wire this kit.

1. A small soldering iron or gun (about 25 to 50 watts).
2. A pair of long-nose pliers.
3. A pair of diagonal (side-cutting) pliers.
4. A small Phillips-head screwdriver.
5. A 7-inch screwdriver with a 1/4" blade.
6. A small adjustable, open-end wrench.

Also valuable, but not absolutely essential, is a multimeter such as the Lafayette TE-10, TK-10, or RW-60.

NOTES ON WIRING

INTRODUCTORY

The wiring instructions have been carefully planned and arranged in the most logical and practical sequence possible. Skilled engineers and technical writers have prepared these instructions while actually assembling samples of this kit. We are certain you have been provided with the best and fastest method of assembling your kit.

PICTORIALS

Wiring instructions have been divided into three major groups entitled "Wiring the Q-MULT-BFO ASSEMBLY", "Wiring in the Leads", and "Wiring in the Components". For each of these major groups there is an accompanying PICTORIAL which depicts how the wired chassis should appear upon completion.

Points at which connections are to be made are designated by letter-number symbols on the PICTORIALS. For example, the symbol "E12" refers to the twelfth-numbered ground lug connection; "H7" refers to the seventh-numbered chassis hole; and "L4, lug 3" refers to the third lug on the fourth-numbered terminal strip.

STEP-BY-STEP INSTRUCTIONS

Each of the major wiring groups have been broken down into as many steps as will be required to complete the wiring. Each step should be read entirely before proceeding to accomplish what the step asks. After each step has been completed, place a check in the space "()" provided. Doing this will avoid omitting any steps. To be doubly sure, color in (on the PICTORIAL) each wire or component after it has been inserted. Also included are instructions for when and when not to solder. They are as follows:

- (NS) - means that the mechanical connection made at this point is NOT soldered.
- (S-2) - this indicates that the mechanical connection, at this point, IS to be soldered and the number indicates how many leads going to this point there should be.

NOTES ON SOLDERING

The importance of good soldering technique in the construction of kits cannot be over-emphasized. Good solder joints are essential if you are to realize the quality and stability of performance that has been engineered into this unit. If you are inexperienced in soldering, we suggest that you spend a little time practicing with pieces of scrap wire and an old tube socket or terminal strip before attempting to do any soldering on your kit. The purpose of soldering an electrical connection is to provide a permanent electrical bond between the wires and terminals to be joined. This prevents the formation of corrosion which insulates or produces unwanted resistance between the joined parts. It is not at all difficult to make a good solder connection that will provide the required electrical bond if you will simply observe a few basic rules for good soldering.

1. Use only good quality, rosin-core solder made specifically for radio and television use; a good composition is 60 per cent tin and 40 per cent lead (usually indicated as 60/40). Acid core solder or paste flux must NOT, under any circumstances, be used, as the corrosive effects of these materials will cause much damage to the circuit components.

CAUTION

THE USE OF ACID CORE SOLDER OR PASTE FLUX ON THIS KIT OR ANY PORTION THEREOF
AUTOMATICALLY VOIDS OUR WARRANTY COVERAGE.

2. Use a good soldering iron, 25-50 watts. The tip of the iron must be kept clean and well tinned, in accordance with the instructions of the soldering iron manufacturer, to obtain consistently good connections. The tip should present a bright appearance and be free of excess solder. An old rag or a pad of steel wool may be used to wipe the hot tip clean occasionally during use.
3. Be sure leads and terminals to be joined are clean and free of wax or corrosion before soldering. The solder will not adhere properly to the joint if the leads and terminals are dirty or corroded. This will usually result in a "cold" or high resistance connection.
4. A good mechanical connection should always be made before soldering, by crimping the leads on the terminals with your pliers. Do not rely on solder alone for physical strength. Stranded hook-up wire should always be tinned with solder before being connected.
5. To solder properly, apply the iron to the joint for a few seconds; then apply the solder and hold the iron on the connection until the solder flows freely. The solder must flow completely over the connection. Simply melting drops of solder onto the connection will not produce the desired results, but will result in a "cold" solder connection. This presents a dull and pitted or "grainy" appearance. A good connection will have a smooth and shiny appearance. Remember, the joint itself must be heated sufficiently to melt solder before the solder will flow smoothly and freely in and around the connection; however, you must be careful not to apply heat too long. Excessive heat from the iron may damage components and insulation on wires connected to the joint. When soldering a joint having a small component connected to it (a 1/2 watt resistor, for example) the component may be protected from excessive heat from the iron by grasping the lead between the joint and the component with long-nose pliers. The pliers will then conduct most of the heat away from the component, preventing overheating. Do not use too much solder when making a connection. Use only enough to completely cover all leads and to fill lug or terminal holes. Excessive use of solder may result in the formation of solder "bridges" or shorts between adjacent terminals or nearby wiring, particularly on tube sockets and switch terminals. Also, solder may flow into the switch contacts, destroying switch action.

WIRING THE Q-MULT-BFO ASSEMBLY

(Refer to Pictorial 1)

PRE-WIRING PROCEDURE

To identify and locate the Q-MULT-BFO Assembly refer to Figure A of PICTORIAL NO. 1.

1. () Remove the Q-MULT-BFO Assembly from the main chassis by removing the four Phillips-head screws. Place the main chassis temporarily aside.
2. () Push through with a screwdriver, the chassis lug, E13, to an angle of approximately 45 degrees.
3. () **IMPORTANT:** Before proceeding, examine the base of transformer T6 and note whether the four solder terminals are oriented with the terminals P, B, E & G in the position shown in Pictorial 1. If they are not, loosen the two transformer securing nuts and orient the transformer so that the terminals are positioned as shown in the Pictorial.

WIRING

NOTES: (a) The term "lead", as defined in this manual, means wire.

- (b) All leads and components should have approximately the same placement shown in the PICTORIAL.
- (c) Instructional steps for the insertion of components will be laid out as follows: first, the component to be used is mentioned; secondly, how the component's leads are to be cut (see Note "d"); and then to where the component will be connected.
- (d) Component lead lengths have been measured from the point at which the lead leaves the body of the component.

1. () Cut 2" of BLACK lead. Connect it from V4, center post (NS) to E13 (NS).
2. () Cut 2-1/2" of RED lead. Connect it from T6, lug P (NS) to V4, lug 7 (S-1).
3. () Cut 6-7/8" of RED lead. Connect it to T6 lug P (NS). The other end of this lead will be connected later.
4. () Cut 9-3/4" of BLUE lead. Connect it to V4 lug 2 (S-1). The other end of this lead will be connected later.
5. () Cut 9-3/8" of heavy YELLOW lead. Connect it to V4 lug 3 (S-1). The other end of this lead will be connected later.
6. () Cut 9-3/8" of heavy BLACK lead. Connect it to V4 lug 4 (S-1). The other end of this lead will be connected later.

NOTE: Twist the YELLOW and BLACK leads of steps 5 and 6 respectively together as shown on the PICTORIAL.

7. () Cut 9-3/4" of BLACK, SINGLE-CONDUCTOR, SHIELDED cable (Refer to Fig. 1). Prepare both ends as follows: Remove 1 inch of outer insulation. Push the shield back exposing the inner conductor. Twist the strands of the shield together and tin. Remove 1/4" of insulation from the inner conductor and tin. The cable should appear as in the figure. Proceed to the next step.
8. () Connect one end of the cable's inner conductor to T6 lug G (NS). From the same end connect the shield lead to E13 (NS). The other ends of this cable will be connected later.
9. () R9, 2.2M Ω , 1/4W. Cut one lead to 1/2" and the other to 3/4". Connect the 1/2" lead to V4 lug 1 (NS) and the 3/4" lead to E13 (NS).
10. () C12, 500 μ fd, mica. Cut both leads to 1/2". Connect it from V4 lug 1 (S-2) to T6 lug G (NS).
11. () C10, 0.001 μ fd, mica. Cut both leads to 1". Connect it from T6 lug P (S-3) to V4, center post; bend lugs 5 and 6 (of V4) to the center post and solder (S-4).
12. () C11, 0.003 μ fd, mica. Cut both leads to 1". Connect it from E13 (S-4) to T6 lug G (S-3).

13. () Recheck wiring on Q-MULT-BFO Assembly. (Place the main chassis back on your work table.) Twist the disconnected leads (there should be five) together so that they pass through hole H7 on the main chassis. Pull Q-MULT-BFO Assembly toward the main chassis (with tube socket toward the front) and fasten with 4 Phillips-head screws. Turn the chassis over. Untwist the leads coming through hole H7 and re-twist together only the YELLOW and BLACK leads. (See Pictorial 2 for location of hole H7.)

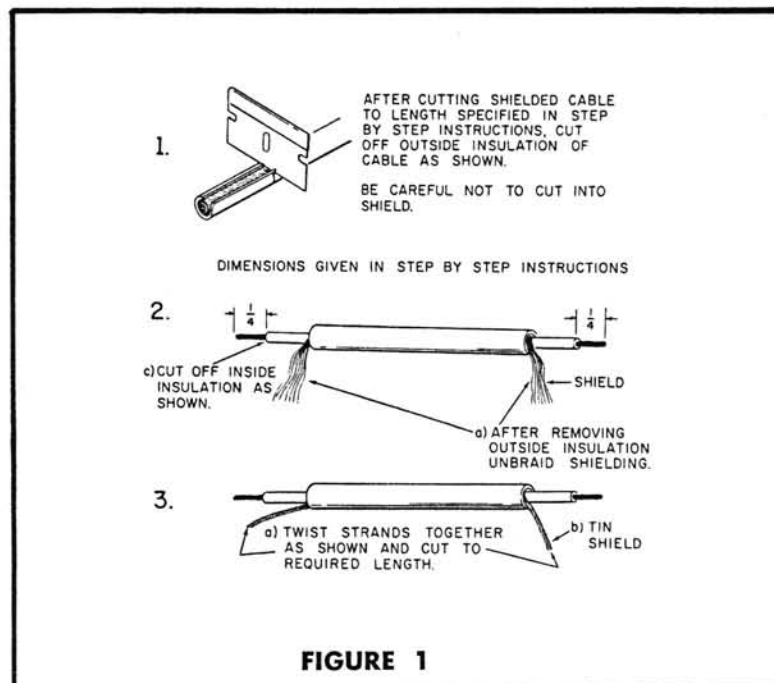
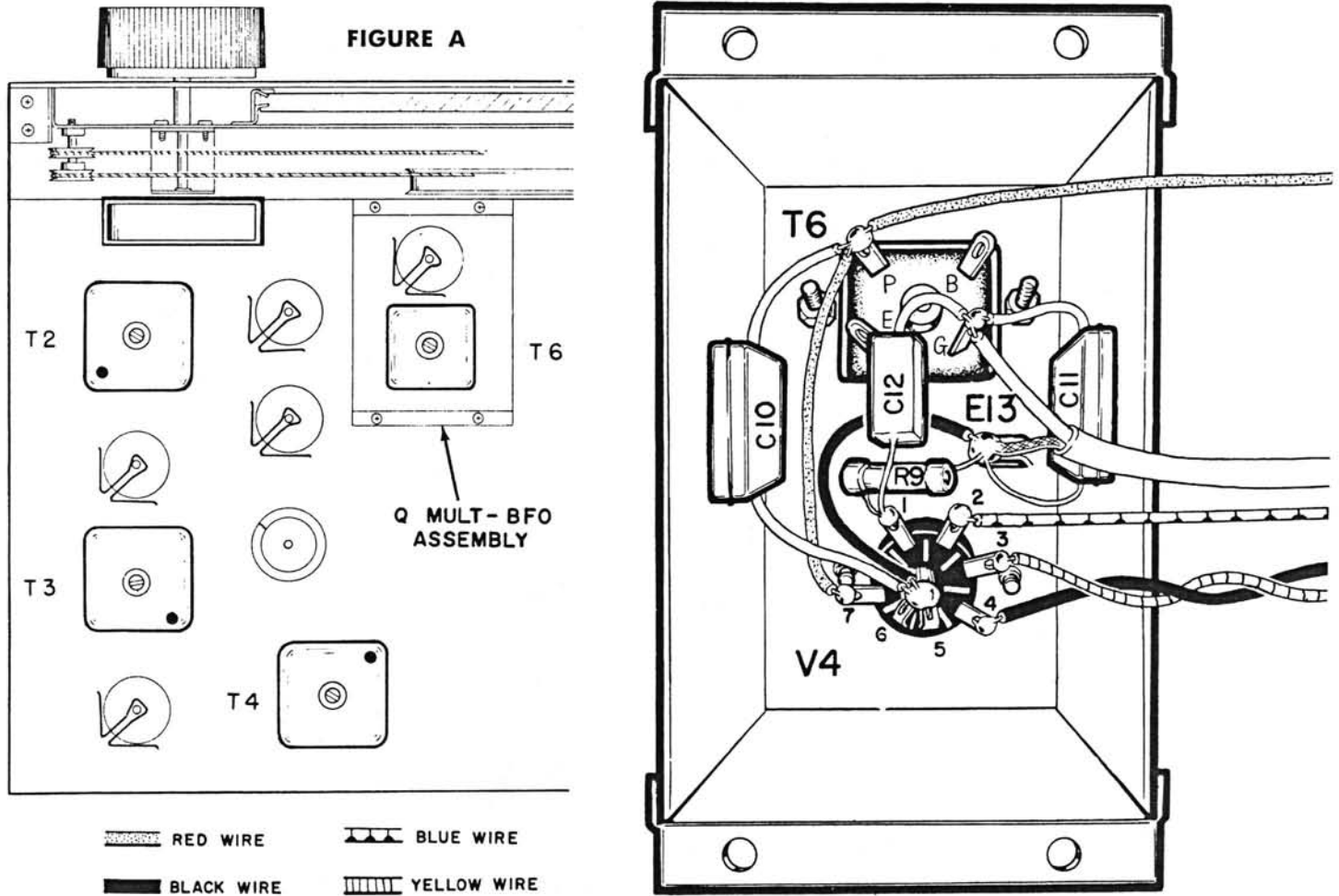

WIRING IN THE LEADS

(Refer to Pictorial 2)

PRE-WIRING PROCEDURE

- () Push through, with a screwdriver, the 12 chassis (ground) lugs to an angle of approximately 45 degrees. These lugs are located at the following points on the PICTORIAL: E1 through E12. (E1, E2, and E4 have to be pried up from the underside of the main chassis.)

WIRING

NOTES: (a) The term "lead", as defined in this manual, means wire.

(b) All leads should have approximately the same placement shown in the PICTORIAL.

- () Cut 3-3/8" of BARE lead. Connect it from J2 lug 1 (S-1) to E3 (NS).
- () Cut 3" of BARE lead. Connect it from C26-27 lug 3 (S-1) to E3 (NS).
- () Cut 2" of BARE lead. Connect it from E4 (S-1) to T1 lug 8 (NS).
- () Cut 3" of BARE lead. Connect it from T1 lug 8 (S-2) to T1 lug 6 (S-1).
- () Cut 2-1/2" of BARE lead. Connect it from R26 lug 2 (S-1) to E1 (NS).
- () Cut 2-3/8" of BARE lead. Connect it from R24 lug 2 (S-1) to E2 (NS).
- () Cut 1-1/2" of BARE lead. Connect it from V3 lug 5 (NS) through V3 lug 6 (S-1) to V3 lug 7 (S-1). Trim off excess.
- () Push V5 lug 2 to V5's center post. Cut 1-1/2" of BARE lead. Connect from E5 (NS) to V5 center post (S-2). Be sure to solder lug 2 of V5 to the center post.
- () Cut 1-1/2" of BARE lead. Connect it from V1 lug 4 (NS) through V1 center post (NS) to V1 lug 2 (S-1).
- () Cut 1-1/2" of BARE lead. Connect it from L4 lug 2 (NS) to E9 (NS).
- () Cut 2" of BARE lead. Connect it from E9 (NS) to T3 lug E (S-1).

NOTE: Do not allow this wire to touch the chassis at any point other than E9.
- () Cut 2" of BARE lead. Connect it from E9 (S-3) to V6 center post (NS).
- () Push V6 lug 2 to center post and solder (S-2).
- () Cut 3" of BARE lead. Connect it from E8 (NS) to L5 lug 3 (NS).
- () Cut 2-1/4" of BARE lead. Connect it from E (S-1) to E11 (NS).
- () Push V7 lug 2 to V7 center post (NS).
- () Cut 2-1/4" of BARE lead. Connect it from E11 (NS) through V7 center post (S-2) to V7 lug 4 (NS). Be sure to solder lug 2 of V7 to the center post.
- () Cut 1-1/2" of BARE lead. Connect it from L6 lug 2 (NS) to E11 (NS).
- () Cut 2" of BARE lead. Connect it from E12 (NS) to V8 center post (S-1).
- () Cut 1-1/2" of BARE-BRAIDED lead. Connect it from C31 lug 1 (S-1) to E1 (NS).
- () Cut 1" of BARE-BRAIDED lead. Connect it from C30 lug 1 (S-1) to E2 (NS).

23. () Cut 2" of BARE-BRAIDED lead. Connect it from E2 (S-3) to S6 lug 1 (S-1).
24. () Locate BARE-BRAIDED lead coming from the OSC section of the Coil Assembly. Connect it straight to E6 (NS). Trim off excess.
25. () Locate BARE-BRAIDED lead coming from the RF section of the Coil Assembly. Connect it straight to E7 (NS). Trim off excess.
26. () Locate BARE-BRAIDED lead coming from the ANT section of the Coil Assembly. Connect it straight to E8 (NS). Trim off excess.
27. () Cut 13" of RED lead. Connect it from S1 lug 4 (S-1) to L2 lug 3 (NS).
28. () Connect RED lead coming through hole H7 to C31 lug 2 (S-1).
29. () Connect the BLACK lead coming through H7 to V5 lug 4 (NS) and connect the YELLOW lead to V5 lug 3 (NS).
30. () Connect the BLUE lead coming through H7 to L1 lug 1 (NS).
31. () Connect the inner conductor of the BLACK, SINGLE-CONDUCTOR, SHIELDED cable (coming through H7) to S4 lug 4 (S-1).
NOTE: Switch S4 is mounted on R26.
32. () Connect the BRAIDED-SHIELD lead of the cable referred to in Step 31 to E1 (S-3).
33. () Cut 2-1/4" of BLACK lead. Connect it from E6 (NS) to V3 center post (S-1).
34. () Cut 2-1/4" of BLACK lead. Connect it from E7 (NS) to V2 center post (NS).
35. () Cut 2-1/4" of BLACK lead. Connect it from E8 (S-3) to V1 center post (S-2).
36. () Cut 4-1/2" of heavy BLACK lead. Connect it from V3 lug 4 (S-2) to V2 lug 4 (NS).
37. () Cut 3-5/8" of heavy YELLOW lead. Connect it from V3 lug 3 (S-2) to V2 lug 3 (NS).
38. () Cut 3" of heavy YELLOW lead. Connect it from T1 lug 3 (NS) to T7 lug 4 (S-1).
39. () Cut 9-1/2" of heavy BLACK lead. Connect it from T7 lug 3 (S-1) to S1 lug 2 (NS).
40. () Cut 3-3/8" of heavy BLACK lead. Connect it from V1 lug 4 (NS) to V5 lug 4 (S-2).
41. () Cut 5" of heavy BLACK lead. Connect it from V1 lug 4 (S-3) to V6 lug 4 (NS).
42. () Cut 5" of heavy YELLOW lead. Connect it from V1 lug 3 (NS) to V6 lug 3 (NS).
43. () Cut 3-1/2" of heavy YELLOW lead. Connect it from V1 lug 3 (S-2) to V5 lug 3 (S-2).
44. () Cut 5-1/2" of heavy BLACK lead. Connect it from V7 lug 4 (NS) to V6 lug 4 (S-2).
45. () Cut 6-1/2" of heavy YELLOW lead. Connect it from V7 lug 3 (NS) to V6 lug 3 (S-2).
46. () Cut 4" of heavy YELLOW lead. Connect it from V8 lug 3 (NS) to V7 lug 3 (S-2).
47. () Cut 4-3/8" of heavy BLACK lead. Connect it from V8 lug 4 (NS) to V7 lug 4 (S-3).
48. () Cut 10-5/8" of heavy YELLOW lead. Connect it from T1 lug 4 (NS) to V8 lug 3 (S-2).
49. () Cut 10-5/8" of heavy BLACK lead. Connect it from T1 lug 5 (NS) to V8 lug 4 (S-2).
50. () Cut 8-3/4" of BLUE lead. Connect it from R24 lug 3 (S-1) to L3 lug 3 (NS).
51. () Cut 6-3/8" of BLUE lead. Connect it from S6 lug 2 (S-1) to L3 lug 1 (NS).

52. () Cut 8-3/4" of BLUE lead. Connect it from L3 lug 1 (NS) to L5 lug 1 (NS).
53. () Cut 14" of BLUE lead. Connect it from L3 lug 3 (NS) to R28 lug 1 (S-1).
54. () Cut 15-3/4" of WHITE lead. Connect it from L7 lug 4 (NS) to V5 lug 7 (NS).
55. () Connect the BROWN lead (tagged B) coming from the RF section of the Coil Assembly to L2 lug 3 (NS).
56. () Cut 3-3/8" of RED lead. Connect it from T2 lug P (NS) to V2 lug 5 (S-1).
57. () Cut 2-3/4" of RED lead. Connect it from T2 lug B (NS) to V2 lug 6 (NS).
58. () Cut the RED lead (tagged P) coming from the RF section of the Coil Assembly to a length long enough to reach 1/2" past V1 lug 5. Trim and tin this lead. Connect it to V1 lug 5 (S-1).
59. () Cut 2-3/4" of RED lead. Connect it from V1 lug 6 (S-1) to point B (S-1). (Point B is located in the RF section of the Coil Assembly.)
NOTE: Wrap the RED lead around the already soldered point B.
60. () Cut 1-3/8" of YELLOW lead. Connect it from V3 lug 1 (NS) to V2 lug 1 (S-1).
61. () Cut 1-3/8" of YELLOW lead. Connect it from T2 lug I (S-1) to V5 lug 1 (S-1).
62. () Cut 1-5/8" of RED lead. Connect it from V5 lug 6 (NS) to T3 lug B (NS).
63. () Cut 1-3/8" of RED lead. Connect it from V5 lug 5 (S-1) to T3 lug P (S-1).
64. () Cut 2" of YELLOW lead. Connect it from T3 lug I (S-1) to V6 lug 1 (S-1).
65. () Cut 1-5/8" of WHITE lead. Connect it from L4 lug 1 (NS) to V6 lug 7 (NS).
66. () Cut 2-3/8" of YELLOW lead. Connect it from V7 lug 5 (S-1) to T4 lug I (S-1).
67. () Cut 4-3/8" of RED lead. Connect it from L5 lug 4 (NS) to L4 lug 3 (NS).
68. () Cut 5-1/2" of RED lead. Connect it from V8 lug 6 (NS) to L5 lug 4 (NS).
69. () Cut 2" of YELLOW lead. Connect it from V8 lug 1 (NS) to L6 lug 1 (NS).
70. () Cut 4" of RED lead. Connect it from T1 lug 7 (S-1) to V9 lug 4 (S-1).
71. () Cut 4-3/4" of RED lead. Connect it from T1 lug 9 (S-1) to V9 lug 6 (S-1).
72. () Cut 3" of YELLOW lead. Connect it from T1 lug 10 (S-1) to V9 lug 2 (S-1).
73. () Cut 3-3/8" of YELLOW lead. Connect it from T1 lug 11 (NS) to V9 lug 8 (NS).
74. () Cut the RED lead coming through hole H8 to a length of 12-1/2", measuring from H8. Connect it to R28 lug 2 (S-1).
75. () Cut the WHITE lead coming through hole H8 to a length of 6-3/4" measuring from H8. Connect it to L7 lug 5 (NS).
76. () Cut 19" of RED lead. Connect it from S1 lug 5 (S-1) to Y, lug 5 (S-1).
77. () Cut 5-1/2" of RED lead. Connect it from C26-27 lug 1 (S-1) to L7 lug 2 (NS).
78. () Cut 6-1/4" of RED lead. Connect it from C26-27 lug 2 (S-1) to T1 lug 11 (NS).
79. () Cut 7-5/8" of RED lead. Connect it from L7 lug 2 (NS) to V8 lug 6 (S-2).
80. () Cut 2-3/8" of RED lead. Connect it from T4 lug B (NS) to V6 lug 6 (NS).

81. () Cut 2" of RED lead. Connect it from T4 lug P (S-1) to V6 lug 5 (S-1).
82. () Cut 9-1/8" of WHITE lead. Connect it from R28 lug 3 (S-1) to L4 lug 1 (S-2).
83. () Cut 2-3/8" of RED lead. Connect it from L5 lug 4 (NS) to Y, lug 1 (S-1).
84. () Twist the BLACK lead (tagged E) and the WHITE lead (tagged ANT), both coming from the ANT section of the Coil Assembly, together. Cut the WHITE lead to the same length as the BLACK lead and tin both. Connect the WHITE lead to A1 (S-1) and the BLACK lead to A2 (S-1).
85. () Cut 3-1/4" of BLACK lead. Connect it from B, lug 3 (NS) to E12 (NS).
86. () Cut the YELLOW lead coming through hole H3 to a length of 1-3/8" measuring from H3. Tin this lead. Connect it to L7 lug 1 (NS).
87. () Cut the GREEN lead coming through hole H3 to a length of 3" measuring from H3. Tin this lead. Connect it to B, lug 2 (S-1).
88. () Cut the BLACK lead coming through hole H3 to a length of 3" measuring from H3. Tin this lead. Connect it to B, lug 3 (S-2).
89. () Cut the RED lead coming from hole H3 to a length of 2-1/2" measuring from H3. Tin this lead. Connect it to V9 lug 8 (NS).
90. () Connect the BLUE lead coming through hole H3 to V8 lug 5 (NS).
91. () Cut 5-1/8" of YELLOW lead. Trim 1/4" of insulation off one end and connect it to S1 lug 1 (S-1). Trim off 5/8" of insulation from the other end. Run this bared end through S3 lug 3 (S-1) and connect it at S3 lug 4 (NS).
92. () Cut 4-3/4" of YELLOW lead. Trim off 1/4" of insulation from one end and connect it to T1 lug 1 (S-1). Trim off 5/8" of insulation from the other end. Run this bared end through S3 lug 1 (S-1) and connect it at S3 lug 2 (S-1).
93. () Cut 4-3/4" of WHITE lead. Trim off 1/4" of insulation from one end and connect it to T1 lug 2 (S-1). Trim off 5/8" of insulation from the other end. Run this bared end through S3 lug 5 (S-1) and connect it at S3 lug 6 (S-1).
94. () Cut 10-5/8" of BLUE lead. Connect it from J2 lug 3 (S-1) to L7 lug 1 (S-2).
95. () Cut 13-1/2" of WHITE lead. Connect it from J2 lug 2 (S-1) to B, lug 1 (S-1).
96. () Cut 2-3/8" of YELLOW lead. Connect it from T1 lug 3 (S-2) to F, lug 1 (S-1).
97. () Connect the BLACK lead coming through hole H8 to T1 lug 5 (S-2).
98. () Connect the YELLOW lead coming through hole H8 to T1 lug 4 (S-2).
99. () Cut 2-3/4" of RED lead. Connect it from S1 lug 6 (S-1) to L1 lug 3 (NS).
100. () Cut 9-1/4" of BLUE lead. Connect it from S4 lug 5 (S-1) to L2 lug 1 (NS).
101. () Place the GREEN lead (tagged K) so that it runs over V3 lug 2. Cut this wire about 1/2" past lug 2. Connect it to V3 lug 2 (S-1).
102. () Cut 5-1/2" of YELLOW lead. Connect it from C30 lug 2 (S-1) to point RFG in the ANT section. Solder this connection. (RFG is the upper lug on the coil.)
103. () Cut 16-3/4" of 2-conductor, BLACK, SHIELD cable. Prepare both ends as follows: (see Fig. 1). Remove 1-1/2" of outer insulation. Push the shield back exposing the two inner conductors. At one end, twist the strands of the shield together and tin. At the other end, trim off the shield. Trim off a 1/4" of insulation from the two inner conductors at both ends.

104. () Connect the RED and BLACK leads (at the end with no shield) to S5 lugs 1 and 2, respectively. Solder both connections. Connect the RED lead (at the other end) to L6 lug 1 (NS); connect the BLACK lead to V7 lug 6 (S-1); and connect the shield to E11 (S-4).
105. () Cut 15-1/2" of SINGLE-CONDUCTOR SHIELDED cable. At both ends, remove 3/4" of outer insulation. Push the shield back exposing the inner conductor. Twist the strands of the shield together and tin. Remove 1/4" of insulation from the inner conductor and tin. The cable should appear as in Figure 1D. Proceed to the next step.
106. () Connect the inner conductor of the cable referred to in Step 105 from R25 lug 3 (S-1) to L5 lug 2 (NS). Connect the shield from R25 lug 1 (NS) to L5 lug 3 (S-2).
107. () Cut 13" of SINGLE-CONDUCTOR SHIELDED cable. Prepare this cable in exactly the manner the cable in Step 105 was prepared.
108. () Connect the inner conductor of the cable referred to in Step 107 from R25 lug 2 (S-1) to L6 lug 3 (NS). Connect the shield from R25 lug 1 (S-2) to L6 lug 2 (NS).
109. () Split the leads of the AC line cord down to a point 1-1/2" away from the strain relief, H6. From this point, cut one lead to 1-1/2" in length. Leave the other lead full length. Trim, tin and connect the shorter lead to F lug 2 (S-1). Connect the longer lead to S1 lug 2 (S-2).
110. () Cut the supplied strip of metal into three 2" lengths. Bend each 2" length into a U-shape. Place one U-shaped metal strip over the leads located in the area of hole H5; then, put the metal strip through hole H5; and bend both sides of the strip flat against the top of the chassis. Do the same with the other metal strips at holes H1 and H4. Do not squeeze the leads too tightly;

FOR THE FOLLOWING STEPS, REFER TO PICTORIAL 3.

111. () Cut a 26" length of BLACK lead, and 26" length of WHITE lead. Twist this pair together (not the bare ends, however). At one end, connect the BLACK lead to V2 lug 4 (NS) and the WHITE lead to V2 lug 3 (S-2). Now push lug 4 of V2 against the center post and then solder lug 4 to the post (S).
112. () Route the twisted pair of leads as shown in Pictorial 3. Connect the free ends of the BLACK and WHITE twisted pair as follows: Black to T7 lug 1; white to T7 lug 2. Solder each terminal lug.

WIRING IN THE COMPONENTS

(Refer to Pictorial 3)

WIRING

NOTE: Be sure to read Notes (a), (b), (c) and (d) on Page 7 before proceeding.

1. () C9, 0.005 μ fd, disc. Cut both leads to 1". Connect it from L2 lug 1 (S-2) to T2 lug P (S-2).
2. () R11, 1K, 1/2W. Cut both leads to 1-1/8". Connect it from L2 lug 3 (NS) to T2 lug B (S-2).
3. () R7, 1K 1/2W. Cut both leads to 1/2". Connect it from L2 lug 3 (S-4) to V3 lug 5 (NS).
4. () C7, 0.01 μ fd, disc. Cut both leads to 5/8". Cut, also, 3/8" of protective sleeving and place it over one of the leads. Connect the lead with the sleeving to V3 lug 5 (S-3). Connect the other lead to terminal post marked P and located in the OSC section of the Coil Assembly. Solder this connection.
5. () C8, 100 μ fd, mica. Cut both leads to 7/8". Connect from V3 lug 1 (NS) to terminal G1 (S-2) located in the OSC section of the coil assembly (be sure to use the uppermost terminal as viewed).
6. () R6, 22K, 1/4W. Cut both leads to 1/2". Connect from V3 lug 1 (S-3) to E6 (NS).

Pictorial 3

UNDERCHASSIS WIRING

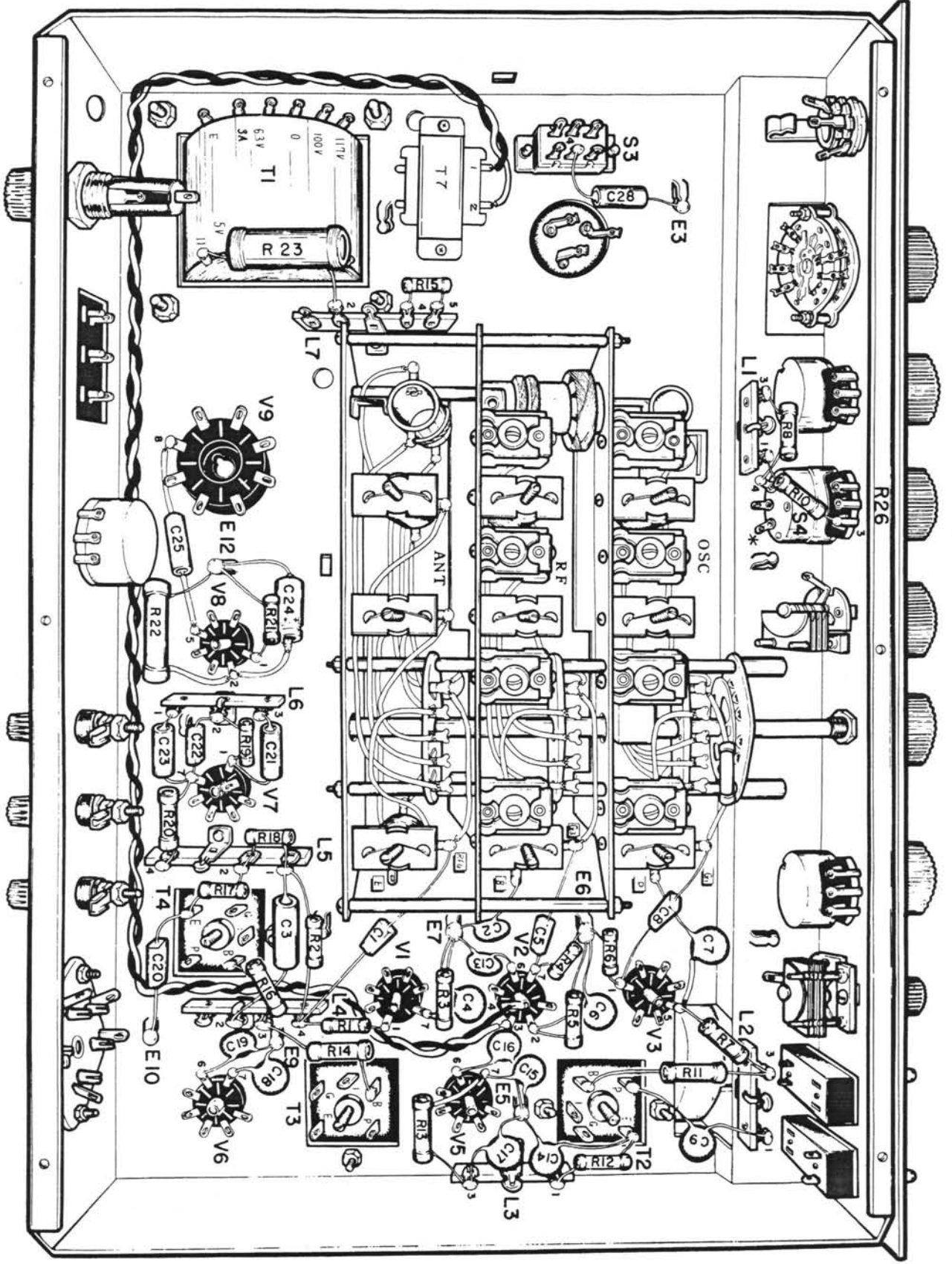

* THIS LUG IS NEVER USED

7. () C6, 0.01 μ fd, disc. Cut both leads to 7/8". Connect it from E6 (S-4) to V2 lug 2 (NS).
8. () R5, 330 Ω , 1/2W. Cut both leads to 5/8". Connect one lead to V2 lug 2 (S-2). Twist the other lead twice around any one of the leads going to E6 and solder.
9. () R4, 1M Ω , 1/4W. Cut both leads to 5/8". Connect one lead to V2 lug 7 (NS). Twist the other lead twice around any one of the leads going to E6 and solder.
10. () C5, 250 μ fd, mica. Cut both leads to 5/8". Connect from V2 lug 7 (S-2) to terminal G3 (S-2) in the RF section of the coil assembly (be sure to use the uppermost terminal, as viewed).
11. () C2, 0.01 μ fd, disc. Cut both leads to 1/2" Connect one lead to terminal B (in the RF coil section) and solder. Connect the other lead to E7 (NS).
12. () C13, 0.01 μ fd, disc. Cut both leads to 1/2". Connect it from V2 lug 6 (S-2) to E7 (S-4).
13. () C4, 0.01 μ fd, disc. Cut both leads to 5/8". Connect one lead to V1 lug 7 (NS). Twist the other lead twice around any one of the leads going to E7 and solder.
14. () R3, 330 Ω , 1/2W. Cut both leads to 5/8". Connect one lead to V1 lug 7 (S-2). Twist the other lead twice around any one of the leads going to E7 and solder.
15. () R12, 100K Ω , 1/4W. Cut both leads to 5/8". Connect from T2 lug E (NS) to L3 lug 1 (S-3).
16. () C14, 0.01 μ fd, disc. Cut both leads to 3/4". Connect it from T2 lug E (S-2) to E5 (NS).
17. () C17, 0.01 μ fd, disc. Cut both leads to 5/8". Connect from L3 lug 3 (NS) to E5 (S-3).
18. () C16, 0.01 μ fd, disc. Cut both leads to 5/8". Connect one lead to V5 lug 6 (S-2). Twist the other lead twice around any one of the leads going to E5 and solder.
19. () C15, 0.01 μ fd, disc. Cut both leads to 1/2". Connect one lead to V5 lug 7 (NS). Twist the other lead twice around any one of the leads going to E5 and solder.
20. () R13, 330 Ω , 1/2W. Cut both leads to 5/8". Cut, also, 3/8" of protective sleeving and place it over one of the leads. Connect the lead with the sleeving to V5 lug 7 (S-3). Connect the other lead to L3 lug 3 (S-4).
21. () C1, 250 μ fd, mica. Cut both leads to 1". Connect it from L4 lug 4 (NS) to terminal RFG (S-2) in the ANT section of the coil assembly (be sure to use the uppermost terminal).
22. () R1, 47 Ω , 1/4W. Cut both leads to 1/2". Connect it from V1 lug 1 (S-1) to L4 lug 4 (NS).
23. () R14, 1K Ω , 1/2W. Cut both leads to 3/4". Connect it from T3 lug B (S-2) to L4 lug 3 (NS).
24. () C18, 0.01 μ fd, disc. Cut both leads to 1/2". Connect it from E9 (NS) to V6 lug 7 (S-2).
25. () C19, 0.01 μ fd, disc. Cut both leads to 3/4". Connect it from E9 (S-5) to V6 lug 6 (S-2).
26. () R2, 1M Ω , 1/4W. Cut both leads to 1". Connect it from L5 lug 1 (NS) to L4 lug 4 (S-3).
27. () C3, 0.05 μ fd, tubular. Cut both leads to 1". Connect it from L5 lug 1 (NS) to L4 lug 2 (S-2).
28. () R16, 1K Ω , 1/2W. Cut both leads to 1/2". Connect it from T4 lug B (S-2) to L4 lug 3 (S-3).
29. () C20, 100 μ fd, mica. Cut both leads to 1". Connect it from E10 (S-1) to T4 lug E (NS).
30. () R17, 47K Ω , 1/4W. Cut both leads to 5/8". Connect it from T4 lug E (S-2) to L5 lug 2 (NS).
31. () R18, 2.2M Ω , 1/4W. Cut both leads to 1/2". Connect it from L5 lug 1 (S-4) to L5 lug 2 (S-3).
32. () C21, 0.01 μ fd, tubular. Cut both leads to 3/4". Connect it from L6 lug 3 (S-2) to V7 lug 1 (NS).

33. () R19, 4.7M Ω , 1/4W. Cut both leads to 1/2". Connect it from L6 lug 2 (NS) to V7 lug 1 (S-2).
34. () C22, 100 μ fd, mica. Cut both leads to 1/2". Connect it from L6 lug 2 (S-4) to V7 lug 7 (NS).
35. () C23, 0.01 μ fd, tubular. Cut both leads to 3/4". Connect it from L6 lug 1 (S-3) to V7 lug 7 (NS).
36. () R20, 220K Ω , 1/2W. Cut both leads to 1/2". Connect from V7 lug 7 (S-3) to L5 lug 4 (S-4).
37. () C24, 10 μ fd, electrolytic, 50WV. Cut both leads to 1". Cut, also, 3/4" of sleeving and place it over the lead coming from the side marked positive (+). Connect this lead to V8 lug 2 (NS). Connect the other lead to E12 (NS).
38. () R21, 470K Ω , 1/4W. Cut both leads to 5/8". Connect from V8 lug 1 (S-2) to E12 (NS).
39. () C25, 0.005 μ fd, tubular. Cut both leads to 1-1/4". Cut, also, two 1" lengths of protective sleeving and place these over both leads. Connect C25 from V8 lug 5 (S-2) to V9 lug 8 (S-3).
40. () R22, 470 Ω , 1W. Cut both leads to 1/2". Cut, also, a 1/4" of protective sleeving and place it over one of the leads. Connect this lead to V8 lug 2 (S-2). Twist the other lead to any of the leads going to E12 and solder all connections on E12 (S-5).
41. () R8, 22K Ω , 1/2W. Cut both leads to 3/4". Connect from L1 lug 3 (S-2) to S4 lug 4 (S-2).
42. () R10, 3.3K, 1/2W. Cut both leads to 5/8". Connect it from R26 lug 3 (S-1) to L1 lug 1 (S-2).
43. () C28, 0.01 μ fd, tubular. Cut both leads to 3/4". Cut, also, 1/2" of protective sleeving and place it over one of the leads. Connect this lead to S3 lug 4 (S-2). Connect the other lead to E3 (S-3).
44. () R15, 2.2K Ω , 1/4W. Cut both leads to 1/2". Connect it from L7 lug 4 (S-2) to L7 lug 5 (S-2).
45. () R23, 2K Ω , 10W. Cut both leads to 3/4". Connect it from L7 lug 2 (S-3) to T1 lug 11 (S-3).

This completes the wiring of the KT-340.

46. () Insert the nine tubes into their correct sockets. (Tube types are stamped into the chassis alongside their proper sockets.)
47. () Slip the tube clips over the miniature tubes. Check that the clip does not interfere with wiring on the underside of the chassis.
48. () Make sure voltage selector switch on the top of the chassis is in the "117V" position.
49. () Do not plug in receiver, but place FUNCTION switch in "REC AM" position.
50. () Make sure the 5-pin jumper plug is inserted into the socket at the rear of the receiver.

PRELIMINARY CHECKS

The construction of your KT-340 is now completed. Before proceeding any further, check over the wiring carefully to make sure that you have not made any errors or have left any connections unsoldered. If possible, have a friend check the construction with you, as there is a tendency for a person to repeat his errors. If a multimeter is available, the following DC resistance measurements should be made before plugging the unit into the power line. Check for a resistance of approximately 6 ohms between the prongs of the line cord; a minimum resistance of approximately 18K ohms from V9 lug 8 to ground (Because of capacitive charging, the reading, at first, should be very small. However, as the capacitor, C27, charges, the reading should rise to a value of approximately 18K ohms.)

NOTE: Generous quantities of wire and cable were supplied with this kit. You may therefore find that there are several lengths of wire remaining after completion of the kit. This is quite normal.

1. () If the unit passes the resistance tests above satisfactorily, return the FUNCTION switch to the OFF position and then plug the line cord plug into an AC outlet (105-120 volts, 60 cycle).
2. () Set the FUNCTION switch to REC AM. Check to see that the pilot lamps light and that the filaments in all tubes glow. If they do not, or if there is any sign of overheating, switch the receiver off and refer to the "In The Event of Difficulty Section".

3. () We now suggest that you read the information provided on pages 24 through 29 to familiarize yourself with the receiver (leave the receiver turned on in the meantime). When you have read this section, connect a speaker to the OUTPUT terminals and attach a length of antenna wire to the A1 antenna terminal (making sure A2 and E are shorted together). Set all controls on the receiver to the positions prescribed for AM SETTINGS in the section "INITIAL CONTROL SETTINGS" on page 26. Set the BAND SEL switch to ".55 - 1.6" (broadcast band).
4. () Make sure the IF GAIN is at maximum, and the SELECTIVITY control is fully clockwise to operate the switch.
5. () With the AF GAIN control turned up, tune across the dial. You should be able to receive all local broadcast stations quite strongly. By adjusting ANT TRIM control, you should be able to peak the signal. Check each of the other bands for any stations that you may be able to pick up. If the receiver appears to be operating satisfactorily, unplug the unit and proceed with the installation of the covers, as instructed in steps 6 and 7.

However, if there appears to be a lack of sensitivity, even when using a proper outdoor antenna, the receiver may be in need of alignment. Even though coils and transformers in this unit have been pre-aligned, certain variations in wiring are bound to occur in kit construction. Because of this, and also because of the normal tolerances of the components associated with the tuned circuits, slight receiver realignment may be necessary to produce optimum results. This will be particularly true of the higher short-wave bands where adjustments are more critical.

A complete alignment procedure is provided on page 20. If you do not have the necessary test equipment, we suggest you make an attempt to obtain the equipment from a friend or other source. Failing this, your local serviceman can be consulted on this matter. If you so desire, the receiver may be sent to Lafayette -- the charge for complete alignment being \$9.50. Remember, however, that this charge is for alignment only. Any repair work which must be carried out to correct errors in wiring or other troubles will result in additional charges being made. (See section "Servicing" on page 33.)

6. () Install bottom cover and fasten, with four screws, to the chassis.
7. () Install the top cover and fasten, with four knurled screws at the sides, to the chassis.

IN THE EVENT OF DIFFICULTY

- A. If all of the tubes remain unlit when the receiver is turned on, or if they suddenly go off, check to see that the fuse is intact. If not, replace it with one of the same value (see parts list). Should the receiver still fail to operate, or should the fuse blow again, check for an error in wiring or a component failure.
- B. Carefully re-check all wiring and values of components inserted against the instructions. If you have not already done so, trace each lead and component in the pictorials with a colored pencil. It is frequently helpful to have a friend check your work with you as there is a tendency for the constructor to repeat his errors.
- C. Inspect all solder connections carefully. A large number of kits returned for repair have been found defective due to poor solder connections. Therefore, any doubtful connections should be re-heated to make sure they are correctly soldered.
- D. Check for small pieces of solder or wire which may have fallen into the chassis. Make sure that the use of excess solder has not caused a short between adjacent terminals or nearby wiring, particularly on tube sockets and switch terminals.
- E. If you are still unable to locate the trouble and a voltmeter is available, check the voltage readings, referring to the voltage chart. A variation of $\pm 15\%$ may be considered normal.

If there are obvious signs of a short circuit (components becoming discolored or smoking) do not attempt to make voltage checks. Switch the unit off and remove the AC plug until the short circuit has been located and the trouble corrected.

CAUTION: EXERCISE GREAT CARE WHEN MAKING ANY CHECKS WITH THE UNIT TURNED ON. If any voltage is incorrect, recheck that part of the circuit involved carefully. If the wiring and connections have already been checked and found correct, the trouble will in all probability be due to a defective part (tube, capacitor, resistor, etc.).

VOLTAGE MEASUREMENTS

Voltages taken with receiver controls in the following positions

BANDSPREAD pointer at 0 on Logging Scale

MAIN TUNING pointer at 0 on Logging Scale

FUNCTION switch on REC AM

AF GAIN control fully counter-clockwise (minimum)

SELECTIVITY control on AM-CW-SSB

BFO-Q-MULT FREQUENCY control on mid-position (white dot)

BAND SEL on .55-1.6

IF GAIN control fully counter-clockwise (minimum)

MVC-AVC switch on AVC

ANL switch on "off" position

Short A1, A2 and E with jumper wire

Voltage selector switch in 117 volt position

SOCKET PIN NUMBERS
(See Pictorial 2 for socket locations.)

	1	2	3	4	5	6	7	8	9
RF									
V1 (6BA6)	0	0	6.3V AC	0	135	135	3.5	-	-
MIXER									
V2 (6BE6)	-7.7	3.6	6.3V AC	0	125	125	0	-	-
OSC									
V3 (6BE6)	-7.7	0	6.3V AC	0	125	125	125	-	-
1st IF									
V5 (6BA6)	0	0	6.3V AC	0	135	135	19	-	-
2nd IF									
V6 (6BA6)	0	0	6.3V AC	0	135	135	19	-	-
Detector, ANL									
1st audio									
V7 (6AV6)	-.35	0	6.3V AC	0	-.06	-.08	70	-	-
Audio Output									
V8 (6AQ5)	0	7	6.3V AC	0	200	135	NC	-	-
Rectifier									
V9 (5Y3)	NC	205	NC	200 (AC)	NC	200 (AC)	NC	205	-
Q-MULT									
* V4 (6AV6)	**2.2 Meg	**3.3 K	6.3V AC	0	0	0	135	-	-

* Place FUNCTION in Q-MULT position and remove V4 from socket. Check voltages from top of socket (numbering is now counter-clockwise)

** Resistance measurements taken at these pins - REMOVE AC POWER FROM RECEIVER FIRST

1. Voltages taken with 20,000 ohms per volt meter and, unless otherwise noted, measured from chassis ground to joint indicated.
2. Line voltage maintained at 117V AC for these measurements.
3. Tolerance on components permits a variation of $\pm 15\%$ in readings.
4. All voltages DC unless otherwise noted.

ALIGNMENT

Your KT-340 comes completely pretuned and prealigned. However, for optimum results, it is suggested that you follow the alignment procedure as prescribed below.

(A receiver with a lack of sensitivity or selectivity, or oscillation, may be in need of re-alignment. However, other factors may cause the same complaint. These include weak tubes, open bypass condensers, etc., which must first be investigated. Be sure that the receiver is perfect in all other respects before resorting to re-alignment.)

CHASSIS REMOVAL

The top cover is held by four screws - two each side. The bottom cover is held by six screws on the underside of the unit.

IF ALIGNMENT

EQUIPMENT REQUIRED:

AC Voltmeter
Calibrated RF Signal Generator
Non-Metallic Alignment Tool (GC No. 8722 or equiv.)

1. Connect a loudspeaker to the output terminals. Remove the local oscillator V3, 6BE6, from its socket.
2. Set the receiver controls as follows:
FUNCTION switch on REC AM
AF GAIN control to maximum
SELECTIVITY control on AM-CW-SSB
IF GAIN control 3/4 full position
MVC - AVC switch on MVC
ANL off
3. Connect the voltmeter (3 volt AC range) across the speaker terminals.
4. Connect the signal generator between pin 7 of V2 socket (6BE6 mixer tube - see Pict. 2) and ground.
5. Set the signal generator at 455KC and modulate it with either 400 or 1000 cycles (30%).
6. Adjust the secondary and primary of IF transformers T4, T3 and T2 (see Fig. A). Follow the order given - secondary first, then primary in each case. Topside adjustments are secondaries, bottom of chassis adjustments are primaries.

During alignment, lower the generator output progressively to prevent overloading. Repeat alignment until no further improvement is noted.

BFO AND Q-MULTIPLIER ADJUSTMENT

1. All receiver controls should be set as in the IF alignment with the exception of the following:
FUNCTION switch to Q-MULT
BFO-Q-MULT FREQUENCY to mid-position (dot)*
Reduce AF GAIN
2. Set the generator to 455KC, unmodulated RF.
3. Adjust the BFO coil T6 (located next to V4, Q-MULT) until a zero beat is heard (also accompanied by a minimum reading on voltmeter. Note that the minimum point will be bracketed by a peak on each side.)

*If necessary, reposition the BFO control knob on its shaft, so that when it is in the 12 o'clock position, the plates of the BFO tuning capacitor are fully meshed.

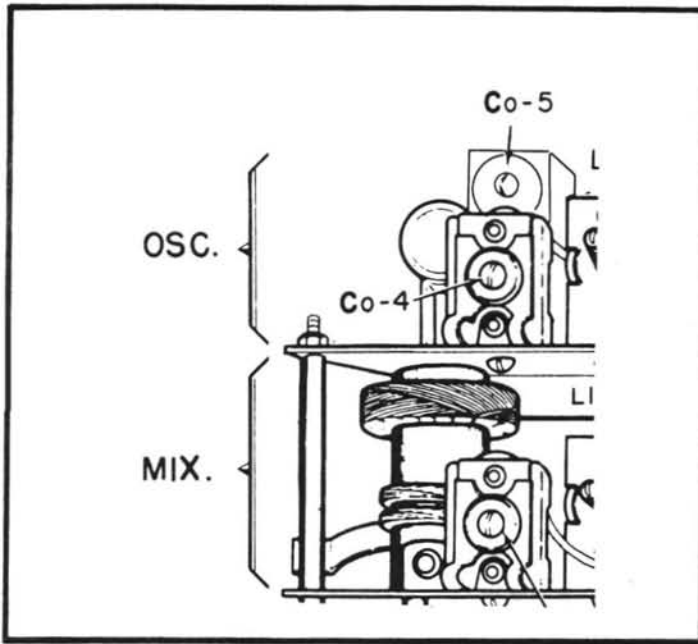

THESE TWO ADJUSTMENTS MADE
WITH BOTTOM COVER REMOVED-
REMAINDER OF RF ALIGNMENT
CARRIED OUT WITH COVER IN PLACE

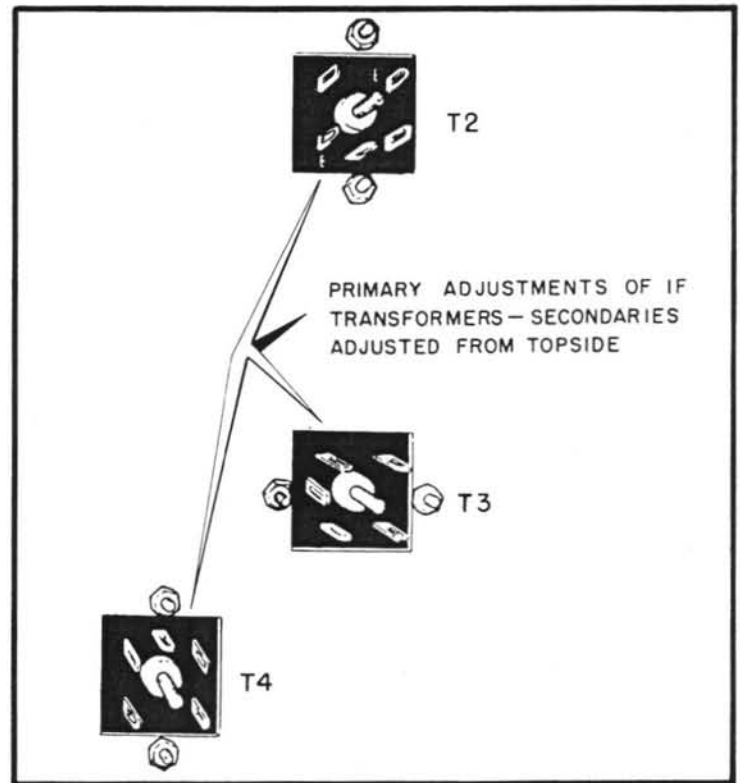
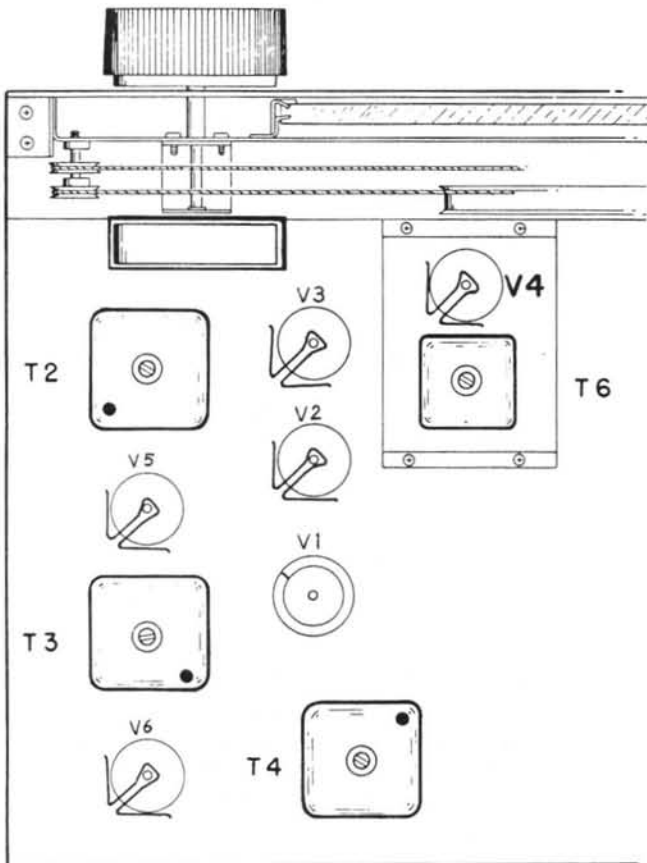

FIGURE A

RF ALIGNMENT CHART

STEP	BAND SELECTOR	SIGNAL GENERATOR	MAIN TUNING	ADJUST	REMARKS	VIEW
1	.55-1.6	.6 MC (600KC)	.6 MC	Co-5 (Osc) *	Adjust for peak reading on voltmeter	Figure A
2	.55-1.6	1.4 MC (1400KC)	1.4 MC	Co-4 (Osc)		
Repeat steps 1 & 2 until calibration is correct at both ends of scale (.6 and 1.4 MC). The remainder of the alignment must be carried out with the bottom cover in place. Remove power first.						
3	.55-1.6	1.4 MC (1400KC)	1.4 MC	Cm-4 (mixer)	Adjust for peak reading on voltmeter	
4	1.6-4.8	2.0 MC	2.0 MC	Lo-3 (Osc)		
5	1.6-4.8	4.0 MC	4.0 MC	Co-3 (Osc)		
Repeat steps 4 and 5 until calibration is correct at both ends of the scale (2.0 and 4.0 MC)						
6	1.6-4.8	2.0 MC	2.0 MC	Lm-3 (mixer)	Adjust for peak reading on voltmeter	
7	1.6-4.8	4.0 MC	4.0 MC	Cm-3 (mixer)		
Repeat steps 6 and 7 until calibration is correct at both ends of the scale (2.0 and 4.0 MC)						
8	1.6-4.8	2.0 MC	2.0 MC	La-3 (Ant)	Adjust for peak reading on voltmeter	Figure B
9	4.8-14.5	5.0 MC	5.0 MC	Lo-2 (Osc)		
10	4.8-14.5	14.0 MC	14.0 MC	Co-2 (Osc)		
Repeat steps 8 and 9 until calibration is correct at both ends of the scale (5.0 and 14.0 MC)						
11	4.8-14.5	5.0 MC	5.0 MC	Lm-2 (mixer)	Adjust for peak reading on voltmeter	
12	4.8-14.5	14.0 MC	14.0 MC	Cm-2 (mixer)		
Repeat steps 11 and 12 until calibration is correct at both ends of the scale (5.0 and 14.0 MC)						
13	4.8-14.5	5.0 MC	5.0 MC	La-2 (Ant)	Adjust for peak reading on voltmeter	
14	10.5-30	13.0 MC	13.0 MC	Lo-1 (Osc)		
15	10.5-30	28.0 MC	28.0 MC	Co-1 (Osc)		
Repeat steps 14 and 15 until calibration is correct at both ends of scale (13.0 and 28.0 MC)						
16	10.5-30	13.0 MC	13.0 MC	Lm-1 (mixer)	Adjust for peak reading on voltmeter	
17	10.5-30	28.0 MC	28.0 MC	Cm-1 (mixer)		
Repeat steps 16 and 17 until calibration is correct at both ends of scale (13.0 and 28.0 MC)						
18	10.5-30	13.0 MC	13.0 MC	La-1 (Ant)	Adjust for peak reading on voltmeter	

*NOTE: On all bands, the oscillator should be set on the high frequency side of the incoming signal.

RF ALIGNMENT

1. Turn power off. Replace V3, 6BE6 local oscillator, in its socket. Turn power on (allow 2 min. warm up).
2. Using a short jumper wire, connect antenna terminals A2 and E together.
3. Connect AC voltmeter (3 volt range) and loudspeaker across speaker terminals.
4. Connect the modulated output of the RF signal generator to antenna terminals A1 and E.
5. Rotate the ANT TRIM control until the capacitor plates are half-meshed. If the indicator dot on control knob is not at the 12 o'clock position, loosen set screw, place knob in this position and tighten screw again (without disturbing position of capacitor plates). Do not change control from the 12 o'clock position until alignment is completed.
6. Set all receiver controls as for IF alignment. Set BANDSPREAD pointer at 100 on Logging Scale and make sure FUNCTION switch is on REC AM.
7. Carry out alignment as indicated in the chart.
 Note: Lower generator output progressively to prevent overloading as circuits come into line.

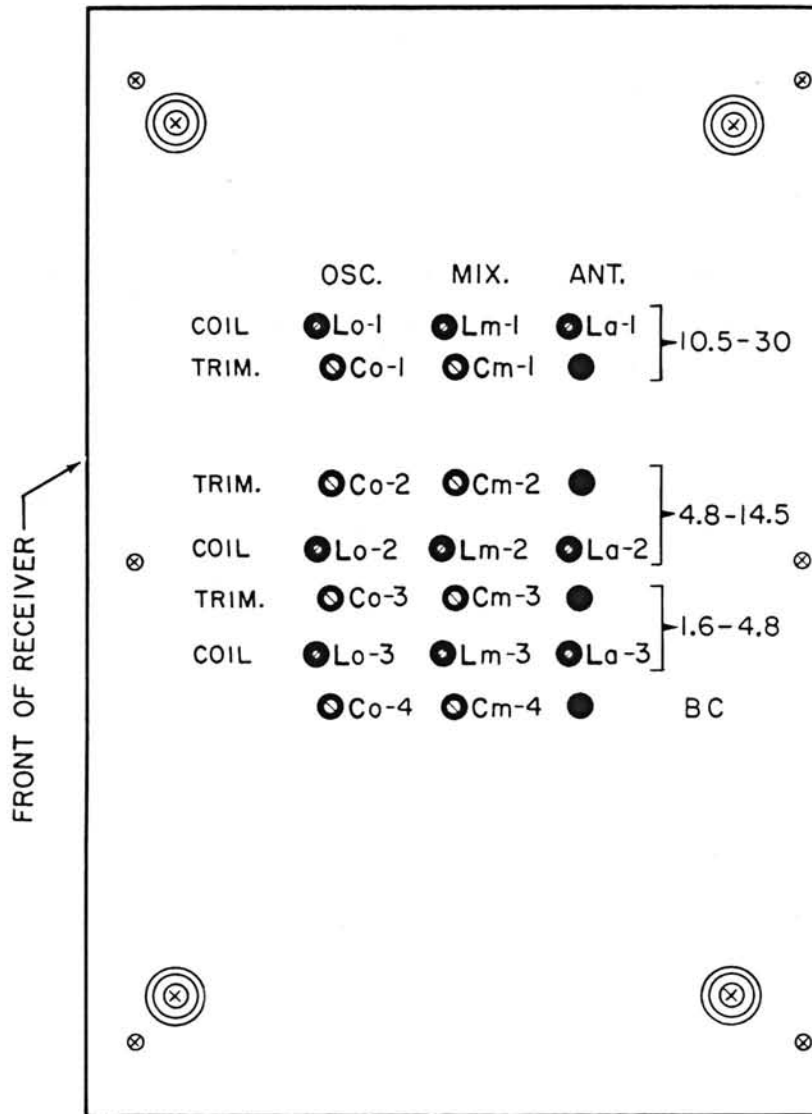

FIGURE B LOCATION OF RF ADJUSTMENTS

INSTALLATION

POWER SOURCE

The receiver is designed to operate from a 90-125 volt, 50-60 cycle AC power source. DO NOT OPERATE FROM A DC SOURCE. The receiver is equipped with a voltage selector switch (located within the unit). This switch should normally be left in the 117V position.

SPEAKER CONNECTION

A three-terminal strip marked OUTPUT is provided at the rear of the receiver for speaker connections. Any PM speaker with either 4 or 8 ohm impedance can be used. Simply connect one lead to the ground terminal "O" and the other lead to the terminal that corresponds to the speaker impedance. The output power of the receiver is sufficient to drive a 4 - 12 inch PM speaker adequately.

HEADPHONES

A standard phone jack is provided on the front panel of the receiver for headphone reception. Low impedance (8-16 ohms) headphones are recommended for optimum results. Insertion of a phone plug into the jack automatically disconnects any speaker attached to the 8 ohm output terminal.

ANTENNAS

The terminals marked "A1", "A2", and "E" at the rear of the receiver are for antenna and ground connections. Either of the following two types of connections can be used to obtain satisfactory results.

INVERTED L ANTENNA

The inverted L type of antenna will provide satisfactory performance over the entire tuning range. Simply short A2 and E with a jumper wire, and connect one end of the antenna wire to A1. For good reception, the antenna wire should be placed as high as possible and 50-100 feet long (see Fig. 1). In some instances, a wire connected from terminal "E" to a water pipe may improve reception.

DOUBLET ANTENNA

A doublet antenna will give excellent results, especially on amateur bands. A 75 ohms balanced transmission line should be used (as shown in Fig. 2). Since the doublet antenna provides optimum performance only at a given frequency, it should be cut to the length for the most often used band of frequencies. The overall length of a doublet antenna can be determined by using the following formula:

$$L \text{ (Length in feet)} = \frac{468}{\text{Frequency in megacycles}}$$

Since the doublet antenna displays directional properties broadside to its length, it should be oriented in such a manner that maximum signal pickup can be realized.

When using either a balanced transmission line or a twisted pair, the leads connect to terminals "A1" and "A2" respectively, and the jumper wire between "A2" and "E" is removed. A height of 30-50 feet is recommended for good reception of weak signals.

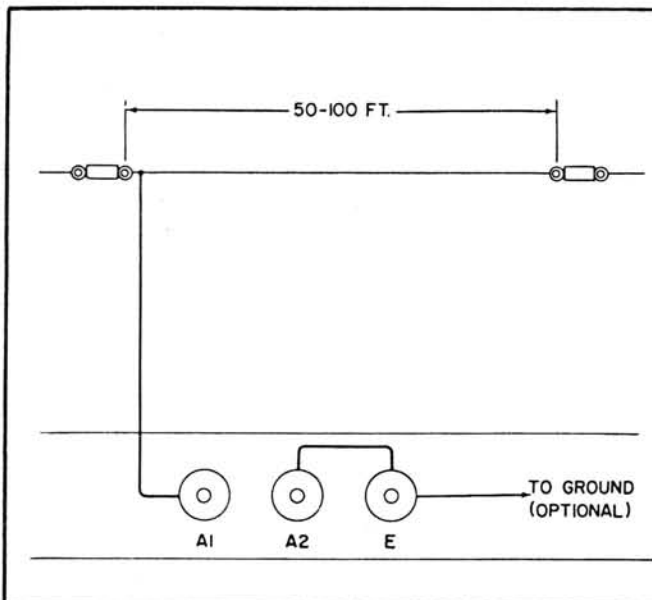

FIGURE 1

Single Wire Antenna (Inverted L)

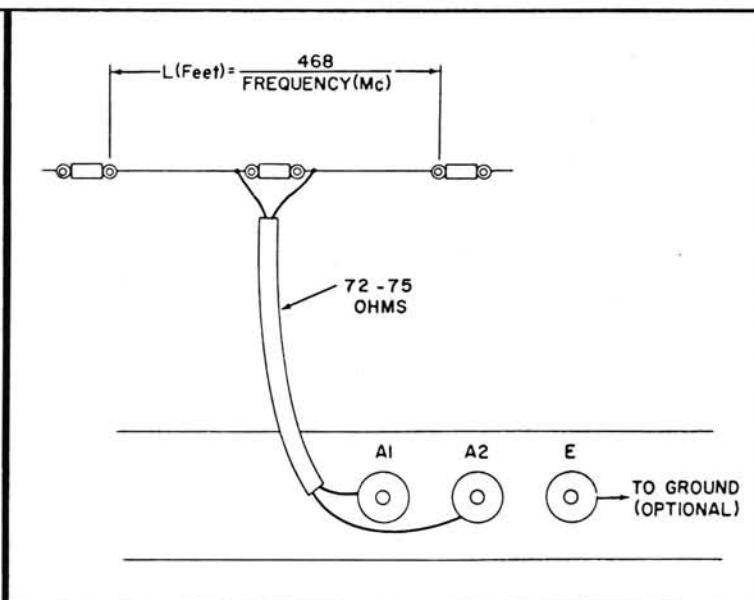

FIGURE 2

Doublet Antenna

FUSE

A 1 amp fuse is located at the rear of the receiver. To remove it, unscrew the spring loaded cap. Replace only with one of a similar rating.

AUXILIARY CONTROL

A socket in the back of the receiver allows simultaneous control of this receiver with a transmitter. An external switching device can be constructed so that the receiver will be inoperative during periods of transmission. In this case, the FUNCTION switch is placed in the SEND position. The external switch is attached to the 5-pin plug so that pins 3 and 2 (see Fig. 3) will be connected when signal reception is desired. This plug is then inserted into the socket in place of the jumper plug. In this manner, signal reception will be instantaneous, as plate voltage will be applied to the RF stages when the switch is closed accordingly.

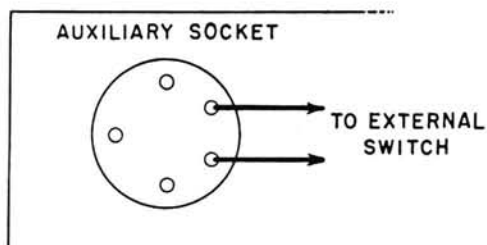

FIGURE 3

Auxiliary Control Socket

For normal operating conditions with no external switching, the jumper plug provided must be inserted into the socket. Pins 3 and 2 of the plug are shorted, thus providing plate voltage to the RF stages. To disable the receiver under these conditions, set the FUNCTION switch to the SEND position. In this position plate voltages to the RF stages are cut off. Returning the switch to REC AM will provide instantaneous signal reception

THE Q-MULTIPLIER CIRCUIT

A Q-Multiplier provides the additional selectivity often required for optimum reception of signals in the congested short-wave bands. In your receiver, the Q-Multiplier circuit serves a dual function - Q-Multiplier and BFO. For CW and SSB reception, the circuit is employed as a BFO. The circuit may be employed as a Q-Multiplier during phone reception if conditions require the use of additional selectivity.

A little experience in using the Q-Multiplier will be necessary for optimum results under different receiving conditions. In the hands of an experienced operator, the Q-Multiplier is a very handy tool, and will greatly enhance the performance of the receiver.

The controls associated with the Q-Multiplier circuit are the SELECTIVITY and BFO-Q-MULT FREQUENCY controls. They are not operative unless the Function switch is in the Q-MULT position.

SELECTIVITY CONTROL

When the control is placed in the AM-CW-SSB position, the circuit oscillates, thus providing the beat signal necessary for CW or SSB reception. Off the CW-SSB position, the circuit is connected to the IF stage and now acts as a narrow gate through which the IF signals must pass. The width of the "gate" is determined by the position of the SELECTIVITY control. Advancing the control from the fully counter-clockwise position serves to peak the signal increasingly until a point of oscillation is reached. Sharpest selectivity is reached just prior to oscillation.

BFO-Q-MULT FREQUENCY CONTROL

The action of this control is determined by the position of the SELECTIVITY control. When the Selectivity control is set to AM-CW-SSB, the BFO-Q-MULT FREQUENCY control is used to vary pitch for CW reception or to provide clarity of signal for SSB reception.

When the Selectivity control is used to increase selectivity during Q-Multiplier operation, (as described previously), the sharp peak produced can be moved around within the IF pass band by means of the BFO-Q-MULT FREQUENCY CONTROL to reduce or eliminate interference from adjacent signals.

USING THE CIRCUIT AS A Q-MULTIPLIER

Initially, all controls on the receiver should be set to the positions indicated in the chart for AM settings. Tune in desired station. Set SELECTIVITY to the fully counter-clockwise position and FUNCTION to "Q-Mult". Increase AF gain if necessary. Advance the SELECTIVITY control until the desired degree of selectivity is obtained. The point of maximum selectivity is reached just before the circuit breaks into oscillation. The BFO-Q-MULT FREQUENCY control may now be adjusted to provide a reduction, or to eliminate, any adjacent channel interference.

USING THE CIRCUIT AS A BFO

Initially, all controls should be set as indicated in the chart for CW or SSB operation. Under these conditions the BFO-Q-MULT FREQUENCY control is used to vary the pitch (CW) or for clarity of signal (SSB). The SELECTIVITY control remains permanently in the AM-CW-SSB position for CW or SSB reception.

INITIAL CONTROL SETTINGS

CONTROL	AM SETTINGS	CW SETTINGS	SSB SETTINGS
FUNCTION	REC AM	Q-MULT	Q-MULT
BAND SEL	Set for desired range	Set for desired range	Set for desired range
SELECTIVITY	AM-CW-SSB*	AM-CW-SSB	AM-CW-SSB
BFO-Q-MULT FREQUENCY	Mid-position	Mid-position	Mid-position
IF GAIN	Maximum	Adjust for desired audio level	Adjust for desired audio level
ANT TRIM	12 o'clock position	12 o'clock position	12 o'clock position
MVC-AVC	AVC	MVC	MVC
ANL OFF-ON	Optional	Optional	OFF
BANDSPREAD	Set to 100 on Logging Scale	Set to 100 on Logging Scale	Set to 100 on Logging Scale
AF GAIN	Adjust for desired audio level	2/3 to 3/4 clockwise	2/3 to 3/4 clockwise

* Setting the SELECTIVITY control to AM-CW-SSB with the FUNCTION switch in REC AM disconnects the Q-Multiplier from the IF, allowing normal IF band pass.

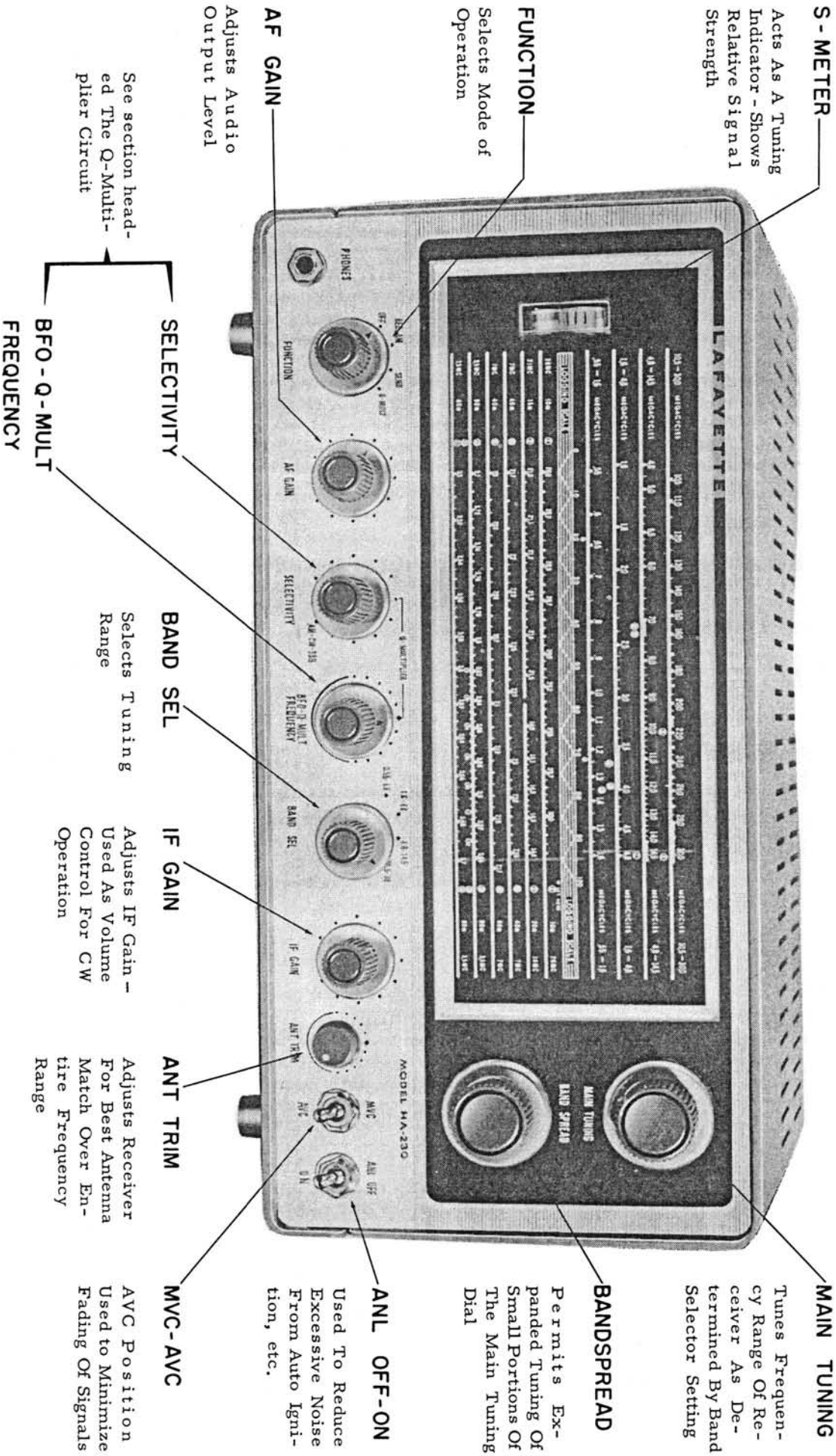

LOCATION AND FUNCTION OF CONTROLS

TUNING

The main tuning and bandspread dials are calibrated in megacycles and contain special markings to simplify tuning. The major amateur radio bands are contained in the 1.6 to 4.8, 4.8 to 14.5 and 10.5 to 30.00 megacycle bands. The location of each amateur band is indicated by heavy white scale lines on the main tuning dial. The circled letter or letters which appear with each band indicate the bandspread scale to be used. Calibration of the main tuning scales is correct when the bandspread pointer is set at 100 on the LOGGING SCALE.

Bandspreading on the amateur bands is carried out in the following manner: Set the bandspread pointer initially to 100 and the main tuning pointer directly over the circled letter for the band to be tuned. In some cases the band is split between two such letters. For example, B1 and B2 together cover the range of 7.0 to 7.35 megacycles - B1 from 7.0 to 7.17, B2 from 7.17 to 7.35 megacycles. The calibrated bandspread scale which is used is indicated to the right and left-hand side. Thus, if the main tuning pointer is set over B1, the bandspread scale in use is the one marked B1, the fourth one down. Tuning is then accomplished solely with the BANDSPREAD control.

Short-wave bandspreading, for other than amateur bands, is accomplished by setting the bandspread pointer at 100 on the Logging Scale and the main tuning pointer at the high end of the short-wave band to be tuned. Rotate the bandspread control to tune over the band. Moving the bandspread pointer towards 0 on the logging scale subtracts from the frequency indicated on the main tuning scale. Logging of short-wave stations is possible by noting the readings on both the Main Tuning and Logging Scales.

S - METER READINGS

The S-Meter provides a means of measuring the relative strength of incoming AM signals. Relative readings are only correct when the IF GAIN control is fully clockwise. Measurements are read in S units from 1 to 9 and in decibels above S9 from 0 to 40 db. The circuit is disabled when the MVC/AVC switch is in the MVC position.

A ZERO ADJ control at the rear of the receiver is provided for zeroing the S-Meter electrically. This adjustment is made with the antenna disconnected, IF GAIN control at maximum and AVC on.

ANTENNA TRIMMER

The ANT TRIM control, adjustable from the front panel, acts as a compensating capacitor to permit optimum matching of the receiver to the antenna at all frequencies. Initially, the control should be set to its mid-position (the dot on the front surface of the knob at 12 o'clock position). The control should always be adjusted for maximum background noise. Each setting will be good only over a limited range of frequencies. The trimmer should therefore always be readjusted after tuning to the general area where the expected signal is to be found.

AM OPERATION

For the reception of broadcast stations, short-wave listening, etc., place all controls in the positions indicated in the Initial Control Settings chart. Tune in station, using Main and Bandspread tuning controls as indicated in the section under "TUNING". Adjust ANT TRIM for highest "S" meter reading on signal. This antenna control setting is satisfactory while operating over a limited frequency range. If excessive spurious noises such as those caused by auto ignition make reception difficult, place the ANL OFF switch to the ON position. The automatic noise limiter should be used only when necessary, since it tends to reduce the overall efficiency of the receiver.

If interference from nearby stations makes reception difficult, the Q-Multiplier may be employed to minimize or eliminate the interference. Since the use of the Q-Multiplier results in a narrower bandwidth it should only be employed when interference is severe and where maximum fidelity is not required.

CW OPERATION

The control settings required for the reception of code signals are indicated in the chart. AVC is switched off and the IF GAIN control is used as a volume control. Tune signal to zero beat. The BFO-Q-MULT FREQUENCY control should then be adjusted on either side of white dot for desired pitch.

SINGLE SIDE BAND OPERATION

The settings of controls for SSB reception is essentially the same as for CW (see chart). The BFO frequency however, is used in this case for carrier reinsertion. AVC is switched off and the IF GAIN control used to adjust the level. Tune station in with BANDSPREAD control and then adjust BFO-Q-MULT FREQUENCY control for clarity of speech. Slight readjustment of the BANDSPREAD may be necessary to provide best audio quality.

SHORT-WAVE LISTENING

On the short-wave frequencies are to be found radio stations transmitting from all over the world. Many of these stations provide English-language broadcasts. The frequencies on which the majority of short-wave broadcast stations operate are found in the two upper bands of your receiver (4.8 to 14.5 megacycles and 10.5 to 30 megacycles). A characteristic of short-wave is that reception varies with the time of day, the season of the year and with weather conditions. In order to know just when and where to listen, a listening chart which lists English language broadcast stations best heard in North America is included in this manual. "Better Shortwave Reception" by William I. Orr (available from Lafayette under stock #10-5006) is recommended to the short-wave listener and amateur alike. It provides an introduction to short-wave radio for the beginner and presents some of the practical aspects and helpful advice for the more experienced listener.

CIRCUIT THEORY

ANTENNA STAGE

The RF amplifier V1 provides the necessary gain and preselection required for high sensitivity and rejection of image frequencies. Individual antenna input coils are used for either a balanced or unbalanced input (depending on method of antenna connection).

The ANT TRIM control, adjustable from the front panel, acts as a compensating capacitor to permit matching of the input circuits to any antenna.

MIXER STAGE

The use of a separate high-frequency oscillator, V3, results in a more stable receiver, particularly at the higher frequencies. The output signal from V1 is electronically mixed with the output of V3 in the mixer tube V2. V3 provides a signal 455 KC higher than the incoming signal on all frequency ranges. Because current is applied to the filaments of V2 and V3 at all times (even with receiver switched off), no frequency drift is experienced at any time during the operation of this receiver and a high degree of stability is therefore assured from the moment the unit is switched on.

Q-MULTIPLIER AND BFO

The Q-Multiplier circuit (V4) serves as both BFO and Q-Multiplier in this receiver. Used as a BFO for CW and SSB operation, the circuit, which acts as an oscillator, is coupled to the IF stage (via stray coupling) and provides the signal necessary for producing a beat note, or for carrier reinsertion during SSB operation. When the SELECTIVITY control, comprising R26 and S4, is in the AM-CW-SSB position during this operation, R26 is in its maximum position. The frequency of the signal is varied by means of C31, the BFO-Q-MULT FREQUENCY control. This adjusts the pitch during CW operation or clarity of speech during SSB operation. For Q-Multiplier operation, S4 is switched away from the AM-CW-SSB position, thus connecting the circuit directly to the IF stage through a coupling capacitor C9. The circuit serves as a positive feedback device having a highly selective tuned circuit which acts as a narrow "gate" for IF frequencies. The width of this gate is adjusted by means of R26 which controls the gain of V4. The resultant narrow peak can be moved around in the IF pass-band by adjustment of C31. The selectivity thus becomes adjustable and, in addition, the portion of the signal which contains the least amount of adjacent signal interference can be selected.

IF STAGES

Two stages of IF amplification, V5 and V6, provide sufficient gain and selectivity for good performance. For maximum selectivity, double-tuned transformers, T2, T3 and T4, are used for interstage coupling. High-Q permeability-tuned transformers improve performance and add to ease of tuning. R24 varies the gain of V5 and V6 and therefore acts as the IF GAIN control.

The S-meter is placed in the circuit in such a manner that readings increase with signal strength. R28, the ZERO ADJ control, is adjusted for zero current through the meter with no signal input. The S-meter is only accurate when the IF gain control is at maximum, nor does the meter function properly when AVC is off.

DETECTOR, AVC, ANL, 1st AUDIO

One diode of V7 (pin 5) serves as both detector and AVC rectifier. The rectified AVC voltage is applied to RF stage V1 and IF stage V5 to keep the output level of the receiver constant regardless of input signal variations. In the MVC position of S6, the AVC is grounded and is not in operation. The other diode (pin 6) acts as an automatic noise limiter by cutting noise peaks (caused by auto ignition, etc.) during reception. Since this causes a slight reduction in fidelity, the circuit should only be used when necessary.

The rectified signal from the detector is fed to the grid of the triode section of V7 which acts as the 1st audio amplifier. Audio level is adjusted by means of R25, the AF GAIN control.

AUDIO AMPLIFIER

V8 is employed in a conventional resistance-coupled audio amplifier which is connected to output transformer T5. Taps are provided on the secondary of the transformer for 4 or 8 ohm speakers. A standard phone jack, accessible from the front panel, permits the use of low impedance headphones when desired. Insertion of a plug in the jack automatically disconnects any speaker connected to the 8 ohm tap.

RECTIFIER

V9 functions as a full-wave rectifier in a conventional power supply circuit. C26, R23 and C27 provide the necessary filtering. The primary of the AC power transformer is fused for safety. The tapped primary also permits the use of the receiver on low AC voltages (less than 100), voltage selection being effected by S3. In most cases however, the switch should be left in the 117V position. A separate 6 volt filament transformer is employed for V2 (mixer) and V3 (oscillator). The AC power to the primary of this transformer is not switched and thus continuously supplies filament voltage to V2 and V3 even with the receiver switched off, maintaining these tubes at a proper operating temperature. This arrangement ensures stable drift-free operation as soon as the receiver is turned on. The current drawn by these tubes is negligible.

FUNCTION SWITCH

This switch determines the mode of operation. In all positions except OFF, AC power is applied to the primary of T1, thus powering the receiver. In REC AM, DC plate voltage is applied (through the external jumper plug and the switch) to V1, V2 and V3. All other tubes (except V4) receive DC plate voltage direct from the power supply. In the SEND position, plate voltage to V1, V2 and V3 is cut off. In the Q-MULT position, plate voltage is also applied to V4, in addition to all other tubes.

- RF V1 6BA6
- MIX V2 6BE6
- OMULT/BFO V4 6AV6
- IF1 V5 6BA6
- IF2 V6 6BA6
- DET. AF. ANL V7 6AV6
- PA V8 6AQ6

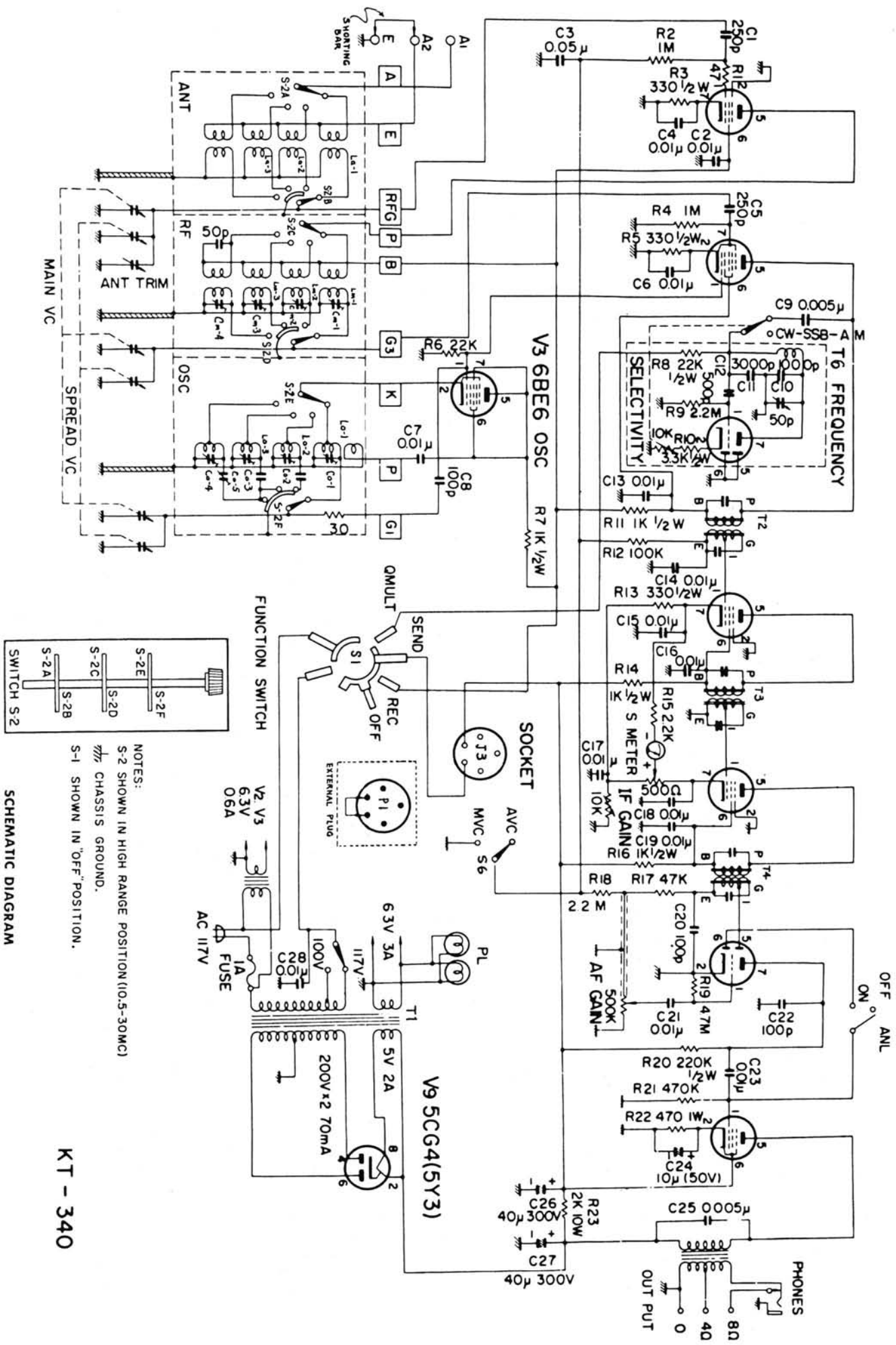

NOTES:
 S-2 SHOWN IN HIGH RANGE POSITION (10.5-30MC)
 CHASSIS GROUND.
 S-1 SHOWN IN "OFF" POSITION.

SCHEMATIC DIAGRAM

KT - 340

DIAL CORD STRINGING

Set main or bandspread tuning capacitor as indicated. In both cases, tie dial cord to spring at the START point, leaving approximately 4 inches of cord free at this point. Restring in the direction indicated, keeping a moderate amount of tension on the cord. Make final tie to free end of cord from spring after cutting off any excess cord.

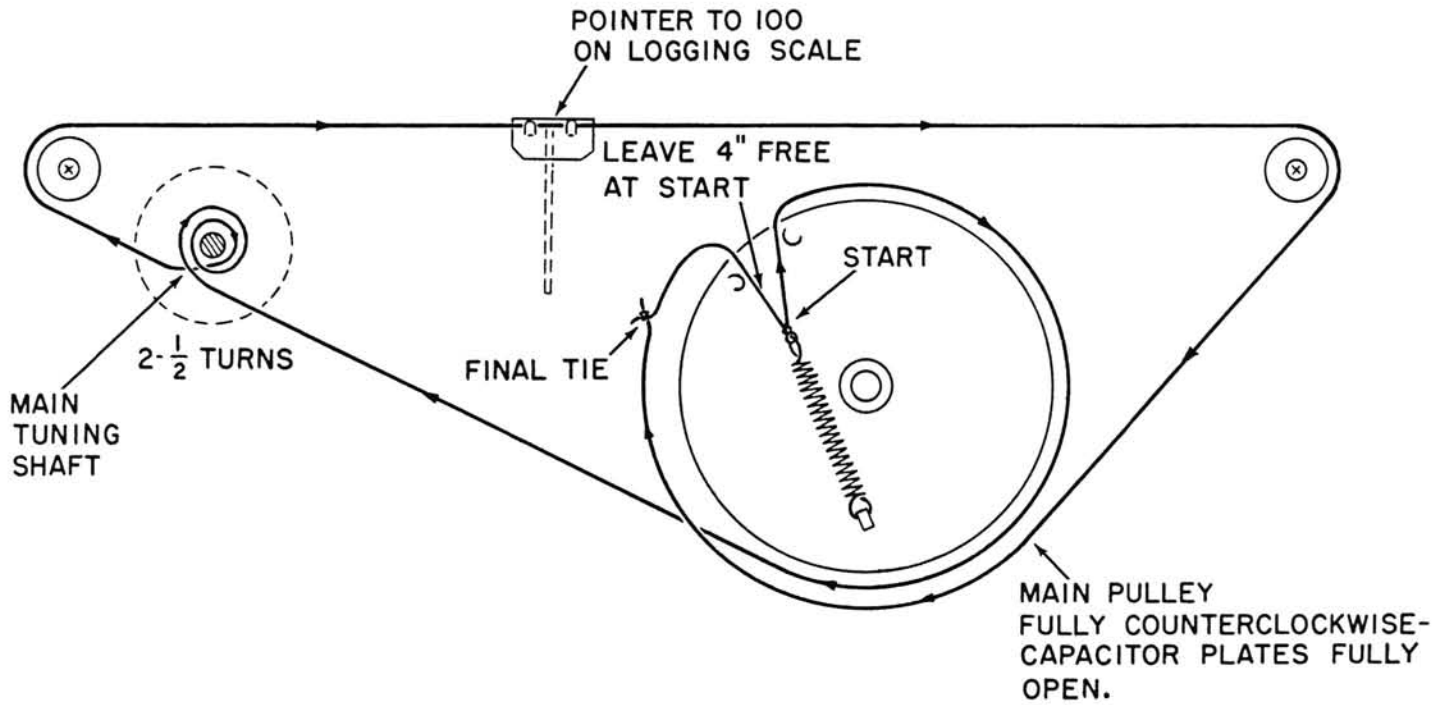

MAIN TUNING DIAL CORD STRINGING

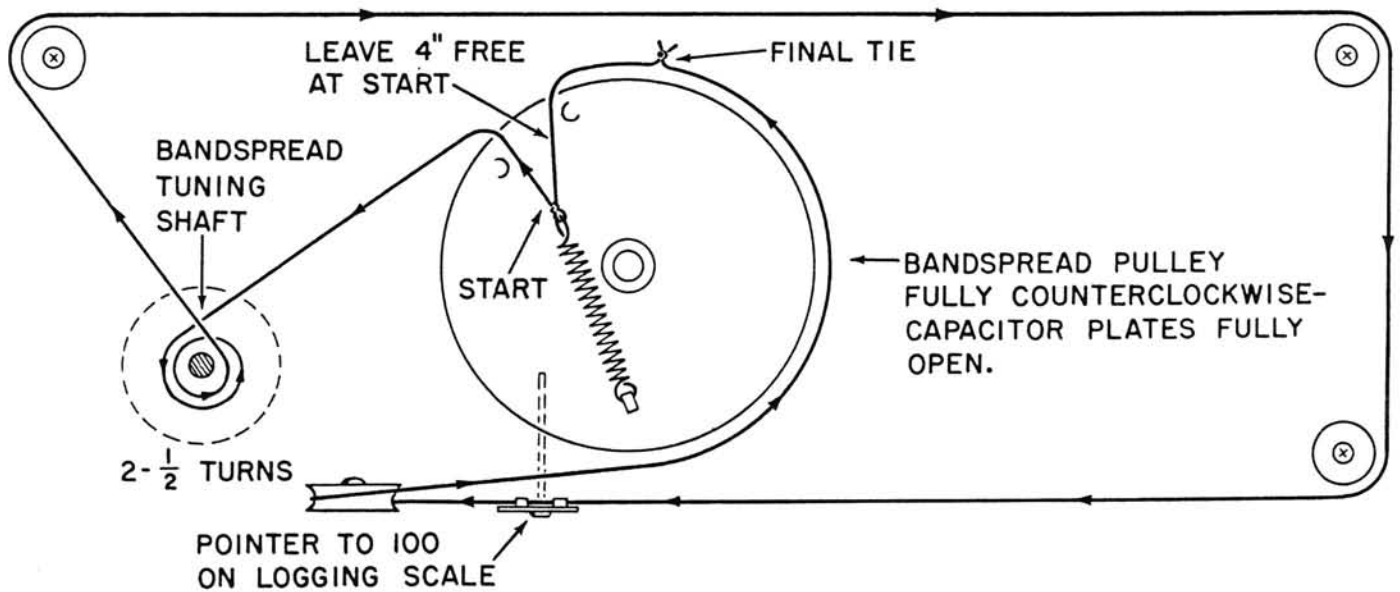

BANDSPREAD DIAL CORD STRINGING

SERVICING

In the event that your checks do not enable you to correct the defect, you may, if you wish, take advantage of Lafayette's technical consultation service which is available to you without charge. The technical consultants are thoroughly familiar with every kit, but in order for them to help you to correctly diagnose the trouble it is important that you provide as much information as possible. Details that you should include in any correspondence are:-

- a) Kit description and model number.
- b) Date purchased.
- c) A detailed description of the trouble encountered.
- d) Any checks that have been made and their results, (for example - did you check the wiring against the pictorials and instructions? Did you take voltage measurements?)

All correspondence should be addressed to:-

KIT ADJUSTMENT DIVISION
LAFAYETTE RADIO ELECTRONICS CORP.
111 JERICHO TURNPIKE SYOSSET, L. I., N. Y.

If you are not familiar enough with electronics to provide the information required for correct diagnosis, or in the event that you prefer to have the difficulty corrected at our factory, the unit may be returned to us for repair or adjustment. We will undertake to put it into proper operating condition subject to the following charges and conditions.

1. All repair work will be carried out at the rate of \$4.00 per hour. No charge will be made for parts found defective under the replacement warranty.
2. A charge will be made for replacement parts not covered by the warranty, in addition to the labor charges.
3. The charge for complete alignment of the receiver is \$9.50.

Kits which were not wired in accordance with our detailed instructions, or kits wired with acid solder or paste flux are not eligible for service and will be returned to you at your expense. Kits not completed which require extensive work will also be returned collect with a letter of explanation.

SHIPPING INSTRUCTIONS

If the kit must be returned for service, attach a tag to the unit bearing your name, complete address and a brief description of the difficulties encountered.

Wrap the unit in heavy paper before placing into the carton which should be large enough to permit the use of at least three inches of shredded paper or excelsior between all sides of the unit and the carton. Mark the carton FRAGILE and clearly address it as follows:-

TO:

Kit Adjustment Division
LAFAYETTE RADIO ELECTRONICS CORP.
111 JERICHO TURNPIKE SYOSSET, L. I., N. Y.

Include your own name and address on the carton and ship by prepaid express. The unit will be returned to you express collect. Bear in mind that the carrier will disclaim responsibility for damage if, in his opinion, it was caused by improper packing.

Listen to the Voices of the World

ENGLISH LANGUAGE SHORT-WAVE BROADCAST STATIONS BEST HEARD IN WESTERN NORTH AMERICA

Readers in the western part of the United States and Canada will find the following list of "Best Heard" stations helpful in tuning the short-wave broadcast bands. The left-hand column lists the hour in Pacific Standard Time for broadcasts in English only; in the middle column, the city and country from which the broadcasts originate are listed with the name the station uses for identification in parentheses; and on the right are the frequencies and call letters for stations using them during their broadcasts.

TIME (PST)	CITY, COUNTRY (NAME)	FREQUENCIES (kc.)
6:00-8:00 a.m.	Manila, Philippines (<i>The Call of the Orient!</i>)	11855, 9730
6:30-7:30 a.m.	Djakarta, Indonesia (<i>The Voice of Indonesia</i>)	9710, 4910
7:15-8:15 a.m.	Bombay, India (<i>The Voice of India</i>)	11770 (VLC11)
8:00-8:15 a.m.	Stockholm, Sweden (<i>Radio Sweden</i>)	15155
10:00-11:00 p.m.	London, England (<i>General Overseas Service</i>)	17700
1:30-2:15 p.m.	London, England (<i>General Overseas Service</i>)	15310, 15310
2:15-3:15 p.m.	London, England (<i>General Overseas Service</i>)	17825 (JOA27)
3:00-3:30 p.m.	Tokyo, Japan (<i>Radio Japan</i>)	15235 (JOB9)
3:00-7:00 p.m.	London, England (<i>General Overseas Service</i>)	11930, 9825
3:00-10:00 p.m.	Moscow, USSR (<i>Radio Moscow</i>)	17865, 15140
4:30-4:50 p.m.	Tokyo, Japan (<i>Radio Japan</i>)	15235 (JOB9)
4:55-5:45 p.m.	Montreal, Canada (<i>Radio Canada</i>)	11705 (JOA4)
5:00-7:30 p.m.	Cape Haitien, Haiti (<i>The Evangelistic Voice</i>) — no broadcasts on Wednesday and Thursday	15190 (CKCX)
5:30-7:15 p.m.	Berne, Switzerland (<i>Switzerland Calling</i>)	11720 (CHOL)
6:00-9:00 p.m.	Quito, Ecuador (HCJB — <i>The Voice of the Andes</i>) — no broadcast on Monday	15400, 9656
6:35-6:45 p.m.	Rome, Italy (<i>Italian Broadcasting & TV System</i>)	11865 (HER5), 9535 (HER4), 6165 (HER3)
6:30-6:40 p.m.	Cologne, Germany (<i>The Voice of Germany</i>)	15115, 11915, 9745
6:30-7:00 p.m.	Warsaw, Poland (<i>Radio Warsaw</i>)	9575, 6010
6:30-7:10 p.m.	Hilversum, Holland (<i>Radio Netherlands</i>)	11795, 9640
6:30-8:00 p.m.	Hilversum, Holland (<i>The Happy Station</i>) — special program on Sundays only	9625, 6025
6:45-7:00 p.m.	Brazzaville, FEA (<i>Radio Brazzaville, French Equatorial Africa</i>)	11950, 9590
6:55-7:35 p.m.	Montreal, Canada (<i>Radio Canada</i>)	11970, 9625
7:00-7:30 p.m.	Bucharest, Romania (<i>Bucharest Calling</i>)	11945 (CKNK), 9585 (CKLP)
7:00-7:30 p.m.	Peking, China (<i>Radio Peking</i>)	11937, 9570
7:00-8:30 p.m.	Prague, Czechoslovakia (<i>Radio Prague</i>)	17745, 17720, 15350, 15118
7:00-8:45 p.m.	Guatemala City, Guatemala (TGNA)	6105, 6055
7:15-8:00 p.m.	Madrid, Spain (<i>The Voice of Spain</i>)	9668, 5952
7:30-8:00 p.m.	Copenhagen, Denmark (<i>The Voice of Denmark</i>) — no English on Sundays	9360, 6130
7:30-8:00 p.m.	Tokyo, Japan (<i>Radio Japan</i>)	9520 (OZE), 15205 (ORB9)
8:00-8:20 p.m.	Oslø, Norway (<i>Radio Norway</i>) — on Sundays only	15170 (JOA4)
8:00-8:30 p.m.	Budapest, Hungary (<i>Radio Budapest</i>)	15175, 1735, 9540
8:00-8:30 p.m.	Sofia, Bulgaria (<i>Sofia Calling</i>)	11910, 9833
8:00-9:00 p.m.	San Jose, Costa Rica (TIFC — <i>The Lighthouse of the Caribbean</i>)	9700
8:15-9:00 p.m.	Berne, Switzerland (<i>Switzerland Calling</i>)	9647, 6037
8:15-9:00 p.m.	Madrid, Spain (<i>The Voice of Spain</i>)	11865 (HER5), 9535 (HER4)
8:30-9:00 p.m.	Bucharest, Romania (<i>Bucharest Calling</i>)	9360, 6130
9:00-9:30 p.m.	Taipei, Taiwan (<i>The Voice of Free China</i>)	11937, 9570
9:00-9:30 p.m.	Stockholm, Sweden (<i>Radio Sweden</i>)	15225, 11815
9:15-9:30 p.m.	Brazzaville, FEA (<i>Radio Brazzaville, French Equatorial Africa</i>)	9620
9:15-10:00 p.m.	Madrid, Spain (<i>The Voice of Spain</i>)	11970
9:30-10:00 p.m.	Warsaw, Poland (<i>Radio Warsaw</i>)	9360, 6130
10:30-11:00 p.m.	Taipei, Taiwan (<i>The Voice of Free China</i>)	9525, 6025

REPRINTED FROM POPULAR ELECTRONICS BY PERMISSION

TIME (PST)	CITY, COUNTRY (NAME)	FREQUENCIES (kc.)
10:30-2:45 a.m.	Wellington, New Zealand (<i>Radio New Zealand</i>)	9540 (ZL2), 6080 (ZL7)
11:30-11:45 p.m.	Papeete, Tahiti (<i>The Voice of France in the Pacific</i>)	6135
12:00-1:15 a.m.	Manila, Philippines (<i>Call of the Orient</i>)	17805, 15300, 11855, 9730

NEWS BROADCASTS FOR WESTERN NORTH AMERICA

The following listing of news broadcasts has been prepared for those readers living in the Western United States and Canada. Times are given in Pacific Standard Time and the frequencies in kilocycles.

TIME (PST)	CITY AND COUNTRY	FREQUENCIES (kc.)
6:45 a.m.	Djakarta, Indonesia	9710, 4910
7:30 a.m.	Manila, Philippines	11855, 9730
7:30 a.m.	Melbourne, Australia	11770
8:00 a.m.	Stockholm, Sweden	15155
9:00 a.m.	London, England	17700
12:00 Noon	London, England	17700
3:00 p.m.	Tokyo, Japan	15310, 11930, 9825
3:00 p.m.	Moscow, USSR	17825, 15235
3:00 p.m.	Moscow, USSR	17865, 15140
4:00 p.m.	Moscow, USSR	17865, 15140
4:30 p.m.	Delhi, India	17720, 15160
4:30 p.m.	Tokyo, Japan	15235, 11705
5:00 p.m.	Montreal, Canada	15190, 11720
5:00 p.m.	Moscow, USSR	17865, 15140
5:00 p.m.	Karachi, Pakistan	17750, 15335
5:30 p.m.	Montreal, Canada	15190, 11720
5:35 p.m.	Berne, Switzerland	11865, 9535, 6185
6:00 p.m.	London, England	11930, 9825
6:00 p.m.	Moscow, USSR	17865, 15140
6:25 p.m.	Rome, Italy	9575, 6010
6:30 p.m.	Cologne, Germany	11795, 9640
6:30 p.m.	Warsaw, Poland	9525, 6025
6:30 p.m.	Hilversum, Holland (not on Sunday)	11950, 9590
6:30 p.m.	Delhi, India	17830, 15160, 11710
6:45 p.m.	Brazzaville, French Equatorial Africa	11970, 9625
7:00 p.m.	Moscow, USSR	17865, 15140
7:00 p.m.	Montreal, Canada	11937, 9570
7:00 p.m.	Bucharest, Romania	11945, 9585
7:00 p.m.	Peking, China	17745, 17720, 15350, 15118
7:00 p.m.	Prague, Czechoslovakia	9668, 5952
7:15 p.m.	Madrid, Spain	9360, 6130
7:30 p.m.	Copenhagen, Denmark (only Mondays)	9520, 11705
7:30 p.m.	Tokyo, Japan	15235, 11705
8:00 p.m.	Moscow, USSR	17825, 15140
8:00 p.m.	Oslø, Norway (only Sundays)	15175, 1735, 9540
8:00 p.m.	Sofia, Bulgaria	9700, 11735, 9540
8:15 p.m.	Madrid, Spain	9360, 6130
8:30 p.m.	Bucharest, Romania	11845, 9535
8:30 p.m.	Berlin, Germany	11837, 9570
9:00 p.m.	Taipei, Taiwan	15225, 11815
9:00 p.m.	Moscow, USSR	17865, 15140
9:00 p.m.	Stockholm, Sweden	9620
9:15 p.m.	Brazzaville, French Equatorial Africa	11970
9:15 p.m.	Madrid, Spain	9360, 6130
9:30 p.m.	Warsaw, Poland	9525, 6025
9:30 p.m.	Taipei, Taiwan	15225, 11815
10:30 p.m.	Wellington, New Zealand	9540, 6080
11:30 p.m.	Papeete, Tahiti	6135
12:30 a.m.	Wellington, New Zealand (not on Sunday)	9540, 6080
1:00 a.m.	Manila, Philippines	11855, 9730
2:30 a.m.	Wellington, New Zealand	9540, 6080

ENGLISH LANGUAGE SHORT-WAVE BROADCAST STATIONS BEST HEARD IN EASTERN NORTH AMERICA

TIME (EST)	CITY, COUNTRY (NAME)	FREQUENCIES (Kc.)	TIME (EST)	CITY AND COUNTRY	FREQUENCIES (Kc.)
6:00-6:30 a.m.	Warsaw, Poland (Radio Warsaw)	17000, 15120			
7:00-7:15 a.m.	Helsinki, Finland (Finland Calling) — no English on Sundays and holidays	17798, 15190			
7:15-8:15 a.m.	Warsaw, Poland (Radio Warsaw)	17800, 15120	5:30 a.m.	Wellington, New Zealand	9540, 6080
7:15-8:45 a.m.	Melbourne, Australia (Radio Australia)	11770, (VLA11)	6:00 a.m.	Warsaw, Poland	17800, 15120
8:00-9:30 a.m.	Cape Haitien, Haiti (The Evangelistic Voice) — no broadcast on Thursdays	15399, 9638	6:15 a.m.	Djakarta, Indonesia	9710
8:15-8:45 a.m.	Stockholm, Sweden (Radio Sweden)	17840	7:00 a.m.	Helsinki, Finland	17798, 15190
10:00-12:15 p.m.	London, England (North American Service)	17700	7:15 a.m.	Warsaw, Poland	17800, 15120
1:00-4:00 p.m.	London, England (North American Service)	17700	7:45 a.m.	Melbourne, Australia	11770
4:00-5:15 p.m.	London, England (General Overseas Service)	17700, 15310, 9008	8:15 a.m.	Stockholm, Sweden	17840
4:15-4:45 p.m.	Hilversum, Holland (Radio Netherlands) — no English on Sundays	15365, 11950	8:15 a.m.	Melbourne, Australia	11770
4:30-5:30 p.m.	Jerusalem, Israel (The Voice of Zion)	9008	8:45 a.m.	Lisbon, Portugal	21495, 17895
5:00-5:30 p.m.	Port-au-Prince, Haiti (Radio Commerce) — on Sundays only	9482 (4VC)	12:00 Noon	London, England	17700
5:15-6:15 p.m.	London, England (General Overseas Service)	15310, 11930	12:15 p.m.	Athens, Greece	21700, 17895
6:00-6:30 p.m.	Tokyo, Japan (Radio Japan)	17825 (JOA22), 15235 (JOB9)	12:30 p.m.	London, England	17700
6:00-10:00 p.m.	London, England (General Overseas Service)	11930, 9825	3:00 p.m.	London, England	17700
6:00-1:00 a.m.	Moscow, USSR (Radio Moscow)	11937, 11890, 11845, 11825, 11805, 11740, 11700, 9700, 9685	3:15 p.m.	Teheran, Iran	15100
			4:15 p.m.	Damascus, Syria	17865
			4:30 p.m.	Hilversum, Holland	15365, 11950
			5:15 p.m.	Jerusalem, Israel	9008
			6:00 p.m.	Belgrade, Yugoslavia	4100
			6:00 p.m.	London, England	15310, 11930, 9825
			6:15 p.m.	Tokyo, Japan	17825, 15235
			6:15 p.m.	Moscow, USSR	11937, 11890, 11845, 11825, 11805, 11740, 11700, 9700, 9685
			6:30 p.m.	Caracas, Venezuela (Monday-Friday)	9515
6:15-7:00 p.m.	Ankara, Turkey (Radio Ankara)	9515			4970
7:15-7:35 p.m.	Rome, Italy (Italian Broadcasting and Television System)	9575, 6010			
7:30-7:50 p.m.	Tokyo, Japan (Radio Japan)	15235 (JOB9), 11705 (JOA4)			
7:30-8:00 p.m.	Budapest, Hungary (Radio Budapest)	11910, 9833			
7:30-8:00 p.m.	Prague, Czechoslovakia (Radio Prague)	9625, 6025			
7:30-8:30 p.m.	Warsaw, Poland (Radio Warsaw)	15190 (CKCX), 11720 (CHOL)			
7:55-8:45 p.m.	Montreal, Canada (Radio Canada)	9700			
8:00-8:30 p.m.	Sofia, Bulgaria (Sofia Calling)	9620			
8:00-9:30 p.m.	Stockholm, Sweden (Radio Sweden)	15400, 9656, 6105			
8:00-10:30 p.m.	Cape Haitien, Haiti (The Evangelistic Voice) — no broadcast on Wednesdays and Thursdays	11970, 9625			
8:15-9:00 p.m.	Brazzaville, French Equatorial Africa (Radio Brazzaville)	11865 (HER6), 9535 (HER4), 6165 (HER3)			
8:30-10:15 p.m.	Berne, Switzerland (Switzerland Calling)	15175, 11735, 9540			
9:00-9:30 p.m.	Oslo, Norway (Radio Norway) — on Sundays only	9520 (OZP)			
9:00-9:30 p.m.	Copenhagen, Denmark (The Voice of Denmark) — no English on Sundays	15115, 11915, 9745			
9:00-12:00 p.m.	Quito, Ecuador (HCJB — The Voice of the Andes) — no broadcasts on Mondays	9675, 6010			
9:25-9:45 p.m.	Rome, Italy (Italian Broadcasting and Television System)	11795, 9640	8:35 p.m.	Berne, Switzerland	11865, 9535, 6165
9:30-9:40 p.m.	Cologne, Germany (The Voice of Germany)	9525, 6025	9:00 p.m.	Stockholm, Sweden	9620
9:30-10:00 p.m.	Warsaw, Poland (Radio Warsaw)	11950, 9590	9:00 p.m.	Oslo, Norway	15175, 11735, 9540
9:30-10:10 p.m.	Hilversum, Holland (Radio Netherlands)	11950, 9590	9:00 p.m.	Stockholm, Sweden	9620
9:30-11:00 p.m.	Hilversum, Holland (The Happy Station) — special program on Sundays only	11950, 9590	9:25 p.m.	Moscow, USSR	11890, 11845, 11825, 11805, 11740, 11700, 9700, 9685
9:45-10:00 p.m.	Port-au-Prince, Haiti (Radio Haiti) — on Thursdays only	6192, 4VHW	9:30 p.m.	Cologne, Germany	11795, 9640
9:45-10:30 p.m.	Brazzaville, French Equatorial Africa (Radio Brazzaville)	11970, 9625	9:30 p.m.	Warsaw, Poland	9525, 6025
10:00-10:30 p.m.	Montreal, Canada (Radio Canada)	11945 (CKNK), 9585 (CKLP)	9:30 p.m.	Hilversum, Poland	11950, 9590
10:00-11:00 p.m.	Bucharest, Romania (Bucharest Calling)	11937, 9570	9:45 p.m.	Brazzaville, French Equatorial Africa (not on Sundays)	11970, 9625
10:00-11:45 p.m.	Prague, Czechoslovakia (Radio Prague)	9685, 6170, 6105, 8055	10:00 p.m.	Stockholm, Sweden	11890, 9625
10:00-11:00 p.m.	Guatemala City, Guatemala (TCNA)	9668, 5852	10:00 p.m.	Montreal, Canada	11945, 9585
10:15-11:00 p.m.	Madrid, Spain (The Voice of Spain)	9660, 6130	10:00 p.m.	Moscow, USSR	11890, 11845, 11825, 11805, 11740, 11700, 9685
10:30-11:00 p.m.	Copenhagen, Denmark (The Voice of Denmark) — no English on Sundays	9520 (OZP)	10:15 p.m.	Bucharest, Romania	11937, 9570
11:00-11:30 p.m.	Budapest, Hungary (Radio Budapest)	11910, 9833	10:30 p.m.	Madrid, Spain	9360, 6130
11:00-11:30 p.m.	Sofia, Bulgaria (Sofia Calling)	9700			9520
11:00-12:00 p.m.	San Jose, Costa Rica (TIPC — The Lighthouse of the Caribbean)	9647, 6037	11:00 p.m.	Copenhagen, Denmark (Monday only)	9700
11:15-12:00 p.m.	Berne, Switzerland (Switzerland Calling)	11865 (HER6), 9535 (HER4)	11:00 p.m.	Sofia, Bulgaria	11890, 11845, 11825, 11805, 11740, 11700
11:15-12:00 p.m.	Madrid, Spain (The Voice of Spain)	9660, 6130	11:15 p.m.	Moscow, USSR	11890, 11845, 11825, 11805, 11740, 11700
11:30-12:00 p.m.	Bucharest, Romania (Bucharest Calling)	11937, 9570	11:30 p.m.	Berne, Switzerland	11865, 9535
12:00-12:30 a.m.	Stockholm, Sweden (Radio Sweden)	9620	12:00 Midnight	Bucharest, Romania	11937, 9570
12:15-12:30 a.m.	Brazzaville, French Equatorial Africa (Radio Brazzaville)	11970	12:15 a.m.	Stockholm, Sweden	9620
12:15-1:00 a.m.	Madrid, Spain (The Voice of Spain)	9360, 6130	12:15 a.m.	Moscow, USSR	11860, 11845, 11805, 11740, 11700, 9685, 9445, 9610
12:30-1:00 a.m.	Warsaw, Poland (Radio Warsaw)	9525, 6025	12:30 a.m.	Madrid, Spain	9360, 6130
				Equatorial Africa	11970
				Warsaw, Poland	9525, 6025

NOTES

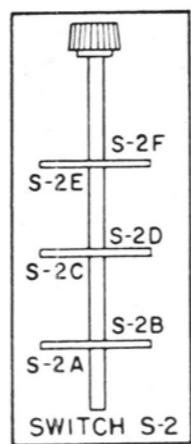
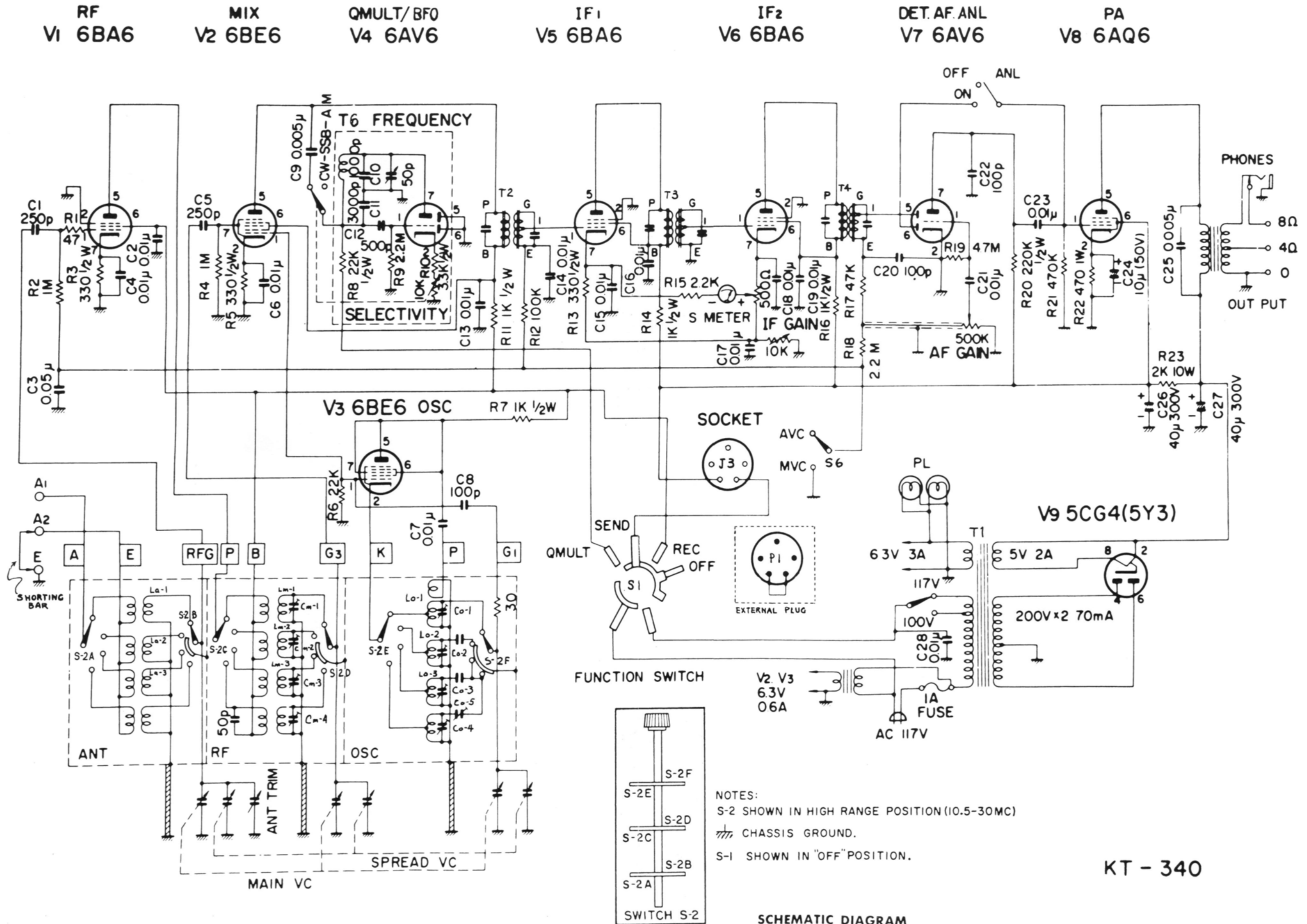

NOTES:
 S-2 SHOWN IN HIGH RANGE POSITION (10.5-30MC)
 CHASSIS GROUND.
 S-1 SHOWN IN "OFF" POSITION.

SCHEMATIC DIAGRAM

KT - 340

LAFAYETTE RADIO ELECTRONICS CORP.

111 JERICO TURNPIKE • SYOSSET, L.I., NEW YORK