

**SURPLUS RADIO
CONVERSION MANUAL**

VOLUME II

by

R. C. Evenson and O. R. Beach



Published and distributed to the electronics trade by

EDITORS and ENGINEERS, Ltd. Summerland , California

Dealers: Electronic distributors, order from us. Bookstores, libraries, newsdealers order from Baker & Taylor, Hillside, N.J. Export (exc. Canada), order from H.M. Snyder Co., 440 Park Ave. So., N.Y. 16.

Copyright 1948 by

Techno-Graphic Publications

Printed in U.S.A.

TABLE OF CONTENTS

<u>Subject</u>	<u>Page</u>
BC-454 or ARC-5 Receivers, Conversion to 28 Mc.	5
AN/APS-13 Transmitter/Receiver, to 420 Mc.	13
BC-457 or ARC-5 Transmitters, Conversion to 28 Mc.	21
Selenium-Rect. Selenium-Rectifier Power Units	32
ARC-5 VHF Transmitter/Receiver, Operation.	36
GO-9/TBW Transmitter, Conversion incl. 28 Mc.	44
BC-357 Marker Receiver, to Capacity Relay.	53
BC-946B Receiver, to High-Fidelity Tuner	56
BC-375 Transmitter, Use with Ext. V.F.O.	67
TA-12B Transmitter, Conversion, also TA-12C	74
AN/ART-13 Transmitter, to A-C power and 28 Mc.	84
Coil Data Simplified Winding Charts	92
AVT-112A Transmitter for Light Aircraft	95
AM-26/AIC Interphone Amplifier, to 9-Watt Amp.	102
LM Frequency Meter	108
Rotators Surplus Beam Rotating Mechanisms.	115
Power Chart Primary Power Requirements Chart	121
ARB Receiver, Diagram Only	124

Acknowledgment gratefully is given to the Editors of CQ, to the Editors of QST, to the students and instructors of Electronic Technical Institute of Los Angeles, and to the Vickers Electric Division of the Sperry Corporation for information, illustrations, and suggestions which have been incorporated into this volume.

CONVERTING THE ARC-5 AND BC-454 SERIES RECEIVERS FOR OPERATION ON 10 METERS

The ARC-5 and BC-454 "Command Set" series receivers may be converted into 10-meter receivers that are hard to beat. They are especially well adapted for mobile use. One of these receivers can be used in conjunction with the ARC-5 transmitter on 10 meters, as described elsewhere in this manual, to make up a very economical mobile installation.

(a) General Description:

The receivers are very compact, light, and completely enclosed in an aluminum case. The basic circuit is that of a 6-tube superhet designed to obtain its "B" voltage from a 28-volt dynamotor normally clipped onto the rear of the chassis. (For additional data and other uses for these units, see Volume I of this manual.)

All units of the series are nearly identical with the exception of frequency coverage and intermediate frequencies, which are given in the following chart:

Navy	Army	Freq. Coverage	IF Freq.
	BC-453	190-550 kc.	85 kc.
	BC-946B	520-1500 kc.	239 kc.
R26/ARC5	BC-454	3-6 Mc.	1415 kc.
R27/ARC5	BC-455	6-9 Mc.	2830 kc.

The first two receivers listed are not recommended for 10-meter operation due to the low intermediate frequency.

The following instructions are applicable to all models. However, if the ARC-5 series is used special attention should be paid to the following points. The ARC-5 receivers differ from the BC-454 series in that they use a 12SF7 tube at V6 as the second IF and AVC, whereas the command sets use a 12SK7 as second IF and the AVC is taken from the 12SR7 stage. This causes some change in the audio circuit components, due to the different AVC circuits. A diagram (Fig. 3) is given of the ARC-5 after conversion.

(b) Filament Circuit Changes:

As the filaments were originally wired for 28-volt operation (in series parallel) it will be necessary to rewire them for 6-volt operation by placing all tubes in parallel with one side common to ground. The hot filament lead may be brought out on pin 6 of the rear plug. (Wires on this pin were part of the original filament circuit and may be removed.) All extra filament wiring as used in the original 28-volt system should be removed, along with the filament choke L-14.

The present 12-volt tubes should be replaced with their 6-volt equivalents as follows:

Original	Replacement
12SK7	6SK7
12K8	6K8
12SR7	6SR7 or 6SQ7
12A6	6K6, 6V6 or 6F6
ARC-5 Only-12SF7	6SF7

No changes in wiring are necessary when substituting 6-volt tubes.

(c) Removal of Present CW Oscillator Stage:

It is assumed that the CW oscillator will not be desired on 10 meters. Since this stage can be made into an additional stage of audio, all wires to terminals 6 and 2 of the 12SR7 tube and all wires to terminal 5 of the 12A6 should be removed. This operation causes the following component parts to be useless. Hence they may be removed. R14, C26, L12, L13, C27, C28, R15, R18, R19, R20, R16, R17, C29. It will be necessary to refer to the original circuit (Fig. 1) to locate and remove these parts. Once again some confusion may arise if the ARC-5 is being converted, so be careful to remove only the parts associated with the CW oscillator circuit.

(d) Addition of First Audio Stage:

The operation just accomplished causes the triode section of the 12SR7 tube to be free for use as a stage of resistance-coupled amplification. Refer to the circuit of Fig. 2 if the BC-454 series is used and to Fig. 3 if the ARC-5 is used.

The audio volume control included in the revision is mounted on the front panel in place of the original adapter plug, from which all wiring can be removed. However, the wire labeled "Gain Control Line" on the circuit diagram normally went through an external 50,000-ohm pot to ground for control of RF gain. In this conversion it is to be grounded directly to the chassis at some convenient point, allowing the RF gain to run wide open.

It will be noted that a 1N34 crystal-diode noise limiter is included in the circuit. This limiter is especially advisable if the receiver is to be used in an automobile. The noise-silencer switch is mounted in place of C5. (C5 may be used in the plate circuit of V7 after conversion.)

The present output transformer should be replaced, as the original one was designed to match headphones and will not match the ordinary PM speaker. A small universal matching transformer to couple the chosen output tube to a PM speaker should be installed.

(e) Antenna Post Modification:

It is advisable to remove the present antenna post and to replace it with a standard bayonet receptacle as used on most auto radios. For convenience, it is suggested that this receptacle be installed on the side of the receiver instead of on the front.

Note: The above modifications will allow operation on the original frequency of the unit merely by applying heater and plate voltage; however, for 10-meter operation the RF section must be modified further as follows:

(f) RF Components:

Remove the plug-in RF assembly consisting of the 3 coils enclosed in the metal shield cans. Work on one coil at a time. It will be necessary to remove the metal slug in each coil to facilitate rewinding. The slug is replaced when rewinding is finished.

L1 (Ant coil) Remove the existing winding and rewind with 6 turns of No. 18 enameled wire, space wound the full length of the coil form.

L2 (Honeycomb mixer coil) Remove the existing honey-comb coil with the exception of the last layer. This will leave approximately 9 turns for L2. This should be interwound with L3 after L3 has been rewound as in the next step. (Added sensitivity will be gained by interwinding the coils.)

L3 (On same form as L2) Remove the existing winding and rewind with 5 turns of No. 18 enameled wire, space wound the full length of the coil form. (Now interwind L2 with L3.)

L4 (Osc coil - small winding) No alteration necessary.

L5 (Osc coil - on same form as L4) Remove the existing winding and rewind with 5 turns of No. 18 enameled wire close spaced. L5 should be between 1/8" and 3/16" from L4.

In order to provide sufficient spread of the 10-meter band, it is necessary to reduce the capacitance of each section of the tuning condenser. This is accomplished by pulling off all rotor plates with the exception of the slotted one at the end of each section. This can be done with a pair of long nosed pliers without removing the condenser. Using a single plate in each section of the condenser, the band spread should be about 27 to 30 Mcs on the calibrated dial. The original dial plate should be removed by loosening the retaining nut, and replaced with a round piece of lucite or metal on which the 10-meter calibration may be marked.

If not already provided, holes should be drilled in the RF section shield to expose the trimmer condensers with the shield in place. Otherwise, the added capacitance of the shield would detune the circuits.

At this point the receiver is capable of operation providing power is applied. (See following section on power supplies.) The alignment is quite simple. The receiver should operate smoothly over the band. If it does not oscillate, reverse the connections to the oscillator coil winding. If the receiver is sensitive only in spots instead of over the entire range, take a turn at a time off the oscillator coil or coils until the receiver tracks. (The oscillator must be tuned above the incoming frequency to obtain proper tracking.) Normally the oscillator can be made to track properly by adjustment of the oscillator trimmer, but sometimes a turn or so must be taken off the coil to increase its frequency.

If the RF trimmer appears to have no effect, take a turn at a time from the center coil (small wire) until the trimmer gives a definite peak in output.

The oscillator padder should be adjusted for maximum output while the tuning dial is rocked back and forth. The oscillator trimmer may be used to move the 10-meter band into the limits of the dial desired.

The 2-meg. grid resistor of V3 should be detached from the AVC circuit and grounded to give a better signal/noise ratio.

(g) Power Supplies:

A simple power supply circuit for use with the receiver is shown in Fig. 4. A vibrator supply can be used if mobile operation is desired. Also, for mobile operation the voltages can be taken from the existing broadcast receiver thus eliminating the need for an extra supply. In this case it is necessary to place a switch in the broadcast receiver to remove its load from the power supply when the 10 meter receiver is being used.

(h) Rack Mounting:

For mobile installations, the FT220A rack may be used to mount the receiver, making it an easy matter to take out and repair the set. This rack was designed to take 3 receivers so it will be necessary to saw off one and rewire it to suit the plug connections used on the receiver. The switch on the front of the rack may be used for a standby switch and the fuse block on the rear will be handy for a battery lead fuse.

MODIFIED AUDIO SECTION OF BC-454 RECEIVER

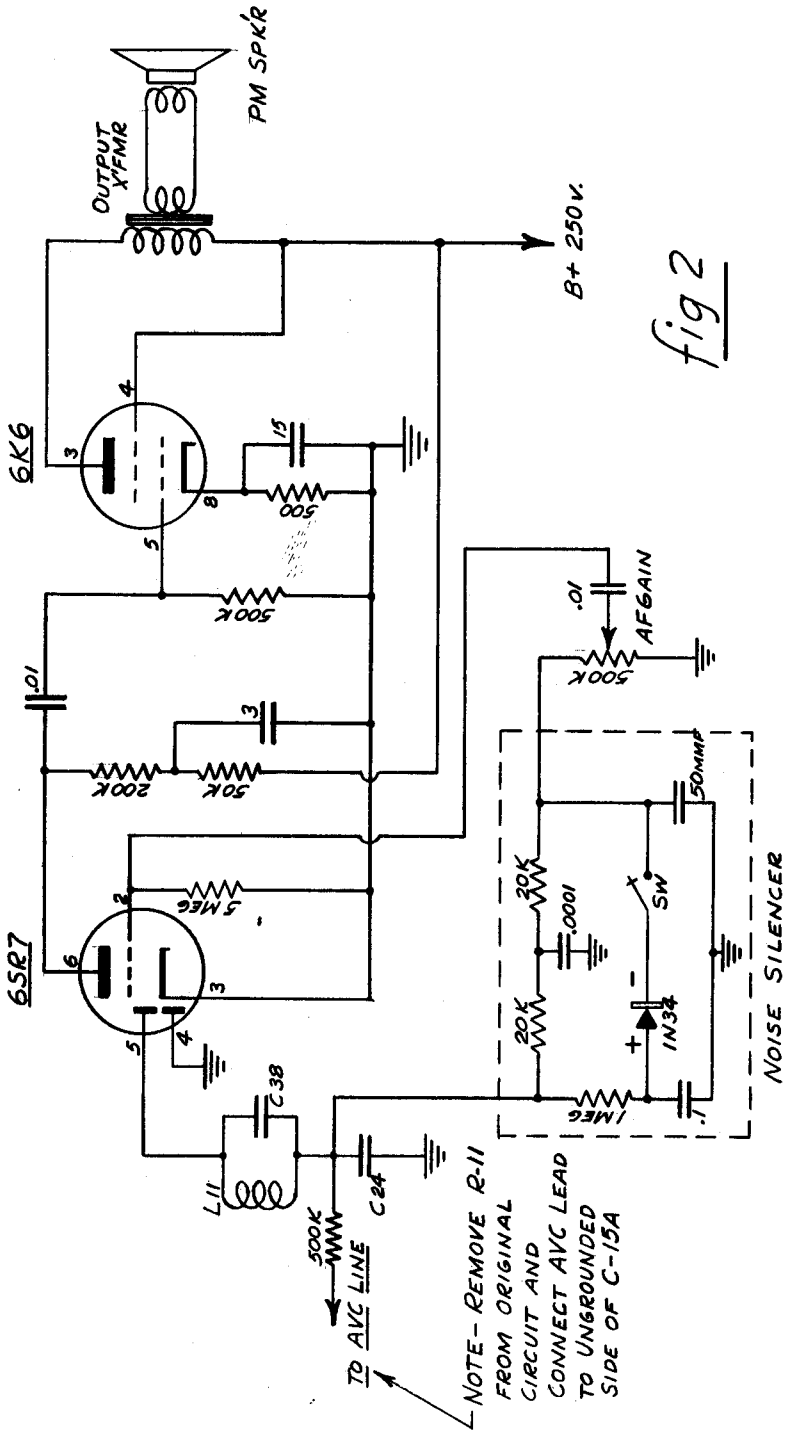

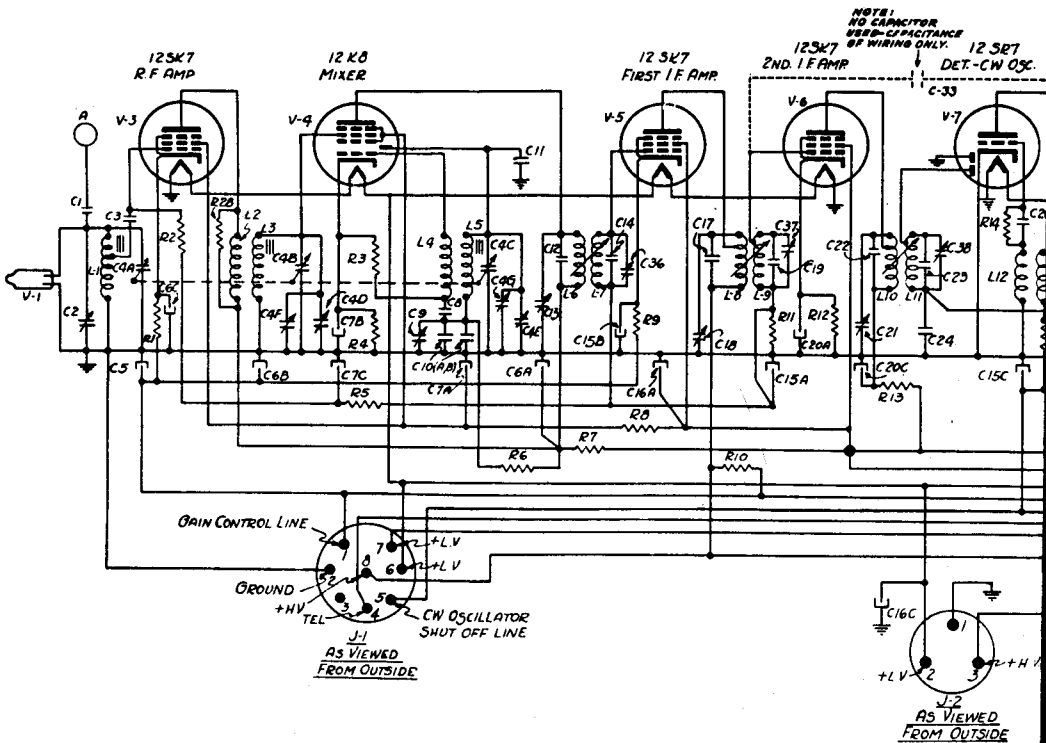

CIRCUITS IN RF COIL SET, IF COUPLING UNITS, CW OSCILLATOR, & OUTPUT TRANSFORMER THE TERMINAL NUMBERS ON THESE UNITS AGREE WITH THOSE SHOWN AT THE CORRESPONDING LOCATIONS ON THE WIRING DIAGRAM

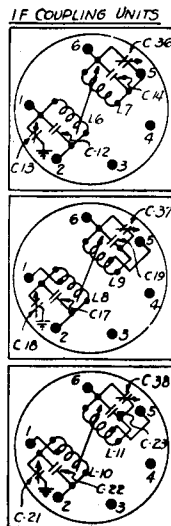
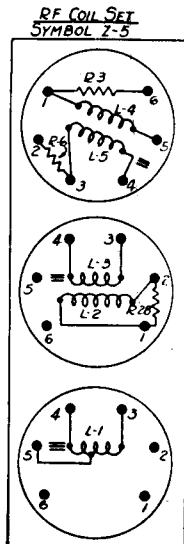

Radio Receiver

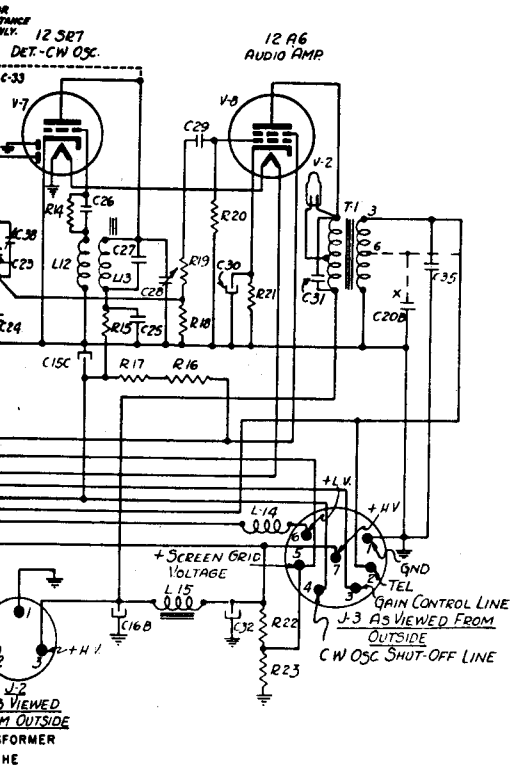

CAPACITANCES		INDUCTANCES		RESISTANCES	
SYMBOL	DESCRIPTION	SYMBOL	DESCRIPTION	SYMBOL	OHMS
C-1	11 MMF	L-1	ANT. INPUT	R-1	620
C-2	16 MMF	L-2, L-3	RF AMP	R-2	2,000,000
C-3	100 MMF	L-4, L-5	RF OSC	R-3	51,900
C-4 (A TO C)	GANG (346 MMF)	L-6, L-7	IN FIRST IF	R-4	620
C-5	3 MFD	L-8, L-9	IN 2ND IF	R-5	150,000
C-6 (A,B,C)	05/05/05 MFD.	L-10, L-11	IN 3RD IF	R-6	300,000
C-7 (A,B,C)	05/05/05 MFD	L-12, L-13	CW OSC	R-7	200
C-8	200 MMF	L-14	RF CHOKER	R-8	200
C-9	40 MMF			R-9	620
C-10 (A,B)	670 MMF TOTAL			R-10	360,000
C-11	3 MMF	L-15	112 MICRO-HENRIES	R-11	100,000
C-12	180 MMF			R-12	510
C-13	17 MMF			R-13	200
C-14	180 MMF			R-14	100,000
C-15 (A,B,C)	05/05/05 MFD			R-15	20,000
C-16 (A,B,C)	22/22/22 MFD			R-16	100,000
C-17	180 MMF			R-17	100,000
C-18	17 MMF			R-18	510,000
C-19	180 MMF			R-19	100,000
C-20 (A,B,C)	05/01/05 MFD			R-20	2,000,000
C-21	17 MMF			R-21	1500
C-22	180 MMF			R-22	7000
C-23	180 MMF			R-23	7000
C-24	200 MMF			R-26	51,000
C-25	.001 MFD				
C-26	100 MMF				
C-27	335 MMF				
C-28	34 MMF				
C-29	.006 MFD				
C-30	15 MFD				
C-31	.001 MFD				
C-32	5 MFD				
C-33	WIRING CAPACITANCE LESS THAN 2 MMF				
C-35	750 MMFD (SEE NOTE BELOW)				
C-36	17 MMF				
C-37	17 MMF				
C-38	17 MMF				

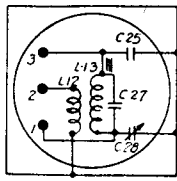

SYMBOL Z-4
CW OSCILLATOR
(239 KC)

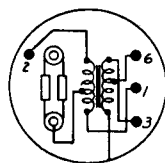

SYMBOL T-1
OUTPUT TRANSFORMER

④ C-35 & TERMINAL 3 TO BE USED FOR 4000 OHM OUTPUT
C-20B & TERMINAL 6 TO BE USED FOR 300 OHM OUTPUT

FIG. 1

TUBE SOCKET TERMINALS
AS VIEWED FROM BOTTOM

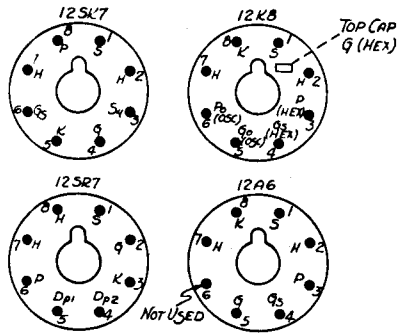

TUBE TERMINAL CODE

- S = SHELL
- H = HEATER
- K = CATHODE
- S₄ = SUPPRESSOR GRID
- D_{p1} = FIRST DIODE PLATE
- D_{p2} = SECOND DIODE PLATE
- Q = CONTROL GRID
- Q₅ = SCREEN GRID
- Q₅(HEX) = SCREEN GRID, HEXODE SECTION
- Q₀(OSC) = CONTROL GRID, OSC. SECTION
- P = PLATE
- P(HEX) = PLATE, HEXODE SECTION
- P₀(OSC) = PLATE, OSC. SECTION
- Q(HEX) = CONTROL GRID, (HEXODE SECTION)

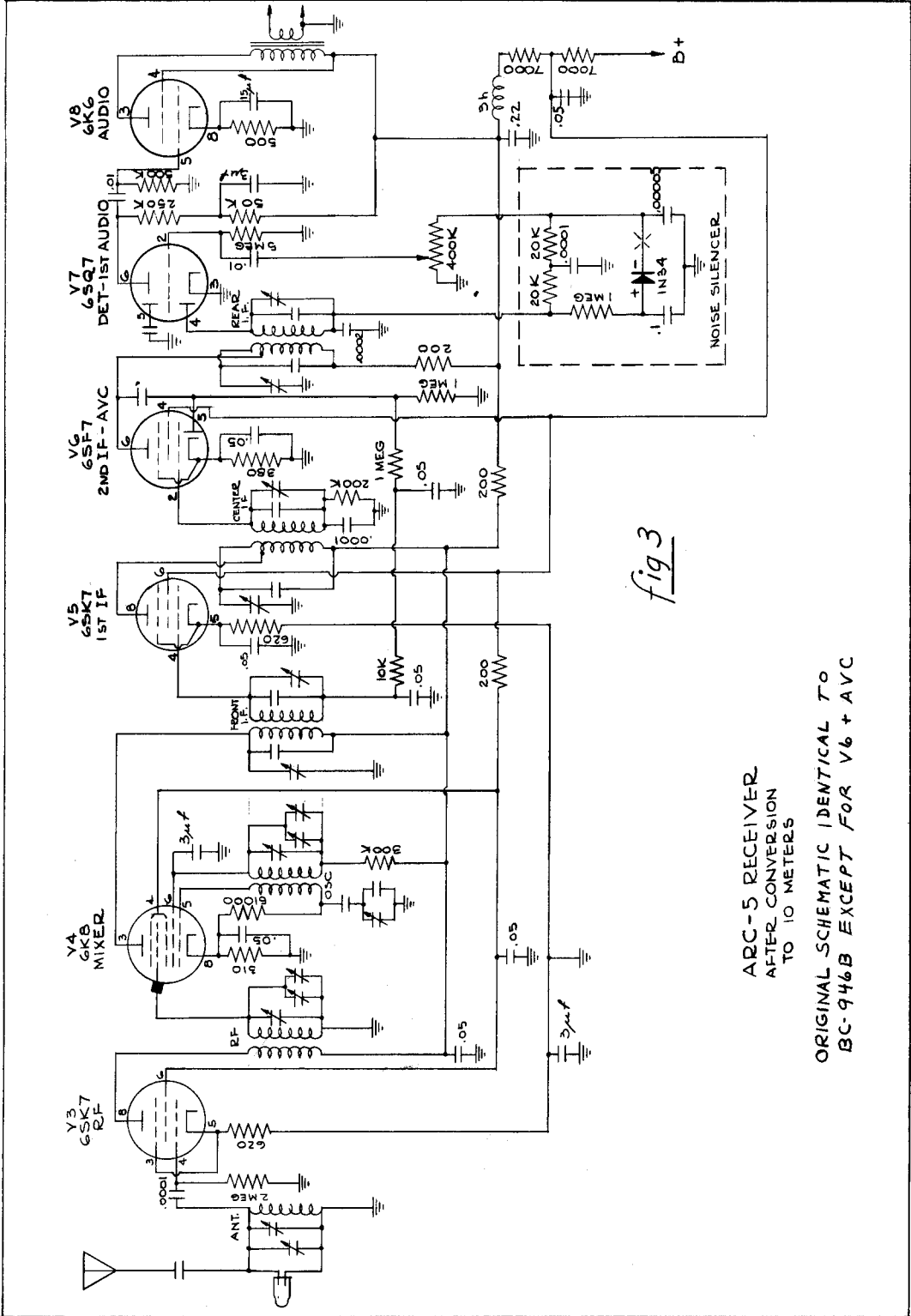

fig 3

ARC-5 RECEIVER
AFTER CONVERSION
TO 10 METERS

ORIGINAL SCHEMATIC IDENTICAL TO
BC-946B EXCEPT FOR V6 + AVC

POWER SUPPLY FOR SCR-274N & ARC-5
RECEIVERS

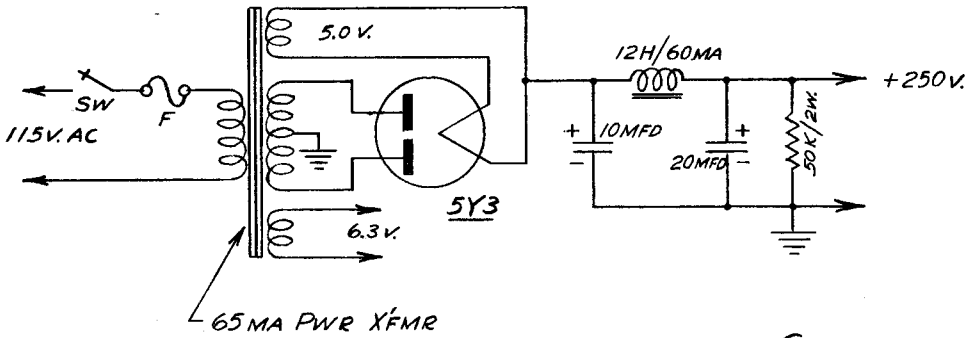
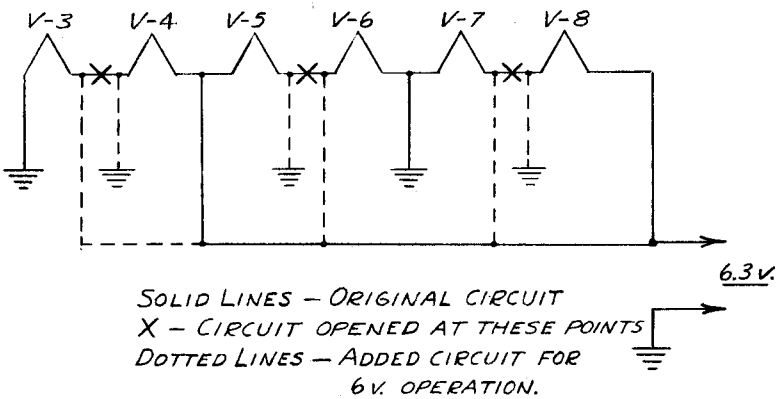

fig 4

FILAMENT CIRCUIT



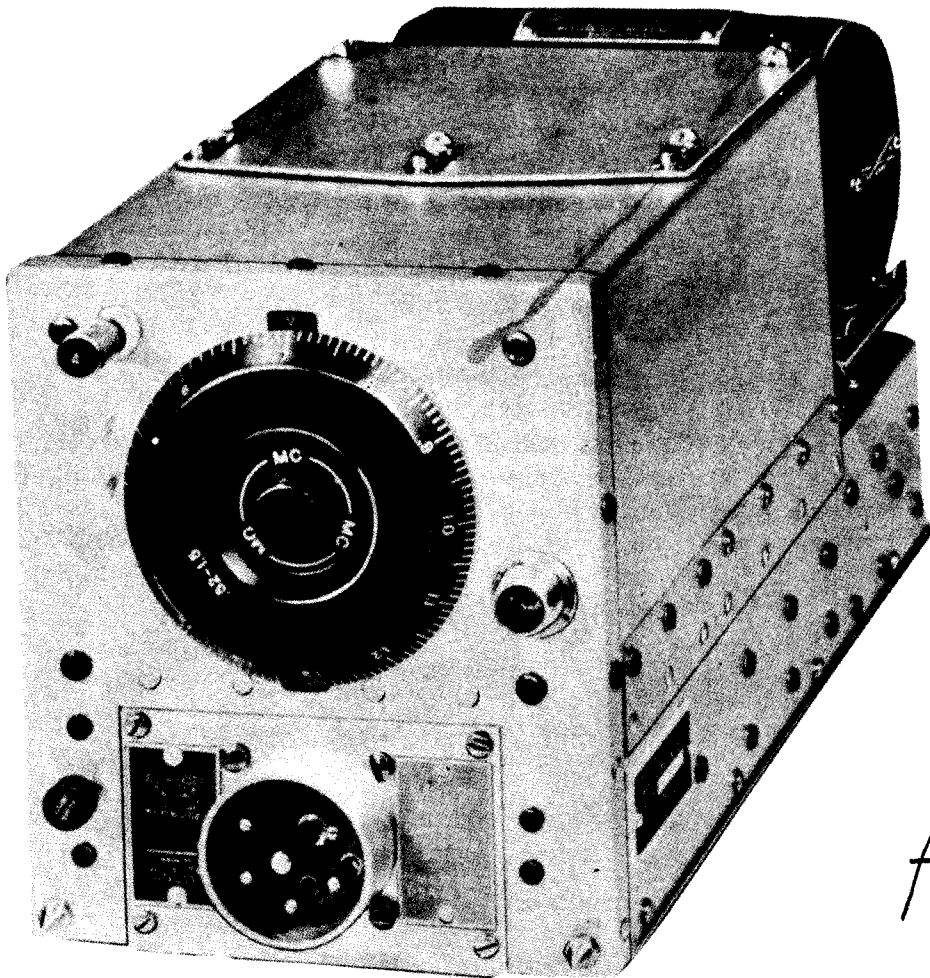

fig 5

BC-454 RECEIVER (Before Conversion)

Typical of Command Set Type Receivers

APS-13 TRANSMITTER/RECEIVER FOR 420-MC. OPERATION

The AN/APS-13 Transmitter/Receiver is a low-powered airborne radar unit, designed and used as a warning device for rear approaching enemy aircraft. It was commonly referred to as the "Tail-End Charlie" and operated audible indicators when rear approaching aircraft were within operating range of the unit.

The unit is completely enclosed and weighs approximately 12-1/2 pounds. It operated from 28 volts DC, requiring 3.25 amperes, with a self-contained dynamotor supplying the "B" voltage.

Since the APS-13 is designed to operate in the 420-Mc. range, no major revamping of the tuned circuits in the transmitter and receiver sections is required for amateur use. However, the pulse modulator and other components for the radar functions are not used and therefore are modified or removed from the unit.

(a) Description:

Two 6J6's operating in parallel push-pull as a self-excited oscillator form the transmitter section of the APS-13. Tuning of the transmitter is accomplished by a screwdriver control on the front panel which slides a shorting bar along the 1/4-wave plate line. The antenna circuit is coupled to the 1/4-wave line by means of a "hair pin" pick-up loop which is variable by screwdriver adjustment. Coupling of the antenna circuit is also controlled by the variable antenna loading condenser, C-159.

The receiver section consists of the front-end section (6J6 oscillator and 6J6 mixer), 30-Mc. IF, detector and video. The video output controls audible and visual indicators through the two 2D21 thyatron and associated relay circuits.

Tuning of the receiver "front-end" is accomplished by screwdriver adjustments from the front panel. The tuning arrangement consists of a shorting bar on the oscillator line and mechanical rotation of condenser plates on the mixer line.

Converted for amateur use, the APS-13 includes the original receiver "front-end" and IF section with an added audio section for AM reception. The audio section also serves as a plate modulator for the transmitter. A conventional AC power supply is also included in the modified version.

(b) Removal of Parts:

For AM operation it is obvious that the pulse modulator must be replaced and the receiver modified for audio reception. This eliminates the pulse forming networks and other associated components used for radar operation as listed below:

Dynamotor D-101

Relay K-101, with terminal board and associated parts.

RF Transformers T-108, T-109, T-110, T-111, T-112, T-113, T-114, T-115, & T-116

Condensers C-157, C-158 (A & B)

Coil L-111

Tubes & Sockets V-110, V-111, V-114, V-115, V-116, & V-117, with all small immediately associated parts.

Terminal Boards E-116 (on back of front panel), with associated parts.

E-103 (associated with V-109; leave tube and socket).

Plug J-101 (on front panel).

Cover Plate (on front panel) with associated C-115, C-209, L-153, & L-154

Coax Line (on front panel) temporarily removed

Receiver front-end section " "

Transmitter section " "

Removal of the above components leaves primarily only the IF section. Temporary removal of the transmitter and receiver front-end sections becomes apparent in the following mechanical modifications.

(c) Addition of Components and Controls:

From Fig. 1, it is apparent that the center section of the chassis is cut out with a hacksaw and replaced with a new solid section of sheet dural or aluminum. This operation permits better mounting of the added components and improves the appearance of the completed unit. Dimensions of the removed section and new section are given in Fig. 1.

Before replacing the new chassis section, drilling and cutting of mounting holes for the major added components should be done. The location of these components, power supply and so forth, is not critical and can be determined approximately from the photos.

The following controls and components are located on the front panel:

- AF Gain Control (in former position of "Regulation Control")
- RF Gain Control (provided with shaft extension for control knob)
- Speaker Plug (4 prong socket in former position of J-101)
- Microphone Jack (to correspond to microphone used, T-17, etc.)
- Transmit-Receive Switch (4 pole, 2 position)
- Coax Mounting Bracket (remounted to clear receiver controls as shown in photographs)
- Receiver Oscillator Tuning Control (adapted for knob)

(d) Receiver Front-End Section:

Before replacing the receiver front-end section, the removal of several parts and reconnection of the heaters is necessary. Parts to be removed include C-143, C-144 and C-145 feed-through type condensers with terminal board E-119 and all immediately associated parts located on the side adjacent to the oscillator tuning line. The yellow lead to the cathode of V-101 is also removed.

The heater circuit for this section is reconnected for 6-volt operation as shown in the converted schematic diagram, Fig. 5. It should be noted that all the RFC's are used.

To facilitate receiver operation, the existing screwdriver oscillator tuning should be modified for a knob control. This is easily accomplished by using a standard 1/4" shaft extension as shown in Fig. 2. If desired, this same treatment may be used for the screwdriver mixer tuning control.

After the receiver front-end section is replaced in its original position on the chassis, it is reconnected as shown in Fig. 5.

(e) Receiver IF Section:

From the converted schematic diagram, Fig. 5, it is apparent that the five 30 Mc. IF stages are left intact and that only slight circuit changes are made. These primarily involve the voltage supply circuits and the RF gain control.

To obtain correct voltages for the screen grid buss and the plates of the IF amplifier stages, dropping resistors are used with by-pass condensers for ample decoupling. If sufficient decoupling is not used, "motorboating" may occur through the power supply from the AF section.

The new RF gain control varies the screen voltage on the first IF stage. The former RF gain control (cathode circuit of fifth IF amplifier) is removed with the cathode resistor, R-132, being run directly to ground.

Unfortunately in most cases, the upper slug adjusting screws of the IF transformers were clipped off at their stagger-tuned settings. This practically eliminates realignment of the stages in order to narrow the existing pass band. However, this is not too objectionable since there is ample gain available. Also, a relatively wide pass band is desirable to compensate for frequency instability of the modulated self-excited oscillators commonly used in the u.h.f. bands.

It should be noted that slight retuning can be accomplished by careful adjustment of the primary slugs (lower ones). Peaking on noise is satisfactory.

(f) Audio Section:

The added audio section consists of 3 stages: the plate detector (6AG5), first audio amplifier (6AG5), and the second audio power amplifier (6V6). This circuit is of conventional design utilizing as many of the original parts as possible. It should be noted that the microphone circuit derives its excitation voltage from the cathode resistor of the 6V6 stage.

The output transformer is of the conventional push-pull to voice-coil type which utilizes half of the primary winding as a secondary for modulating the transmitter. With the "T-R" switch in the transmit position, the speaker voice coil (secondary) circuit is opened, giving a 1:1 impedance ratio to the plates of the transmitter oscillator.

It should be noted that the "T-R" switch disables the receiver section by removing the plate voltage from the IF section during the transmit period. In the transmit position, the mike transformer secondary is switched into the grid circuit of the first audio amplifier. Also the oscillator becomes active when its cathode circuit is completed by the "T-R" switch in the transmit position.

(g) Transmitter Section:

The transmitter section remains virtually unchanged with exception of the removal of R-155 and R-156. As in the receiver section, the heater circuits are reconnected for 6-volt operation with all the RFC's used. After the transmitter is replaced on the chassis in its former position, it is reconnected as shown in Fig. 5.

(h) Power Supply:

Power requirements for the converted APS-13 are 6.3 volts at 4.3 amperes for the heater circuit, and 300 volts DC at approximately 80 ma. for the plate supply.

The power supply shown in Fig. 5 is adequate for the above requirements and can be conveniently placed on the new chassis section as shown in the photographs. The AC power switch may be located at the AF gain control or separately on the front panel as desired.

(i) Adjustments and Operation:

Before attempting adjustment of the receiver and transmitter, all voltages should be checked. Readings should approximate the values shown on the converted schematic diagram.

If the AF and IF sections are functioning, the oscillator "hiss" (noise) should be heard at the speaker output with its level being varied by both the AF and RF gain controls.

With the oscillator tuning set at its approximate mid-position, the mixer can be tuned through resonance with an obvious increase in noise level at the resonant point. Mixer resonance should occur near the open position of its condenser plates. If it is not near this point, the tuning range of the mixer can be shifted by moving the shorting bar on the mixer line. Generally this adjustment is not necessary.

Further adjustment of the receiver tuning must be done with an external signal or ignition noise.

In coupling the receiver input to the antenna, adjustment of padder condenser, C-119 (labeled "B" on panel) and the "hair-pin" coupling loop is necessary. Adjustment of the padder condenser, C-119, is critical for optimum performance.

If the self-excited transmitter is oscillating ("T-R" switch in transmit position), its grid voltage will be approximately -22 volts. This reading is obtained when the oscillator is not loaded.

Loading of the transmitter is adjusted by C-159 and the "hair-pin" coupling loop. Under loaded conditions, the plate current of the oscillator should not exceed 50 ma. Normal readings will be around 45 ma. It should be noted that this type of oscillator may not oscillate when too heavily loaded.

Modulation level is adjusted by the AF gain control in the audio section. In normal operation, the AF gain is left at its proper modulation setting for transmission, with the RF gain being adjusted for the desired receiver output level.

For transmitter adjustment, the ordinary 28-volt dial lamp provides a good indicator for RF output and modulation of the RF output.

After connecting the coax matching section to the receiver and transmitter, it is necessary to make slight tuning readjustments both for the transmitter and receiver. When using the antenna matching section, tuning interaction between the transmitter and receiver requires careful adjustment for optimum operation.

Satisfactory operation can be had by using the converted APS-13 with a multi-element beam fed with 52-ohm coax. For proper matching, a series 1/4-wave line section can be used.

(j) Optional Refinements:

For those who may desire to improve further their converted APS-13, the following suggestions may be of interest:

(1) By carefully locating the added components on the new chassis section, sufficient space can be obtained for mounting a small PM speaker on the inside of the front panel. This necessitates cutting a hole or drilling the front panel for the speaker grill-work. With the speaker mounted internally, the speaker plug can be eliminated.

(2) Higher efficiency in the antenna circuit can be obtained by replacing the existing coaxial matching section with an antenna switching relay. This relay may preferably be of the coaxial type.

(3) For added sensitivity and higher signal noise ratio, an added RF stage can be used ahead of the receiver "front-end". Excellent results can be had by using the light-house tube with coaxial tank circuits.

(4) Better performance can be had by using voltage regulation from a VR-105 (used in the original circuit) for the screen supply voltage of the IF amplifier section.

(5) For optimum transmitter adjustment, metering of the grid and plate circuits is very helpful. Also, at these frequencies a field strength meter is advantageous in tuning antenna systems.

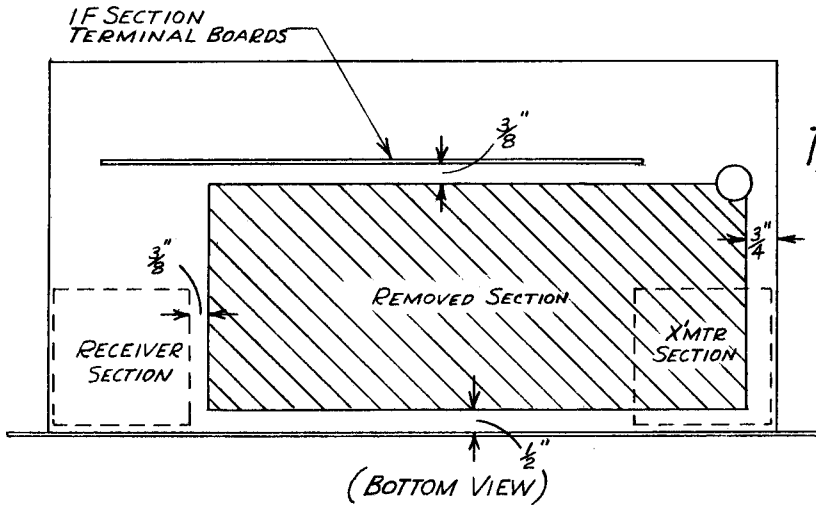

fig 1

NEW CHASSIS SECTION
 $11\frac{3}{8} \times 5$, .040" 50 DURAL.
 OLD SECTION SERVES AS
 TEMPLATE FOR X'MTR
 MOUNTING.
 NEW SECTION BOLTED IN
 WITH 6-32 $\times \frac{1}{4}$ SCREWS.

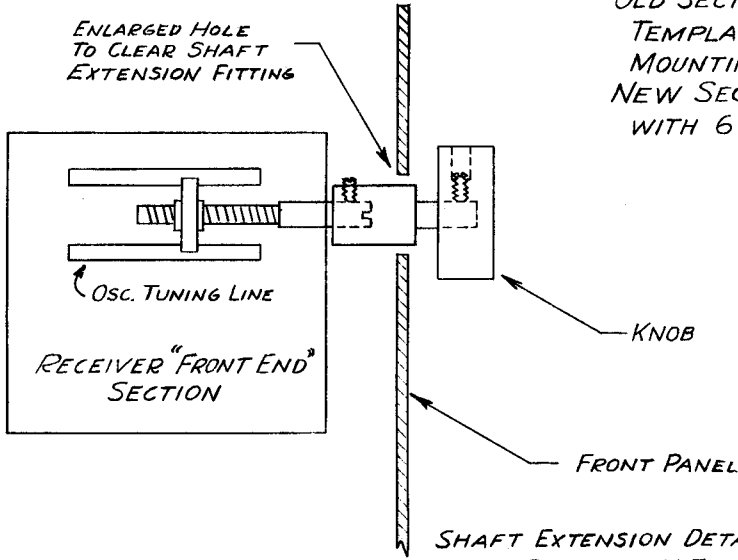
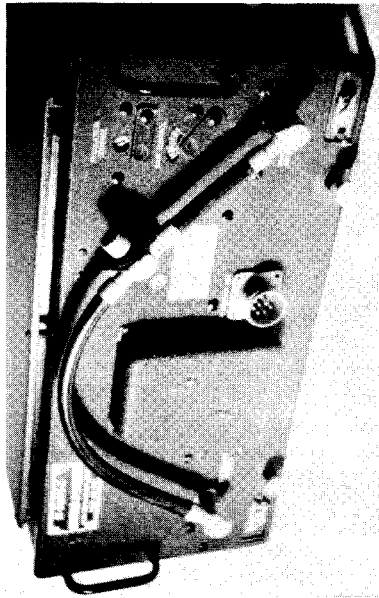

fig 2

SHAFT EXTENSION DETAIL
 FOR RECEIVER H.F.
 OSC. TUNING.

AN/APS-13 PHOTOGRAPHS



(ORIGINAL)

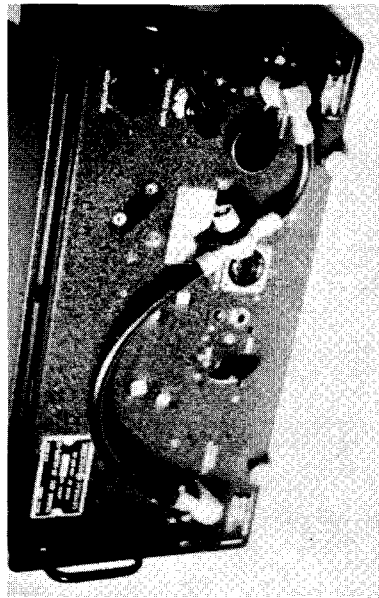
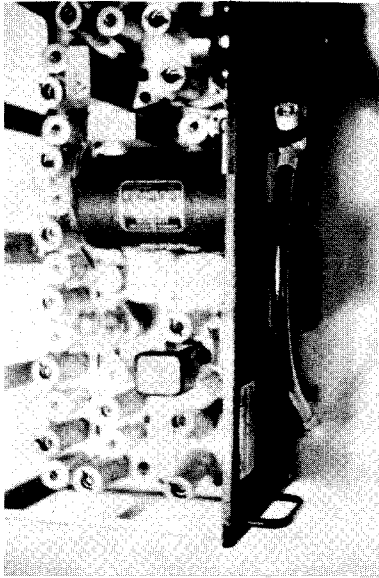

(CONVERTED)

fig 3

APS-13 ORIGINAL

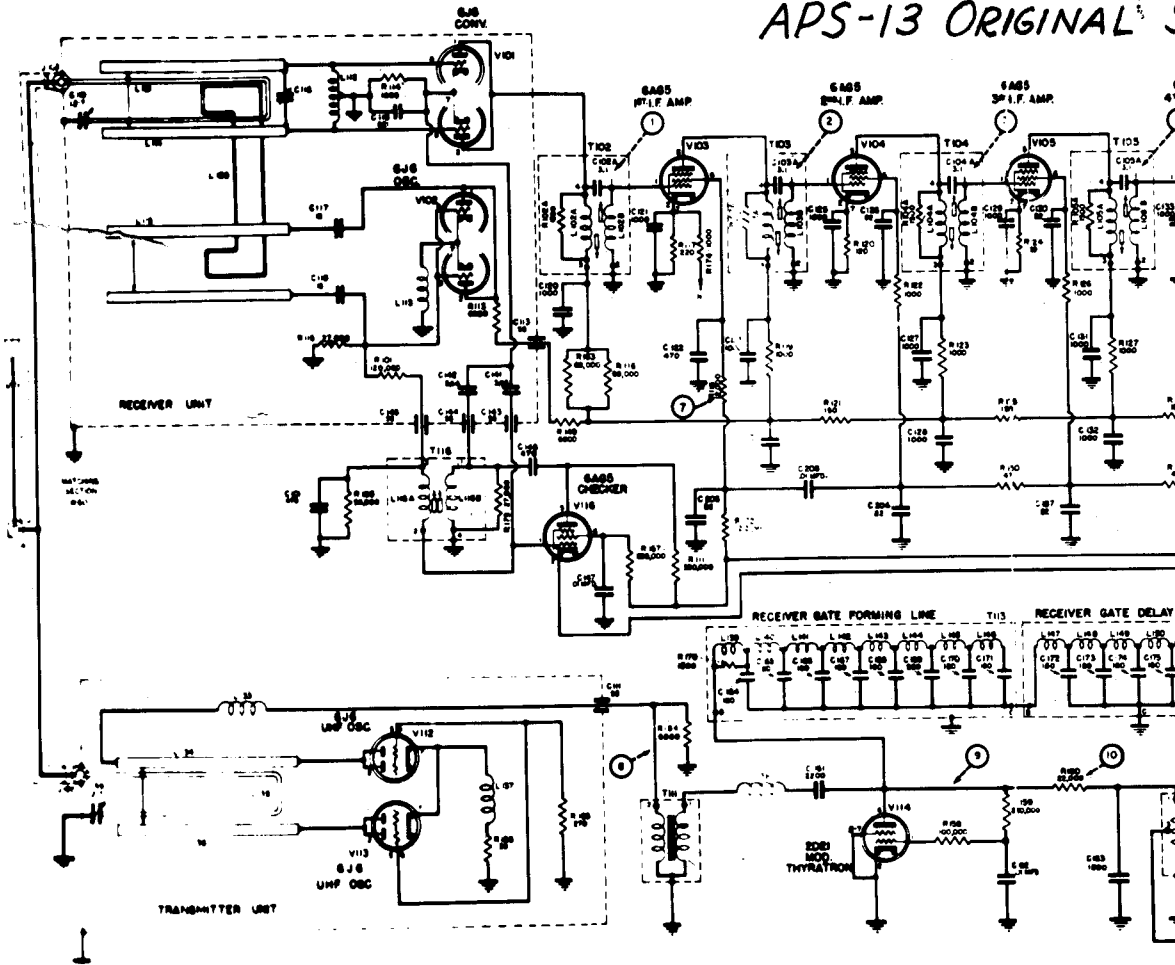

NOTE: CAPACITANCE IN P.F. VALUES IS IN MICROFARADS UNLESS OTHERWISE SPECIFIED.
RESISTANCE IN OHM VALUES UNLESS OTHERWISE SPECIFIED.
RESISTANCE IN K. VALUES UNLESS OTHERWISE SPECIFIED.
RESISTANCE IN M. VALUES UNLESS OTHERWISE SPECIFIED.

fig 4

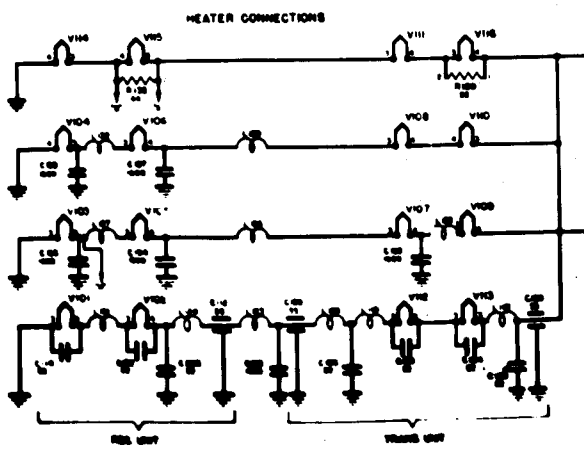

ORIGINAL SCHEMATIC

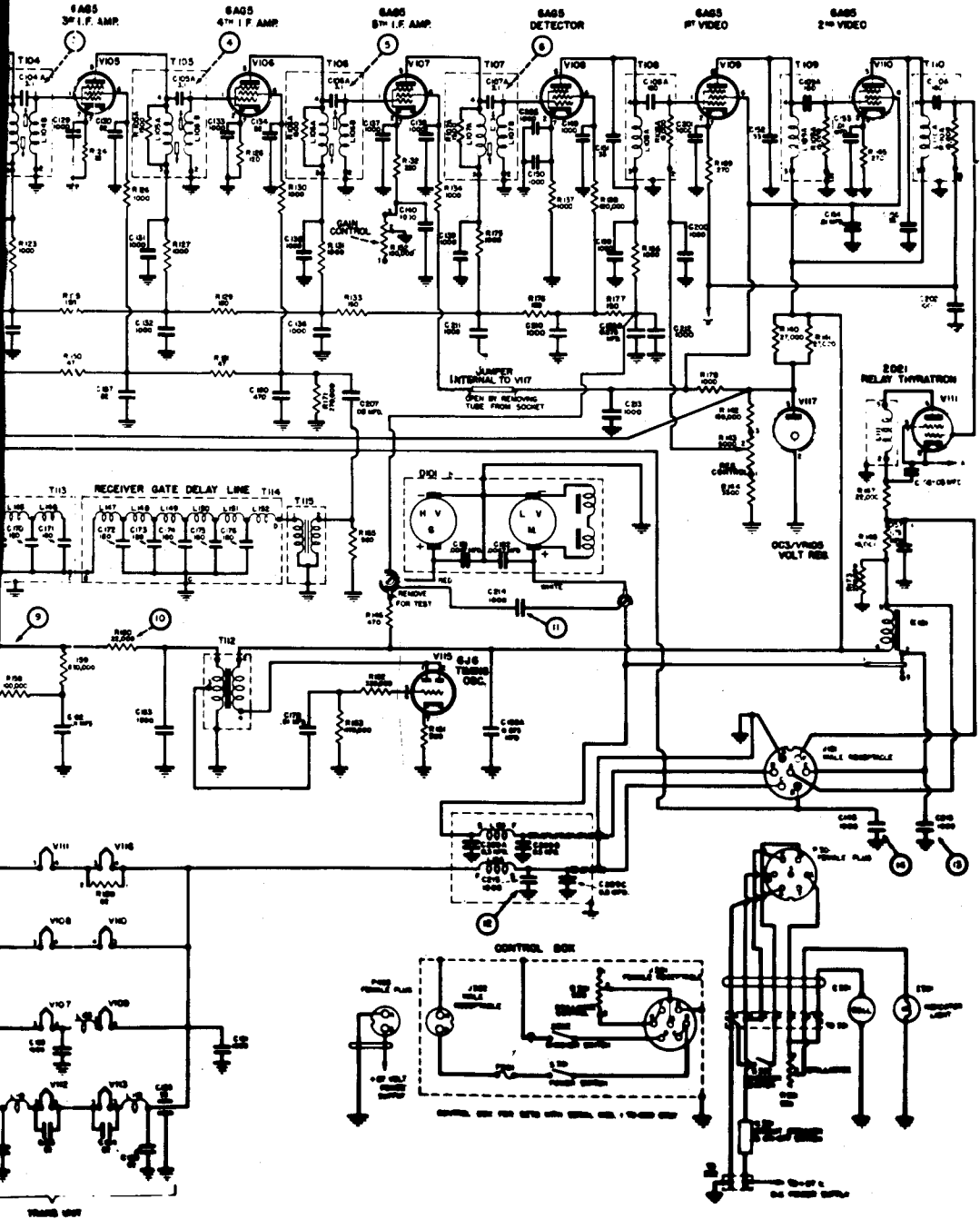

APS-13 SCHEMATIC DIAG

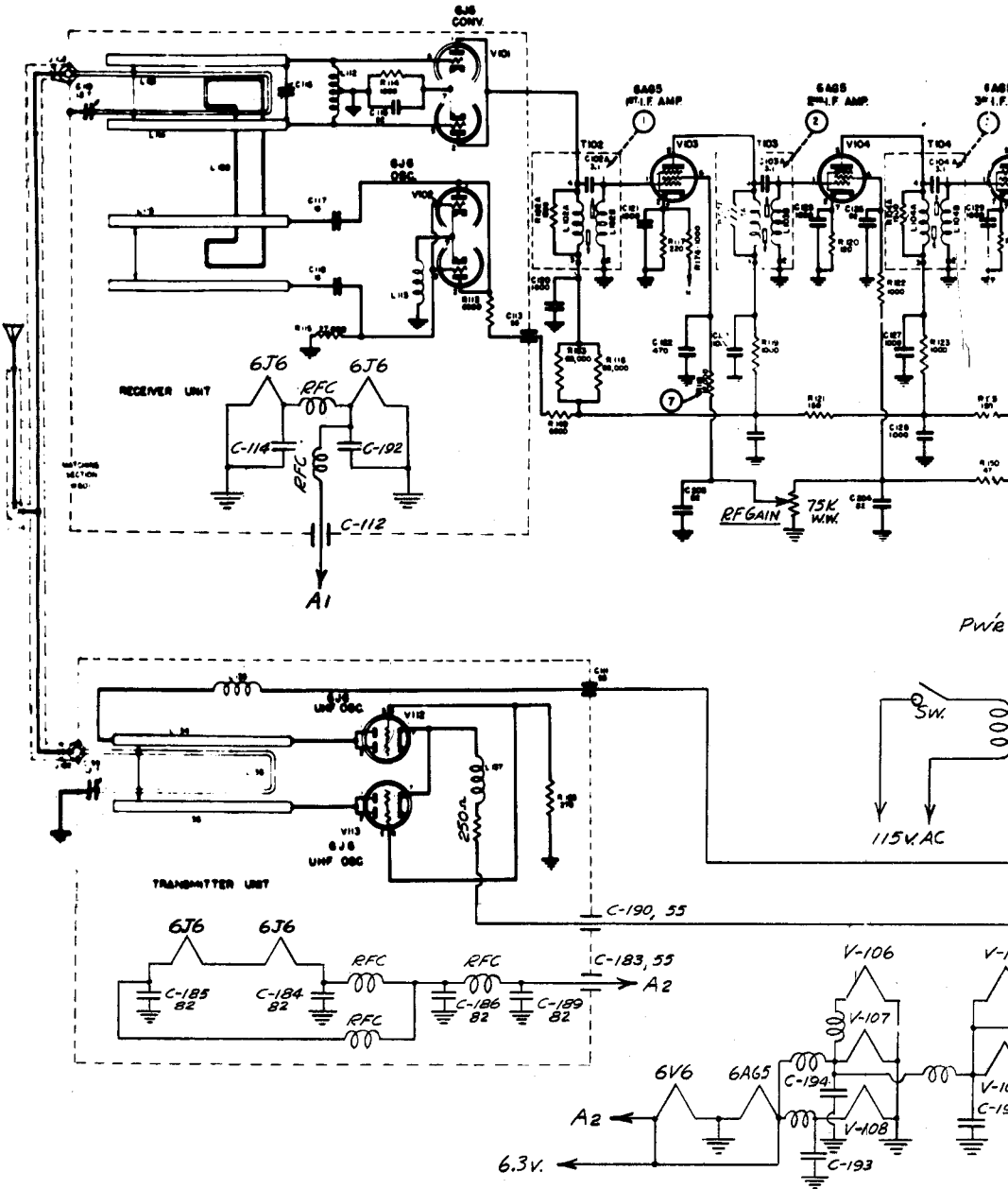
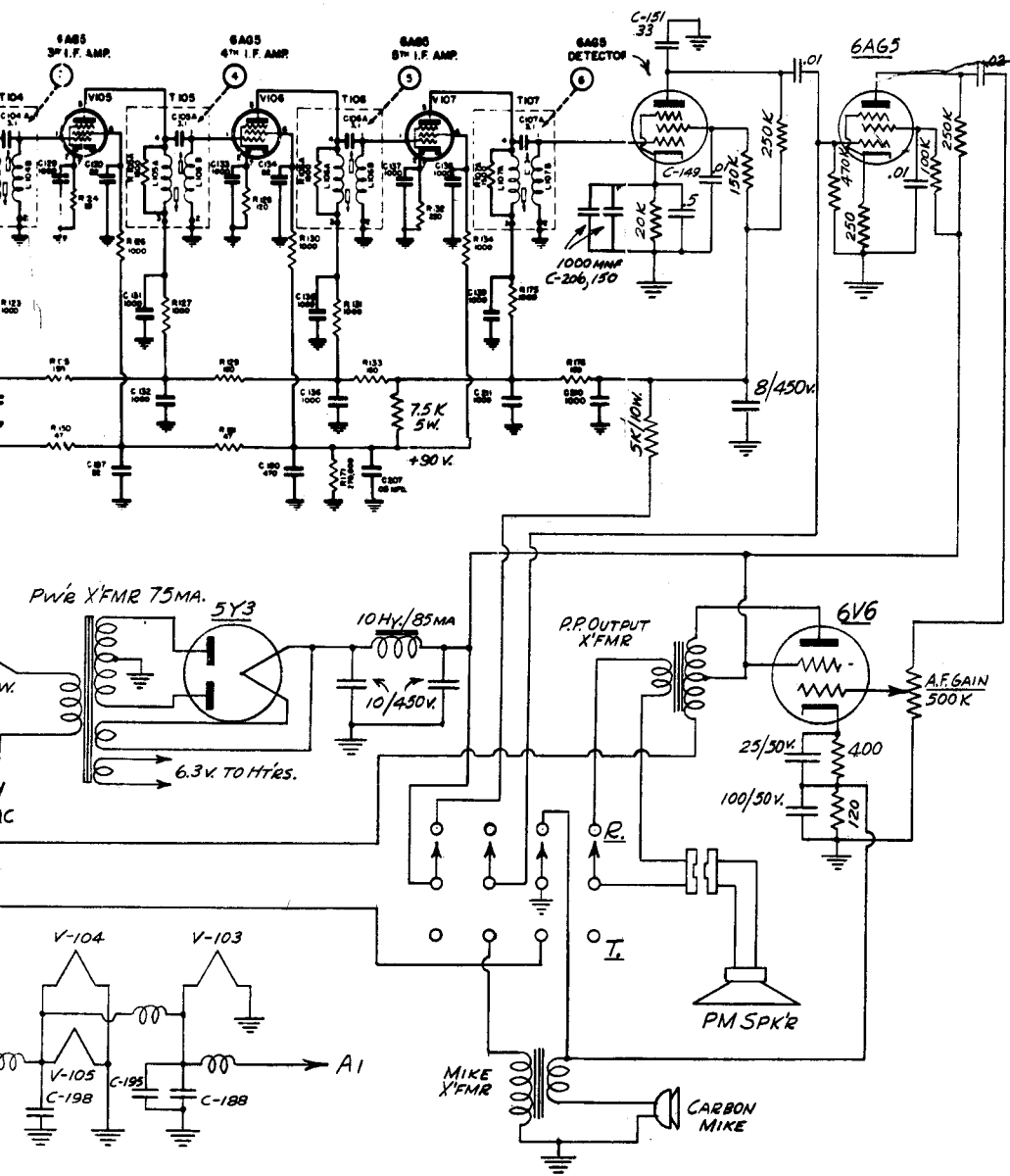

DIAGRAM (CONVERTED)

fig 5



CONVERTING THE ARC-5 OR SCR-274N SERIES TRANSMITTERS FOR 10-METER MOBILE OPERATION

The SCR-274N or ARC-5 series aircraft transmitters, have several good features that justify their modification for 10-meter mobile operation in conjunction with the popular PE-103 dynamotor. This converted transmitter, used in conjunction with the converted 10-meter ARC-5 or BC-454 receiver, also described in this manual, provides the amateur with a satisfactory 28 Mc. mobile rig at a very reasonable cost.

The SCR-274N or ARC-5 series transmitter consists of a stable VFO with a directly calibrated dial driving a pair of parallel 1625's (12-volt 807's). The existing circuit requires 28 volts DC using series-parallel circuits for the 12-volt tubes. The plate voltage supply is obtained from a 28-volt dynamotor located in the separate modulator unit. The circuit also includes a tuning-eye indicator and a plug-in crystal unit for calibration of the VFO.

This conversion deals with the more popular unit, the BC-459, having the fundamental frequency range of 7 to 9.1 Mc. Multiplying by 4, the output frequency becomes 28 to 36.4 Mc which includes the 10-meter band. It becomes apparent that the BC-457, which has a fundamental frequency of 4 to 5.3 Mc, with a frequency multiplication of 6, covers 24 to 31.8 Mc, thus including both the 10 and 11-meter bands. If the BC-457 is used, the only variation required from the conversion described herein is that the stage following the VFO must function as a tripler instead of as a doubler.

(a) Preparation of the Chassis:

From the photographs and the converted circuit it is apparent that all components and associated wiring are removed with the following exceptions: the VFO circuit, coil compartment, and variable condenser C-63 which are left intact; the variable condenser (C-65) which was originally the PA tuning condenser; the mechanical tuning gear and drive arrangement; and the tube sockets.

After stripping the chassis, except for the VFO which is left unaltered, variable condenser C-65 is mechanically uncoupled from the oscillator tuning control shaft. This is accomplished by removing the drive gear from the condenser shaft. The shaft is then extended through a hole in the chassis skirt for an external knob or screwdriver control with a locking device. This condenser becomes part of the PA plate circuit and functions as the antenna loading condenser.

Since a mating plug for the existing J-64 at the rear end of the chassis is not always available, it is replaced with a standard 6-prong tube socket.

Relays K-53 and K-54, along with the antenna connection post, are also removed from the chassis. Relay K-53, which is located on the under side of the chassis, should be saved. After modification it is used for the new antenna switching relay.

(b) Tube Substitution:

For 6-volt operation all the existing 12-volt tubes must be discarded. The 1626 oscillator tube can be directly replaced by a 6J5, its 6-volt equivalent. The metal type is preferred.

The two sub-chassis sockets formerly occupied by the two 1625's are now modified for the 807 (PA) and the 6V6 (second doubler). Due to the different base of the 807, the 7-prong socket holes must be filed out with a small round file to accept the 807 as shown in Fig. 1. Before filing, the spring clips on the bottom of the socket should be removed so as not to damage the contacts. The spring clips are replaced after the pin holes have been modified.

The second sub-chassis socket is modified for mounting the 6V6 octal socket. The spring contacts are removed and discarded by drilling out the rivets. A hole of sufficient diameter is cut in the insulating material to accept a standard ring-mounted octal socket. Care should be exercised to avoid cracking the insulating material.

As shown in Fig. 2, the first doubler (6SK7) occupies the socket of the former calibration indicator (1629). The heater circuit is then wired for parallel operation with one side grounded as shown in the diagram, Fig. 6.

(c) Addition of the Frequency Multiplier Stages:

For conservation of space and ease of operation, permeability tuned coils are used for both doubler stages (14 Mc. & 28 Mc.). These forms are available in all varieties, both surplus and standard manufacture. Since the efficiency of these stages is not of importance and relatively broad tuning is desirable, the distributed circuit capacitance is sufficient for tuning the coils to resonance.

Coil winding data is given in Fig. 4. If forms of different diameter are used, the number of turns should be varied accordingly. The resonant point and harmonic output of the doubler stages can be easily determined with an absorption-type wavemeter. A small neon lamp is also useful for adjusting these stages.

The doubler coils are single-hole mounted to the chassis skirt with the adjustment screw exposed for external adjustment. The first doubler coil is mounted directly under the 6SK7 socket, while the second doubler coil is mounted in the existing hole in the chassis skirt beside the 6V6 socket. The mounting hole was formerly used for the PA padder (C-67) adjustment.

Since the grid leads to both doubler stages are rather long, it is preferable to use shielded cable for both these leads. Low-capacitance mike cable or coax with both ends of the shield grounded should be used.

It should be noted that the first doubler grid is driven from the same point of the VFO that formerly drove the grids of the 1625's. In the first doubler grid circuit, R-74 becomes the grid-leak resistor for the 6SK7; this value should be changed to 100K ohms. Bias for the second doubler is derived both from the grid leak action and from a cathode resistor.

It is important to note the connections to the oscillator coil compartment before removing the original leads. This will eliminate the necessity of removing the oscillator compartment shield to determine the proper connections. Component placement and shortness of leads are important in wiring the two doubler stages as is usual in transmitter design.

(d) Power Amplifier Circuit:

All components, except the antenna loading condenser C-65 and the plate feed RFC are mounted above the chassis. This provides good isolation in addition to convenient mounting and close grouping of components. The PA plate tuning condenser is mounted as near the 807 socket as possible and is controlled by the former antenna loading control shaft and knob. This shaft is modified for coupling to the condenser shaft as shown in the photos. The final tank, (L-3) is mounted vertically beside the PA tuning condenser.

A centralized junction point for the RF leads from the antenna coupling condenser, the final tank, and the antenna loading condenser is made by relocating the porcelain feed-through button as shown in the photograph.

For isolation, the PA feed RFC is located under the chassis with its associated by-pass condenser directly between the end of the antenna loading condenser and the chassis skirt.

(e) Antenna Circuit:

As indicated in the converted schematic diagram, Fig. 6, the PA tank circuit and the antenna loading condenser form a pi-network. With each setting of the loading condenser, the PA tank must be retuned to resonance. Greater loading requires less capacitance in the loading condenser and more capacitance in the PA tuning condenser to maintain resonance.

The original relay K-53 is modified by rewinding it for 6-volt operation and revamping the contacts as shown in Fig. 3. With the relay in its open position (un-excited) the transmitter RF circuit to the antenna is open and the receiver is switched to the antenna. The relay is mounted inside the transmitter front panel in the former position of K-54 without the necessity of drilling new holes. The antenna switching relay is coupled to the pi-network through a .001 mfd. silver-mica condenser.

(f) Metering:

The second doubler grid, PA grid, and the PA plate circuits are metered. Midget closed-circuit jacks are located on the chassis skirt as near to the circuits concerned as possible. The locations should be apparent from the photographs.

If a single meter is used, the proper shunt values must be determined for the circuits concerned. A 0-1 ma. meter can be used satisfactorily with approximate shunt values of 15 ohms for R_a and 0.75 ohms for R_b . If accurate readings are desired, shunts must be determined experimentally for the individual 0-1 ma. meter used.

(g) Modulator:

The modulator described herein is capable of delivering 12 watts of audio power which will satisfactorily plate modulate 25 to 30 watts input to the power amplifier.

A separate, completely enclosed, chassis is used for the modulator. As shown in the photographs, the chassis from the AM-26 Interphone Amplifier will serve the purpose satisfactorily; however, any chassis of similar size can be used.

The circuit consists of push-pull 6V6's driven by a push-pull connected 6SN7 which in turn is driven by the surplus T-17 single-button carbon microphone. Transformer requirements include a mike to push-pull grids transformer and a modulation transformer such as the UTC S-18. The impedance transformation from the 6V6 plates to the 807 is 9000 to approximately 6000 ohms. The actual impedance of the PA will depend upon the loading of the PA circuit.

To avoid poor voltage regulation and large dissipation in a dropping resistor, the full 500-volt output of the PE-103 dynamotor is applied to the plates of the 6V6's. To permit this high voltage, the cathode bias is increased considerably above that used in normal audio applications. Normal voltages for the screens of the 6V6's and the 6SN7 as well as for the low voltage stages in the transmitter are obtained through dropping resistors as shown in Fig. 6.

One feature to be noted is that the mike excitation is obtained from a tap on the cathode resistor of the 6V6's. This consists of a potentiometer in series with the cathode resistor at the low potential end. The swinger of the potentiometer supplies the excitation voltage for the mike and also serves as a mike gain control. This is an optional arrangement since the mike voltage can also be obtained from the 6-volt automobile battery through an appropriate RC hash filter.

(h) Control Circuits:

Because the transmitter, modulator, and dynamotor are normally located in the trunk or rear section of the automobile, a remote control box is required for operation from the front seat of the car. This control box is usually located at some convenient point on the dash panel and includes a mike jack (for PL-66), a toggle switch (s.p.s.t.) and a pilot lamp.

Since slow-heating cathode-type tubes are used in this version, the heater circuit must be separately controlled from the high-voltage circuit. To avoid damage to the tubes, the heaters should be on approximately 30 seconds before the high voltage from the PE-103 is applied.

From the control circuit diagram, Fig. 7, it is evident that a separate power switch operates the heater circuit and also the pilot lamp circuit in the control box. Closing the "push-to-talk" switch on the hand microphone operates the dynamotor relay circuit and the antenna switching relay.

Even though it is preferable to use a separate relay for the heater circuit, in this instance it can be eliminated if a heavy No. 8 or No. 10 lead of minimum length is used between the modulator and the Remote Control Box. Voltage drop is not appreciable since the current in this circuit only approximates 3 amperes.

The total load drawn from the car battery when operating the transmitter will be approximately 25 amperes. Normal operation and tuning adjustments will not overload the circuit breakers in the PE-103; if they do open, trouble can be expected in the transmitter and modulator circuits. The connection diagram and operation for the control circuits should be self-explanatory from Fig. 7.

(i) Operation:

Preliminary operation and adjustment should be done on the bench with reduced voltage (200 to 250 volts) on the PA. This precaution is obvious since PA bias is derived by the grid-leak action. The lack of RF excitation to the grid of the 807 would result in permanent damage to the tube if high voltage were used. However, the VFO always oscillates, while crystal oscillators often do not.

With low voltage applied to the transmitter, set the oscillator at approximately 7.25 Mc. and adjust the two doublers to their proper harmonic. As previously mentioned, this is easily checked by an absorption-type wave meter. The second and fourth harmonics are 14.5 Mc. and 29 Mc. respectively.

If the doubler stages are resonant at their proper frequency, the final stage can be tuned to 29 Mc. as indicated by the dip in its plate current. For this initial adjustment, the antenna loading condenser should be set at its maximum capacitance (minimum loading). This results in the most pronounced dip in the PA plate current.

The modulator may be separately checked by connecting an ordinary output transformer and PM speaker to the secondary of the modulation transformer. Audible check for distortion and response should be sufficient in this case. The power output can be roughly checked along with the amount of excitation voltage for the mike by measuring the a-c voltage across a 6000-ohm, 10-watt resistor connected across the output of the modulator.

Before replacing the covers on the completed transmitter, the VFO should be recalibrated. This is necessary in order to compensate for the slight electrical differences in the new circuit following the VFO, and for variation between the former 1626 and the 6J5. Recalibrating is a simple operation and is done by setting the VFO dial to 7.50 Mc. and beating its second harmonic with WWV's 15 Mc. signal in your receiver. Zero beat is attained by adjusting the oscillator padder condenser (C-60) accessible through the top of the VFO coil compartment. Generally, the oscillator inductance (slug adjustment, exposed screw on top of VFO coil compartment) need not be changed.

Due to the relatively broad tuning of the multiplier stages and the loaded PA circuit, the transmitter frequency can be shifted considerably by merely tuning the VFO.

When the transmitter is functioning properly, full voltage may be applied to it and the modulator from the PE-103 with the following expected meter readings:

Second Doubler Grid Current	0.6 ma.
PA Grid Current	4 to 5 ma.
PA Plate Current	80 to 90 ma. (normal loading)

When loading the PA to the 1/4-wave (approx. 100 inches) whip antenna or a dummy antenna, the capacitance in the loading condenser is decreased as the loading is increased. As previously mentioned, the final tank circuit must be retuned to resonance for each new setting of the loading condenser. Normal loading for the PA should be between 80 to 90 ma. with the full applied voltage.

(j) Optional Refinements:

For those who may desire additional refinements, the following suggestions may be of interest:

(1) Monitoring Circuit, especially useful for checking the transmitter output can be added with a one-turn pick-up coil at the cold end of the PA tank coil. The output from the circuit shown in Fig. 5 is brought out to the transmitter front panel for high impedance phones.

(2) Resonance Indicator, which consists of a pick-up turn at the cold end of the PA tank coil with a .15 ampere pilot lamp, provides easier adjustment of the PA tuning. The pilot lamp can be located directly behind the plastic window on the transmitter front panel.

(3) Heater Circuit Relay, which avoids the necessity of heavy leads to the remote control box, can be placed in the heater circuit and located on the modulator chassis. This relay can be wired for both local and remote control.

(4) Metering, can be more elaborately done by mounting a 2-inch O-1 ma. meter in the front panel of the transmitter with a rotary switch and circuit as shown in Fig. 5.

(5) Crystal Microphone, can be added with an extra stage of voltage amplification at the front end of the modulator. This stage should consist of a 6F5, 6J7, or similar tube. The circuit can be located at the remote control box as the pre-amplifier and must incorporate the conventional mike gain control.

(6) Stabilization of the VFO, can be slightly improved by regulating its plate-supply voltage. This can be accomplished in the conventional manner through the use of VR tubes.

(7) Mounting For the Transmitter, can be facilitated by using its regularly associated FT-226A mounting rack. By using both sections of the rack, both the transmitter and modulator can be mounted. This will also provide convenient removal of the units for adjustment and servicing.

For additional data, refer to Volume I of the "Surplus Radio Conversion Manual", "SCR-274N Transmitter Conversion to VFO."

BOTTOM VIEW OF SOCKET

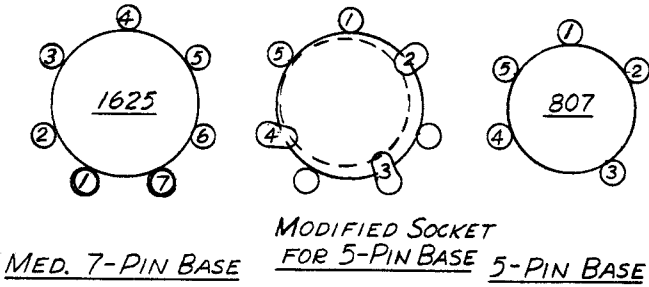
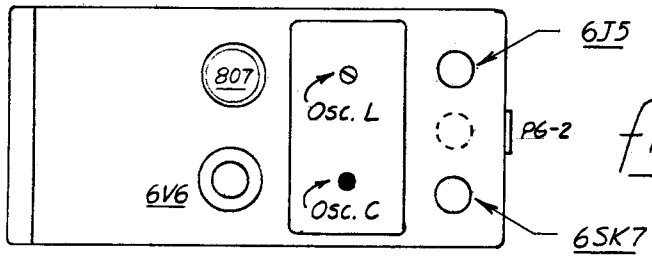

fig 1



TOP VIEW OF CHASSIS

fig 2

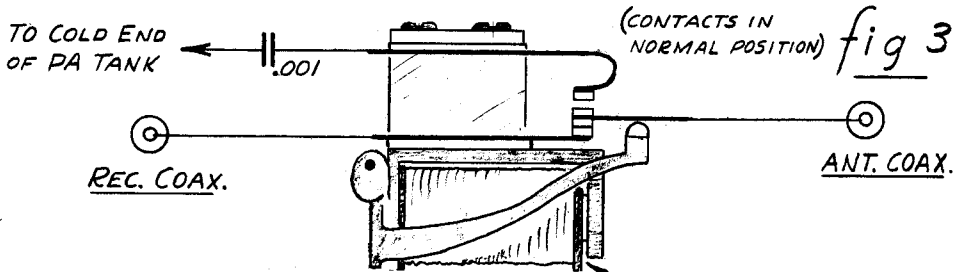

fig 3

MODIFIED ANTENNA RELAY

COIL IS REWOUND FULL OF #32 ENAMEL FOR 6V OPERATION.

COIL WINDING DATA

fig 4

- L-1 (1st doub. plate) 14Mc - 12 turns, #24 enamel, close wound on 5/8" dia. form.
- L-2 (2nd doub. plate) 28Mc - 7 turns, #20 enamel, space wound on 5/8" dia. form, length 3/8".
- L-3 (PA plate) 28Mc - 9 turns, #16 tinned, 1-1/4" long on 1" dia. form.
- RFC-1 (parasitic choke) - 7-1/2 turns, hook-up wire in plate lead, 1/4" dia. 1/2" long.

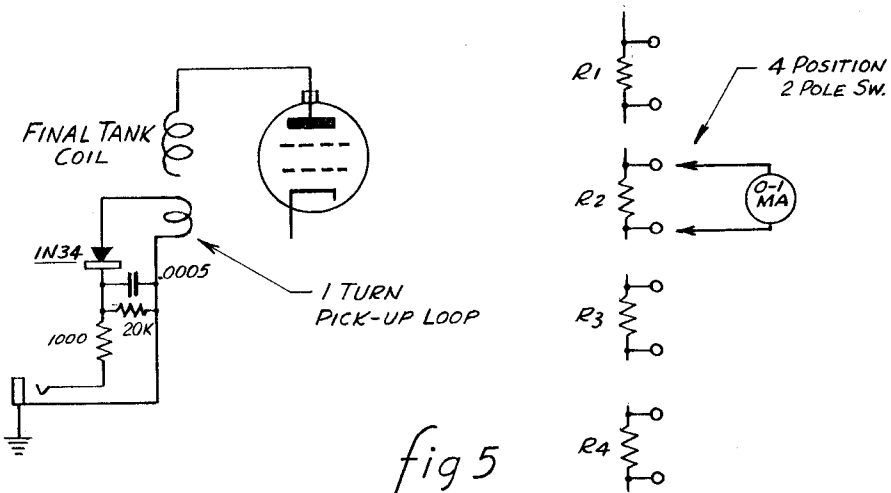

fig 5

VALUES FOR METER SHUNTS
DETERMINED FOR CIRCUIT
CONCERNED & METER USED.

CONTROL CIRCUITS FOR MOBILE TRANSMITTER

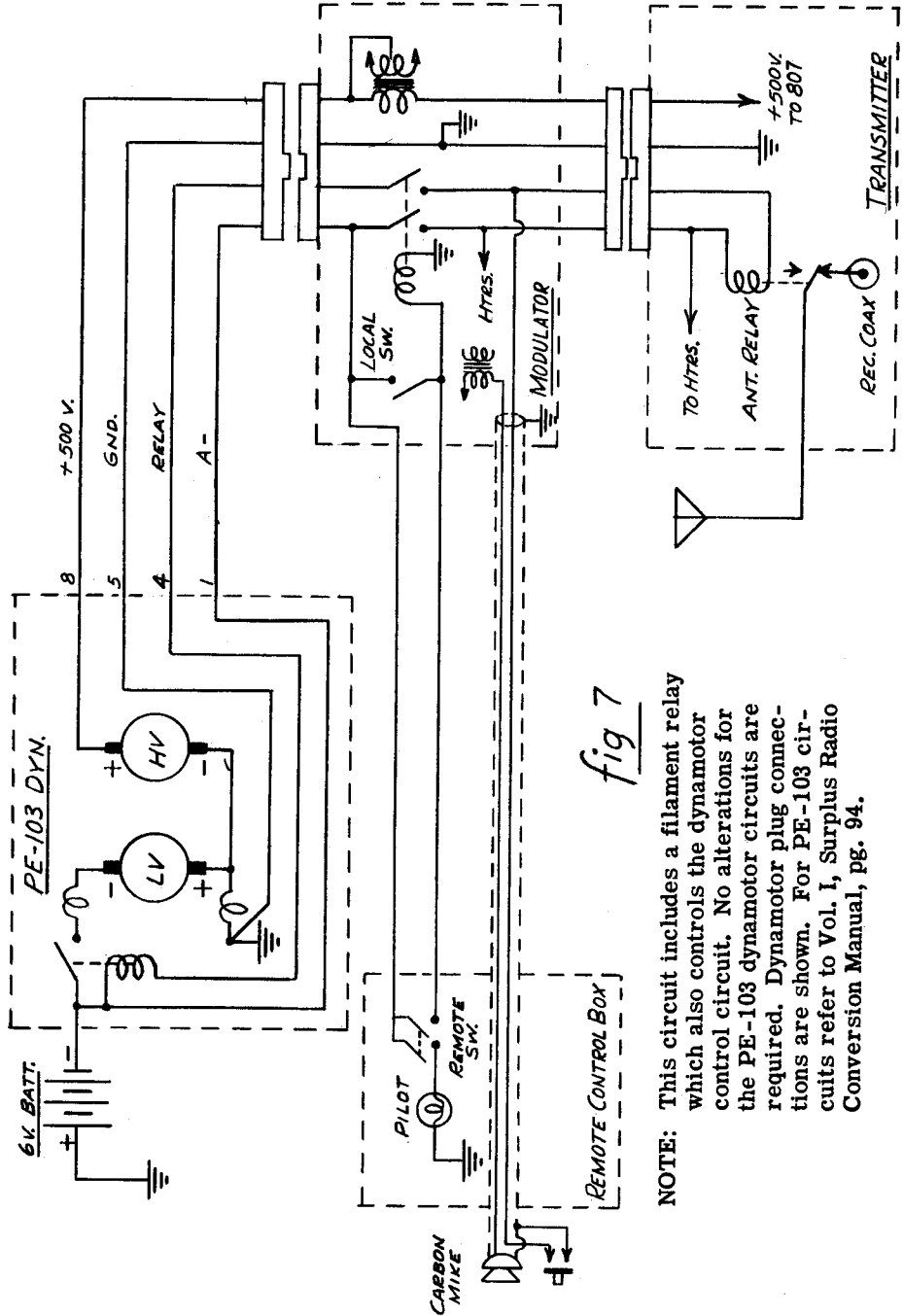
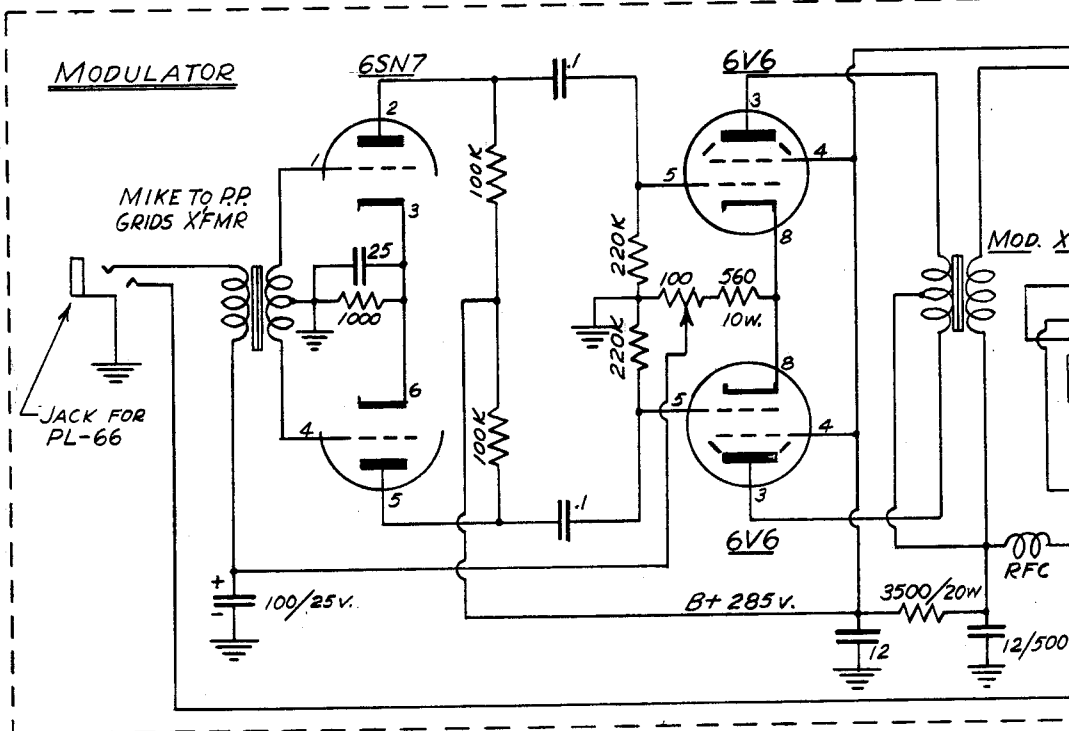
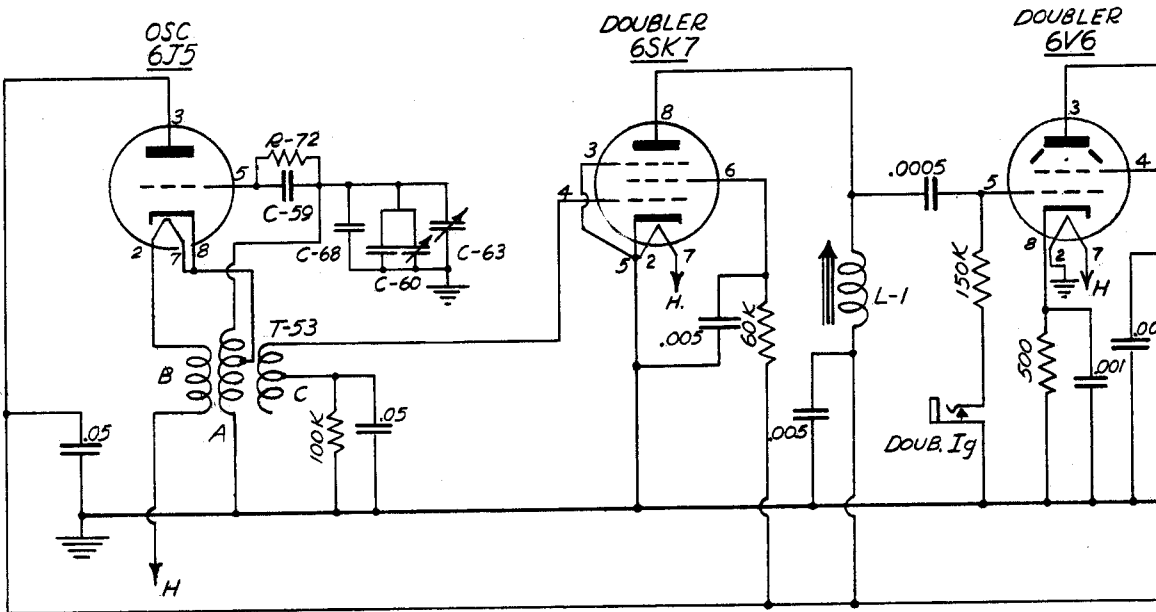

fig 7

NOTE: This circuit includes a filament relay which also controls the dynamotor control circuit. No alterations for the PE-103 dynamotor circuits are required. Dynamotor plug connections are shown. For PE-103 circuits refer to Vol. I, Surplus Radio Conversion Manual, pg. 94.

MODIFIED BC-459 X'MTR & MODULATOR



MODULATOR SCHEMATIC

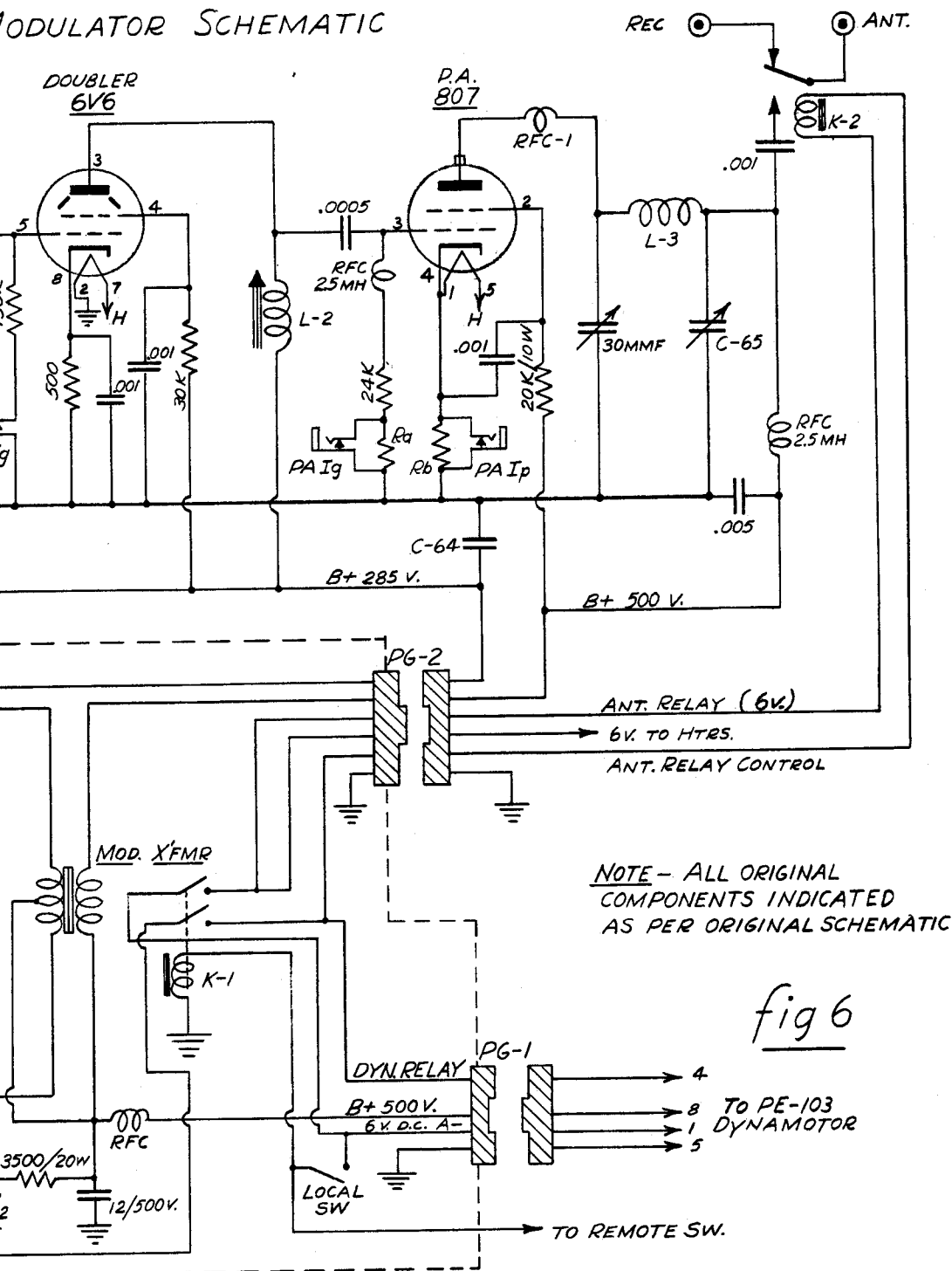

SCHEMATIC OF BC-459 TRANSMITTER (7-9.1 Mcs)

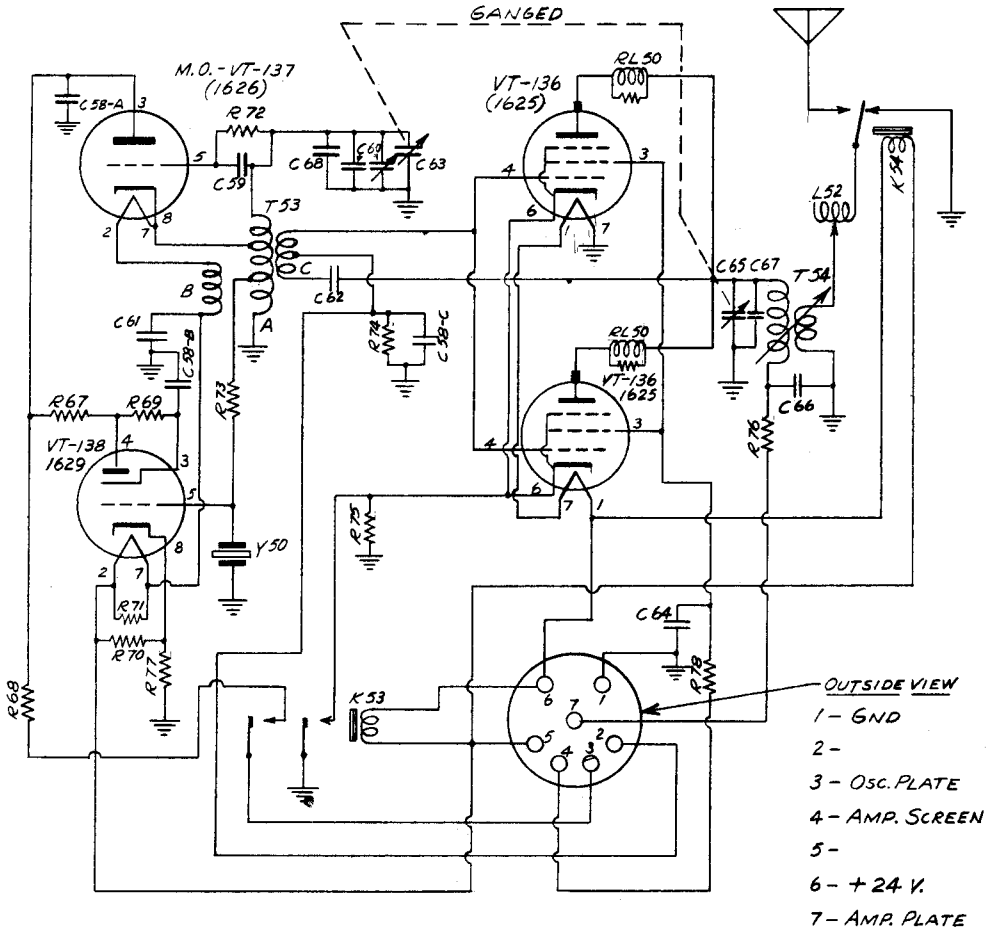

C58A, C58B, C58C - .05 uf
C59 - .00018 uf
C60 - Master Osc. padding
C61 - .006 uf
C62 - Fixed Neutralizing
C63 - Master Osc. tuning
C64 - .002 uf
C65 - P.A. tuning
C66 - .01 uf
C67 - P.A. padding
C68 - 3.0 uf
C69 - 50 uuf
K53 - Xmtr Selector Relay
K54 - Xmtr Output Relay

L52 - Ant. Loading Coil
R67, R72, R75 - 51,000 ohms
R68, R76 - 20 ohms
R69 - 1 Megohm
R70 - 1000 ohms
R71 - 126 ohms
R73, R74 - 15,000 ohms
R77 - 390 ohms
R78 - 51 ohms
RL-50 - Parasitic Suppressors
T53 - Oscillator Coils
T54 - Amplifier Coils
Y50 - Crystal Unit

fig 8

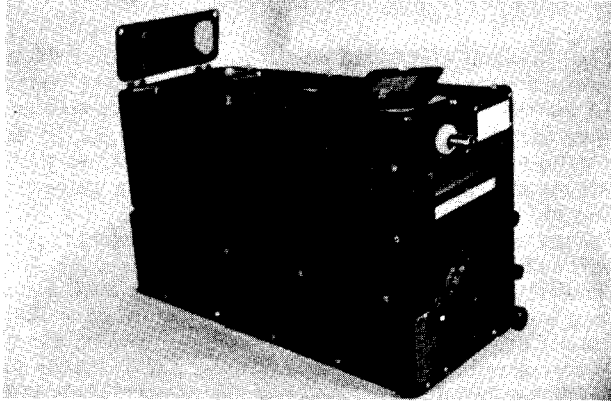

ORIGINAL ARC-5 TRANSMITTER

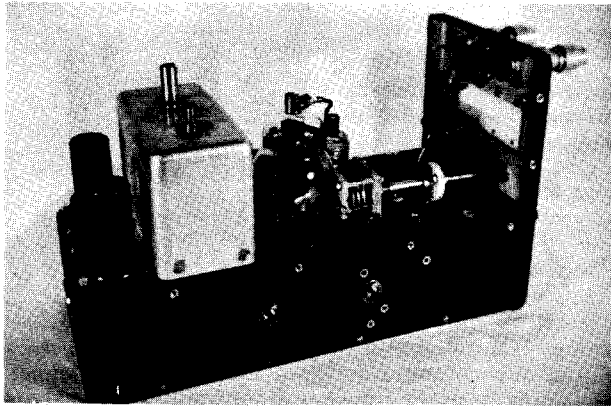

CONVERTED MOBILE TRANSMITTER

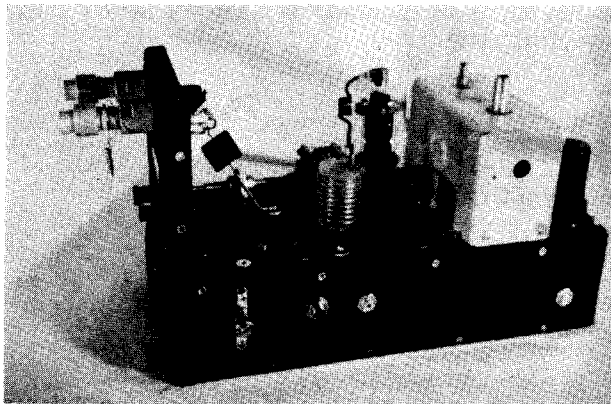

fig 9

SELENIUM-RECTIFIER POWER UNITS

A majority of the items of electronic equipment available on the surplus market are designed for operation in military aircraft. Hence, these items of equipment have been designed for the types of power supply available aboard such an aircraft. Three types of power supply have been standard; these are: 12-14 volts d.c., 24-28 volts d.c., and 115 volts a.c. at 400 cycles or 800 or 2400 cycles. It is impracticable to attempt to construct a high-frequency a-c supply for the operation of electronic equipment requiring such a source of power. It is better in such cases to construct a completely new power supply for the equipment and to design this power supply for operation from the standard 115-volt 60-cycle line.

Many of the items of surplus equipment are designed in such a manner that certain of the operating features and conveniences are lost when a 12-volt or 24-volt d-c power supply is not available for the unit. Relays, motors, band-changing systems and such conveniences must have a sizeable d-c power supply for their operation in many of the items of equipment. And if a d-c power supply is made available for these sections of the equipment it is often practicable and even less expensive to construct a slightly larger d-c power supply so that the plate-supply dynamotor and the tube heaters also may be operated from the d-c supply.

Typical 28-Volt Medium-
Current Selenium Rectifier.
(Vickers)

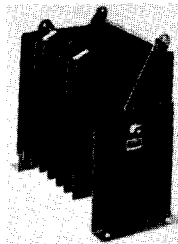

Features of the Selenium-Rectifier Power Supply:

The selenium-rectifier power supply for the production of low-voltage high-current d.c. is a completely reliable and quite satisfactory item of equipment. The efficiency of operation of such power supplies is quite good, running from 75 to 85 per cent at full load on the basis of output to input wattage. Regulation is adequate, running from three to five per cent from half-load to full-load current. The life of the rectifier unit is, for amateur use particularly, substantially unlimited; a standard unit running at rated load with normal cooling will show a loss of only a few per cent in output voltage after a 10,000-hour period of operation. The rectifiers deliver full output as soon as they are turned on and they are completely silent in operation since there are no moving parts.

Figure 1 - Forward and reverse current characteristics of a typical selenium-rectifier plate.

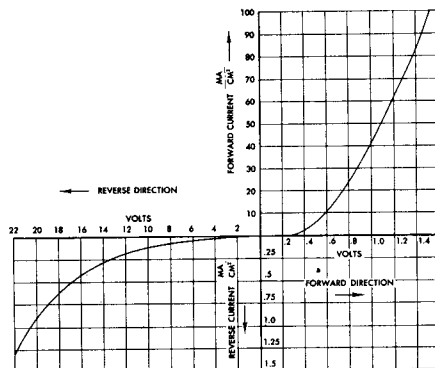

Design of Selenium-Rectifier Supplies:

Figure 1 shows the static forward and reverse current characteristics of a typical selenium rectifier plate. It can be seen that current flows much more readily in one direction than in the reverse direction. However, there is a moderate limit to the value of reverse voltage which may be applied to such a rectifier plate. The actual value of the maximum value of reverse r-m-s voltage which may be applied to each plate of a selenium rectifier depends upon the size of the plate and upon the maximum temperature at which the plate will be operated. Under ordinary conditions this maximum permissible reverse voltage varies from something over 20 volts for the small rectifier units used in a.c.-d.c. power supplies down to about 14 volts for the larger of the plates used in low-voltage high-current power supplies.

Figure 2 shows the dynamic voltage drop across each of the plates of each section of a selenium rectifier unit. A half-wave rectifier has only one section, a full-wave rectifier has two sections, and a bridge rectifier of the type used in low-voltage supplies has four sections. Rectifier units designed for an output voltage of 12 to 14 volts have only one rectifier unit for each of the four sections of the bridge rectifier, while units designed for 24 to 28 volts output have either two or three units in series in each of the sections. In the curves of figure 2 the number (1) represents the very smallest rectifier plate while (6) represents a relatively large plate of the type used where several amperes of output current will be required.

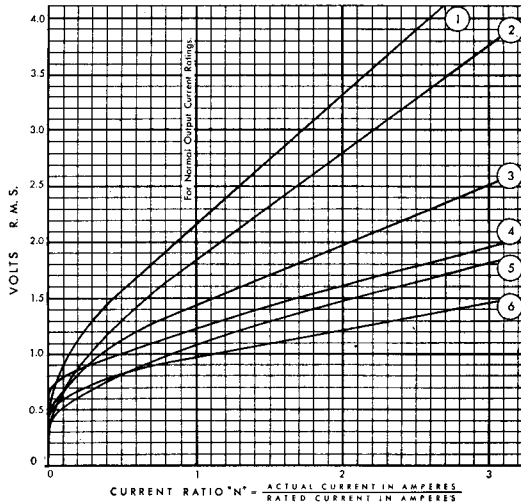

Figure 2 - Dynamic voltage-drop characteristics of six typical selenium-rectifier plates.

From figure 2 it can be seen that a voltage drop of approximately one volt for each plate connected in series in the effective current path within the power supply will be obtained at full load. Referring to the recommended circuit for a selenium-rectifier power supply, figure 3, it can be seen that the number of plates in series in the current path for a bridge rectifier is twice the number of plates in each section of the rectifier. And, with a choke-input power supply, the average output voltage of the rectified wave is 0.9 times the transformer secondary voltage. Hence, with a nominal 28-volt power supply as shown the output voltage will be 0.9 times

the transformer secondary voltage minus about 4 volts rectifier drop (assuming two plates per section in the rectifier) minus the resistance drop in the power transformer and the drop in the filter choke.

The power transformer which feeds the rectifier must have a current rating of at least 1.15 times the d-c output current which will be taken from the power supply. This comes about as a result of the fact that the r-m-s value of the alternating current wave which is fed to the rectifier is 1.15 times the average or d-c value of the rectified wave.

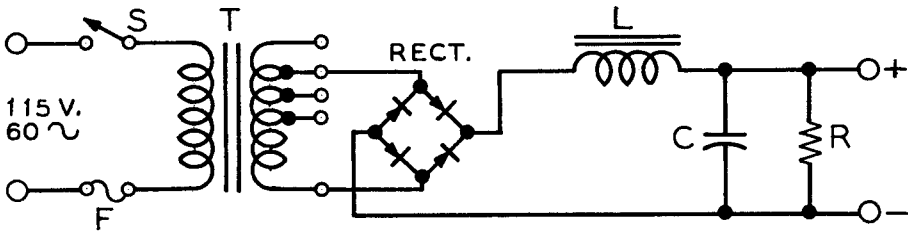

FIGURE 3

TYPICAL VALUES FOR A 28-VOLT, 10-AMPERE SUPPLY.

S - A.C. LINE SWITCH.

F - 5-AMPERE FUSE.

T - TAPPED 35, 36, 37, AND 38 VOLTS AT 12 A.

L - 0.025 HENRY, 10 AMPERES.

C - 2000 μ FD., 50 VOLTS.

R - 30 OHMS, 50-WATT BLEEDER RESISTOR.

RECT. - 10-AMPERE, 28-VOLT SELENIUM
BRIDGE RECTIFIER.

The use of a choke-input filter for the output of the selenium rectifier in a high-current power supply is to be preferred over the use of a filter capacitor directly across the output of the rectifier. With a capacitor-input filter across the output of the rectifier (in such cases a single capacitor is usually the only filter) the d-c output voltage will be somewhat higher, but the regulation will be much poorer and the r-m-s current through the rectifier will be approximately 1.2 times the d-c current being taken from the supply. With a choke-input power supply the d-c output voltage is as stated in the paragraph above, the regulation is good, and the r-m-s current through the rectifier is only 0.8 times the d-c output current of the power supply.

Filter chokes for low-voltage high-current power supplies are not so easily available as rectifiers. But a relatively small amount of inductance is required of such a choke. The minimum value of inductance required is determined through the use of the same formula as used in determining the value of the input choke for a conventional mercury-vapor-rectifier high-voltage power supply. $L = R_L/1000$. In this case R_L represents the smallest value of load resistance which will ever be used across the output of the power supply. If the power supply will sometimes be allowed to run without external load, R_L is the value of the bleeder resistor which will be used. However, if the power supply always will be operated with full load, R_L is equal to the output voltage of the power supply divided by the load current in amperes. The inductance required in a 10-ampere power supply will be found to

be in the region of 10 millihenries, depending upon the voltage and upon the minimum current which will be drawn. In most cases it will be found that the choke required by the formula stated above will be about the same in physical size as the choke which normally would be used in a conventional high-voltage power supply with the same power output rating.

The filter capacitor should have a capacitance of 100 to 5000 mfd. depending upon the load being placed upon the power supply and upon the degree of filtering required. However, in many cases and with many items of equipment neither a filter choke nor a filter capacitor will be required. In the power supplies for these items of equipment it is necessary only to connect the output of the rectifier to the input terminals of the equipment. In fact, if it is desired to get by with the bare minimum in the power supply it will be wise to attempt this procedure with the power supply for the equipment in question. If excessive hum or unsatisfactory operation is obtained the filter choke and capacitor may then be added.

The selenium rectifier should be mounted in such a manner that free air circulation is allowed. The rectifier plates are required to dissipate a moderate amount of heat by their operation. The units are designed in such a manner that normal convection currents of air flowing between the plates will accomplish the cooling. Under no conditions should the temperature of any of the plates in the selenium rectifier be permitted to exceed 75° Centigrade. If this temperature is exceeded, rapid deterioration of the plates may be expected. Selenium-rectifier stacks are designed in such a manner that under full load with an ambient (or inside-the housing) temperature of 35° C. the maximum safe operating temperature of the rectifier unit will not be exceeded.

THE ARC-5 VHF TRANSMITTER/RECEIVER

Most "surplus hounds" are well familiar with the popular ARC-5 series transmitters and receivers, but the VHF units of that series are not so well known. The ARC-5 VHF consists of the T-23/ARC-5 Transmitter and the R-28/ARC-5 Receiver, neither of which resembles the lower frequency ARC-5 units which are so common on the surplus market.

This article does not cover the actual conversion procedure, but merely gives information to assist the reader in converting the units as may seem necessary.

The transmitter and receiver are of the crystal-controlled variety, each using four crystals. Both can be set to operate on four channels throughout the range of 100-156 Mc. The units are designed exclusively for phone operation and also are intended only for operation from a remotely-controlled, push-button box.

The modulator (type MD-7/ARC-5) is a separate unit including a 28-volt DC dynamotor which furnishes voltages for the transmitter mounted on the same chassis. The 28-volt dynamotor which supplies voltages for the receiver is located on the rear of the receiver chassis.

The primary power requirements for operation are as follows:

Receiver only	28 volts DC at 2.0 amperes
Xmtr and Modulator (standby)	" " " " 2.7 "
Xmtr and Modulator (transmitting)	" " " " 9.5 "
Receiver, Xmtr and Modulator:	
(standby)	" " " " 4.7 "
(transmitting)	" " " " 11.5 "
(channel switching)	" " " " 6.9 "

Transmitter:

The T-23/ARC-5 transmitter weighs 12.3 lbs. and is 15-3/16 inches by 8-9/16 inches by 5-29/64 inches in physical size. It is normally plugged into a type MT-69/ARC-5 mounting rack.

The power output is from 6 to 10 watts into a 50-ohm antenna on any one of four frequencies within the following channels:

- A - 100-124 Mcs
- B - 122-146 "
- C - 122-146 "
- D - 132-156 "

The crystal frequency to be used for each channel is determined by the following formula:

$$\text{Crystal Frequency equals } \frac{\text{Carrier Frequency}}{18}$$

The Transmitter tube line up is as follows:

- V301 (1625) Crystal controlled harmonic oscillator
- V302 (1625) 1st harmonic generator
- V303 (832A) 2nd harmonic generator
- V304 (832A) Final PA

The power amplifier is plate and screen modulated by the separate MD-7/ARC-5 modulator and power unit.

Transmitter Tuning:

To tune the transmitter, allow the turret mechanism to come to rest on the channel desired and connect an external milliammeter from the terminals of J307 (on front of transmitter), to ground, according to the circuit being tuned. The tuning controls are labeled on Fig. 4 for easy reference. The following currents are normal:

Oscillator grid current	0.7 to 1.2 ma
1st harm. gen. grid	1.5 to 5.4 ma
2nd harm. gen. grid	1.5 to 5.4 ma
RF amplifier grid	1.2 to 4.8 ma
Plate voltage, final	550 volts

A listing is made here of relay functions in order to simplify the schematic diagrams.

K304	Controls motor
K301	Antenna relay
K302	Plate and screen voltage
K303	Modulator Screen and key control
K305	Aux. plate and screen voltage
K306	Modulator plate and voltage regulator interlock.

Receiver:

The R28/ARC-5 Receiver weighs 14.5 lbs. and is 14 by 7-5/32 by 4-7/8 inches in physical size. It is normally plugged into a type FT-220A mounting rack.

The circuit is a 10-tube superhet with no provision for BFO, as only voice reception is intended. The receiver will function on only four frequencies in the following channels, depending upon the crystals used:

A-	100-124 Mcs.
B-	122-146 "
C-	122-146 "
D-	132-156 "

The crystal frequency is determined by the following formula:

$$\text{Crystal Frequency equals } \frac{\text{Carrier Frequency} - 6.9 \text{ Mc.}}{24}$$

The Intermediate Frequency is 6.9 Mc. and the audio output impedance is 300 ohms, unless the BC-942A equalizer is used, which causes the output to be 4000 ohms.

The tube line up of the Receiver is as follows:

V101 (717A)	RF amplifier
V102 (717A)	Mixer
V103 (12SH7)	1st IF
V104 (12SH7)	2nd IF
V105 (12SL7)	Det-AVC-squelch
V106 (12SL7)	1st AF and squelch amp.
V107 (12A6)	2nd AF
V108 (12SH7)	RF osc - 4th harmonic generator
V109 (717A)	Tripler - 12th harmonic generator
V110 (717A)	Doubler - 24th harmonic generator

For information, the plug connections on the receiver are as follows:

Rear plug (J102)

- 1- Ground
- 2- Audio output (hi or low)
- 3- MVC gain control lead
- 4- AVC-MVC control lead
- 5- Blank
- 6- 28 volts (in)
- 7- "B" plus (out)

Front plug (J103)

- 1- Channel A control
- 2- Channel B control
- 3- Ground
- 4- Channel C control
- 5- Channel D control
- 6- Blank

To operate the receiver alone, short terminals 1 and 6 of the rear plug to start the dynamotor, and place a 50,000-ohm pot. to ground from terminal 3 to function as an RF gain control.

A schematic drawing of the FT-220A Rack is given in Fig. 5.

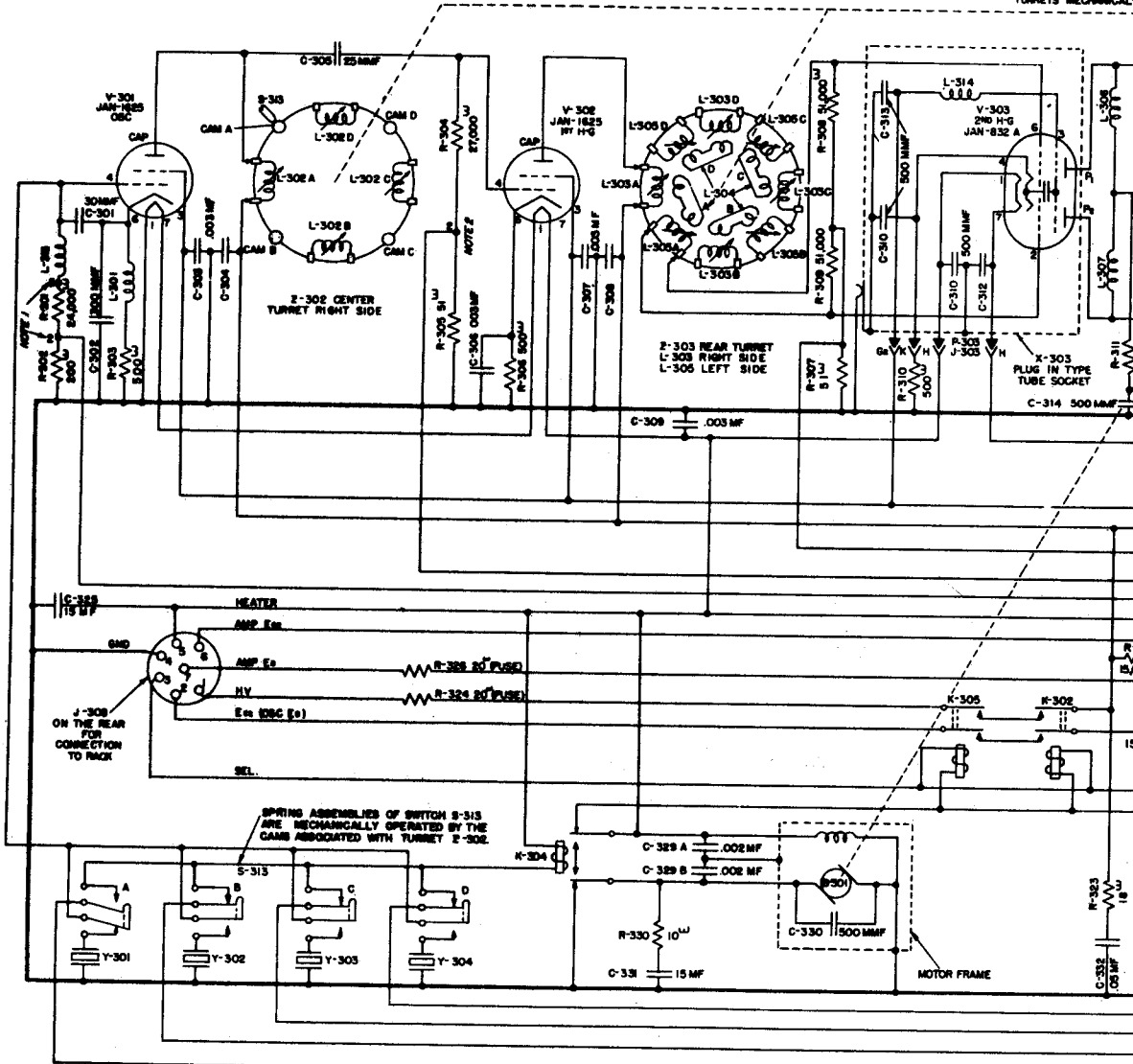

TURRETS MECHANICALLY DRIVEN BY MOTOR B-301

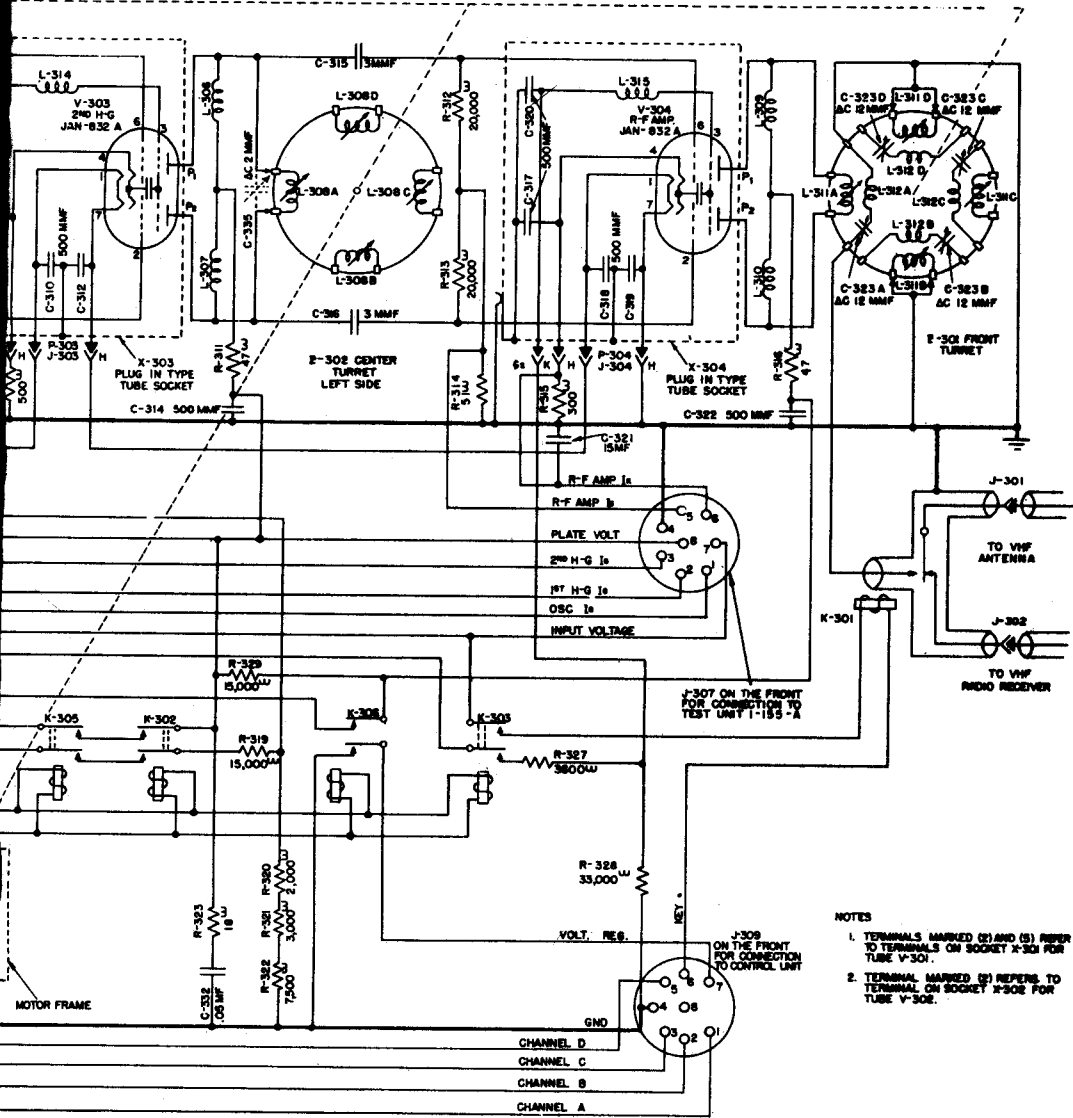

- NOTES
1. TERMINALS MARKED (2) AND (3) REFER TO TERMINALS ON SOCKET X-303 FOR TUBE V-301.
 2. TERMINAL MARKED (2) REFERS TO TERMINAL ON SOCKET R-302 FOR TUBE V-302.

FIG. 1 - ARC-5 VHF TRANSMITTER (Original Schematic)

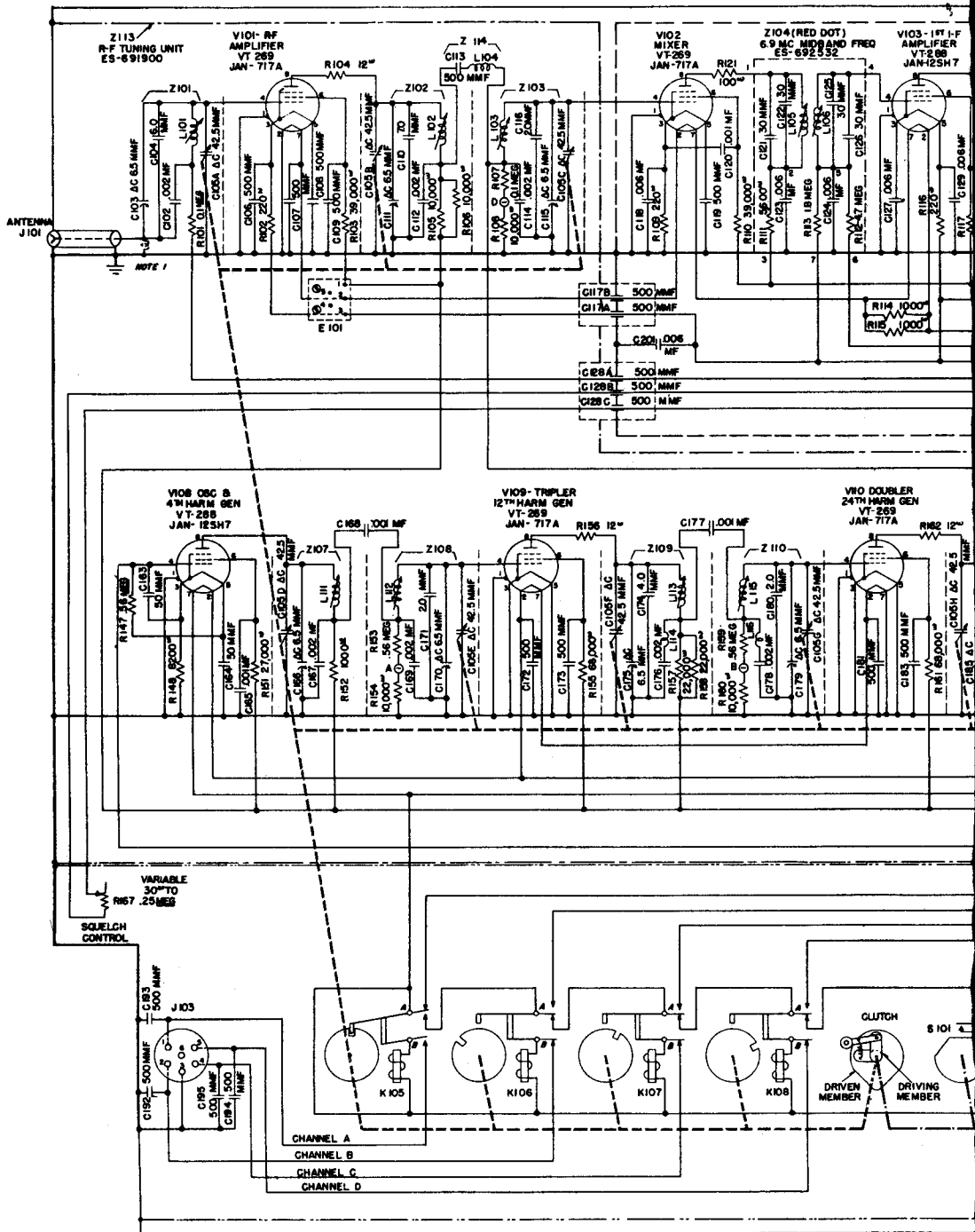
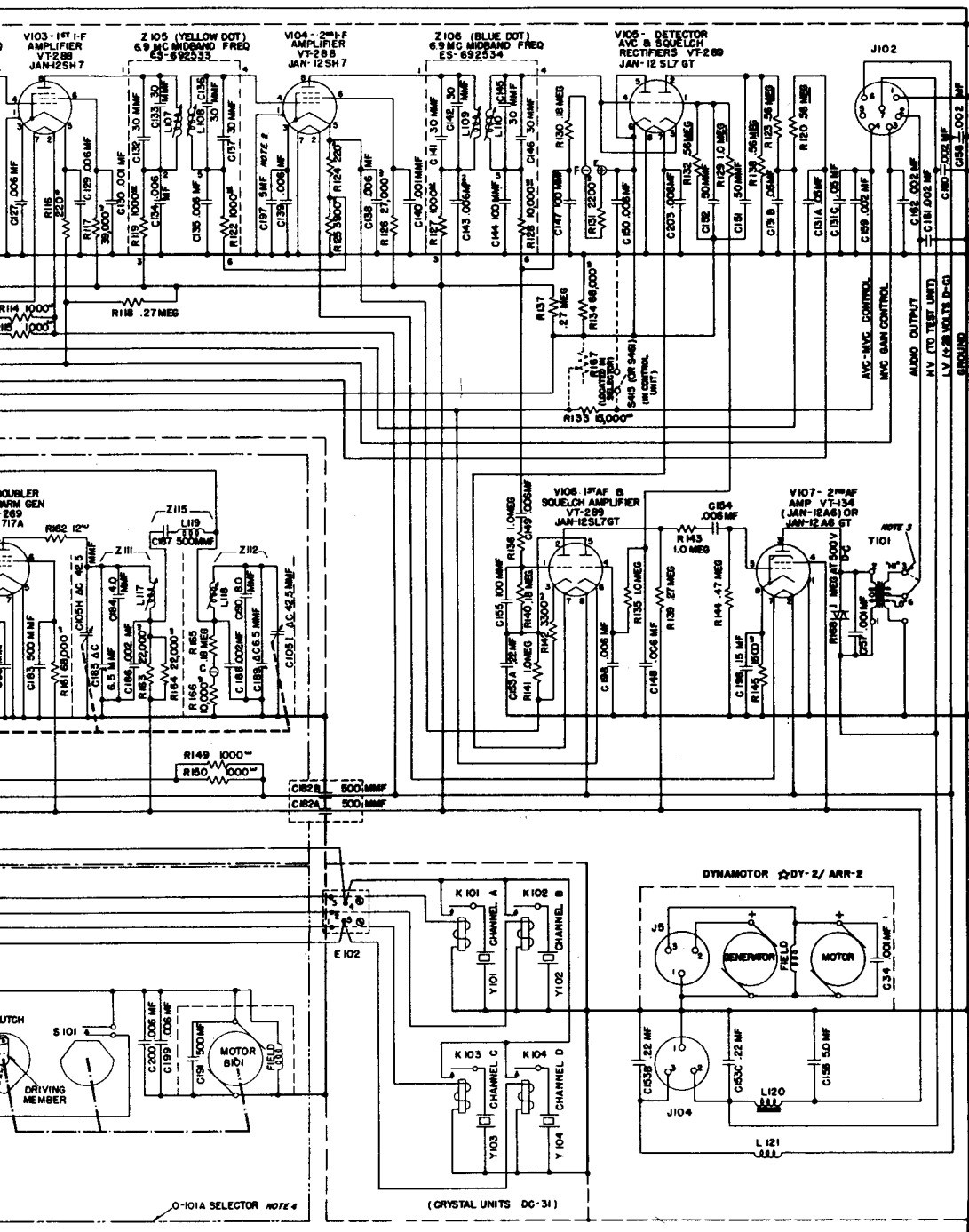
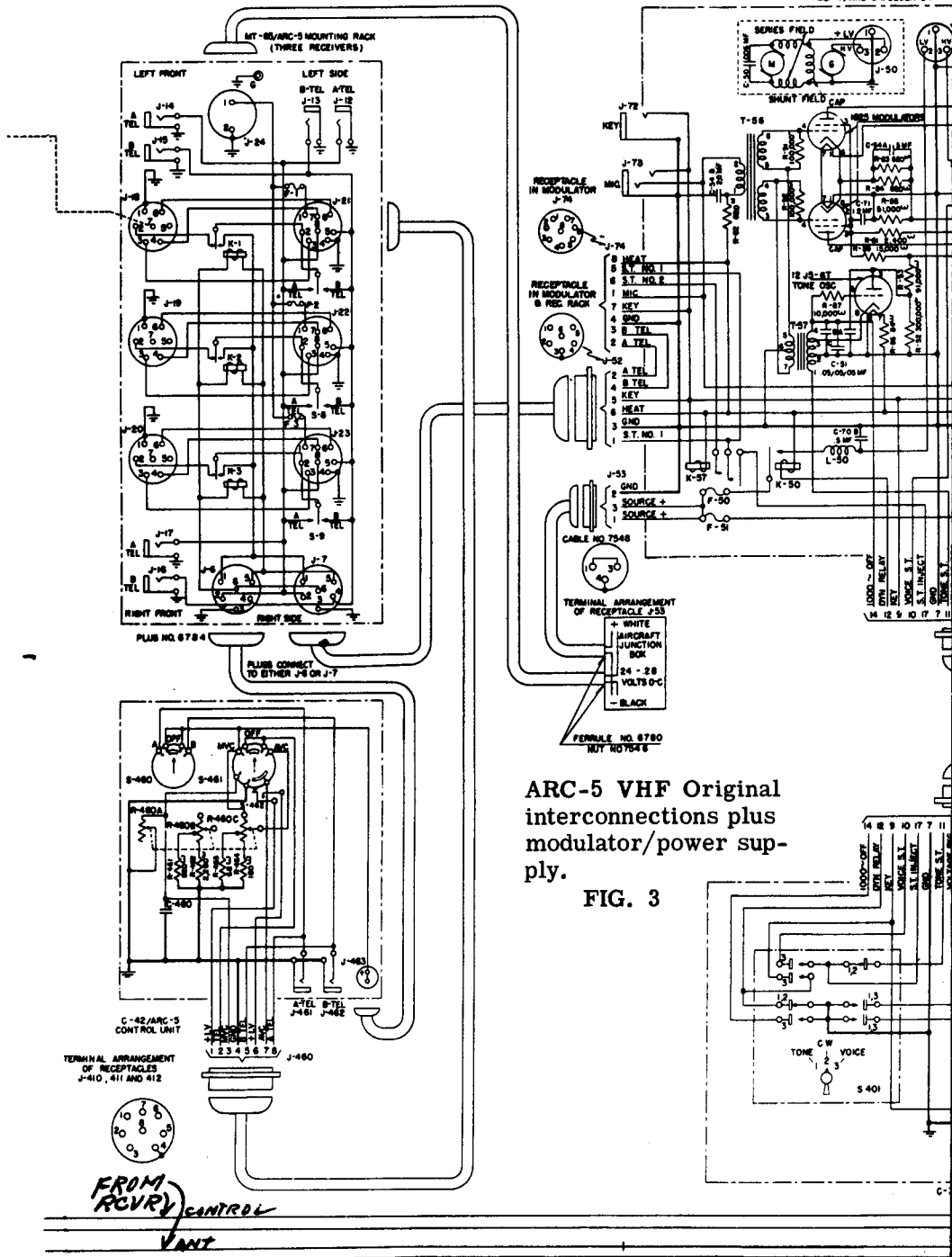
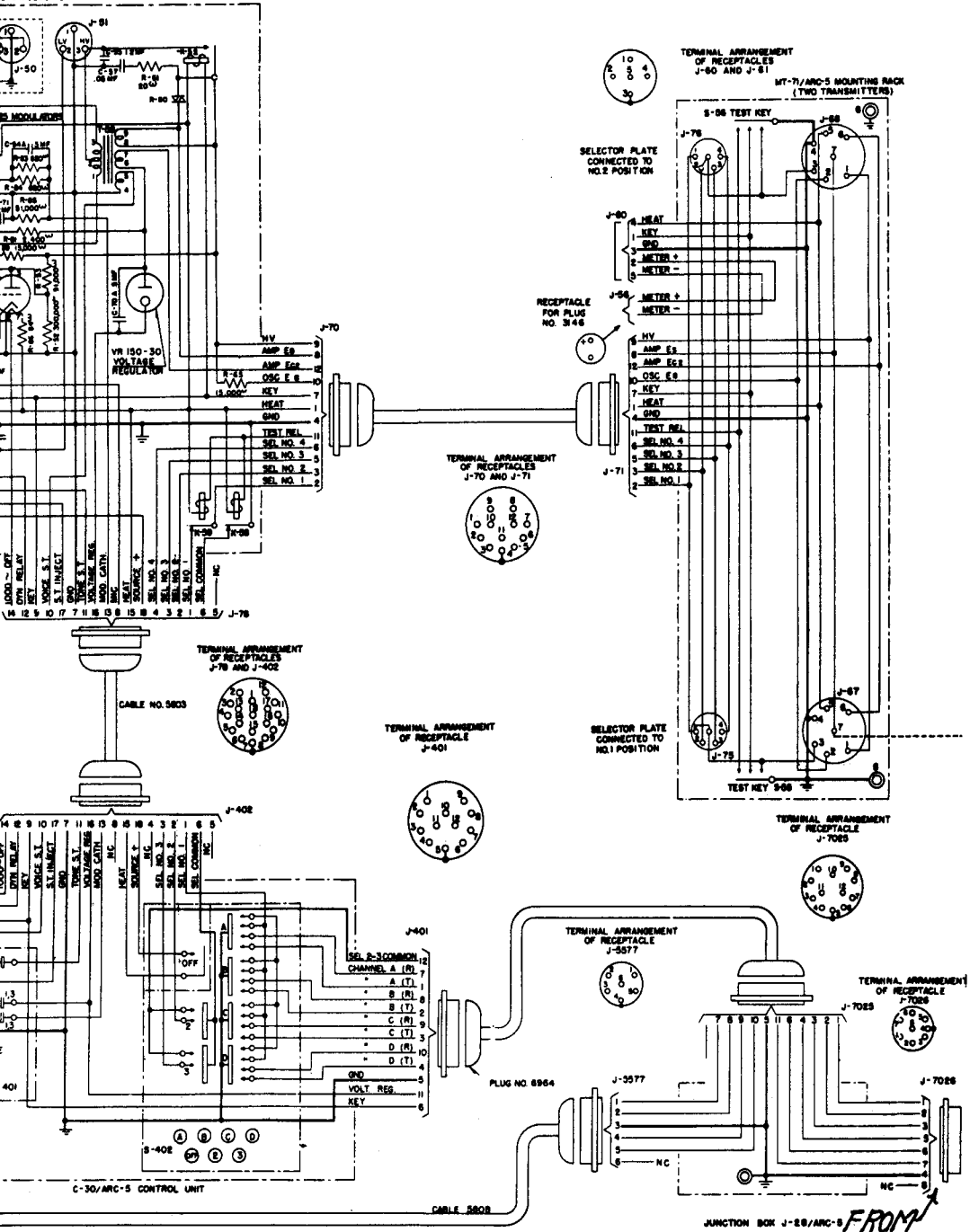

FIG. 2 - ARC-5 VHF RECEIV



RECEIVER (Original Schematic)





ARC-5 VHF TRANSMITTER TUNING

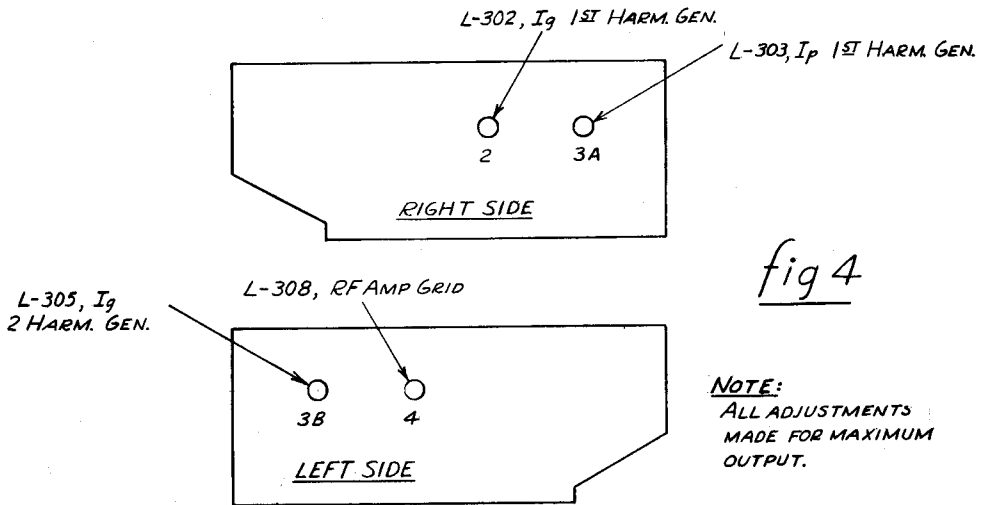
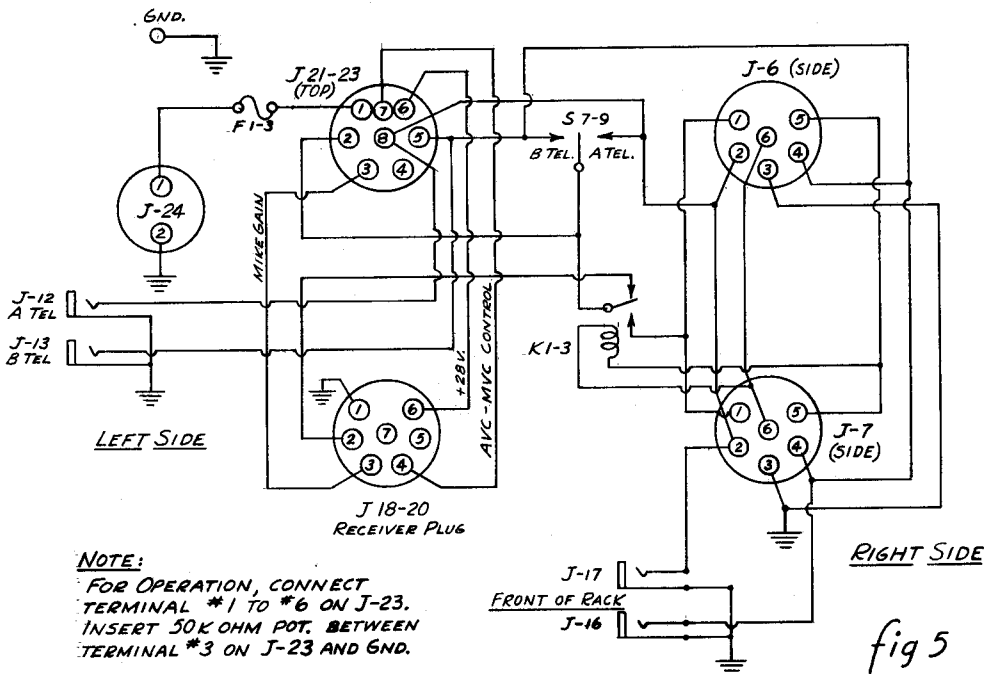

fig 4

NOTE:
ALL ADJUSTMENTS
MADE FOR MAXIMUM
OUTPUT.

FT-220A MOUNTING RACK SCHEMATIC



NOTE:
FOR OPERATION, CONNECT
TERMINAL #1 TO #6 ON J-23.
INSERT 50K OHM POT. BETWEEN
TERMINAL #3 ON J-23 AND GND.

fig 5

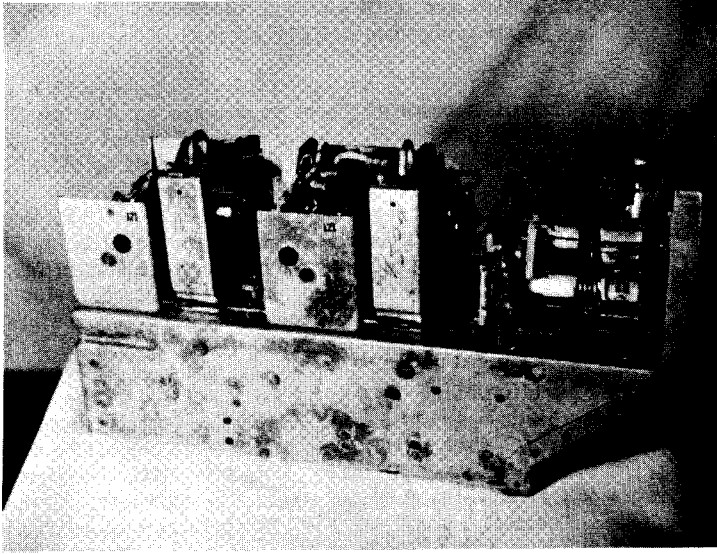

ARC-5 VHF TRANSMITTER (Cover Off)

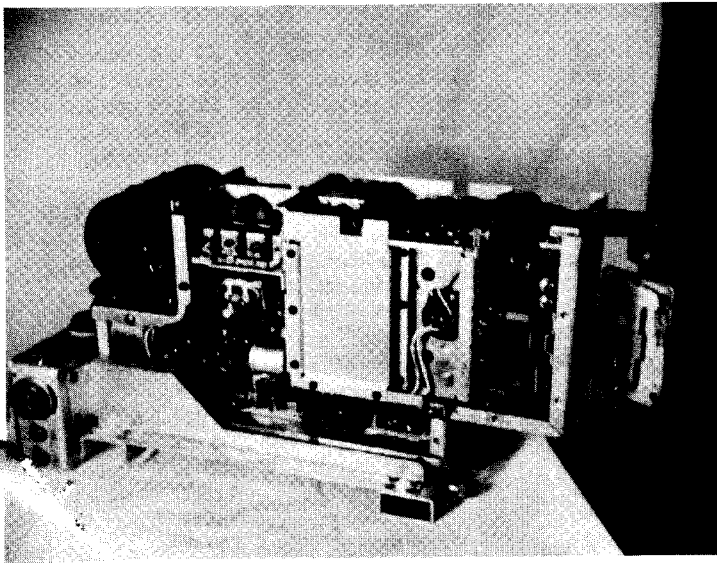

ARC-5 VHF RECEIVER (Cover Off)

FIG. 6

CONVERSION OF THE GO-9 TRANSMITTER
(Also applicable to TBW series)

The model GO-9 Aircraft transmitter was manufactured for the United States Navy and used primarily in the larger Naval aircraft for CW and MCW transmission with a nominal power output of 100 watts. The complete unit is quite adaptable to amateur use as it covers directly the 20, 40 and 80 meter bands.

It is to be noted here that another popular surplus transmitter, the "TBW", is quite similar to the GO-9. The TBW is also Naval equipment, being designed for advance-base installations. The general appearance is somewhat different, but the same three-section construction is used. Two major differences exist between the models: First, the TBW intermediate frequency section covers a slightly different range (350 to 1000kc.); second, the TBW incorporates an 843 tube as a class A suppressor-grid modulator.

The high-frequency section of the TBW is identical to that of the GO-9 in regard to the basic circuit, and the power unit is similar. The instructions to follow may be generally used for the TBW, but as this conversion data pertains primarily to the GO-9 transmitter, certain sections will not apply to the TBW. Particular attention should be paid to the difference in terminal connection numbers in relation to the power supply section. Naturally, since the TBW has its original modulator, the one described for the GO-9 will not be necessary.

The assembly consists of three aluminum frames fastened together with snap catches and guide pins to operate as a single unit. All of the necessary connections between units are made by contact brushes and contacts.

The three units and their specifications pertaining to the GO-9 and TBW follow:

<u>IF Transmitter</u>	<u>GO-9</u> Type CAY 52192	<u>TBW</u> Type CAY 52238
Size: Height	33 31/32 inches	33 1/4 inches
Width	10 1/2 inches	13 5/8 inches
Depth	16 3/8 inches	17 1/4 inches
Weight	44 lbs.	76.5 lbs.
Frequency	300-600 kc.	350-1000 kc.
<u>HF Transmitter</u>	Type CAY 52193	Type CAY 52239
Size: Height	33 31/32 inches	33 1/4 inches
Width	10 1/2 inches	13 5/8 inches
Depth	16 3/8 inches	17 1/4 inches
Weight	47.5 lbs.	84 lbs.
Frequency	3000-18,000 kc.	3000-18,000 kc.
<u>Rectifier Unit</u>	Type CAY 20103	Type CAY 20084 (includes Modulator)
Size: Height	33 31/32 inches	33 1/4 inches
Width	7 3/8 inches	10 7/16 inches
Depth	16 3/8 inches	17 1/4 inches
Weight	40.5 lbs.	71 lbs.

Tube Line Up (Same for both GO-9 and TBW with exception of an additional 843 modulator in TBW.)

IF Transmitter 1 type 801 Master Oscillator
 1 type 807 IF Amplifier
 1 type 803 Power Amplifier

HF Transmitter	1 type 837 Master Osc. (ECO)
	1 type 837 Doubler
	1 type 803 Power Amplifier
Rectifier Unit	1 type 5Z3 Low volt. Rectifier (500 v. at 200 ma.)
	2 type 1616 High volt. Rect. (2000 v. at 175 ma.)
	1 type 843 modulator (in TBW only)

Adding a 10-Meter Doubler and PA Section:

Since the Intermediate Frequency Transmitter covers the range of 300-600 kc. (350-1000 in TBW), it is of no use to the amateur and can be converted into a 10-meter section.

The regular oscillator in the high-frequency section will tune to 20 meters directly, thus the only requirement for 10-meter operation is a doubler and power amplifier circuit which will operate efficiently on 10-meters.

The IF section is stripped of all wiring and components with the exception of the terminal strips and the 807 tube socket and mounting. (Refer to Fig. 1 for original parts to be reused and left intact.) The circuit in Fig. 1 is now constructed and wired into the bottom compartment of this section.

The bias supply is also constructed and mounted in this bottom compartment. It should be kept clear of the 10-meter section.

Excitation for the 10-meter section is obtained through a coax. line which couples to the plate of V302 (807) through a 50 uufd. condenser. It may be desirable to use an 813 in place of the 4E27, depending upon availability. The two tubes will give nearly identical results. A 1625 type tube may be used in place of V302 (807); however, the different filament voltage requirements and the different socket must be taken into consideration.

Coil Data: (10 Meter Added Section)

The 807 plate coil consists of a standard B&W coil (50 watt) for 10-meters or an equivalent coil.

The 4E27 grid coil consists of 7 to 9 turns on a 1" form, space wound 1-1/2 inches long.

The 10-meter final tank coil is air wound, 4 turns of No. 8 wire.

A 3-turn loop will serve to couple the antenna to the final if 300-ohm twin-lead line is used. One turn should be interwound with one turn on the cold end of the final tank coil.

Note that terminal numbers are given on the diagram for HV and LV connections. These should be followed exactly, as the power supply to be constructed later will agree with these terminal connections. TBW terminals will not agree with those on the diagram and comparison should be made between the two original schematics for proper connections.

The 4E27 has its filament supply removed when the other bands are being used and thus does not cause interference. Note that a 1-ohm slide wire resistor is used in the 4E27 filament circuit. This should be adjusted for the 5 volts required at the 4E27 socket. The active portion of this resistor will be required to dissipate about 38 watts.

A resonance indicator is shown on the diagram in the 10-meter final circuit, making use of an RF meter which was part of the original circuit. The shortest leads possible should be used in this part of the circuit, due to the heavy currents involved. In constructing the 10-meter section, great care should be taken to isolate all grid circuits from the plate circuits.

High Frequency Section:

No changes are necessary in the HF section, but a few suggestions will be made here for improved performance. The type 803 tube originally used in the PA stage may be replaced directly with an 813 (socket must be changed). An RFC choke coil should be inserted in series with the HV lead to the final tank coil. The grid resistor of the 803 is lifted from ground and run directly to terminal 17 as part of the keying circuit to be installed later.

Power Supply Section:

As the original rectifier unit operated from a 600-800 cycle source, it will be necessary to revamp this unit for 60-cycle operation. The 600-800 cycle transformers must be replaced with standard 60-cycle equipment. The 60-cycle transformers will naturally be much larger and will necessitate rearrangement of the shelves and parts in this unit. The shelves are removable and may be replaced in the position most suitable for the parts used. All relays in the unit should be taken out to give additional space, but the normal circuits through these relays must remain unchanged. Jumpers or new wiring should be used to complete the circuit as each relay is removed. The revamped power supply should be wired in accordance with Fig. 2, making use of the original parts as noted.

Keying Circuit:

The original primary-keying circuit made use of the 12-24 volt relays in the equipment, which have been removed. A grid-block keying system is included as part of the revision. This circuit will provide positive keying of the transmitter. A key-click filter is shown in the diagram. One item of importance is that the grid resistor of the 803 in the HF section is lifted from ground and run directly to terminal 17, in order that all tubes in the transmitter will be blocked.

Modulator:

Since the GO-9 was designed only for CW or MCW operation, a modulator will have to be added for voice use. This would be a very large unit if the normal plate modulation system were used; since there is no space in the transmitter for such a unit, a reactance type NFM modulator is used as shown in Fig. 3. If desired, the 803 in the final stage of the medium-frequency transmitter of the GO-9 may be suppressor-grid modulated by using a circuit similar to that used in the TBW.

This unit is built on a small chassis mounted in the bottom of the HF section and coupled to the ECO unit as indicated on the diagram. The gain control and mike jack may be brought out to the front panel of the HF unit. Voltage for the modulator may be taken from any convenient place, preferably from a tap on R305-306. But for best performance a small voltage regulated supply should be built and installed where practical.

"10-METER" SECTION FOR THE GO-9

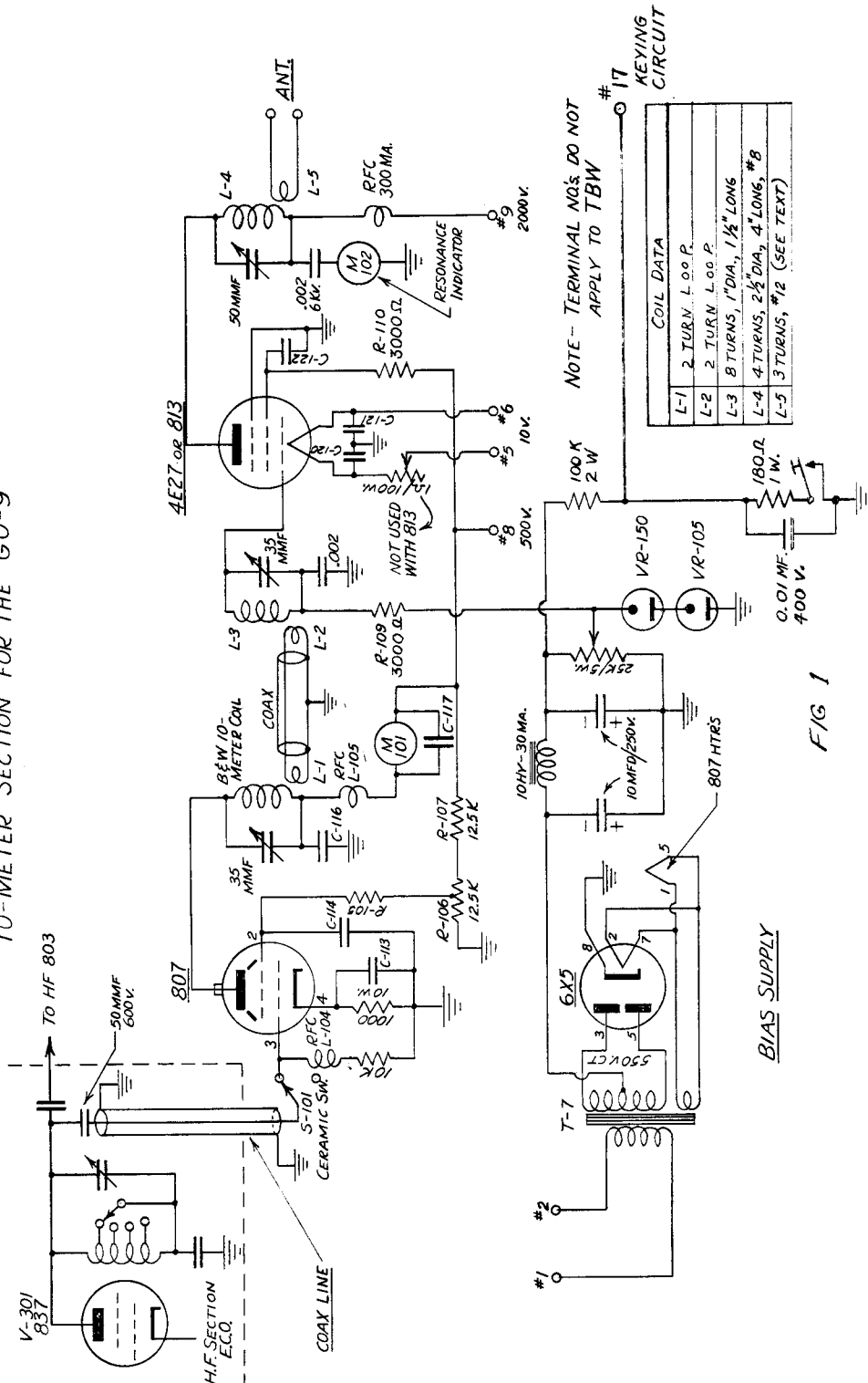

FIG 1

BIAS SUPPLY

POWER SUPPLY FOR THE GO-9 TRANSMITTER

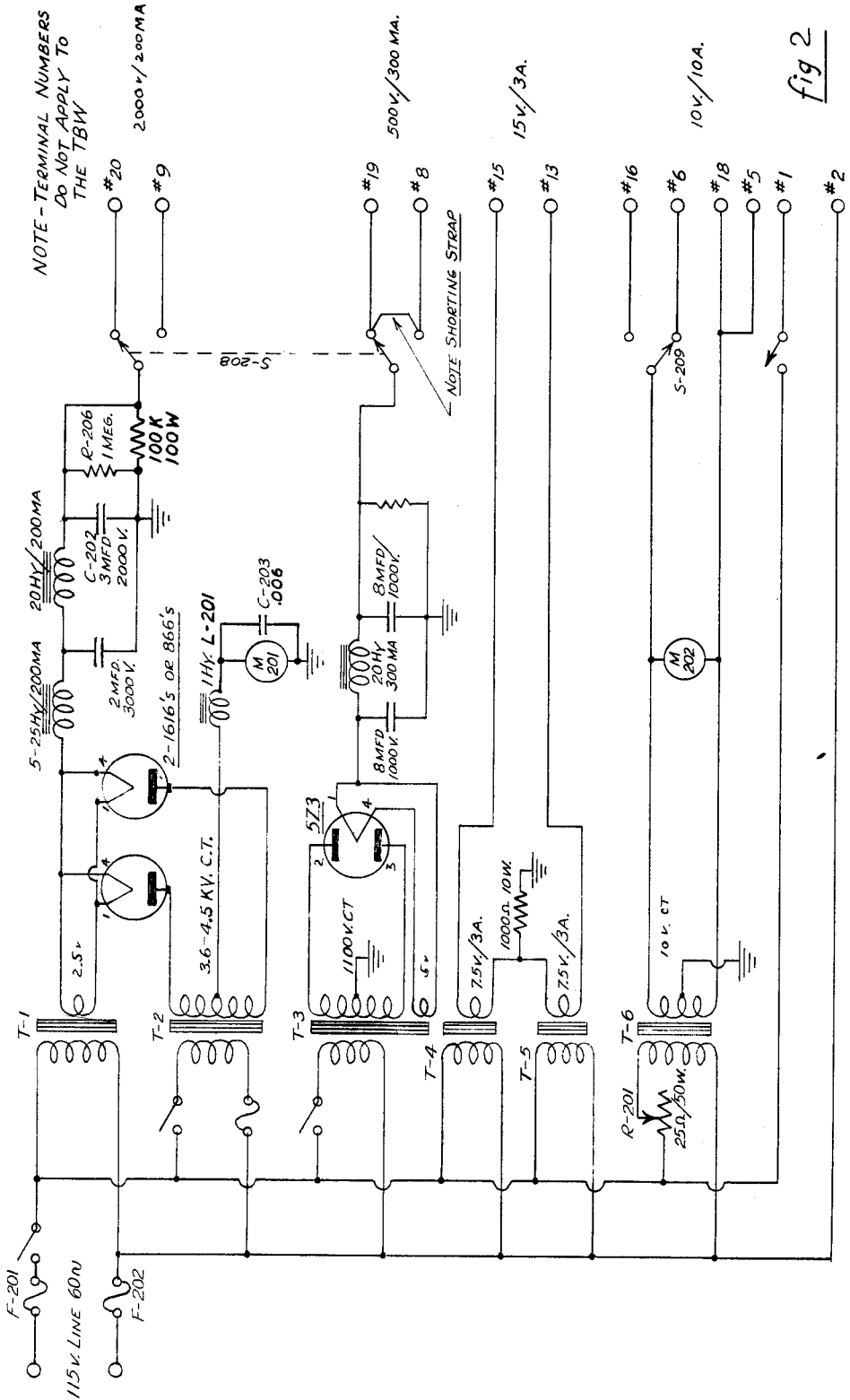
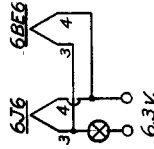
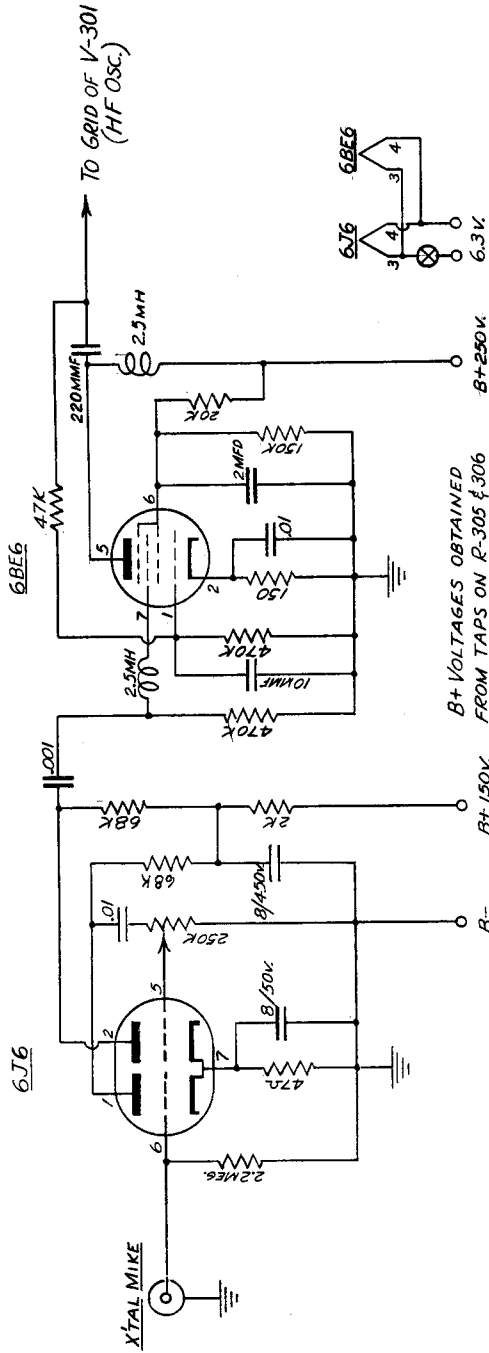
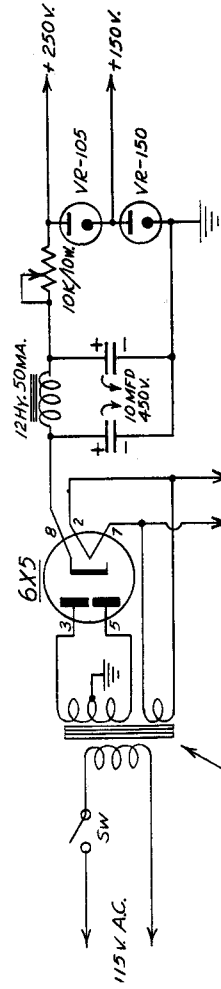

fig 2

NBFM REACTANCE MODULATOR FOR THE GO-9



B+ VOLTAGES OBTAINED FROM TAPS ON P-305 & 306



REGULATED POWER SUPPLY FOR NBFM MODULATOR (OPTIONAL)

POWER YEMP 50MA., 550V. CT

fig 3

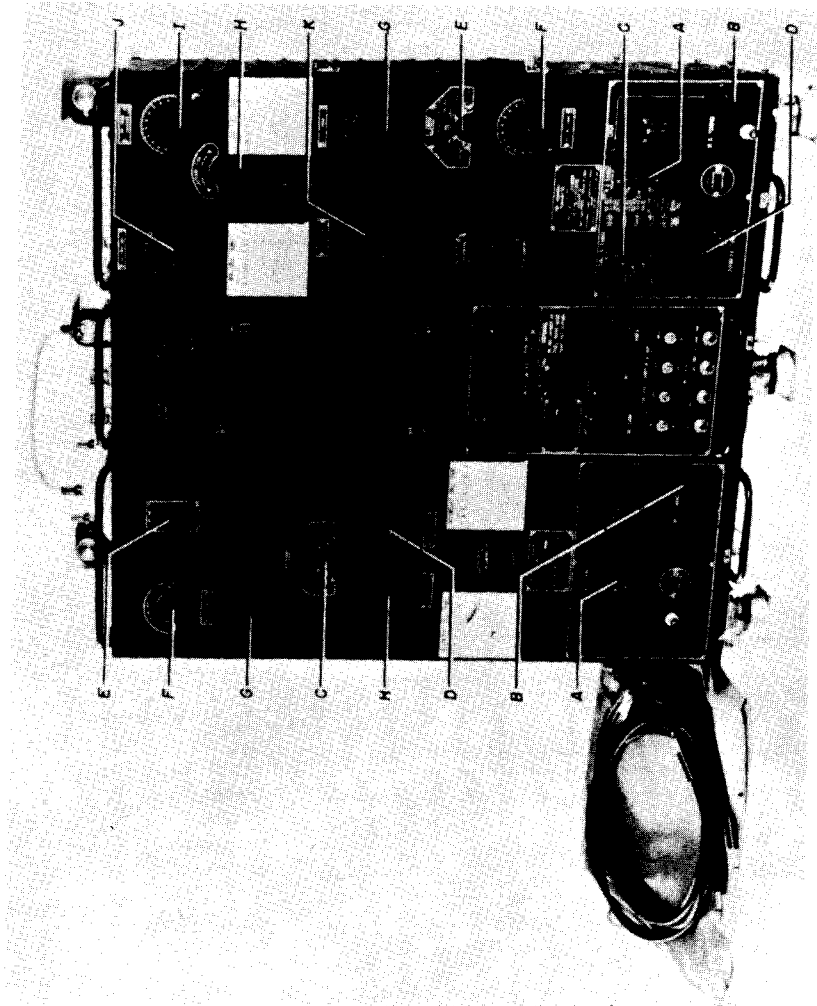

GO-9 TRANSMITTER

H. F. TRANSMITTER

RECTIFIER UNIT

L. F. TRANSMITTER

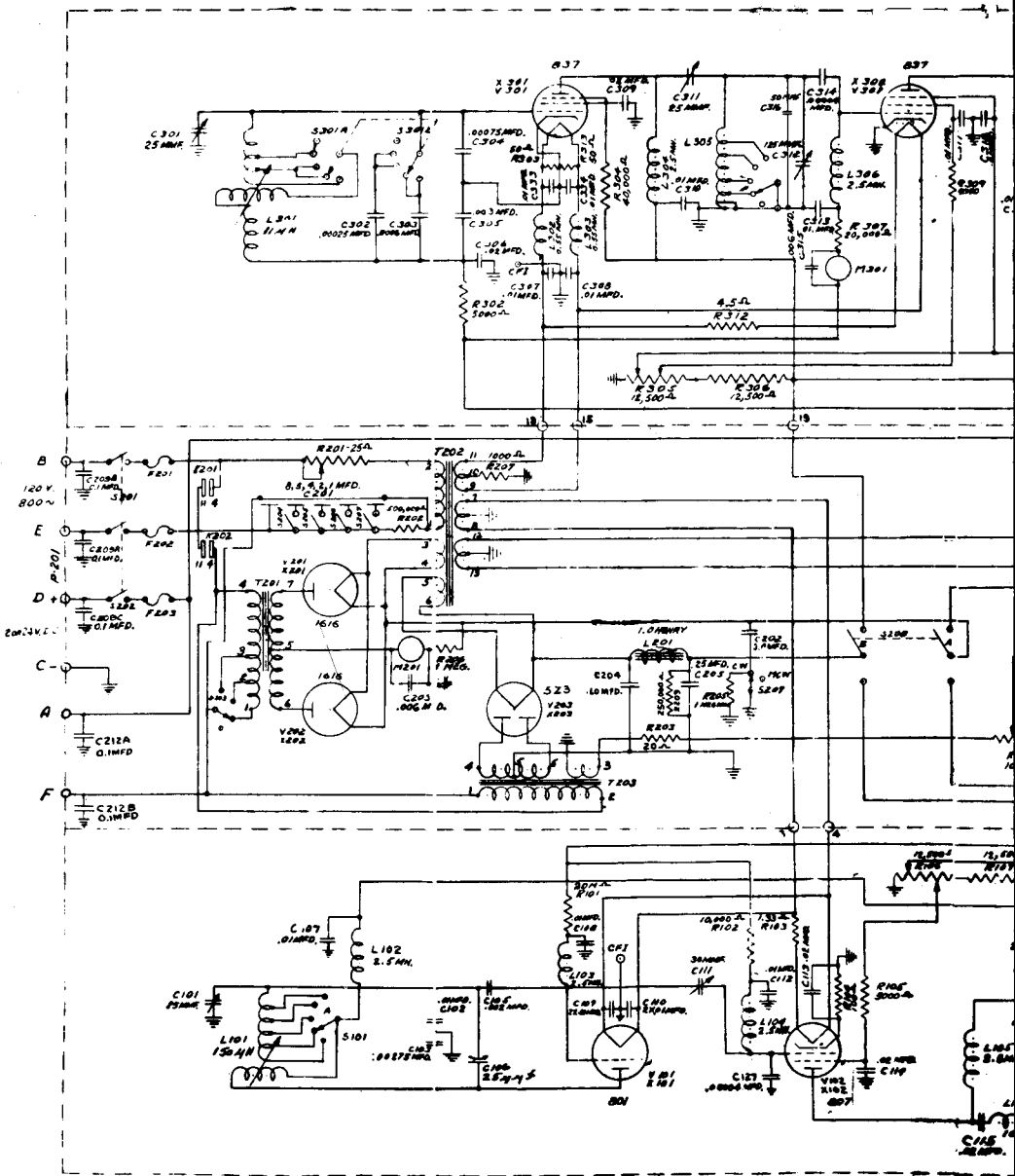

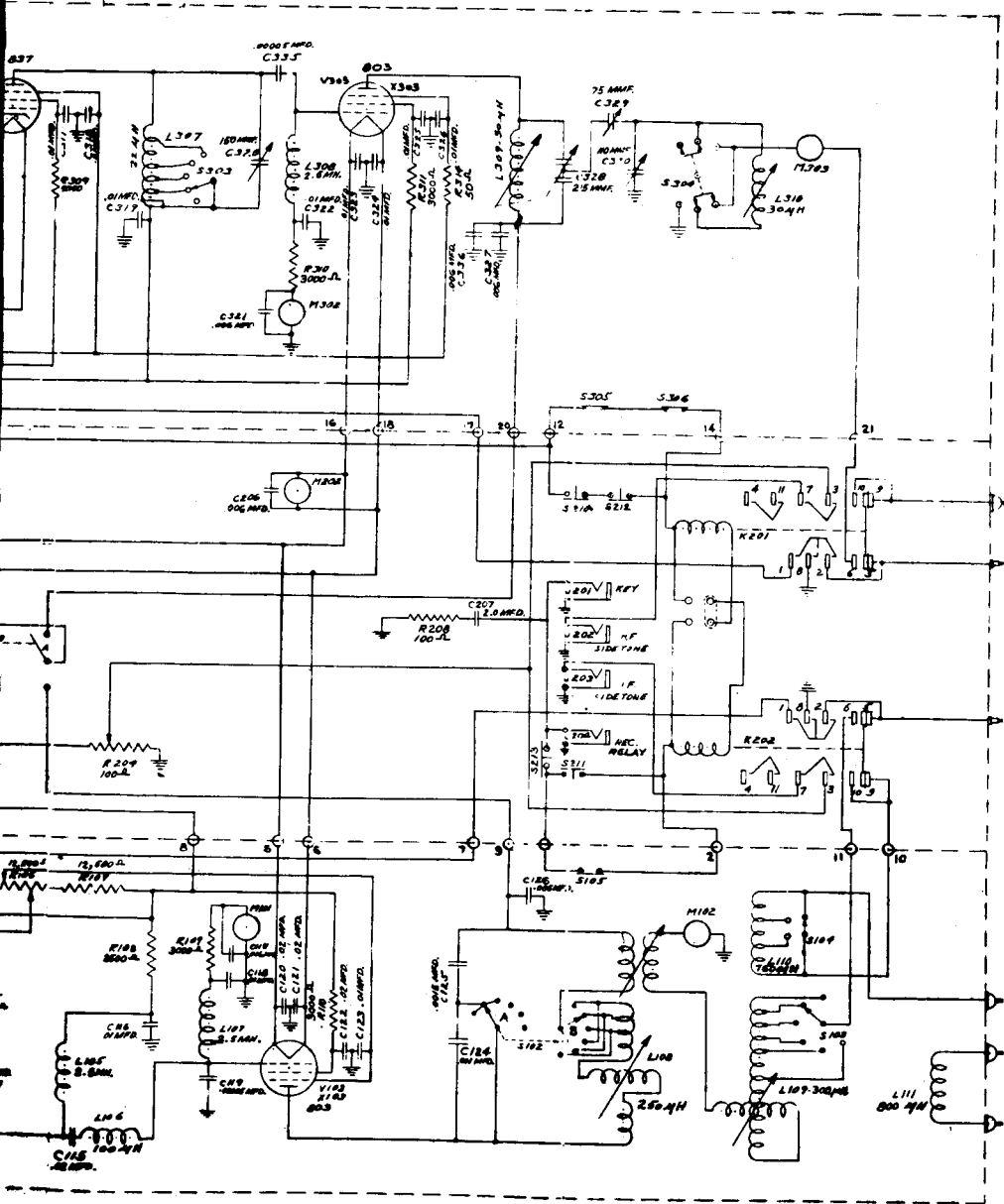
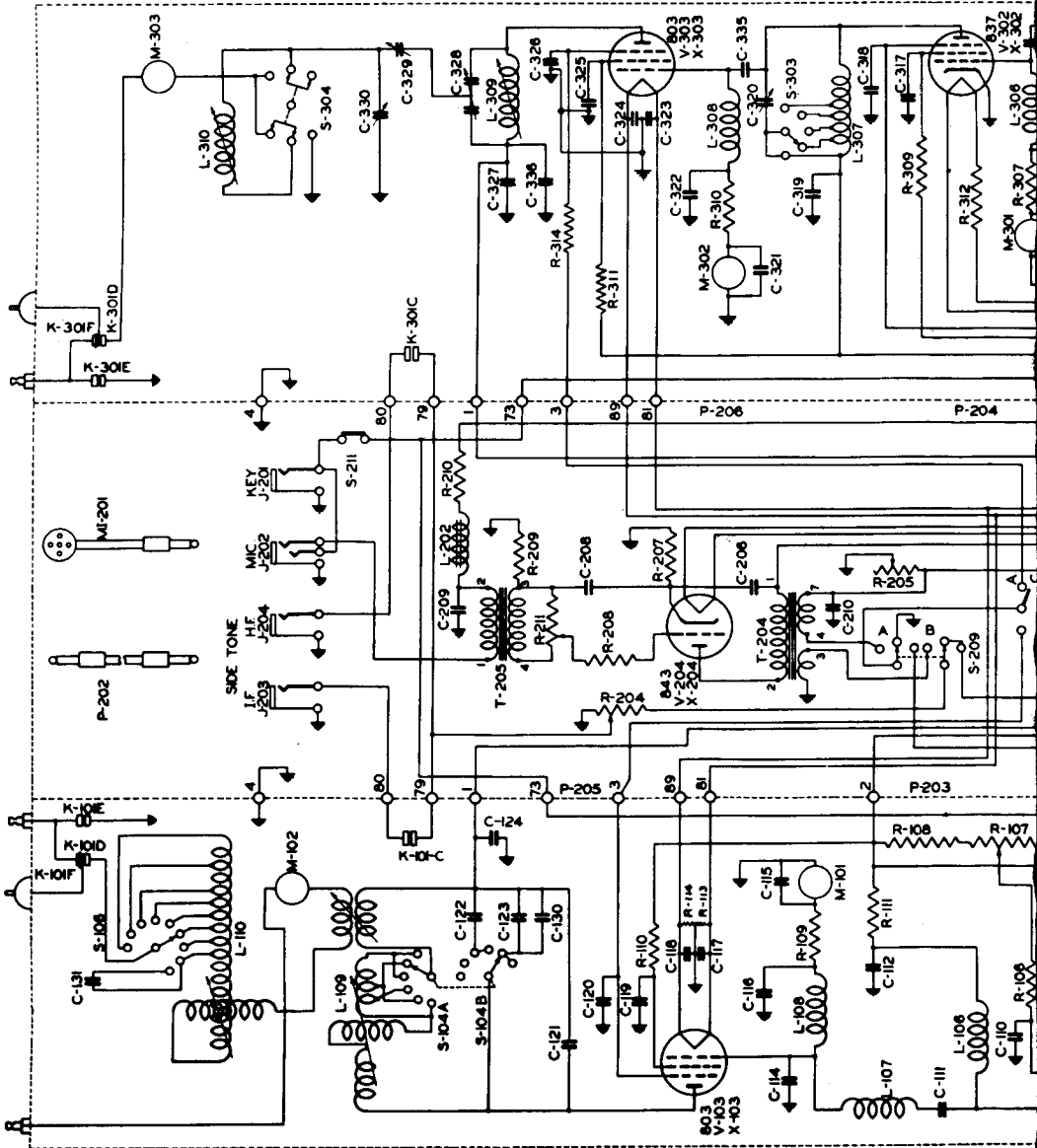

FIG. 4 - ORIGINAL SCHEMATIC OF GO-9 TRANSMITTER



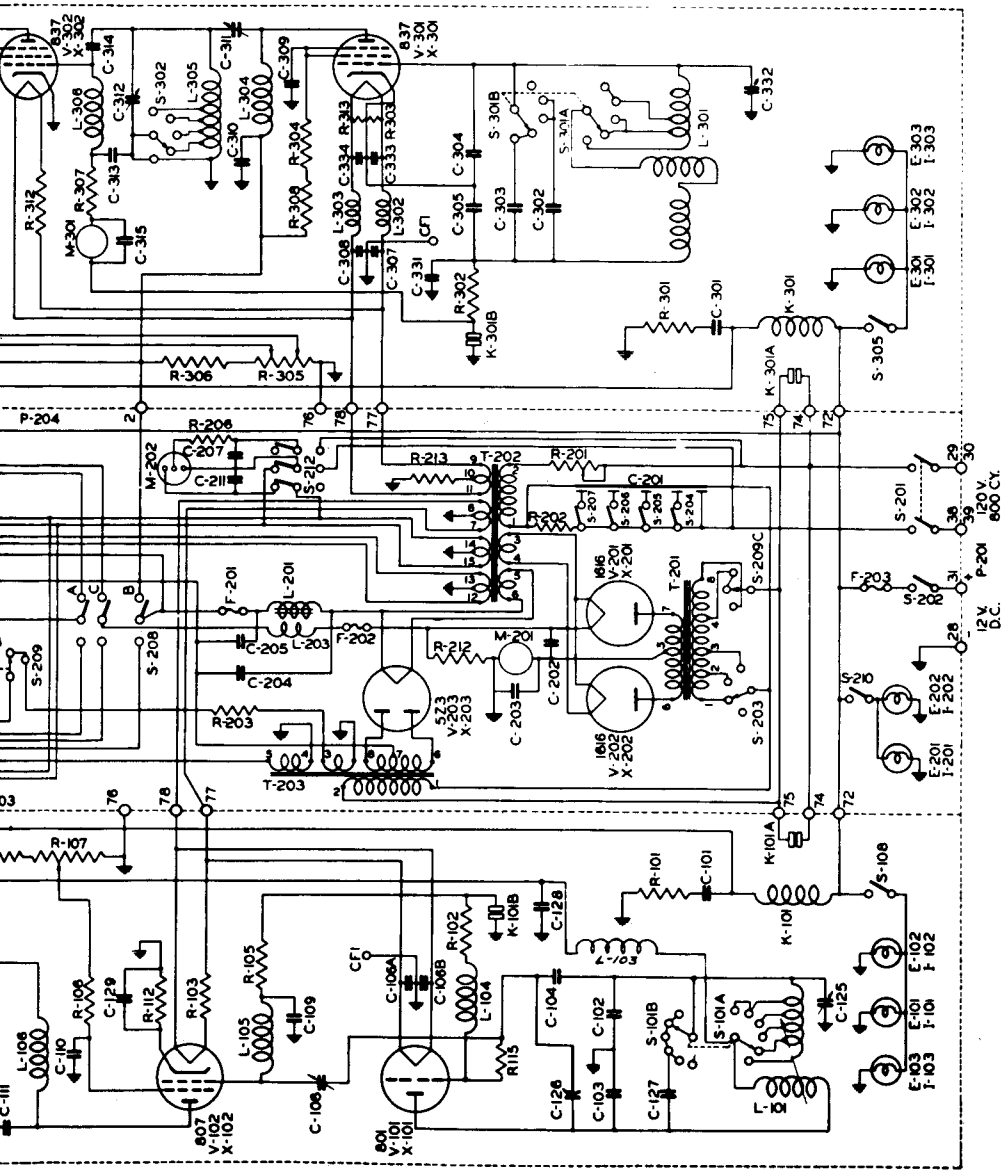

FIG. 5 - ORIGINAL SCHEMATIC OF TBW TRANSMITTER

DIAGRAM - SCHEMATIC
H.F. & I.F. TRANSMITTER & RECTIFIER

THE BC-357 MARKER-BEACON RECEIVER

Marker-beacon receivers, particularly the BC-357, have appeared in large quantity and at very moderate cost on the surplus market. The BC-357 is of little value in its original form to the average experimenter. However, its small size, and several of the components in the unit, make for easy conversion to a capacity-operated relay. This type of relay, which is caused to operate by the immediate presence of any large object, has many uses which may include the control provision for the opening of garage doors, turning on of lights or ringing of bells as an intruder protection, counting of personnel, and similar applications.

The original circuit of the receiver consisted essentially of a two-tube, tuned r-f, reflex-type receiver with its rectified output used to operate an extremely sensitive relay. The receiver is completely enclosed in an aluminum case with dimensions of 3-1/2 inches in width, 5-1/2 inches in height, and 6 inches in depth. The most valuable components of the unit are the sensitive relay and the housing. The relay will close with a current of 0.4 ma. and will open again when the current falls to 0.2 ma. The contacts are capable of carrying up to 500 ma. at low voltage without deterioration. The housing alone is excellently suited for use as a container for receivers, converters, or other items of mobile equipment.

Conversion to a Capacity-Operated Relay:

A simple Hartley oscillator is used with the sensitive relay in the plate circuit of a 6J5 tube. The circuit is self-rectifying to permit the use of the 115-volt a-c line voltage as plate supply potential. Before adding the new circuit the chassis is stripped of all components except for the relay, one tube socket, and the lower tuning condenser. The completed circuit includes a well insulated lead brought out from the grid of the oscillator. This lead should not exceed 5 or 6 feet in length and may be terminated at the existing jack on the front panel. The oscillator coil, as shown in figure 2, can be for any frequency below about 500 kc.

The operating principle is as follows: When the circuit is oscillating a relatively high bias is developed at the grid of the tube. With the high bias, which results from grid-leak action, very little plate current flows and the relay does not close. However, when the grid circuit is loaded by an external capacitance the r-f grid voltage is decreased, resulting in lowered grid bias which increases the plate current and closes the relay.

Final adjustment of the converted unit will include adjustment of the tension-spring of the relay. This spring must be adjusted to locate the operating point of the relay in the center of the tube characteristic. The unit is capable of slight r-f radiation since the external lead is coupled directly to the grid of the oscillator. However, if a frequency well below 500 kc. is used this radiation will be so small that it will not be perceptible even in a nearby receiver. A BC-348 receiver may be used to check the installation to insure that oscillator radiation is not taking place. Positive tests should be made to insure against violation of FCC regulations concerning such devices.

BC-357 MARKER BEACON RECEIVER

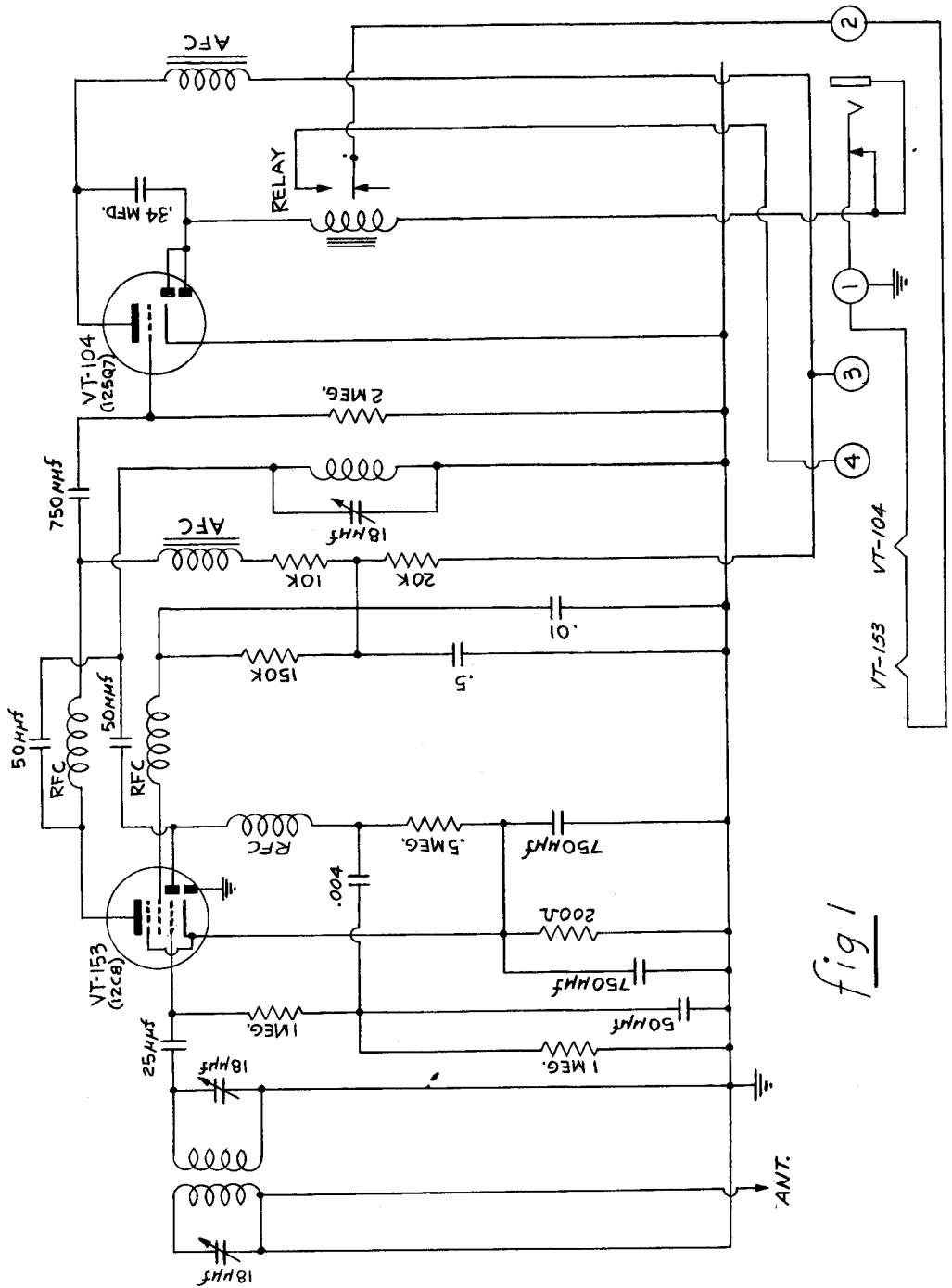
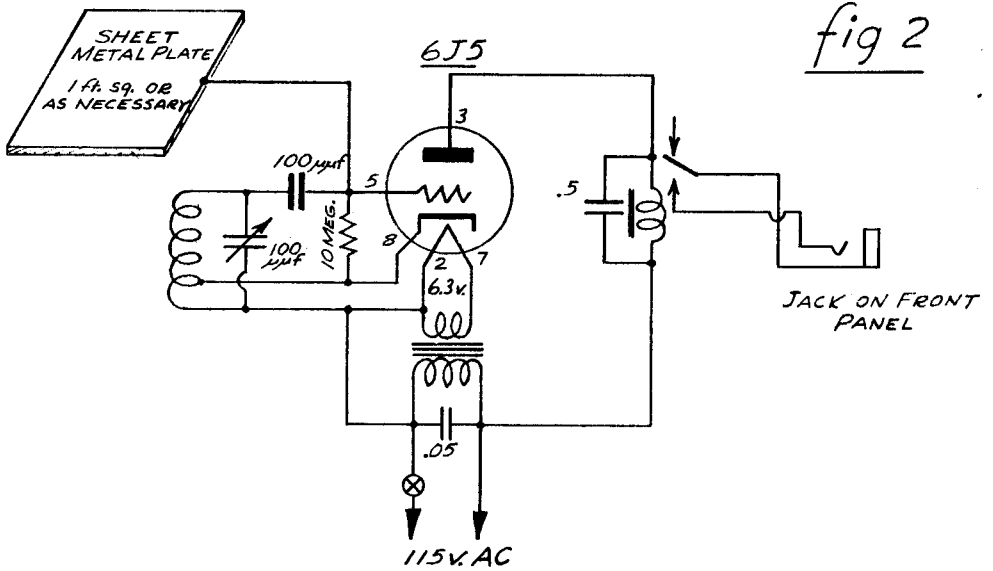
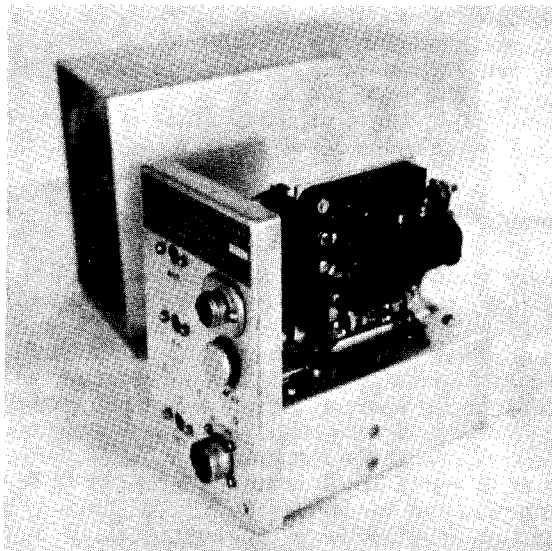

fig 1

CAPACITY OPERATED RELAY CIRCUIT



ORIGINAL BC-357 RECEIVER



HIGH-FIDELITY TUNER FROM THE BC-946B RECEIVER

The BC-946B aircraft receiver, or its Navy equivalent, in the ARC-5 series, lends itself readily for conversion to a high-fidelity broadcast tuner. This receiver is identical to the SCR-274 series except that its frequency range is 520 to 1500 kc. with an intermediate frequency of 239 kc.

Typical of aircraft equipment, this receiver was designed to operate from 28 volts, DC. The 12-volt heaters were wired in series-parallel while the high voltage was supplied by a dynamotor mounted on the rear of the chassis. The original tube line-up is as follows:

12SK7	1st RF amp
12K8	1st Detector (mixer)
12SK7	1st IF amp
12SK7	2nd IF amp
12SR7	2nd Detector, CW osc.
12A6	2nd Audio amp (output)

(a) Preparation of Chassis for Added Circuits:

After removing the bottom plate from the chassis, the three plug assemblies (J-1, front; J-3, rear; and J-2, dynamotor) with their respective wiring and hardware should be removed and discarded. This is done with the following exceptions:

- (1) The "gain control line" (green lead) from the cathode bus to pin No. 1 of J-1, should be grounded to a convenient point on the chassis.
- (2) R-22 and R-23, the tapped bleeder resistor across the plate supply which furnishes the screen voltage (approx. 100 volts) from the tap, is left intact.
- (3) C-32 is then rewired as the screen voltage by-pass from the tap on the bleeder.

All other components associated with the plugs and the audio section and the CW oscillator are completely stripped from the chassis. These include the following: L-15, L-14, C-16, L-12 and 13 (and components inside can), C-26, R-14, C-29, R-19, R-18, R-21, V-2, C-31, C-35, and T-1.

The output transformer, T-1, has a high-impedance secondary (4000 and 300 ohms) intended for headphone use and is not usable with conventional speakers.

(b) Modification of the Heater Circuit for 6-Volt Operation:

Since broadcast tuners are normally used in conjunction with a separate audio amplifier which supplies the heater and plate voltages for the tuner, 6-volt heater operation is recommended. This necessitates changes in the heater wiring as shown in Fig. 1 and the substitution of 6-volt equivalents for the existing tubes. In the tuner version, the audio output stage, (12A6), is not used and therefore no substitution is required. However, this socket affords tie points for connection of the 6E5 tuning-eye assembly. The leads are run through the center hole of the socket with the connections made underneath the chassis.

If the audio amplifier is added to the chassis as mentioned in section (i), a 6V6 output tube is substituted for the former 12A6. The heaters of the 6E5 are merely paralleled at some convenient point in the heater circuit.

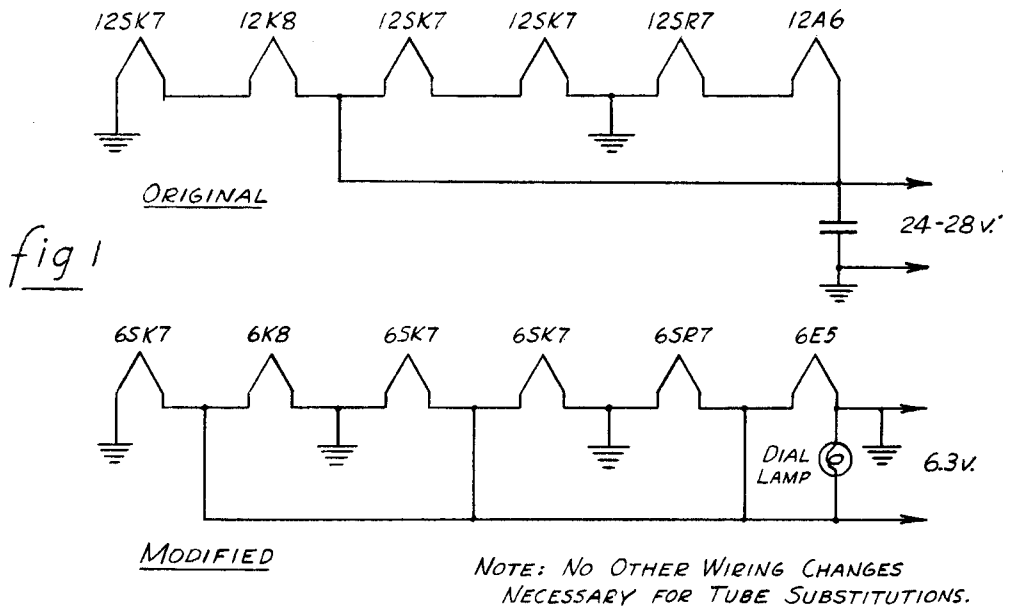

(c) AVC Circuit Modification:

In the original circuit, the AVC voltage was derived from the diode action of the second IF amplifier grid. For better performance this is changed as shown in Fig. 6 using the second diode plate of the 6SR7. This change requires removing R-11 from the grid circuit of the second IF amplifier and connecting the AVC lead to the AVC bus at the junction of C-15A.

The tuning indicator (6E5) is operated from the AVC voltage in the conventional manner as shown in Fig. 6.

(d) Audio Section:

The audio modification as shown in Fig. 7 includes the conventional volume control in the grid circuit of the 6SR7. The audio output from the triode section of the 6SR7 is brought out through the rear of the chassis with about 30 inches of shielded microphone cable. A standard microphone cable connector provides a good shielded connection to the amplifier used. The circuit components shown in Fig. 6 give audio response from approximately 30 to 10,000 cps.

(e) Power Connections:

Power connections for the tuner (6 volts and plate voltage) are brought out on the rear end of the chassis through a conventional socket. Unless a specific plug is required, the ordinary octal tube socket can be used in the former position of the J-3 plug. At this plug the "B" minus lead is grounded to the chassis as well as to one side of the heater supply voltage. It should be noted that these grounded connections must correspond to those of the power supply and amplifier used. A grounded center tap on the heater transformer at the power supply cannot be used unless the tuner heater circuit is rewired with an ungrounded system. If the heater supply is center-tapped, generally the center tap can be lifted and one side of the 6-volt circuit grounded instead.

(f) Adjustments for Operation:

After the converted tuner is operable, IF alignment and coupling adjustments should be made to obtain the broad band-pass necessary for high-fidelity reception. This phase of the conversion is the key feature for high-fidelity performance. The higher audio frequency response is primarily determined by the band-pass of the IF amplifier which in this case should approach 20 kc.

The best IF amplifier alignment can be obtained only by the scope and wobbulator method where adjustment can be made with a visual pattern of the IF amplifier response. Most of the larger radio service shops have this type of equipment.

This method of alignment results in a symmetrical waveform as produced by the three tuned stages and the proper coupling adjustments.

The proper coupling adjustment for the IF transformers will be obtained with the plungers approximately half-way in. These plungers are exposed for adjustment at the tops of the IF cans when the plastic caps are removed. Maximum coupling, which allows maximum band pass, occurs when the plungers are in; minimum coupling, or narrow band pass, is obtained by pulling the plungers out.

It should be noted here that high selectivity (sharp tuning) can be obtained, sacrificing the high frequency response, by using minimum coupling. Sharper response often becomes desirable when two stations are so close to each other that they interfere with normal or broad-band reception.

Even though maximum coupling gives a band width of approximately 25 kc. it also gives a very pronounced undesirable dip as shown in Fig. 9. This double-peak effect becomes quite obvious when tuning the receiver.

After the IF alignment and coupling adjustments are made the waveform of the IF amplifier response will be that shown in Fig. 9. Over-all frequency response of the tuner will be that shown in Fig. 10.

(g) RF Alignment Procedure:

Should it be necessary to touch up the RF alignment, which generally is not required if the dial calibration is reasonably accurate, the procedure in Fig. 2 should be followed.

(h) Mechanical Modifications and Layout:

Even though there are many possible versions adaptable to the BC-946 receiver, the following two tuning dial and panel arrangements have proven very satisfactory. These modifications are intended, where it is desired, to dress up the appearance of the tuner or its receiver version for home use.

The first version, as shown in Fig. 3a, utilizes the existing gear reduction mechanism with a centered knob assembly. The knob shaft is belt driven, with a step-up ratio to the former control shaft. This shaft carries a small flywheel in addition to the pulley which results in a pleasant smooth tuning action. The flywheel and driven pulley shaft utilize the tuning-knob assemblies that are available for the surplus SCR-274 series transmitters and receivers.

Other controls are brought out symmetrically on the panel by means of extended shafts as shown in Fig. 3a.

The second version for the tuning and panel arrangement uses the conventional type slide-rule dial (180 degrees rotation) mounted directly to the tuning condenser 1/4-inch shaft. This arrangement eliminates the former gear drive since the driven condenser gear, on the condenser shaft, is replaced with the ordinary 1/4-inch shaft coupling or extension.

To remove the condenser driven gear (split type), it is necessary to remove the condenser shield covers and the triangular plate on the right end of the variable tuning condenser. If an ordinary 1/4-inch shaft extension is used, the triangular

Intermediate frequency 239 KC
 High End 1400 KC (Adjust C4E,
 C4D, & C2)
 Low End 570 KC (Adjust C9)

fig 2

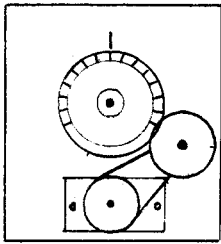
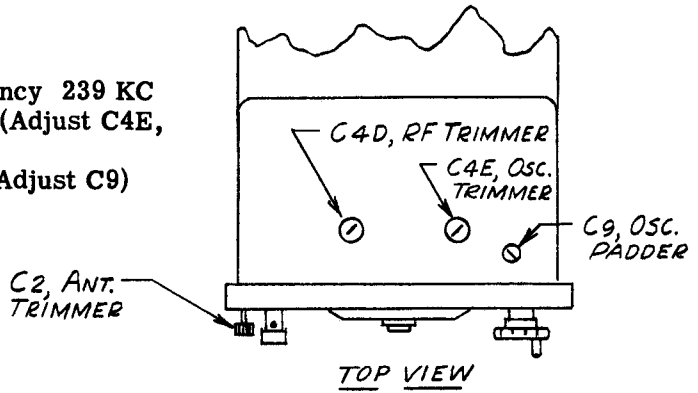

FRONT VIEW

fig 3a

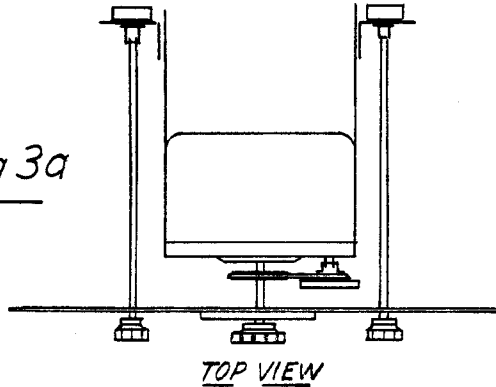

TOP VIEW

fig 3b

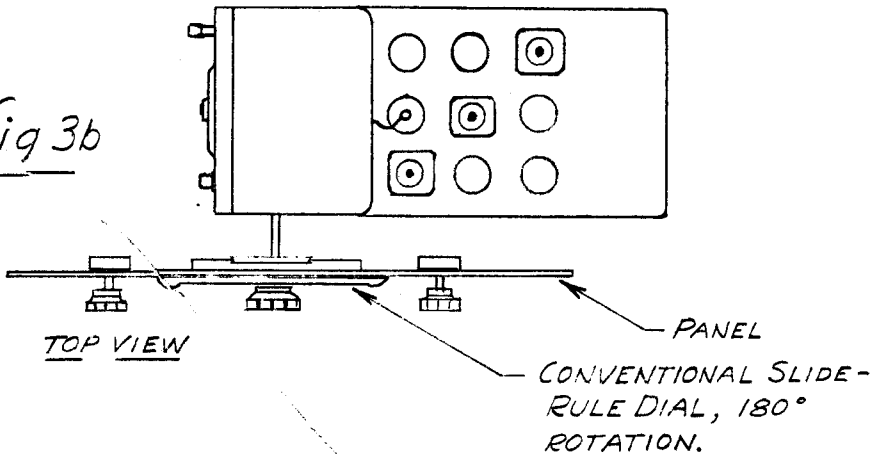

TOP VIEW

plate can be replaced and used for additional shaft support. This approach is shown in Fig. 3b.

(i) Complete High-Fidelity System from the BC-946B:

Since the chassis of the BC-946 receiver affords sufficient space for additional components, the additional components to make up a complete radio receiver can be successfully added.

The first version utilizes a power supply mounted in the former dynamotor space, as shown in the photographs. The output stage consists of a 6V6 which occupies the former 12A6 socket. Due to the lack of space and to avoid inductive hum pick-up from the power transformer, the output transformer is mounted on the speaker frame or cabinet.

This version, in Fig. 7, using the single-ended 6V6 is capable of delivering 4 watts at less than 6% distortion. At normal listening level (approximately 1 watt) the percentage distortion is negligible for all practical purposes. With application of inverse feedback, distortion can be reduced.

The second version for the high-fidelity radio and amplifier incorporates the audio amplifier on the BC-946B chassis but uses the power supply as a separate unit. The amplifier section utilizes push-pull 6V6's operating AB₁ and is capable of delivering 10 watts at less than 3.5% distortion when used with the recommended power supply.

It will be noted from the schematic diagram, Fig. 8, that the amplifier section uses the floating-paraphase form of inversion and a small amount of inverse feedback. This design accounts for better performance from the 6V6's. Dual tone controls (bass and treble) are used to give high or low end boost or attenuation. A phono input also is incorporated.

(j) Speaker Cabinet:

The reflex-type speaker cabinet as shown in Fig. 4, for use with a 12-inch speaker, provides exceptional performance. This type of cabinet acts as a resonant cavity toward the lower frequencies and improves the over-all listening response.

NOTE: INSIDE BACK SURFACE IS COVERED WITH HAIR FELT OR GLASS WOOL.

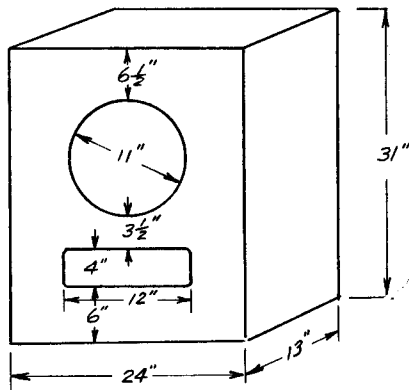
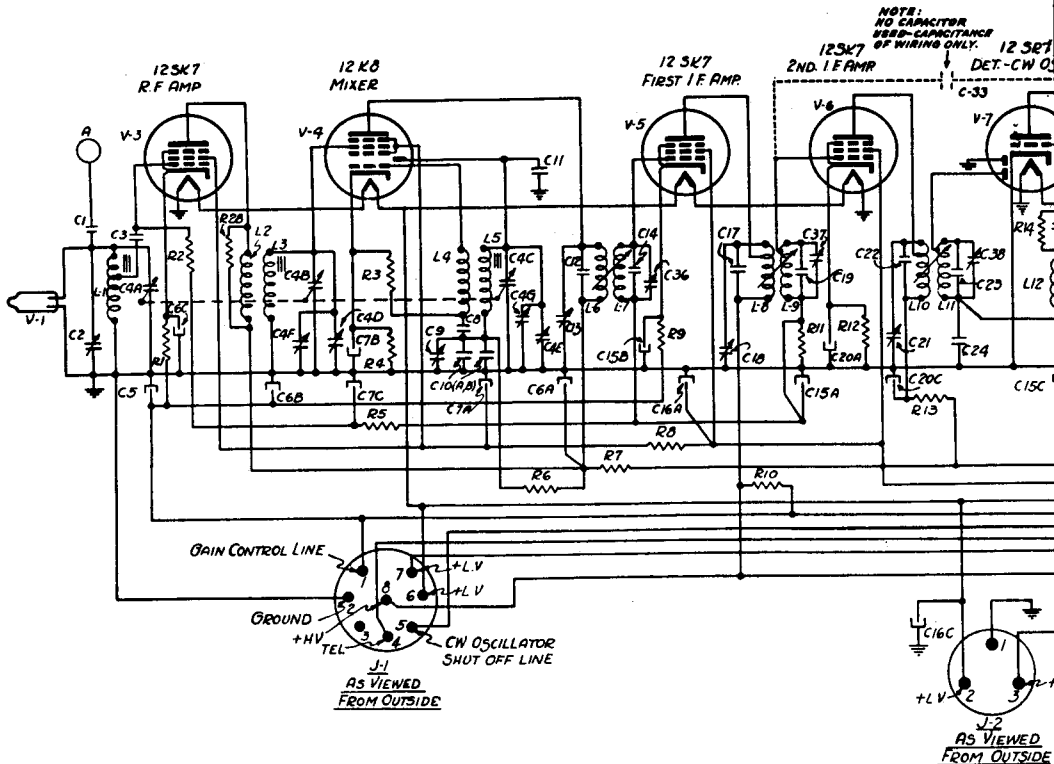
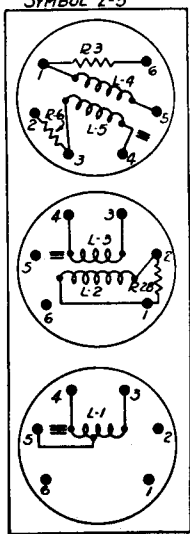

fig 4



CIRCUITS IN RF COIL SET, IF COUPLING UNITS, CW OSCILLATOR, & OUTPUT TRANSFORMER THE TERMINAL NUMBERS ON THESE UNITS AGREE WITH THOSE SHOWN AT THE CORRESPONDING LOCATIONS ON THE WIRING DIAGRAM

RF COIL SET
SYMBOL Z-5



IF COUPLING UNITS

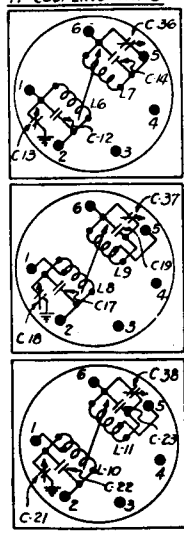

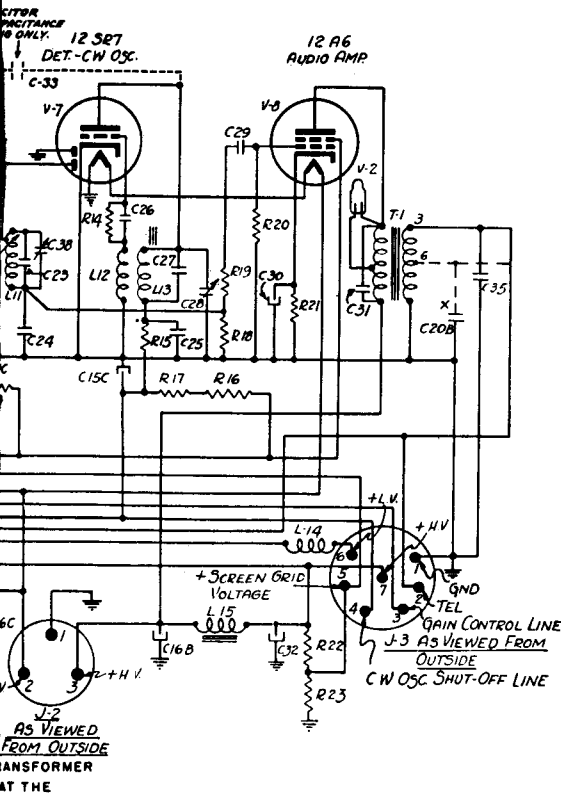

CAPACITANCES		INDUCTANCES		RESISTANCES	
SYMBOL	DESCRIPTION	SYMBOL	DESCRIPTION	SYMBOL	OHMS
C-1	11 MMF	L-1	ANT. INPUT	R-1	620
C-2	18 MMF	L-2, L-3	RF AMP	R-2	2,000,000
C-3	100MMF	L-4, L-5	RF OSC	R-3	51,000
C-4 (A TO C)	GANG (346 MMF)	L-6, L-7	IN FIRST IF	R-4	620
C-5	3 MFD	L-8, L-9	IN 2ND IF	R-5	150,000
C-6 (A,B,C)	05/05/05 MFD.	L-10, L-11	IN 3RD IF	R-6	300,000
C-7 (A,B,C)	05/05/05 MFD	L-12, L-13	CW OSC	R-7	200
C-8	200 MMF	L-14	RF CHOKE	R-8	200
C-9	40 MMF		112 MICRO- HENRIES	R-9	620
C-10 (A B)	670MMF TOTAL		3 HENRIES	R-10	360,000
C-11	3 MMF	L-15	AF CHOKE	R-11	100,000
C-12	180 MMF			R-12	510
C-13	17 MMF			R-13	200
C-14	180 MMF			R-14	100,000
C-15 (A,B,C)	05/05/05 MFD			R-15	20,000
C-16 (A,B,C)	22/22/22 MFD			R-16	100,000
C-17	180 MMF			R-17	100,000
C-18	17 MMF			R-18	510,000
C-19	180 MMF			R-19	100,000
C-20 (A,B,C)	05/01/05 MFD			R-20	2,000,000
C-21	17 MMF			R-21	1600
C-22	180 MMF			R-22	7000
C-23	180 MMF			R-23	7000
C-24	200 MMF			R-28	51,000
C-25	.001 MFD				
C-26	100 MMF				
C-27	335 MMF				
C-28	34 MMF				
C-29	.006 MFD				
C-30	15 MFD				
C-31	.001 MFD				
C-32	5 MFD				
C-33	WIRING CAPACITANCE LESS THAN 2 MMF				
C-35	750 MMFD (SEE NOTE BELOW)				
C-36	17 MMF				
C-37	17 MMF				
C-38	17 MMF				

AS VIEWED FROM OUTSIDE TRANSFORMER AT THE

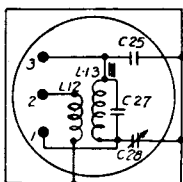

SYMBOL Z-4 CW OSCILLATOR (239 KC)

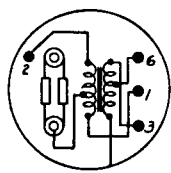

SYMBOL T-1 OUTPUT TRANSFORMER

fig 5

TUBE SOCKET TERMINALS AS VIEWED FROM BOTTOM

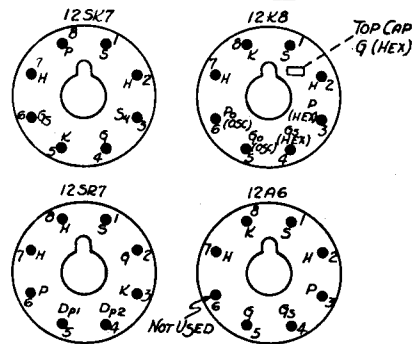

TUBE TERMINAL CODE

- S = SHELL
- H = HEATER
- K = CATHODE
- S_w = SUPPRESSOR GRID
- Dp₁ = FIRST DIODE PLATE
- Dp₂ = SECOND DIODE PLATE
- Q = CONTROL GRID
- G_s = SCREEN GRID
- G_s(HEX) = SCREEN GRID, HEXODE SECTION
- G_o(OSC) = CONTROL GRID, OSC. SECTION
- P = PLATE
- P(HEX) = PLATE, HEXODE SECTION
- P_o(OSC) = PLATE, OSC. SECTION
- Q(HEX) = CONTROL GRID, (HEXODE SECTION)

① C-35 & TERMINAL 3 TO BE USED FOR 4000 OHM OUTPUT
C-20B & TERMINAL 6 TO BE USED FOR 300 OHM OUTPUT

Radio Receiver BC-946-B — Schematic Wiring Diagram

AUDIO SECTION FOR HIGH-FIDELITY TUNER

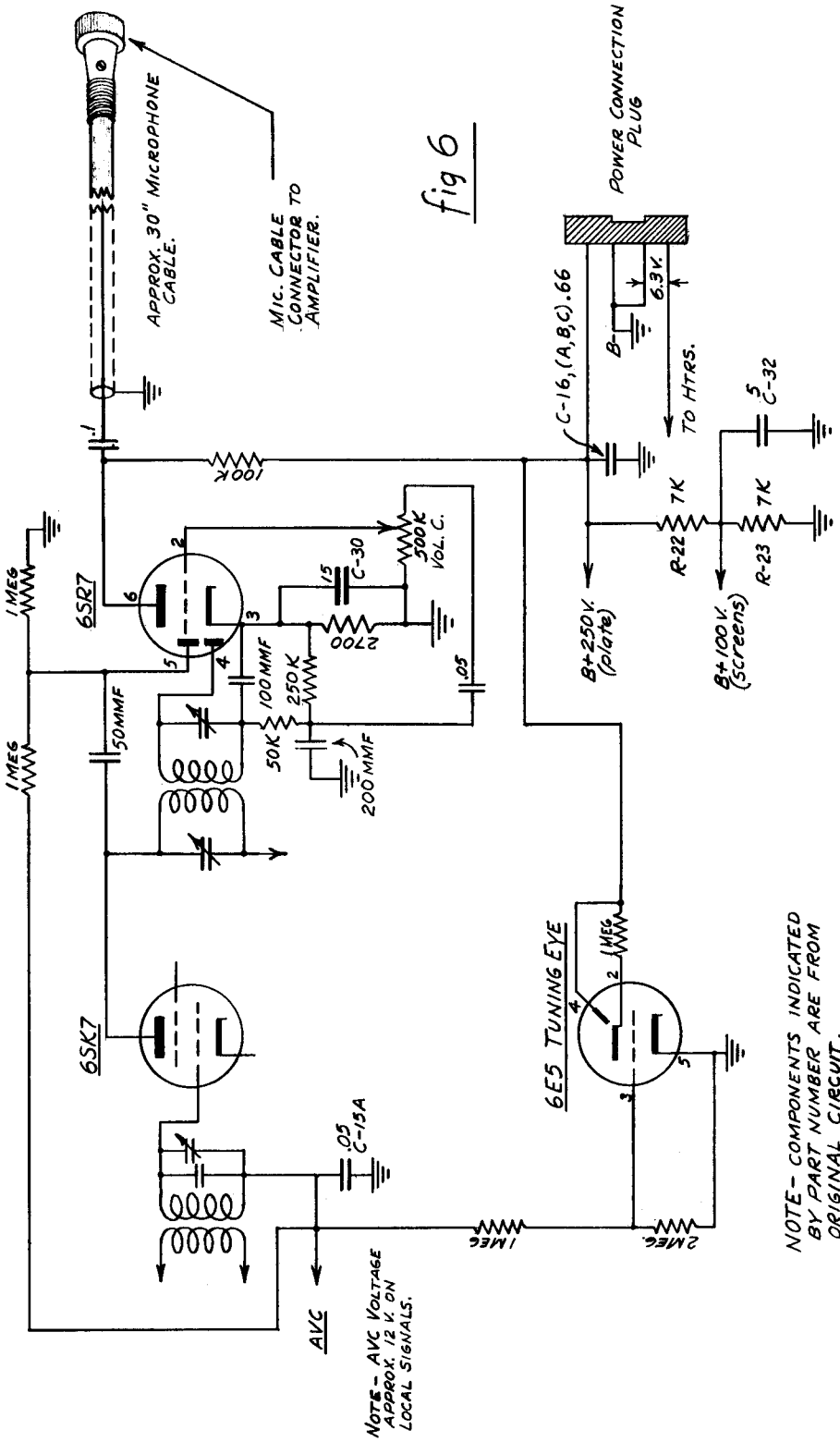

fig 6

NOTE - AVC VOLTAGE APPROX. 12 V ON LOCAL SIGNALS.

NOTE - COMPONENTS INDICATED BY PART NUMBER ARE FROM ORIGINAL CIRCUIT.

AF AMPLIFIER FOR HI-FI TUNER

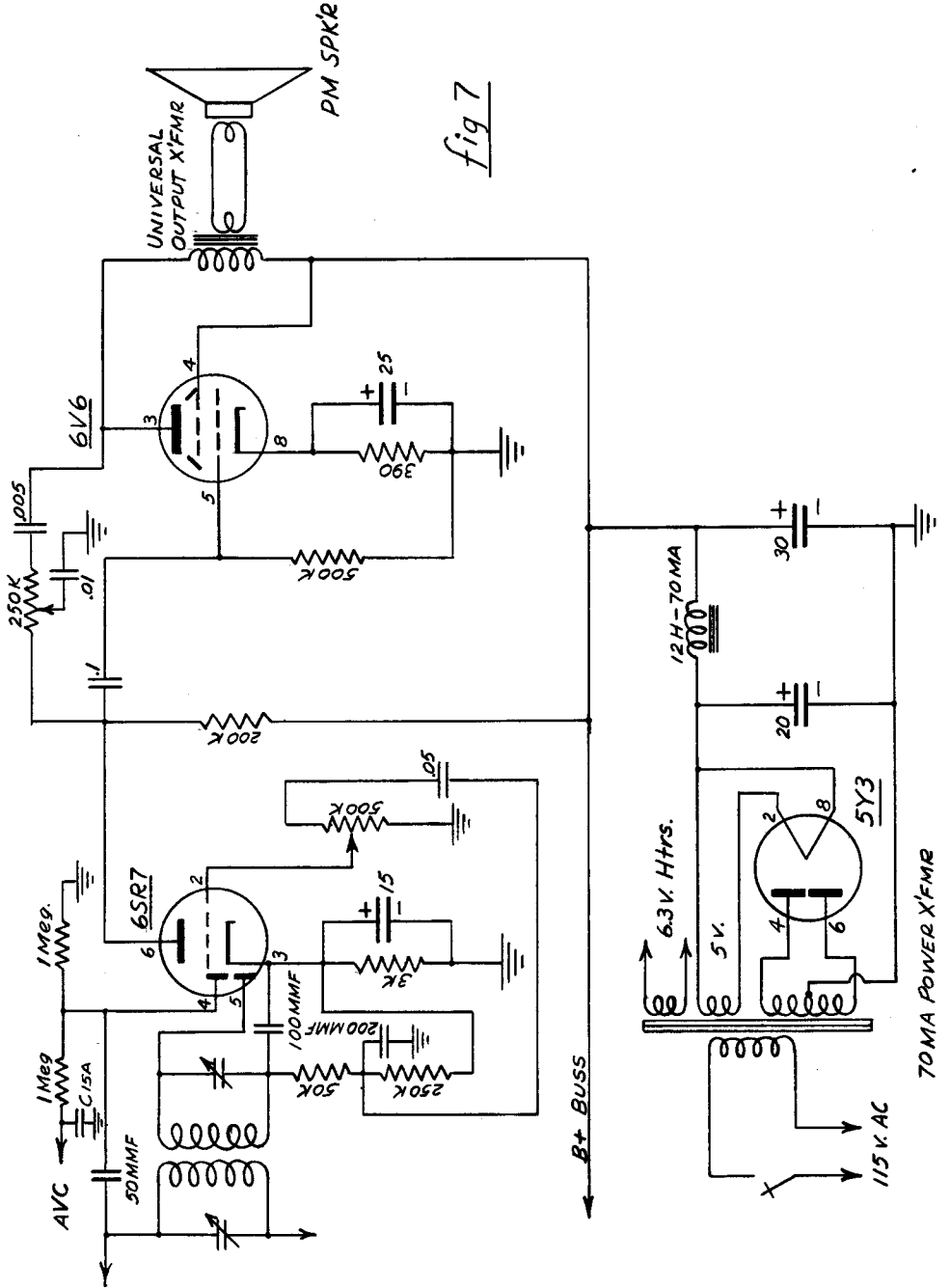

fig 7

10-WATT AUDIO SECTION

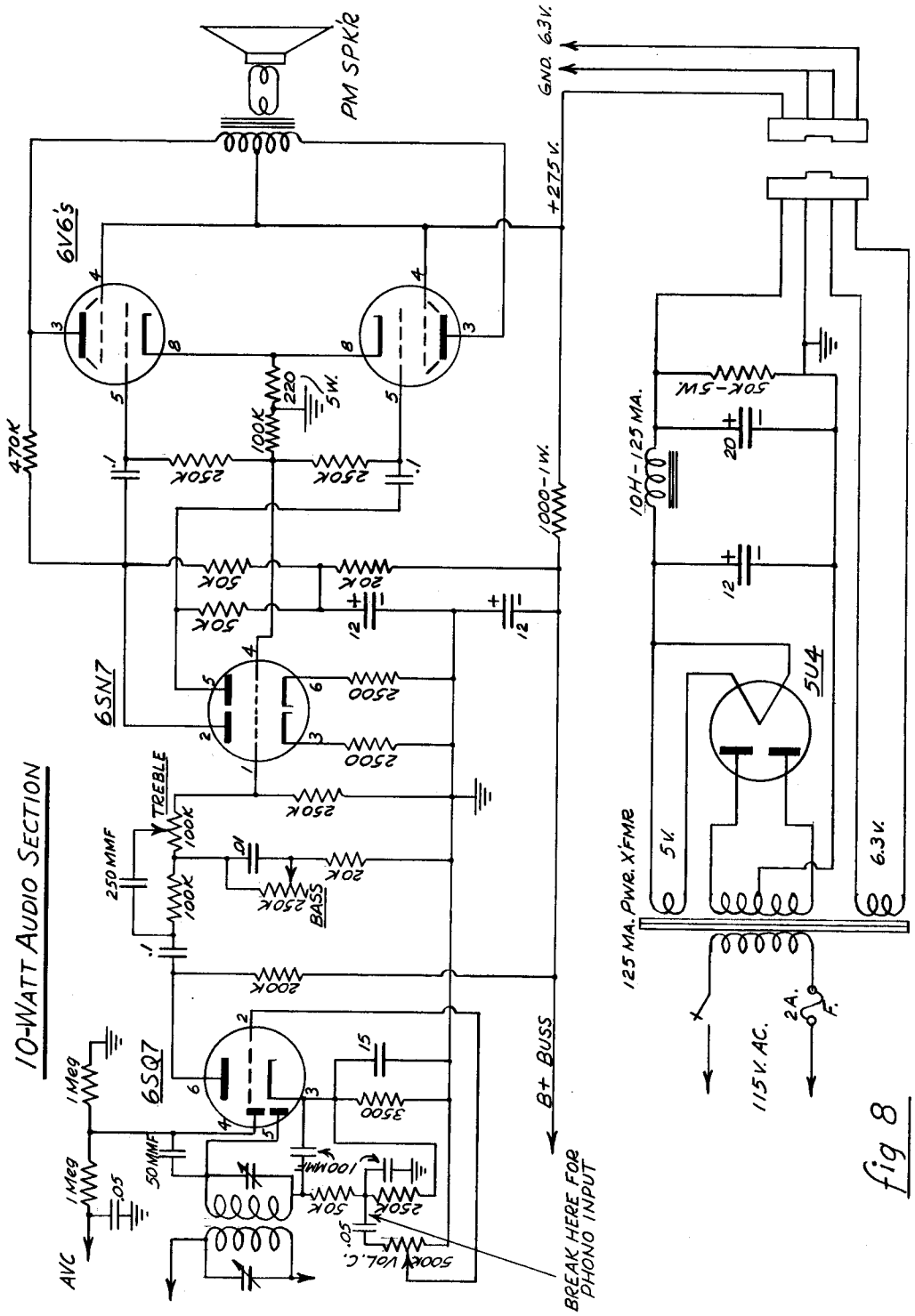
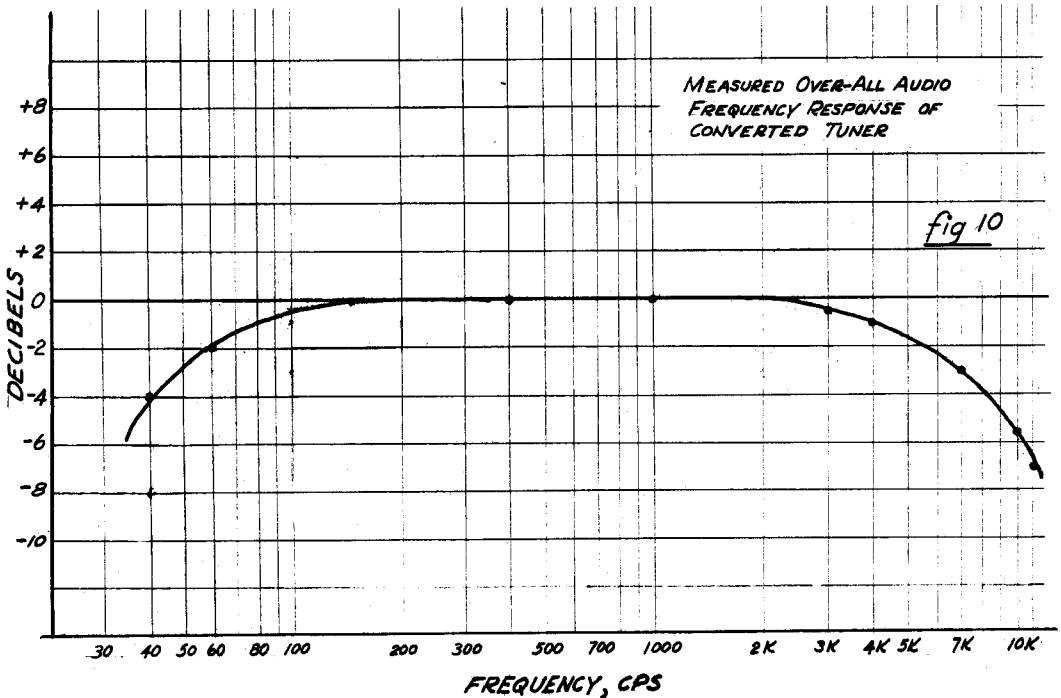
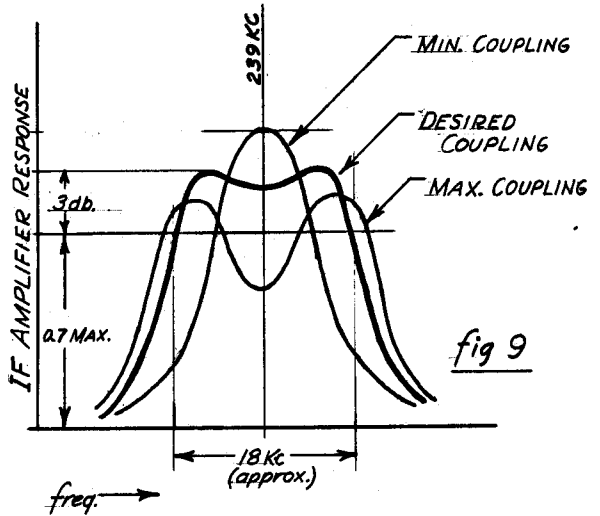
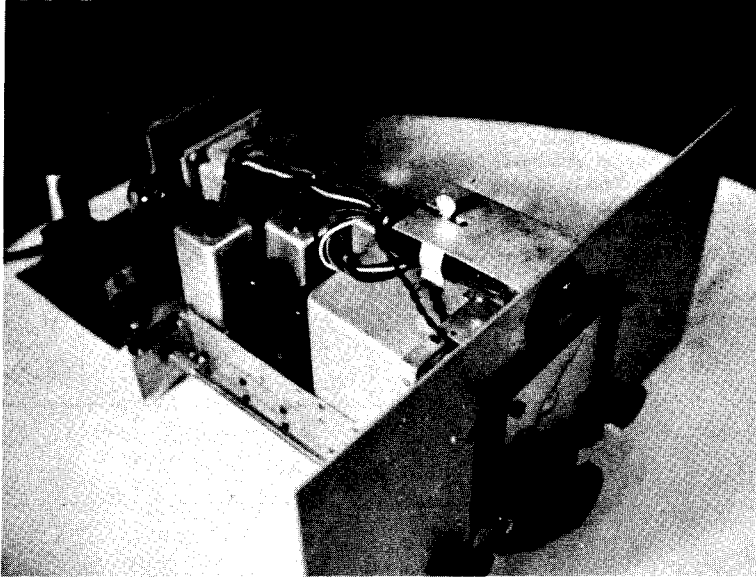

fig 8

By the wobulator-scope method of IF alignment and coupling adjustment, similar scope patterns can be obtained as shown here. This response is indicative of the audio response of the tuner assuming a flat response of the audio system for the frequency range in question.

The low frequency droop in the over-all response (modulated RF signal) as shown in fig. 4, is due to the audio characteristic of the system used.





CONVERTED BC-946B WITH SINGLE
ENDED AUDIO SECTION

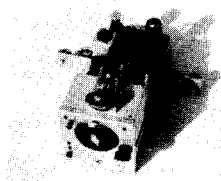

CONVERTED BC-946B WITH PUSH-PULL
AUDIO SECTION

fig 11

BC-375 TRANSMITTER

One of the most widely known and widely available units of surplus transmitting equipment is the BC-375. Due to the relatively poor frequency stability of the transmitter, few amateurs have had the temerity to attempt to operate the transmitter as it originally was designed. By far the majority have disassembled both the transmitter proper and the tuning units for the wealth of usable components which they contain.

However, this section describes a relatively simple and quite practical conversion procedure by which the transmitter may be operated substantially intact and still meet the FCC requirements for transmitted frequency stability of signals on the amateur bands. The conversion procedure consists essentially of two steps: (1) The construction of two power supplies, 24 volts d.c. at 7.5 amperes and 1000 volts at 300 ma., either of which is universal in its application so that it may be used with any item of equipment in addition to serving as a portion of the BC-375 transmitter system. And (2), the modification of the tuning units so that an external v.f.o. may be used to excite the original oscillator of the MOPA transmitter so that this stage operates as a buffer amplifier or as a frequency doubler.

(a) Description of the BC-375 Transmitter:

The BC-375 transmitter originally was designed for and used in larger military aircraft. It is capable of delivering 45 to 100 watts output over a wide frequency range into an antenna system such as could be installed on an aircraft. The r-f circuit uses a 211 (VT-4C) as master oscillator and another 211 as power amplifier. The audio system uses a 210 speech amplifier or tone generator and a pair of 211 tubes in push-pull as modulators.

The transmitter is provided with a quite flexible antenna-loading circuit. The output may be coupled into a single straight wire of any reasonable length.

Power requirements for the BC-375 are 24/28 volts DC at approximately 600 watts for CW operation and about 850 watts for phone. Plate voltage is obtained from the PE-73 28-volt dynamotor which requires approximately 20 amperes under normal operating conditions. Its high voltage output is 1000 volts at 500 ma. Physically identical with the BC-191, the dimensions of the BC-375 are 20" high x 22" wide x 8" deep.

The complete equipment, with the BC-375 as the primary component, is as follows:

Transmitter	BC-375
Tuning Units	TU-5B (1500-3000 kc.), TU-6B (3-4.5 Mc.), TU-7B (4.5-6.2 Mc.), TU-8B (6.2-7.7 Mc.), TU-10B (10-12.5 Mc.)
Antenna Tuning Unit	BC-306
Dynamotor	PE-73
Carbon Microphone	T-17, etc.

The significant difference between the BC-191 and the BC-375 is that the former operates from 12-volt source for its filament and relay circuits. In the DC version (component of the SCR-177), the transmitter plate power was derived from a 12-volt dynamotor, while in the AC version (component of the SCR-188) all transmitter power requirements were derived from AC power unit RA-34. This power unit, designed to operate from 105-125 volts or 210-250 volts, 50/60 cycles, furnishes filament, mike, and plate voltages for the 12-volt transmitter. The dimensions of the RA-34 are 13-7/8" x 12-11/16" with its weight being 140 pounds.

(b) Power Supply Equipment:

If one is not a proud possessor of an RA-34 power unit, two power supplies for the filament and plate requirements of the BC-375 must be constructed. The filament power supply must provide 24 volts DC at approximately 8 amperes. The construction of this unit involves more expense than if only AC transformers are used, but is justified for several reasons. First, it is very difficult to get at the filament circuits to make any changes. Second, direct current must be used to permit the use of the antenna relay. Third, a certain amount of AC hum from the filament tubes must be tolerated unless special balancing circuits are used with AC filament power.

A power supply to meet the requirements is shown in Fig. 2. The selenium rectifier, with a single section filter, provides sufficiently smooth DC for operation of the filament and relay circuits.

The high-voltage plate supply must deliver approximately 1000 volts at about 300 ma. The circuit shown in Fig. 3 for the high voltage supply has proven to be satisfactory. As previously mentioned, this supply is of conventional design so that it may be used with other equipment. Power connections to the transmitter are made at the plug connections as also shown in Fig. 3.

(d) Modification for VFO Excitation:

The two power supplies described above will operate the transmitter as it was originally used in the military service. However, the instability of the master oscillator is considerably outside the limits for amateur operation as specified by the FCC. This situation may be corrected by modifying the original master oscillator to function as a neutralized buffer amplifier stage driven by an external VFO. Any VFO with sufficient power output and the proper frequency range will be satisfactory. However, the surplus SCR-274N transmitter, when converted, serves the purpose very well.* The output frequency of the VFO must be 3.5 Mc. for 3.5 and 7 Mc., and 7 Mc. for 7 and 14 Mc. transmitter operation. The BC-459 (7 to 9.1 Mc.) when used as the VFO permits both 40 and 20 meter operation. For 20 meter operation, the original master oscillator stage functions as a doubler. Although this stage is quite inefficient when operating as a doubler, satisfactory operation can be obtained by supplying adequate drive from the VFO.

If the BC-696 transmitter (converted) is used for the VFO, 80 and 40 meter operation of the transmitter can be obtained. It should be noted that frequency multiplication greater than two in the converted master oscillator stage is unsatisfactory due to low efficiency.

To modify the original master oscillator for operation as a neutralized buffer amplifier stage or as a doubler, it is necessary to construct a tuned grid circuit for the VT-4C (211) stage. This circuit consists of a tank which may be tuned either to the 80 or 40 meter bands. It is link coupled as shown in Fig. 4 to a coaxial connector mounted on the side of the transmitter.

The tuned circuit is mounted on the main frame of the transmitter and should be located as near to the tube as is possible. It should be placed just behind the front panel with its tuning and switch controls brought out through the panel. The circuit and the components required are shown in Fig. 4.

(e) Conversion of the Tuning Units:

Modification of the tuning units primarily involves changing the original oscillator circuit to a neutralized amplifier or doubler circuit. Additional modification of the excitation and neutralization taps for the PA also are suggested for increasing excitation to the PA. The tuning units described provide 80, 40 and 20 meter operation with sufficient excitation to the final to realize an RF output of approximately 100 watts.

* "Surplus Radio Conversion Manual", Volume I

Tuning Unit TU-6B (3-4.5 Mc.):

This tuning unit requires only minor changes to permit straight-through operation from the 80-meter VFO. An added 50 uufd. variable transmitting-type condenser is used at the cold end of the buffer tank for neutralizing as shown in the converted TU-6B schematic diagram, Fig. 5. The condenser is mounted in the buffer compartment (originally oscillator compartment) with its screwdriver adjustment accessible through the rear panel of the tuning-unit chassis. Stand-off's should be used for mounting the condenser.

For increased excitation to the PA, the excitation tap is moved to the "hot" end of the coil while the neutralizing tap relocated at the bottom or "cold" end. Switching of positions for these two taps should be obvious from the "before and after" diagrams, Fig. 5.

Tuning Unit TU-8B (6200-7700 kc., 40 Meters):

This unit may use the buffer stage as a straight through amplifier or as a doubler, depending on the VFO source. Output is for 40-meter operation.

The same operations for modification are required as in the case of the TU-6B if excitation is to be supplied on 7 Mc. Considerably less capacitance is required for the added neutralizing condenser, thus permitting the use of a 25 uufd. variable. Similarly, the control shaft is extended through the rear of the unit for screwdriver adjustment. The neutralizing condenser is added to the TU-8B in the same circuit position as shown for TU-6B in Fig. 5 if excitation will be supplied on 7 Mc. to the unit. Fig. 6 shows the proper circuit connections for the TU-8B when the first 211 tube is to be operated as a doubler from 3.5 Mc. with 7 Mc. output. Note that it is not necessary to install a neutralizing condenser when this stage is to be operated as a doubler. It is necessary, however, to remove the oscillator feedback condenser from inside the tuning unit, as shown in Fig. 6. The excitation and neutralizing leads to the PA should be interchanged as described for the TU-6B to provide greater drive for the PA.

If the neutralized buffer amplifier stage is to function as a doubler, neutralization for this stage is not necessary. However, to improve its doubling efficiency, the grid bias for the stage is increased. This is accomplished by inserting a 75K ohm resistor in the grid bias lead as shown in Fig. 6. Even though this operation materially improves the doubling efficiency, considerably more drive from the VFO is required for doubling than for straight-through operation.

Tuning Unit TU-10B (10-12.5 Mc., 20 Meters):

For 14-Mc. operation, with excitation from the VFO on 7 Mc., the buffer amplifier must function as a doubler. As mentioned previously, this stage is not efficient as a doubler. To compensate for the inefficiency, added drive from the VFO is required as well as increased bias for the stage. The additional bias is obtained by insertion of the 100K resistor in the grid-bias lead as shown in the schematic diagram, Fig. 7.

As mentioned above, neutralization is not required for the buffer stage when it functions as a doubler, thus eliminating the need for the neutralizing condenser required for straight-through operation. The PA excitation and neutralization taps are interchanged for increased excitation as with the other tuning units.

One more operation is required to bring the tuning unit into the 14-Mc. range. This involves shorting out one turn at the cold end of both the buffer amplifier and PA tank coils. The shorting can be accomplished by flowing solder across the two end turns in both cases. One point that should be mentioned is that the taps on the buffer coil must remain an equidistant number of turns from the center-tap connection.

(f) Modifications for the Modulator:

The existing modulator is incapable of full modulation of 100 watts output from the PA. This is due to insufficient drive from the carbon mike and the 210 audio amplifier.

Since a pair of push-pull 211's are capable of much more audio than really necessary, increased drive will solve the problem. This may be accomplished by inserting an additional audio stage between the mike and the 210 stage. For convenience, the added tube may be coupled to the 210 through the existing mike transformer, with a plate to 200-ohm transformer used to match the plate of the added tube to the existing mike input.

A more refined solution to the audio amplification problem would be to construct a new preamplifier and driver to replace the 210 stage. The driver transformer to the modulator grids has several taps ranging from 150 to 4000 ohms, thus allowing flexibility in the choice of the output stage of the audio amplifier driver.

Higher bias is required for increased output from the class B 211 modulator. Fixed bias is preferred and can be obtained from a 75 volt B battery. It should be noted that the modulation can be increased materially without the addition of fixed bias. However, it is suggested that fixed bias be added since modulator bias was obtained from the PA grid leak resistor in the original circuit. Hence the modulator bias fluctuates with the PA grid current.

(g) Operation:

Operation of the BC-375 transmitter on amateur frequencies does not require the BC-306 antenna tuning unit. Various feeding circuits may be selected by the antenna circuit controls. The BC-375 output circuit is not readily adaptable to feeding a balanced load, although satisfactory results often may be obtained.

Antenna loading can be roughly determined by the RF ammeter located in the upper part of the antenna tuning section. During initial tests and tuning, reduced voltage should be used so as to avoid damage to the tubes. The original calibration charts will not be correct for the new tuning unit circuits. Therefore the dials should be recalibrated with a reliable frequency meter.

TYPICAL TRANSMITTER TUNING UNIT TU-9-B

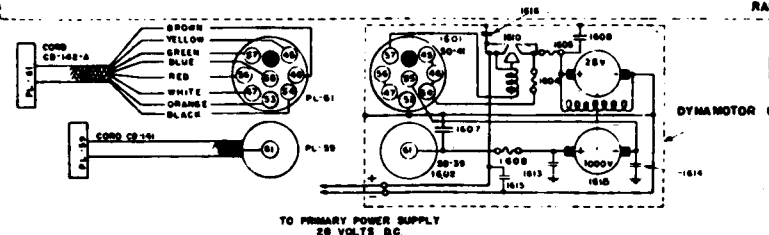
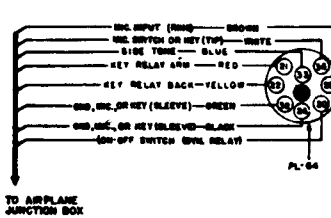
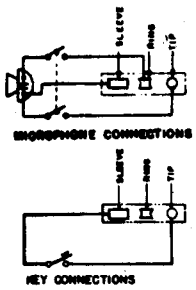
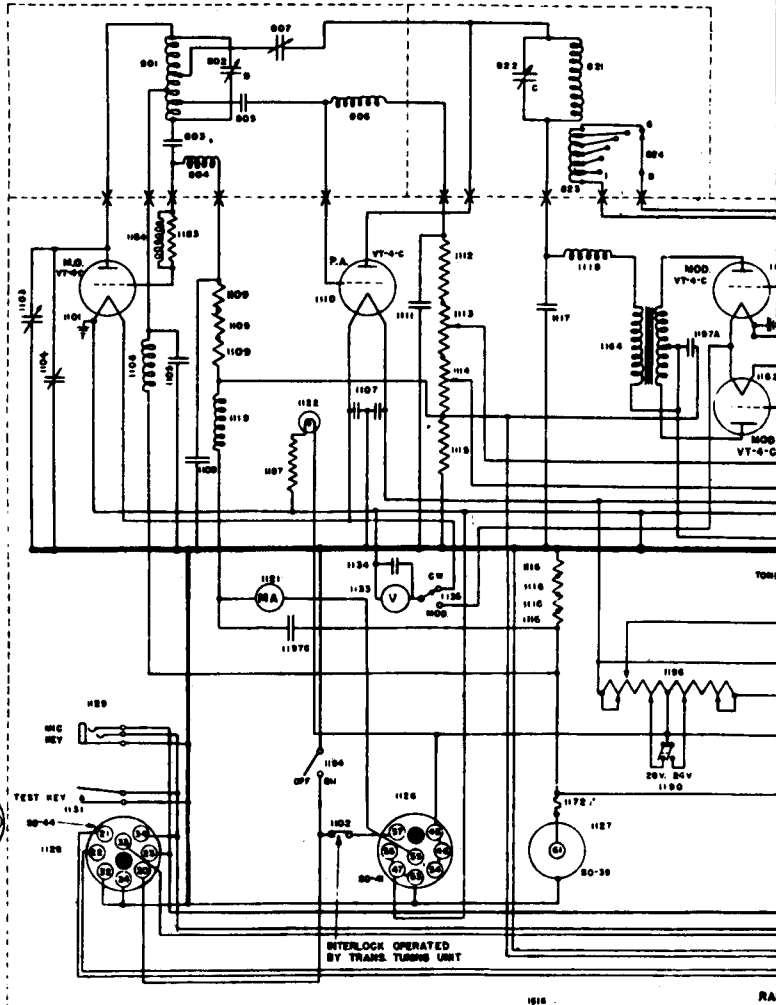

FILAMENT POWER SUPPLY

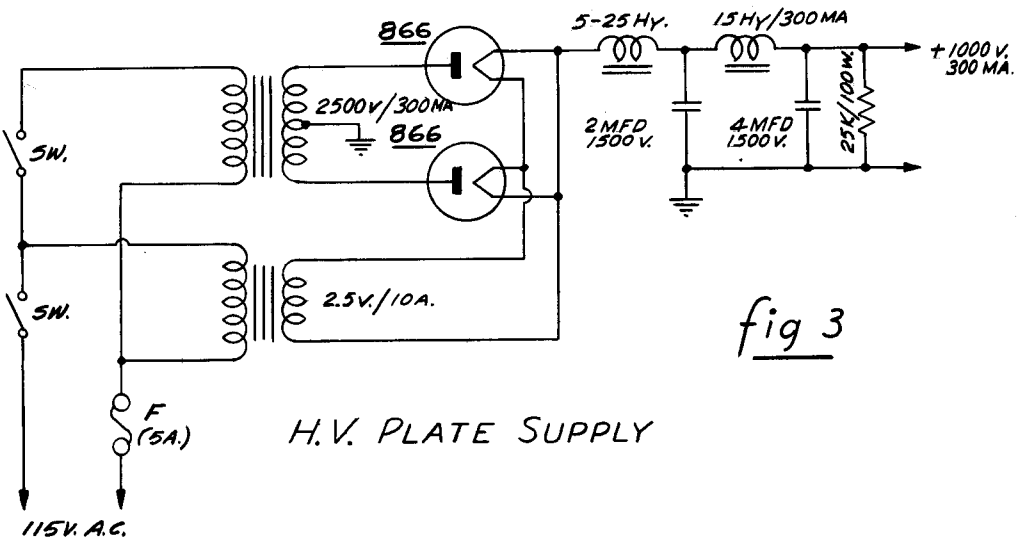
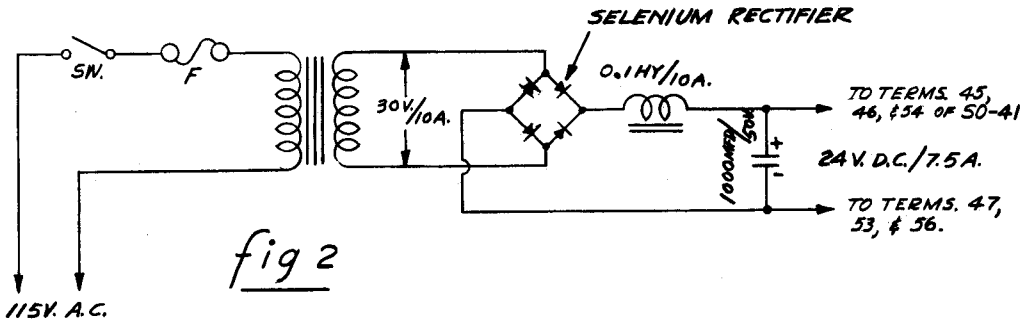

MODIFIED NEUTRALIZED BUFFER AMPLIFIER

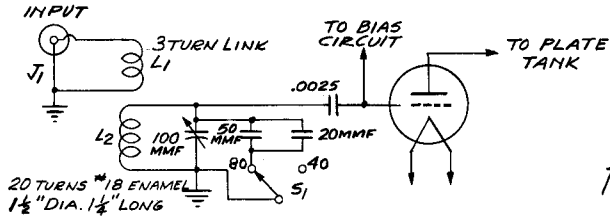

fig 4

NOTE: ALL FIXED CONDENSERS ARE MICA.

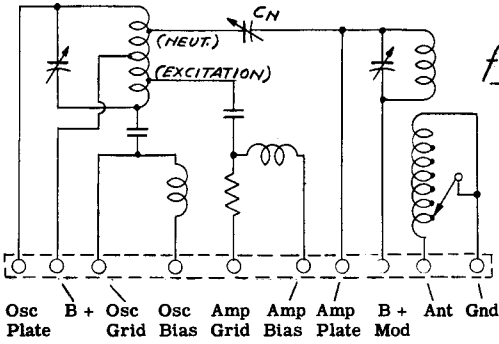

fig 5

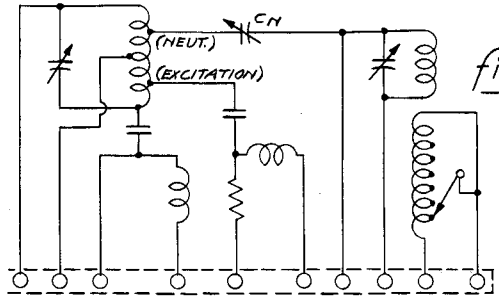
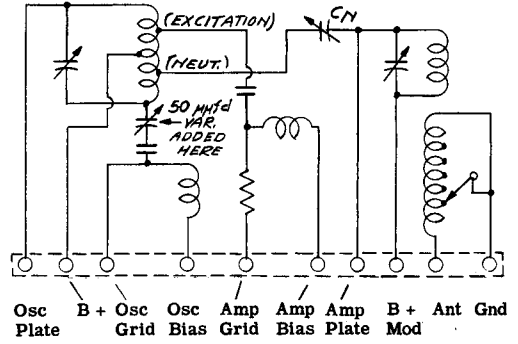

fig 6

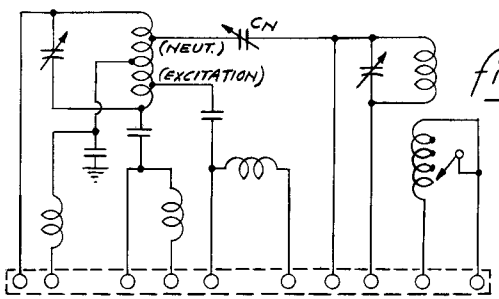
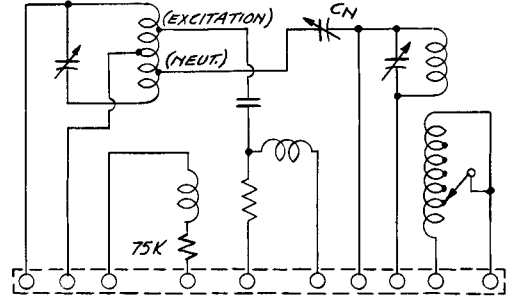
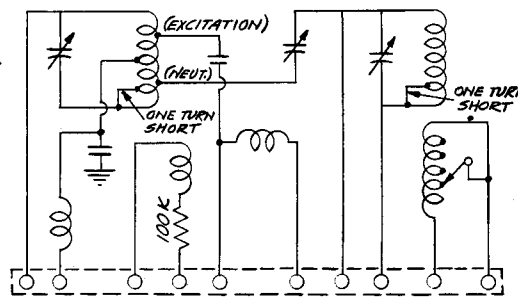

fig 7



(BEFORE)

(AFTER)

CONVERSION DATA FOR THE MODEL TA-12B AND TA-12C BENDIX TRANSMITTERS

The Bendix TA-12B transmitter comprises a remotely controlled, four-channel, 40-watt output, master oscillator type transmitter. The four-channels provide telephone, CW, or MCW operation in the frequency ranges of 300-600 kc. and 3000 to 7000 kc. The TA-12C covers the range 300-600 kc. and 3000-12,000 kc.; otherwise the two are identical.

The transmitter is one of the most attractive to appear on the surplus market and is ideal for the amateur in need of a desk-sized transmitter to cover several of the amateur bands.

The unit is quite light, weighing only about 35 lbs, and in physical size is 15-1/8 inches wide, 10-1/4 inches high and 6-3/4 inches deep.

The equipment was designed to be operated from a primary power unit consisting of a DC dynamotor requiring 24 volts at 14.8 amperes. The modulator is part of the power unit chassis. However, the power supply (MP-28B) is usually not available.

Each of the four channels has its own oscillator and each uses a type 12SK7 tube. The IPA stage consists of an 807, while the PA is composed of (2) 807 tubes in parallel. The modulator (part of MP-28B), is composed of two amplifiers, a 6N7 and a 6F6 driving a pair of 807's in PP.

(a) Filament Conversion:

The tubes in the transmitter proper are wired originally for operation from 24 volts and are in series-parallel. The first step in the conversion is to rewire these for 6.3-volt operation by placing all tubes in parallel. This can be accomplished quite easily by referring to the "before and after" diagrams given in Fig. 1. Note that since the 12SK7 type tubes have 12 volt filaments, it will be necessary to replace them with 6SK7s. If desired, the entire tube line up may be wired for 12-volt filament operation and the 12SK7's will not have to be replaced. But in this article 6.3-volt operation is assumed.

(b) Elimination of Keying Relay K101 and Substitute Circuits:

Relay K101 acted as an antenna change-over relay and switched plate voltage to the osc. and doubler in addition to other functions. As this relay operated from 24 volts DC, it must be removed and the circuit modified.

This procedure is as follows: Clip all wires to K101 and remove it from the transmitter. All of these wires may be taped up or removed, with the following exceptions: The lead from terminal 10, which is the plate voltage lead for the osc. and doubler, should be jumpered to the wire on the relay contact to which it would normally make contact when the relay operated. This will enable application of plate voltage directly to the osc. and doubler. In addition, the lead from the antenna terminal through meter M101 should be jumpered in place of the normal relay contacts. This lead will now run directly from the antenna terminal through M101 and to the swinger of S102F. (S102G is no longer used as it merely applied voltage to an external antenna loading coil relay when the transmitter was set on the low-frequency channel, number 1.) See Fig. 2.

(c) AC Power Supply and Modulator to Replace Original Unit:

As the fundamental power source was a 24-volt DC supply, it will be necessary to build an equivalent AC power supply to furnish voltages for all filaments and for the tube plates. This will have to be constructed on an external chassis. A modula-

tor capable of 100 per cent modulation is also built on the same chassis as the power supply. These two units may be wired in accordance with Fig. 3. Pay special attention to the terminal connection numbers as these will coincide with those at the transmitter.

(d) Metering Information and Keying Data:

M101 on the front panel indicates antenna current at the transmitter output terminal. The two jacks J102 and J103 provide meter connections for measuring cathode currents of the doubler and PA tubes. J103 may also be used to key the transmitter for CW use as it opens the cathode circuit of the PA.

A 22.5-volt battery is placed in series with terminal 14 along with an added metering jack to register PA grid current. See Fig. 2.

(e) Operating Data:

After connecting the power supply/modulator unit to the transmitter as shown on the diagrams, set the OSC TUNING dial for each channel to the reading corresponding to the desired frequency. The frequency calibration curves Figures 4 and 5 will permit setting the frequency to approximately plus or minus .5%. A frequency check should be made with an external frequency meter for greater accuracy.

The following tabulation shows the frequency coverage of each channel:

Channel	TA-12B	TA-12C
1	300-600 kc.	300-600 kc.
2	3000-4800	3000-4800
3	4000-6400	4800-7680
4	4370-7000	7680-12000

The switch (S2) of the power unit should be thrown to the off position, and AC applied to the power unit by closing switches S1 and S5. After a minute or so warm up period, S2 should be thrown on, applying plate voltage to the tubes. (Note: when using CW, switch S3 should be closed, shorting the secondary of the modulation transformer to prevent damage to the transformer. For phone, of course, it should be left open.)

(1) Rotate the output TUNING dial of the desired channel as far as possible in a CCW direction, thus placing the entire load coil in the circuit. Set the antenna capacitor switches (S104, 105 and 106) to the OUT position. These switches are on the same mounting board as the Channel 1 loading switches. (2) Set the plate capacitor switches (S109, 108, 107) to the OUT position. These are accessible when the transmitter is removed from its case. Set the output loading coil of the desired channel to 50, which corresponds to maximum capacitance. (3) Connect an antenna to the antenna terminal (115 feet of straight wire will work very well.) (4) Set the channel selector to the desired number and close the telegraph key, which can be plugged into J103. Rotate the channel loading dial from 50 to 0 observing the PA plate current. (A meter will have to be placed in series with the key to observe this.) Rotate the channel TUNING control and channel LOADING control until a dip in PA plate current is noticed. A setting should be found which will give a dip in plate current to approximately 180 ma. To obtain proper loading it may be necessary to connect the fixed plate capacitor in parallel with the variable by means of the switch (S109, 108, 107) on the rear plate of the coil and capacitor assembly. It may also be necessary to connect the antenna series capacitor in the circuit by means of S104, 105 or 106. The antenna current as indicated by M101 should pass through a peak at approximately the same tuning point that gives minimum plate current. It is possible to tune to a harmonic of the desired frequency, so a wave-

meter should be used at all times as a check on the output frequency.

(f) General Notes:

The test key on the front panel may be wired in series with J103 if desired and used for tuning purposes, allowing a meter to be plugged into J103.

It may be advisable to insert an r-f choke in series with the B plus lead to the transmitter final tank coil. This lead should be by-passed to ground.

Schematic circuit diagrams of the transmitter and original power supply unit are given in Figs. 6 and 7.

With this conversion it will not be possible to make use of the remote control unit, due to the lack of 24 volts DC for operation of the control motors.

TA-12 (B&C) FILAMENT CIRCUIT

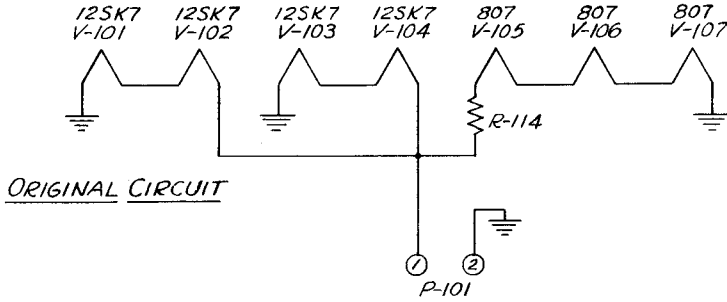
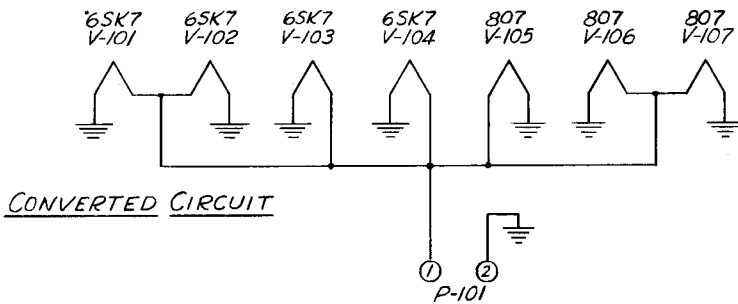

fig 1



CIRCUIT SUBSTITUTION FOR RELAY K-101

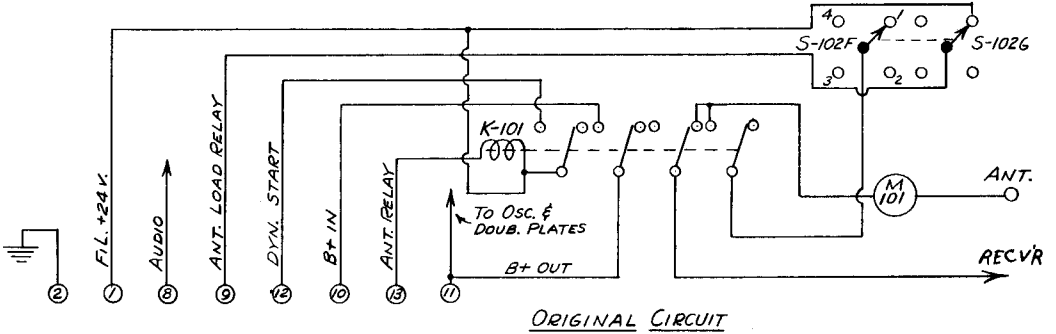
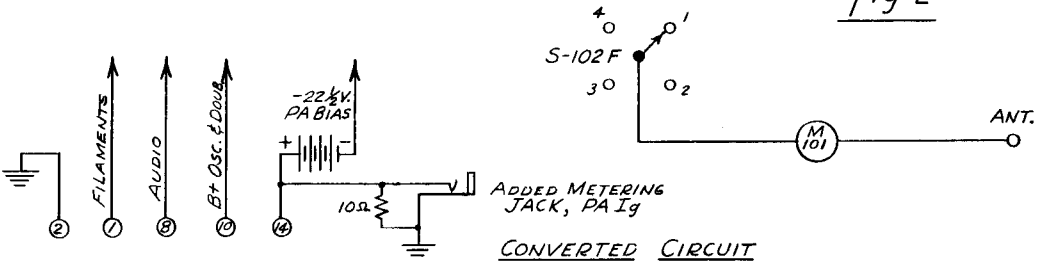
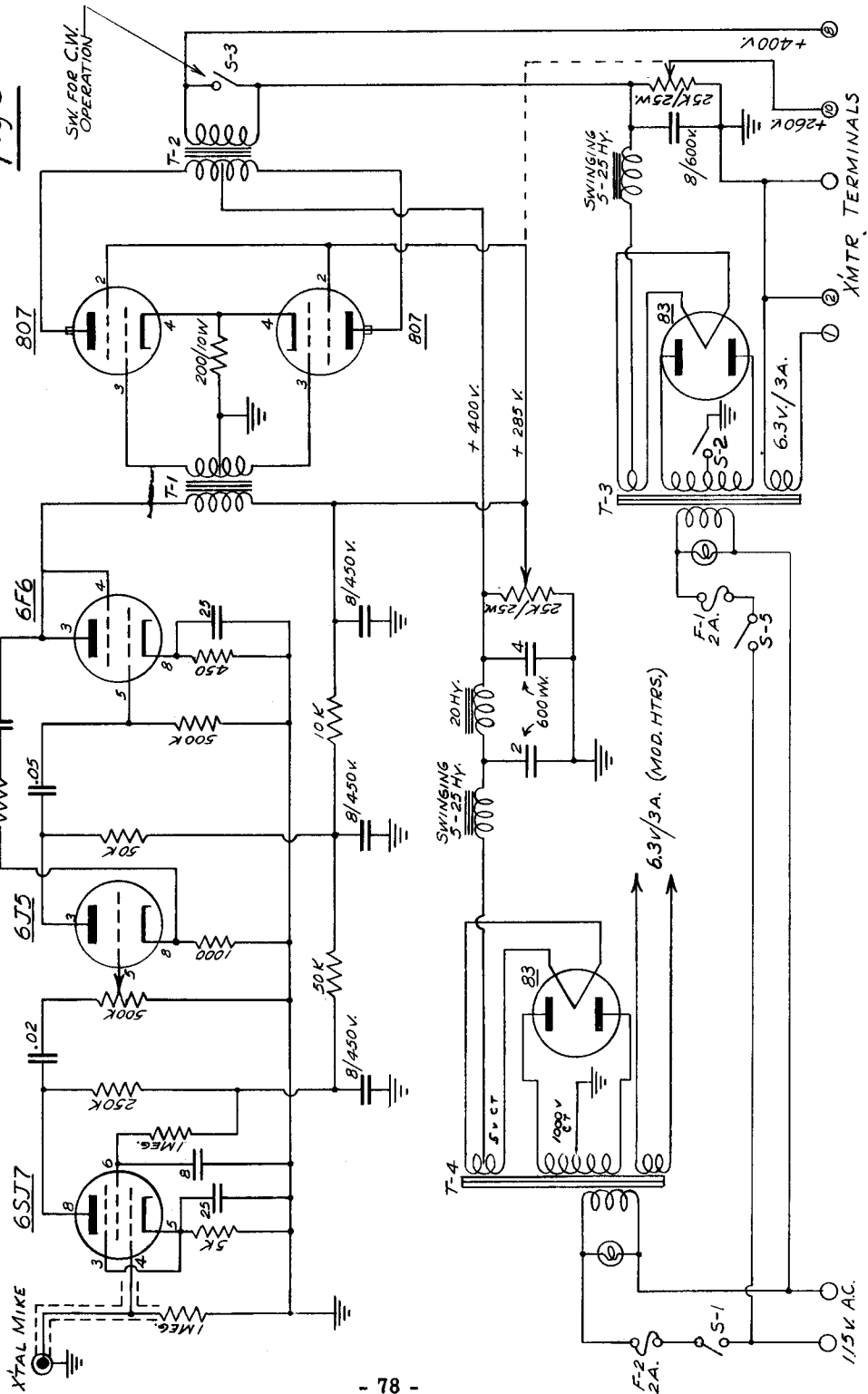

fig 2



MODULATOR AND POWER SUPPLY FOR TA-12 TRANSMITTER

fig 3



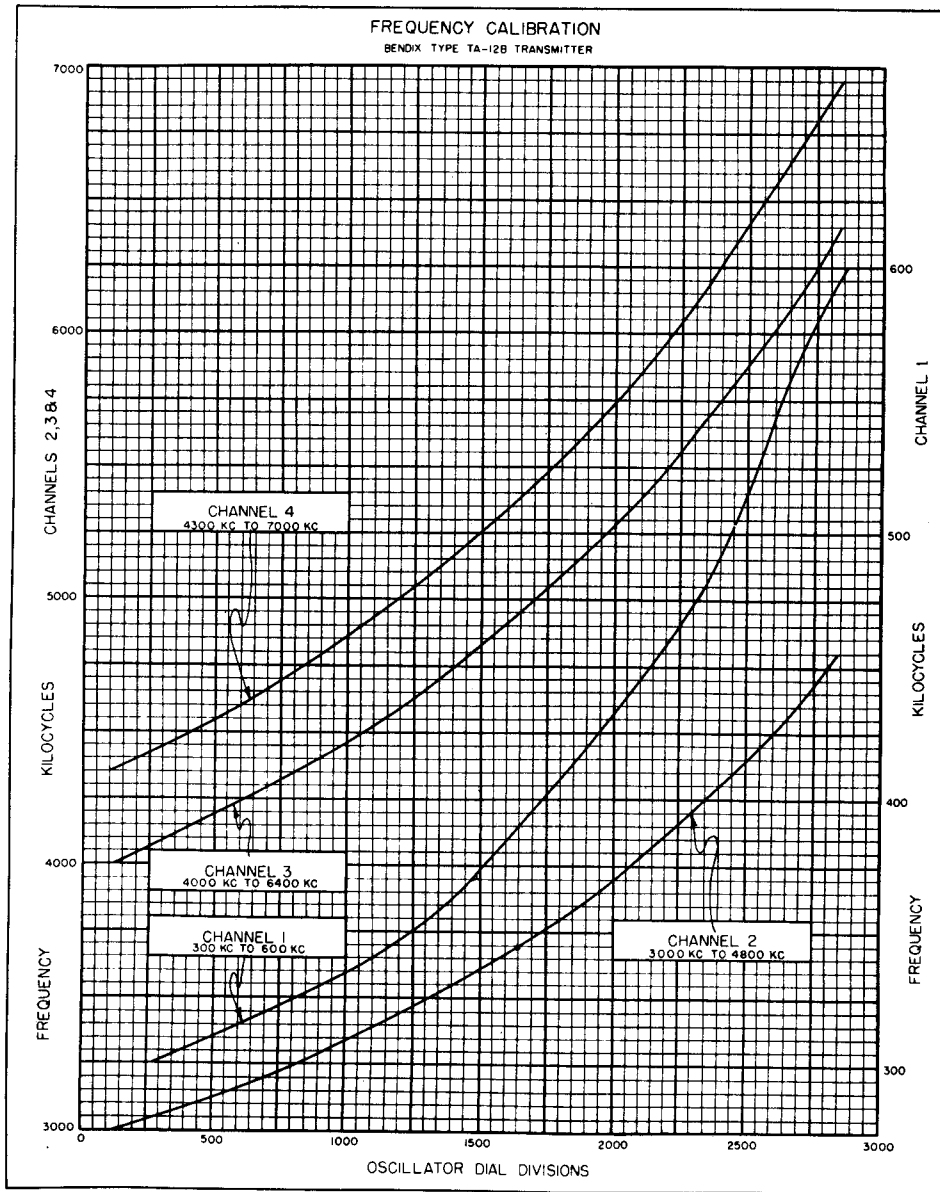

FIG. 4 - FREQUENCY CALIBRATION TYPE TA-12B TRANSMITTER

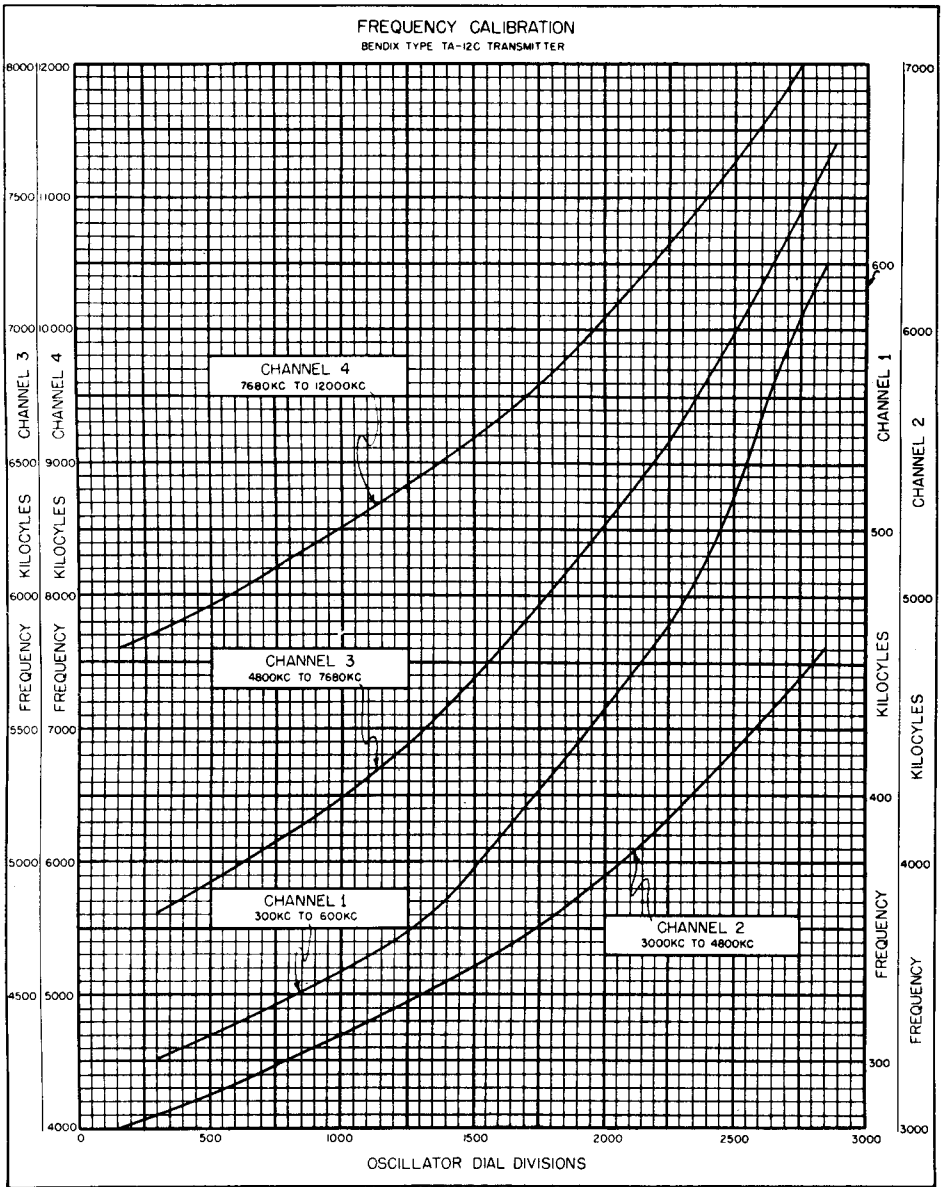
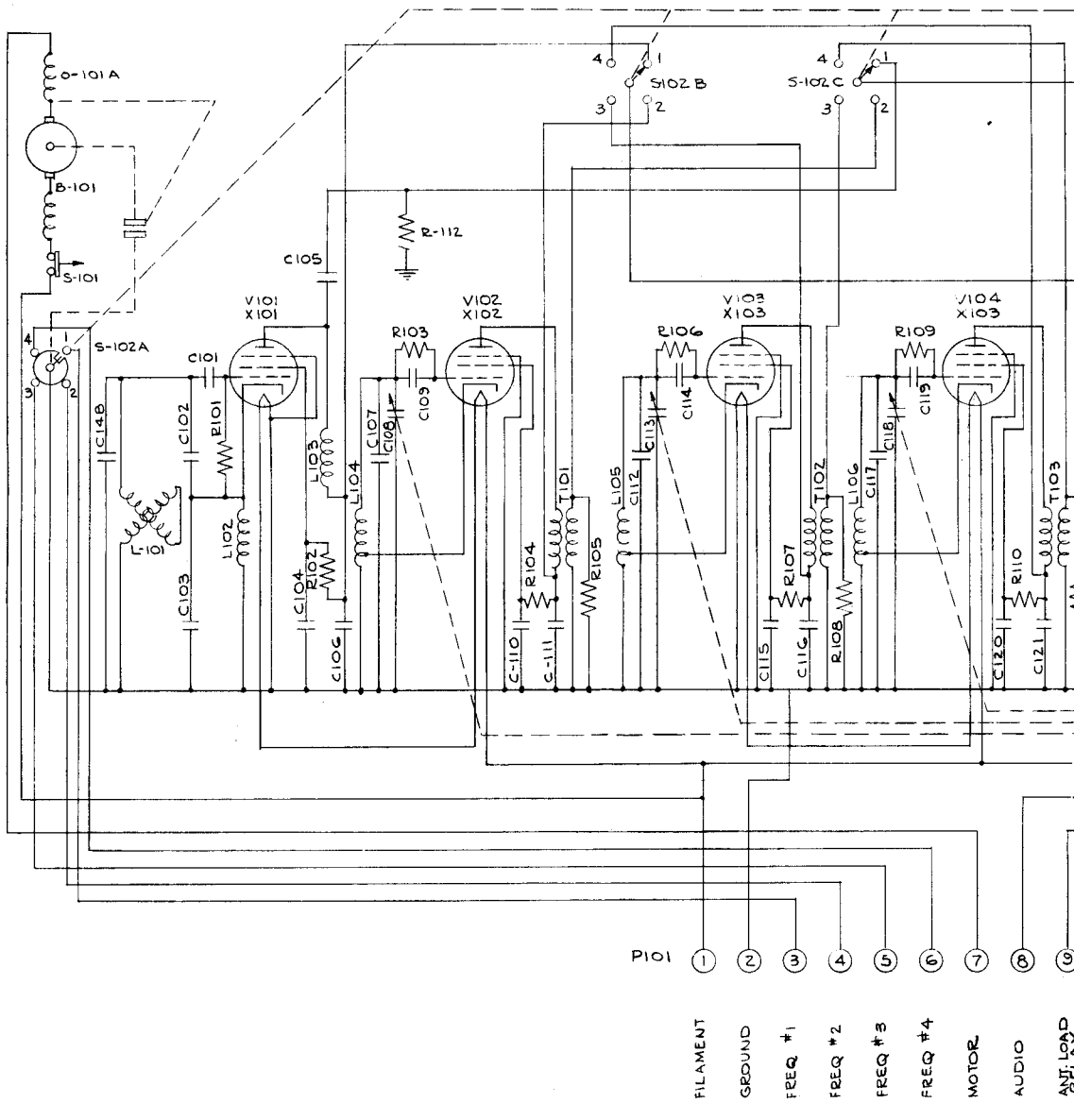
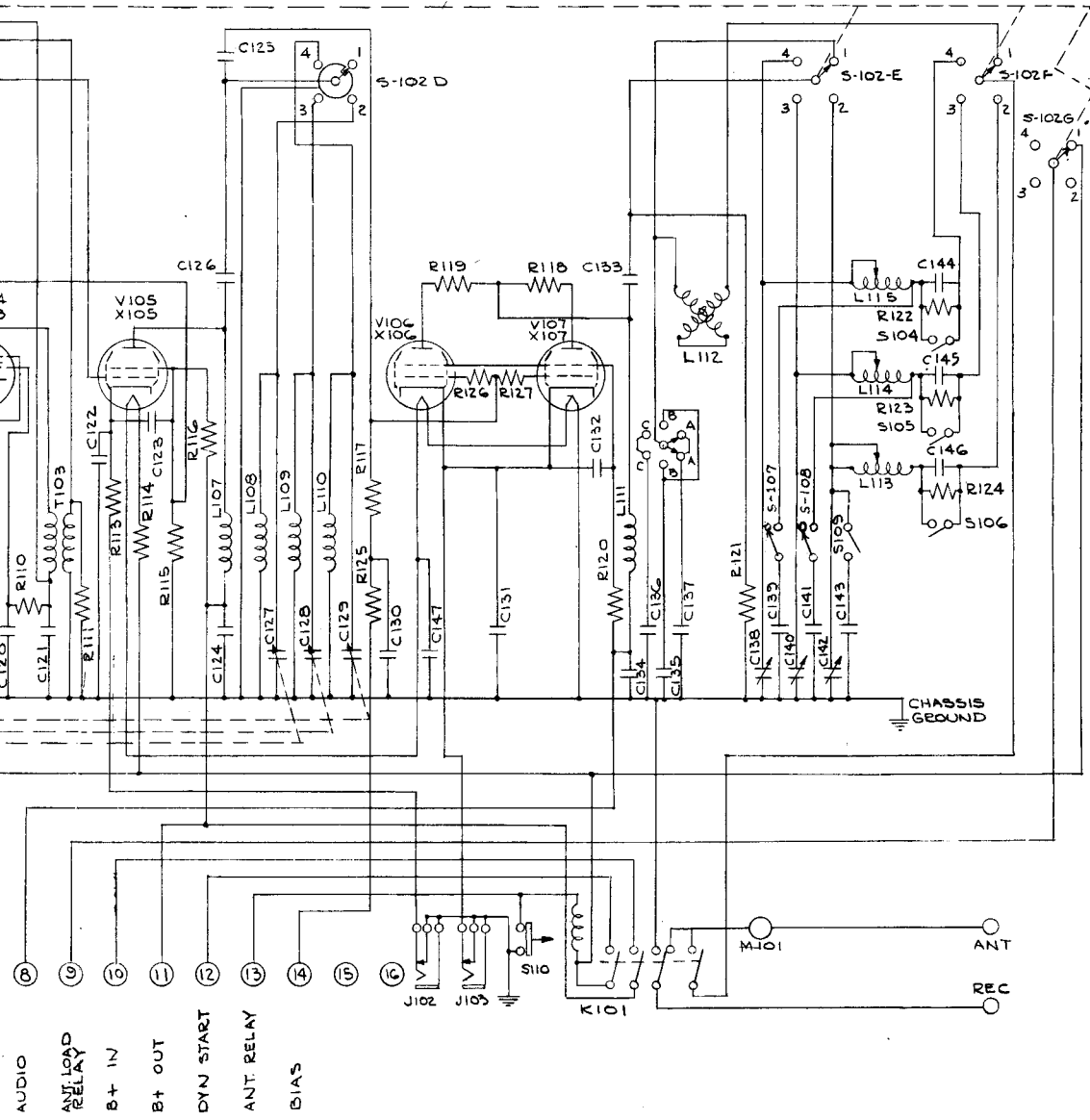

FIG. 5 - FREQUENCY CALIBRATION TYPE TA-12C TRANSMITTER



TA-12
(FIG 6)



- 8 AUDIO
- 9 ANTI-LOOP RELAY
- 10 B+ IN
- 11 B+ OUT
- 12 DYN START
- 13 ANT. RELAY
- 15 BIAS

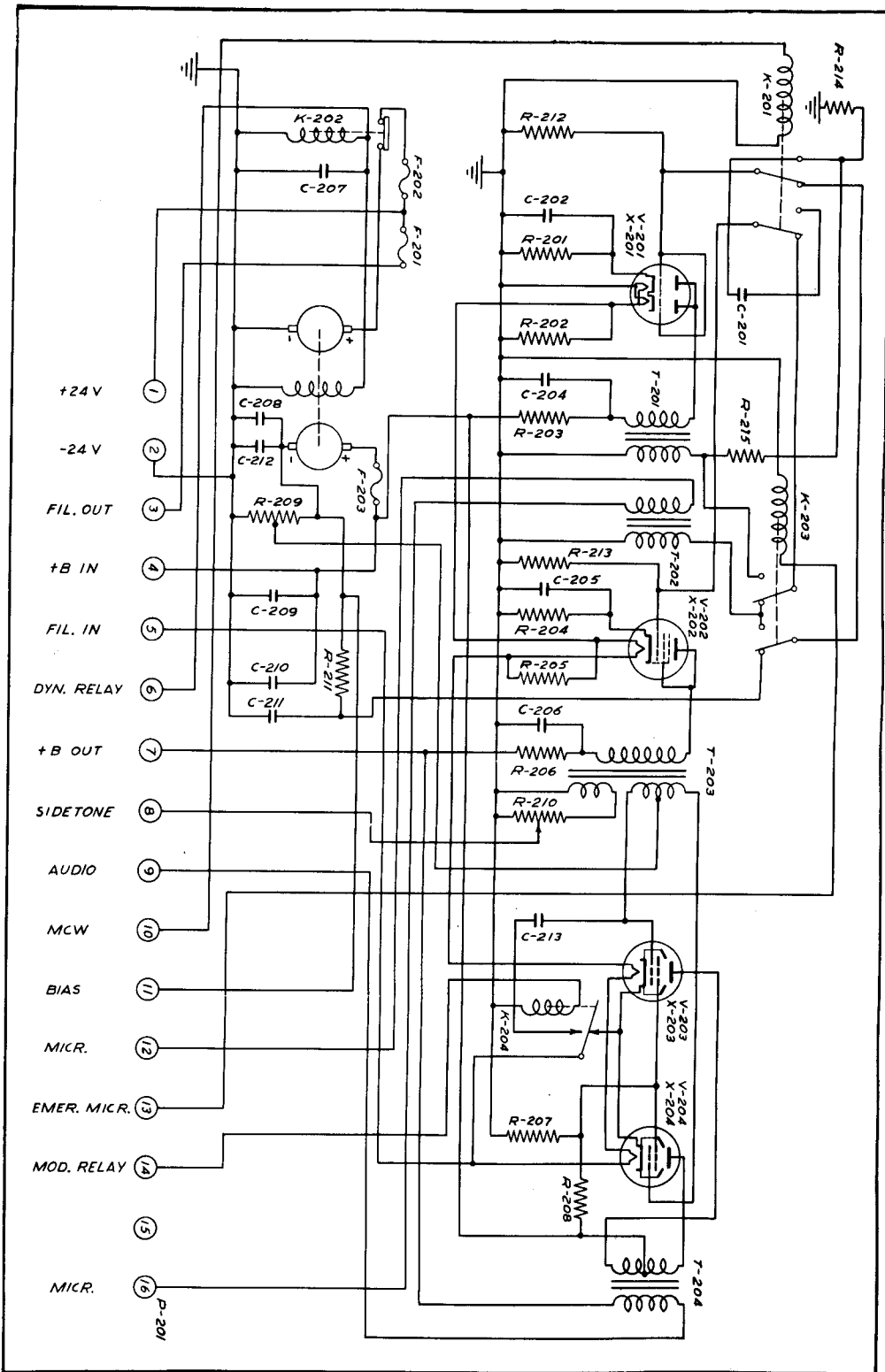
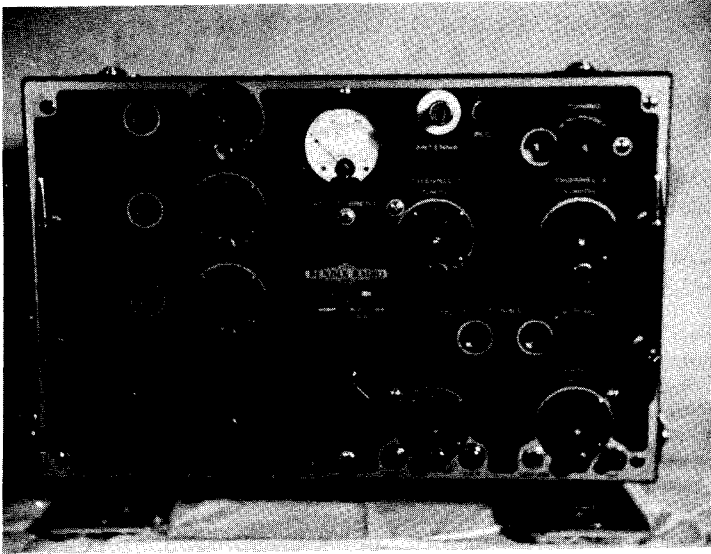
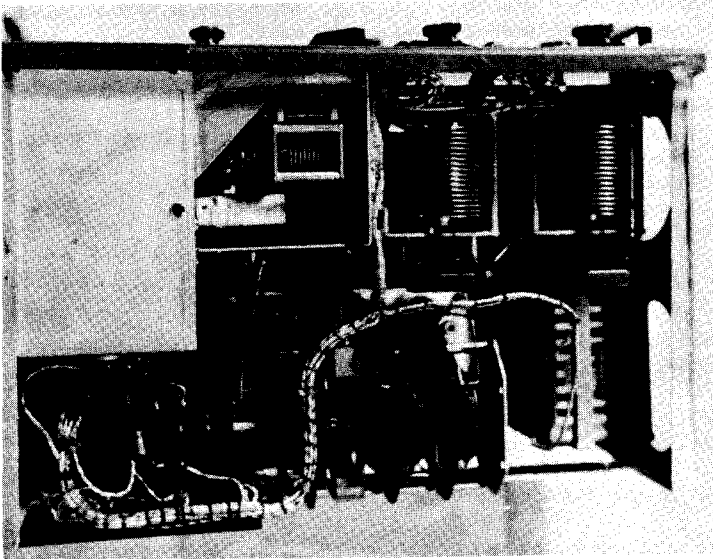

FIG 7 - SCHEMATIC DIAGRAM TYPE MP-28B POWER SUPPLY UNIT



TA-12B Transmitter



TA-12B Bottom View After Conversion

FIG. 8

CONVERTING THE AN/ART-13 OR (ATC) AIRCRAFT TRANSMITTER

The Collins ART-13 Autotune Transmitter and its Naval counterpart, the ATC, were designed for use in the larger types of Army and Navy aircraft. They are now available on the surplus market in limited quantity.

This unit is truly the answer to the desire for a beautifully versatile rig covering all the amateur bands between 2000 and 18,100 kc. By simple conversion the 10-meter band may be added. Provision is made in the design for addition of a unit to cover the range of 200 to 1500 kc. But, as this range is useless for amateur operation, the space allowed for this section may be used for the addition of a 10-meter stage.

Phone or CW may be used with about 200 watts input to the final. Monitoring circuits are built into the set for both. CW speeds up to 25 WPM are possible. However, if higher keying speeds are desired it is suggested that block-grid keying of the final amplifier be used.

Probably the most noted characteristic of this transmitter is the autotune mechanism which allows selection of any one of 11 preselected frequencies, pre-tuned and ready to operate approximately 30 seconds after the selector dial is set to the channel desired. This mechanism may also be set into operation from a remote position by means of a separate control box, allowing the transmitter to be installed in a basement or garage and yet operated from within the house. In addition, a frequency-meter type VFO is incorporated. A crystal calibrator is included to check the calibration of the VFO.

The transmitter is only slightly larger than the standard communications receiver and weighs just 70 lbs. It is of rugged construction and looks well enough to be placed in the most particular ham shacks. It is housed in a black wrinkled aluminum cabinet 23-5/8 inches wide by 16 inches deep and 11-3/8 inches high. Provision is made for use with a shock-mount base.

The tube complement is as follows:

- 1 - 837 electron coupled oscillator
- 1 - 1625 (12 volt 807) doubler, tripler or quadrupler, depending upon frequency desired
- 1 - 1625 tripler
- 1 - 813 power amplifier
- 1 - 12SJ7 speech amplifier
- 1 - 6V6 driver
- 2 - 811 modulators
- 1 - 6V6 sidetone audio amplifier
- 1/2 - 12SL7-GT calibration-crystal oscillator
- 1/2 - 12SL7-GT frequency tripler
- 1/2 - 12SL7-GT calibration detector
- 1/2 - 12SL7-GT tone oscillator
- 1 - 12SA7 mixer (in frequency divider)

(a) AC Power Supply for the Equipment:

The main problem in converting this transmitter is in constructing a power supply so that the equipment may be operated from the standard 115-volt a-c line. In fact, if operation on the 28 Mc. band is not required, the construction of the power supply is all that is required before placing the transmitter on the air. On the basis of the conversion of a number of these excellent transmitters it has been concluded that the most satisfactory method of constructing the power supply is that method which requires no modification or extensive disassembly of the transmitter.

To meet the above requirement it is necessary that the power supply furnish the

following voltages and currents:

27 volts d.c. at 10 amperes
400 volts d.c. at 225 ma.
1250 volts d.c. at 250 ma.

The 27-volt d-c power supply lights all filaments and heaters and the pilot lamp, powers all relays, and operates the autotune mechanism. The 400-volt power supply runs the v.f.o., exciter, crystal calibrator, speech amplifier, and in addition supplies screen voltage to the 813 final amplifier. The 1250-volt power supply provides plate voltage for the 813 when operating on c.w., and in addition supplies plate voltage to the 811 modulators when operating on phone.

Figure 1 shows a complete power supply for the transmitter. A bridge selenium rectifier is used for the 27-volt supply, while mercury-vapor rectifiers are used for each of the other power supplies. Choke-input filters are used in all three of the power supplies. The 12.5-ohm resistor in series with the negative return for the high-voltage power supply will give a full-scale reading of 320 ma. when the meter-selector switch on the panel of the ART-13 is placed in the "P.A. PLATE" position. The lead to terminal 7 of the ART-13 power plug is not used. This lead was used in the aircraft installation to turn the equipment on. With this power supply the equipment is placed into operation by closing the main switch in the 115-volt a-c line. Note that a separate switch has been provided for turning off the high-voltage supply when tuning the transmitter or checking frequency; the low-voltage system operates normally with this switch turned off, but no high voltage is applied to the 813 or to the 811's. Always be sure that the "CALIBRATE-TUNE-OPERATE" switch on the transmitter is in either the "CALIBRATE" or the "TUNE" position when tuning or calibrating the transmitter. If this is not done, damage to the screen of the 813 may occur as a result of excessive screen dissipation. With the power supply circuit as shown, the plate-voltage supplies will be in operation at all times when the "VOICE-CW-MCW" switch is in either the "CW" or "MCW" position, although the "MCW" position of course will not be used. For this reason S₂ has been included to provide for control of the application of plate voltages to the transmitter from the operating position.

(b) Adding the 10-Meter Multiplier:

The upper frequency limit of the ART-13 transmitter is 18.1 Mc. Hence the inclusion of an additional multiplier is necessary if operation on the 28-Mc. band is desired. This multiplier may be mounted in the space in front of the 813 tube which was provided for the low-frequency oscillator. A metal shelf or subchassis is installed in this space. A power plug which carries all necessary voltages for the added stage is already provided in the compartment. A 1625 tube is used for the added stage since its filament may be connected to the power plug after the 28-ohm resistor is removed from the circuit. This resistor was provided to give the same drop as the 1625 tube for which it substitutes when the low-frequency oscillator is not used. The circuit of the stage is given in Fig. 3. A variable condenser across the plate coil of the 1625 may not be required. Tuning is broad and may be accomplished by decreasing or increasing spacing between the coil windings. The stage may be operated either as a doubler or tripler, but in this particular conversion a tripler appeared to give much better results. Coil data for a tripler stage is given in Fig. 3.

A 10-meter final tank circuit must also be constructed. The coil is best mounted on the relay K-105 located just to the left of the new 10-meter compartment as viewed from the front panel. This relay, K105, originally switched the 813 plate to an external loading coil for low-frequency operation. The 10-meter tank circuit is merely hooked between the relay output contact and ground. Coil

data is given on the 10-meter circuit diagram Fig. 3. In these units it is advisable to remove the low frequency RF choke L-109, and move C-128 (.002) into the former position of L-109. The high-voltage lead is then connected to one side of C-128 and to the bottom of the high-frequency choke, L-108. The other side of C-128 is grounded. The 10-meter antenna connection can now be made to the external load-coil terminal if a lead is run from the load coil terminal to a tap on the 10-meter tank.

To switch from 10-meter operation to any one of the other frequencies, two methods may be used. The first method allows fully automatic operation and uses a double pole, double throw relay mounted on the panel in the bottom of the transmitter near the grid of the 813. Activation of this relay is accomplished by the same current source which supplies the external antenna change-over relay. The second method involves the use of a four-pole double-throw switch mounted near the grid of the 813 and wired according to Fig. 3. Both methods merely break the lead from the multiplier stage plate to the 813 grid and connect either the 10-meter multiplier section or the normal HF oscillator to the 813.

For 10-meter tuning, the transmitter controls "A" and "B" are tuned in the normal fashion to 1/3 of the required 10-meter frequency. Controls "D" and "E" are not important but control "C" should be placed on position 7 to close the internal switch in series with the key and to short out the HF pi-network coil.

After switching to 10-meter operation, turn on the transmitter and tune the tripler for a maximum reading of 813 grid current with the meter switch in the "Tune" position and the emission switch in the CW position. The 813 tank is then tuned for minimum plate current.

(c) Autotune Mechanism:

To tune manually, the locking bars are left tight and the channel switch turned to "Manual". After the mechanism has stopped, the knobs are set as stated in the calibration book and the transmitter is tuned normally.

To preset a channel, turn the channel switch to the number desired. When the mechanism stops, the locking bars are loosened and the transmitter tuned normally. The knob positions are noted and turned CCW 1/4 turn and then returned to the position noted. The bars are locked while holding the knobs in position. This channel is now preset the another can be set up.

(d) Calibration Instructions:

The internal crystal-controlled calibration oscillator provides an accurate (within .01%) check point every 100 to 600 kc. This is accomplished by zero-beating the master oscillator with the output of the crystal-controlled calibration oscillator at the nearest check point given in the calibration book. Then the "B" dial pointer is moved to correct the dial reading at the check frequency. A 200-kc. crystal is used as the controlling standard. The "Calibrate-Tune-Operate" switch must be in the "Calibrate" position during this operation.

(e) Operating Notes:

One feature of this transmitter which may be disturbing is the possibility of tuning to a harmonic of the desired frequency. The remedy for this is to note the dial readings when you are positive of the frequency and suspect any great deviation from these readings at later dates. Meter readings cannot always be relied upon and a simple absorption-type wavemeter will come in very handy when in doubt. Also, MCW operation is legal only on the 11-meter band.

(f) Microphone Data:

The transmitter is designed for use with a low-resistance (40-ohm) carbon microphone or a high-output 200-ohm dynamic microphone, neither of which is readily available. A much better arrangement may be had by rewiring the microphone switch as shown in Fig. 4. R-201, 202, 203 and 204 are removed, along with C-201. If it is desired to use a high-impedance dynamic mike or crystal mike, a speech amplifier stage will have to be built into the space occupied by T-201 and associated parts. This stage may be a 6J5 used in the conventional manner.*

(g) Cooling:

Due to the unusual compactness, this transmitter will operate quite warm. In the event that better cooling is required, the rear plate behind the 813 compartment may be removed. Alternatively, a small blower or fan can be mounted on the rear panel of the transmitter.

(h) General Notes:

A time-delay relay may be advantageous in the power supply to prevent plate voltage from being applied before the tubes have heated up.

It is important to note that when the "Emission" switch is in the "Off" position, it doesn't remove the power when the AC power supply is used. The switches shown in the power unit diagram must be used.

Two antennas will probably be used and, for all bands except 10 meters, a long wire 118 feet long and tapped 16 feet from the center will function very nicely. For 10 meters, a dipole or a rotary array may be fed in the conventional manner.

Full-scale meter readings on the ART-13 are:

Position:	Full Scale Reading:
Battery Voltage	54 volts (28 volts in marked position)
PA Grid	17 ma.
PA Plate	320 ma.

Tuning should always be done in the CW position so that meter readings obtained will not include the current drawn by the modulator tubes. Static in the modulator is about 40 ma.

* For information on this added stage, and for other information on the conversion of the ART-13 transmitter, see "RADIO HANDBOOK" 11th edition, pages 437 and 444.

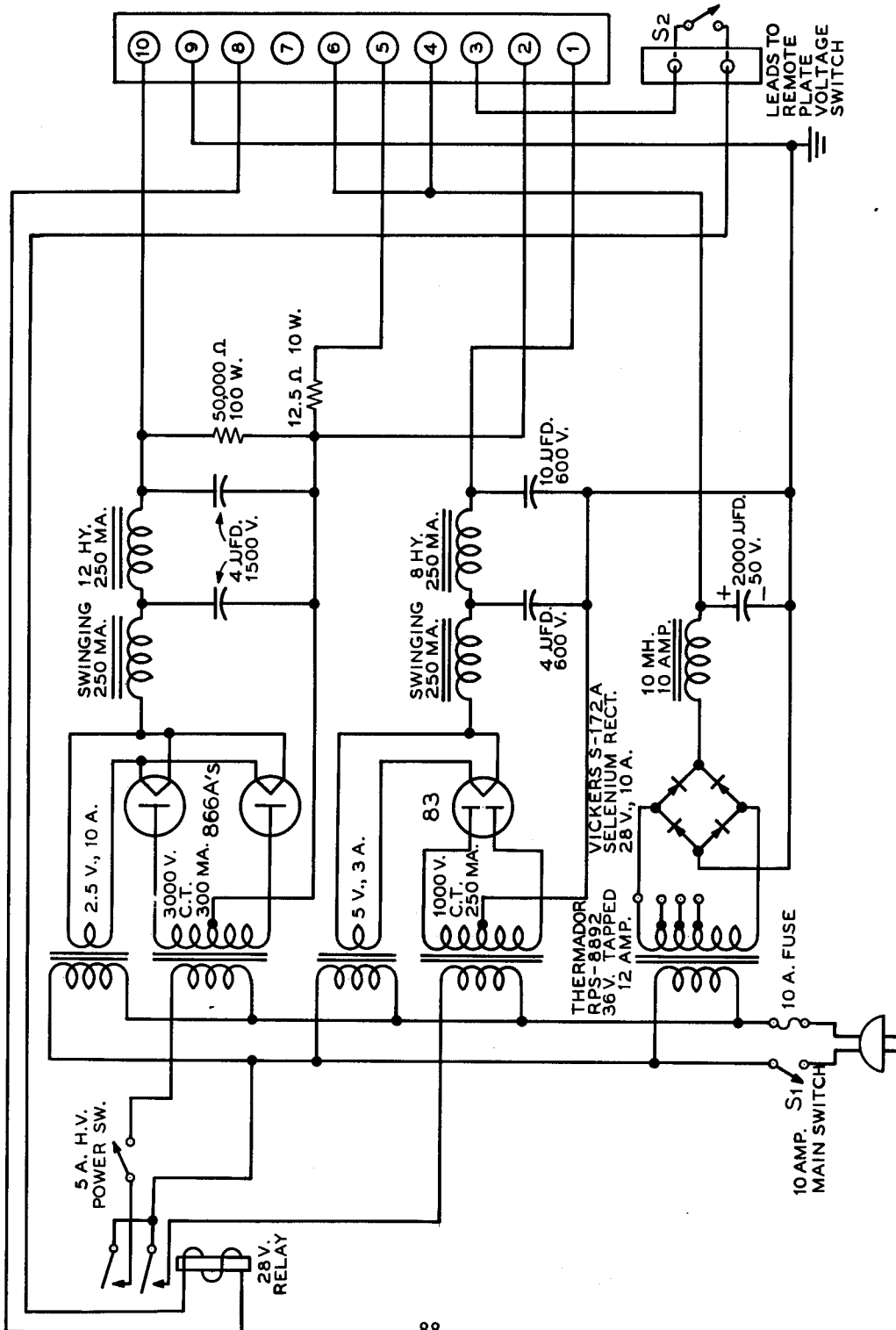

ORIGINAL FILAMENT OF ART-13 TRANSMITTER

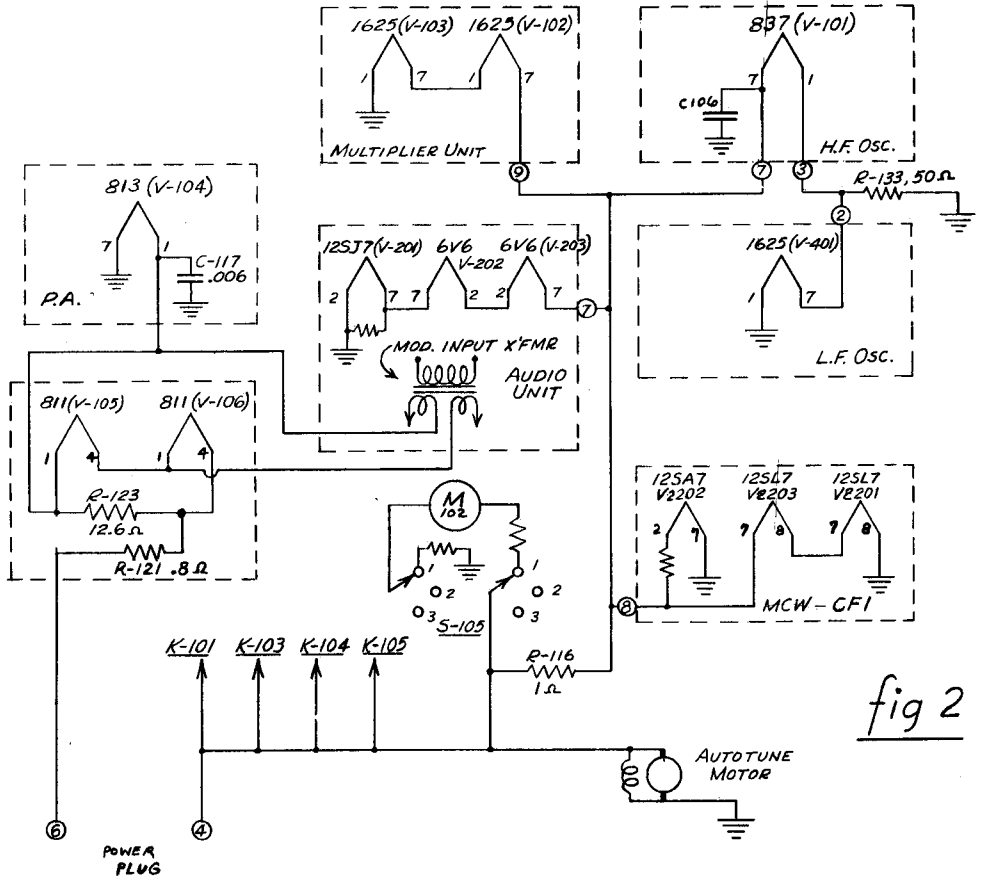

fig 2

ART-13 MICROPHONE SWITCHING CIRCUIT

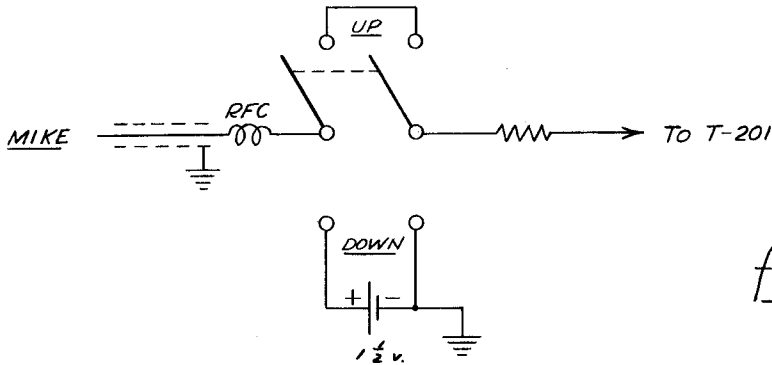
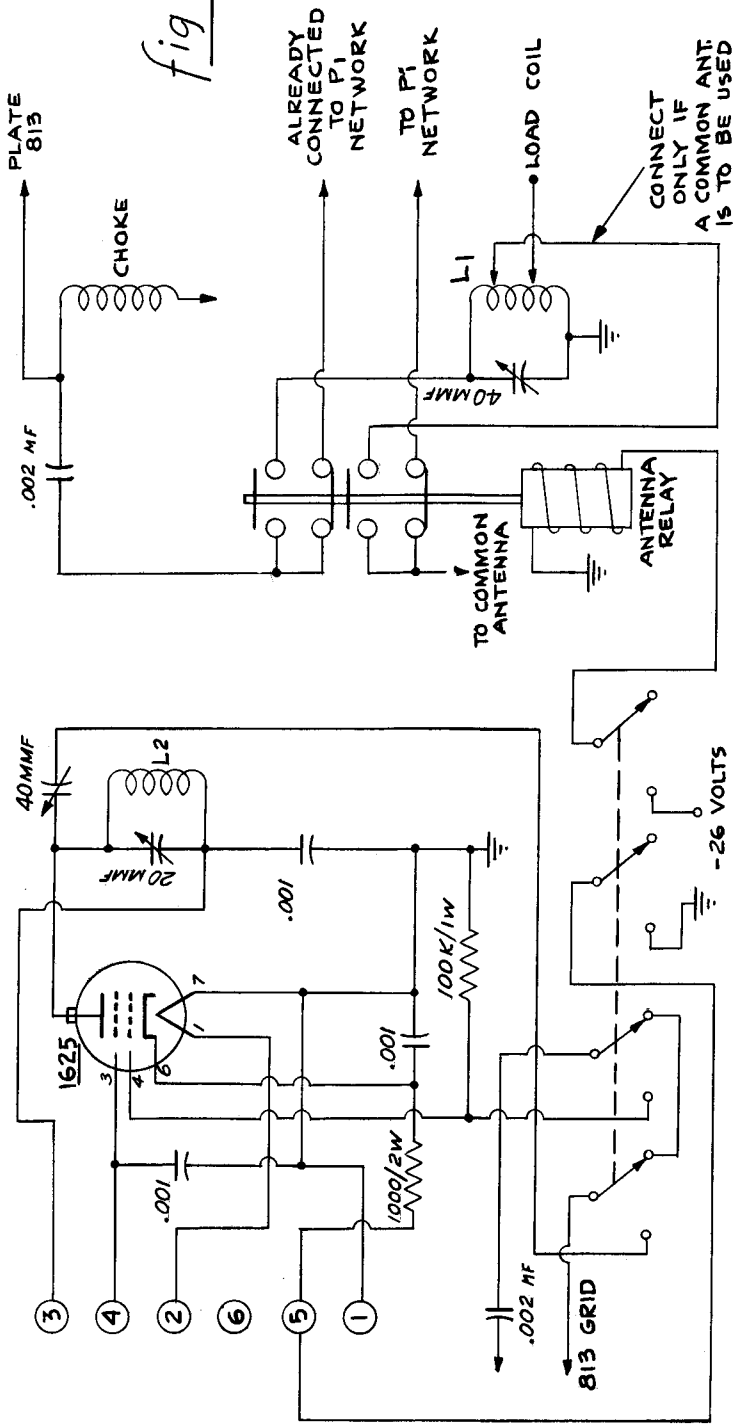

fig 4

ART-13 10-METER SECTION

fig 3



L-1 5 TURNS NO. 10 ENAMEL 1 1/2" DIA. / 1 1/2" L.
 L-2 5 TURNS NO. 12 ENAMEL 1 1/2" DIA. / 1 1/2" L.

REAR

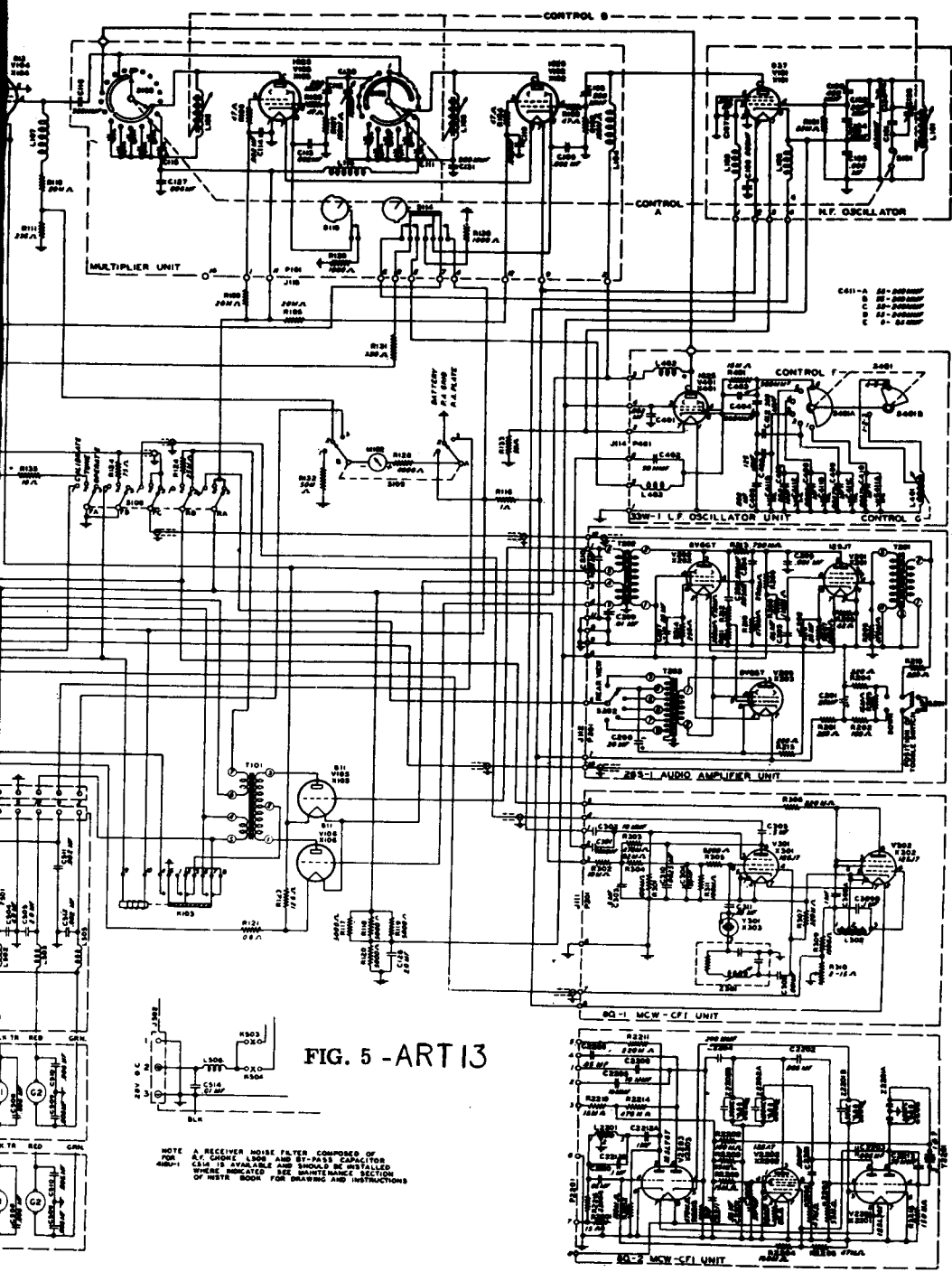
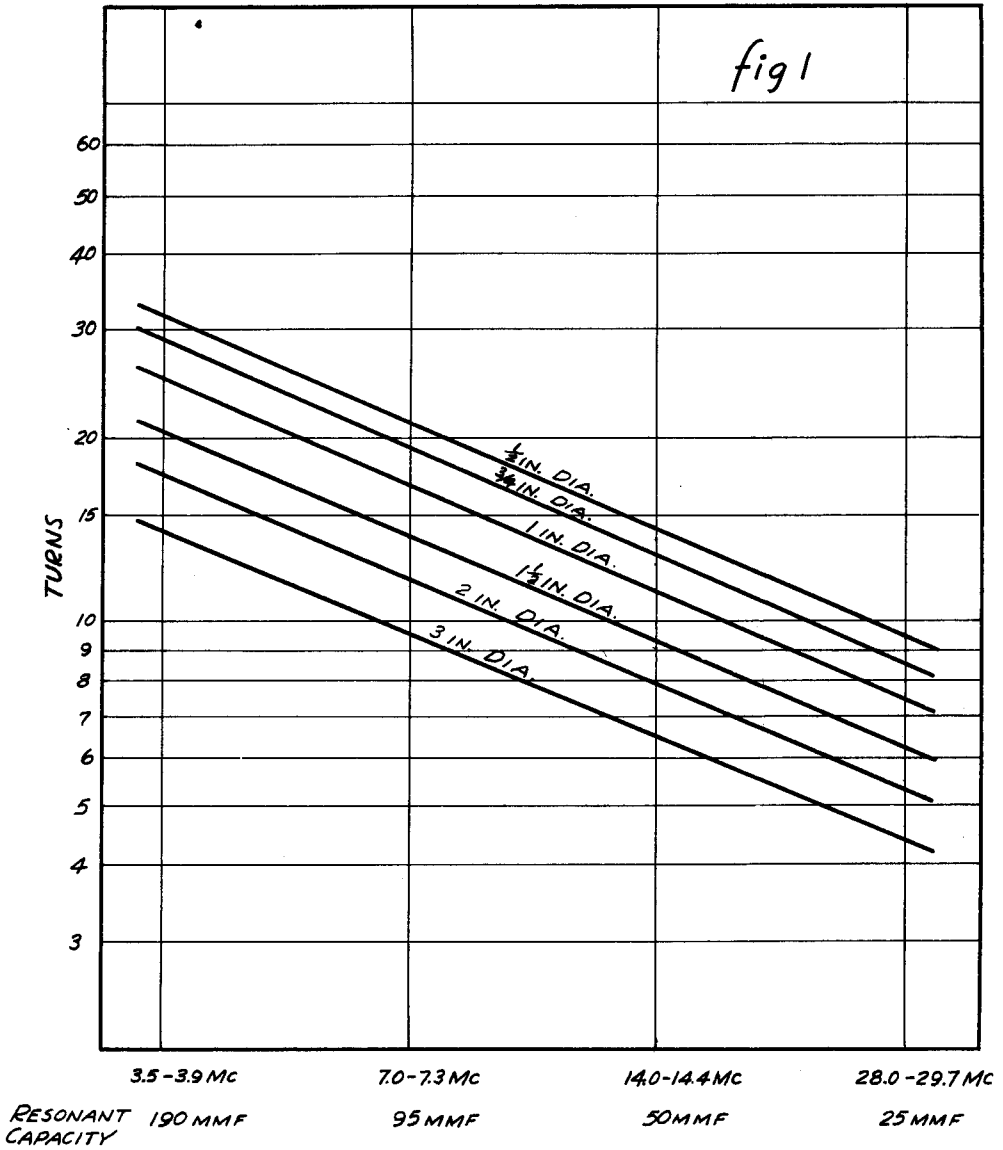

FIG. 5 - ART 13

NOTE A RECEIVER NOISE FILTER COMPOSED OF
 A 1/2" CROWN LENS AND 51-PASS CAPACITOR
 CAN BE AVAILABLE AND SHOULD BE INSTALLED
 WHERE INDICATED SEE MAINTENANCE SECTION
 OF INSTR. BOOK FOR DRAWING AND INSTRUCTIONS

COIL TURNS V.S. FREQUENCY BANDS
 (COIL DIAMETER = COIL LENGTH)



SIMPLIFIED COIL WINDING DATA

It is frequently necessary to wind new coils in the conversion of surplus equipment as well as in the construction of standard communications items. These coil-winding charts were devised as an assistance to those persons who occasionally do have need to wind a coil of relatively standard dimensions. The curves are plotted in terms of the major amateur bands and in conjunction with the resonant capacitance which will give a moderate value of Q under average operating conditions.

The curves of figure 1 and figure 2 are derived in each case for a specified diameter-to-length ratio. The resonant capacitance quoted includes the stray circuit and tube capacitances which exist in the circuit. The curve "Turns per inch for common wire sizes" is included as a guide in determining the length which will be required for a specified number of turns for these wire sizes.

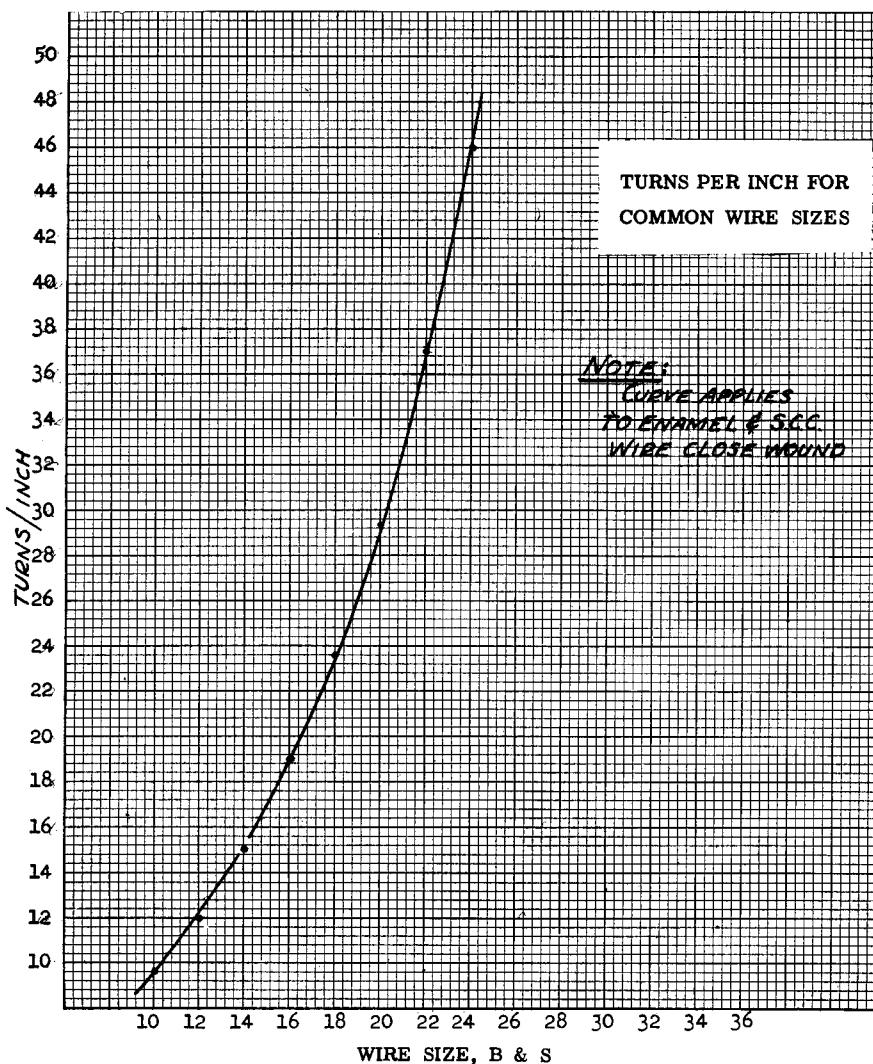

COIL TURNS VS. FREQUENCY BANDS
 (COIL LENGTH = $1\frac{1}{2}$ COIL DIAMETER)

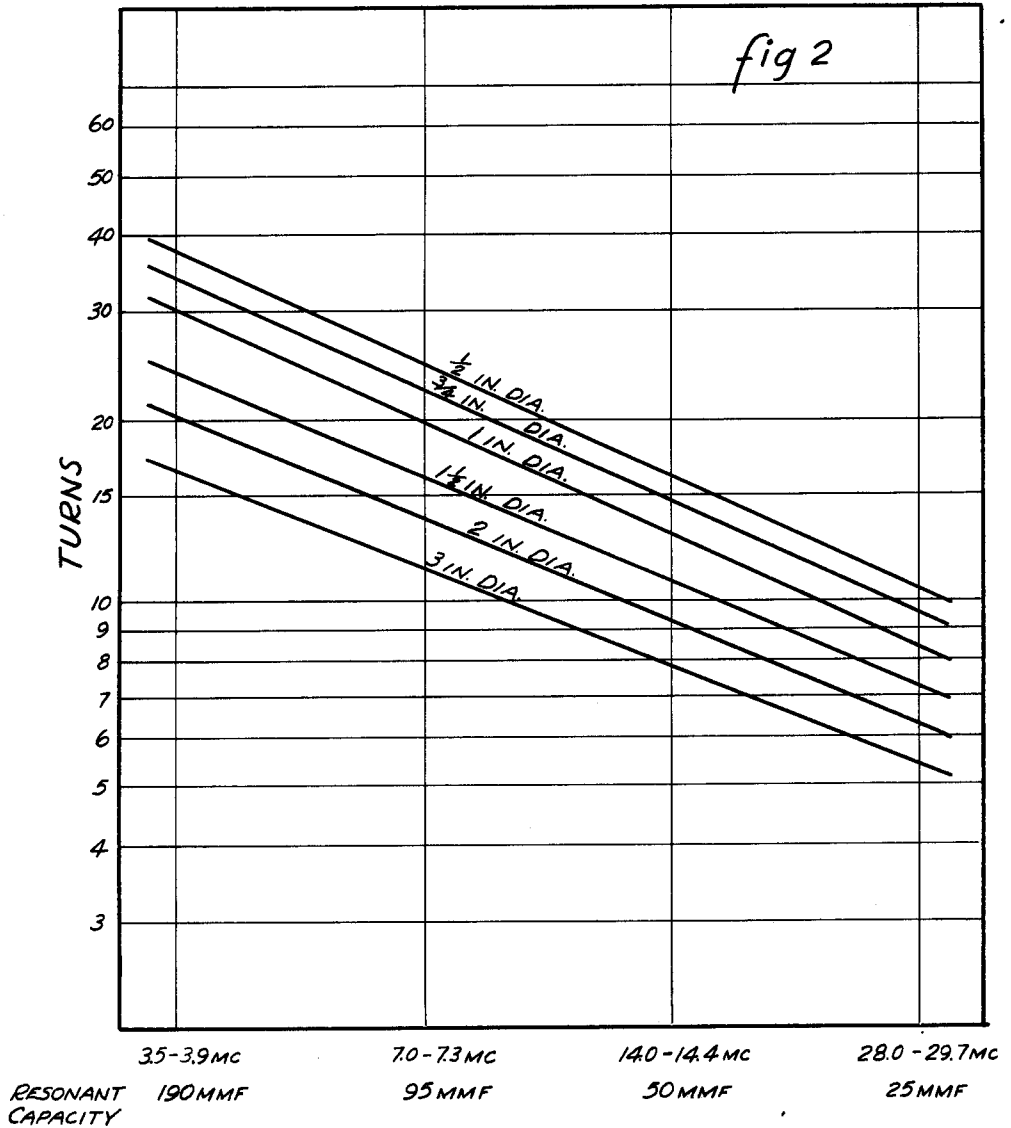

RADIO EQUIPMENT FOR LIGHT AIRCRAFT EMPLOYING THE AVT-112A TRANSMITTER

The surplus market has made available a radio equipment, appropriately small and light weight, that is readily adaptable to light aircraft installation. Modification problems are generally quite simple. The complete radio installation may be made at a fraction of the cost of similar equipment on the standard market.

As is apparent to persons connected with the operation and servicing of aircraft, any installation of radio equipment must be subject to CAA inspection and thence operated only by personnel properly licensed by the FCC.

(a) Description:

The AVT-112A transmitter, specifically designed for light-aircraft use, provides reliable radio-telephone and CW transmission over moderate distances on any frequency within the band of 2500 to 6500 kc. It is a crystal-controlled unit capable of delivering 6 to 7 watts of RF power to the antenna. The AVT-112 is 5-3/8" high, 6-1/4" wide, 4-7/8" deep, and weighs 6 pounds.

The unit operates from a 6, 12 or 24 volt source in conjunction with its associated plate voltage power supply which is a separate unit in the installation.

Six tubes are employed in the transmitter as follows:

6V6	Pierce crystal oscillator
6V6	Power amplifier
(2) 6V6's	Modulator (push-pull)
6AF6	Dual type, tuning indicator
6SL7	Tuning Indicator amplifier

The crystal oscillator circuit is of the untuned Pierce type which does not require tuning adjustment regardless of the crystal frequency used. For convenience and quick change of crystals, the crystal holder is located on the front panel of the transmitter. The holder is designed to accommodate the following types of crystals: AVA-10, AVA-53, MI-8412, VC-2, and Signal Corps type FT-243.

A single-ended 6V6 stage is used as the power amplifier and is modulated by a pair of 6V6's operating push-pull. The modulator grids are driven directly by a carbon microphone through a mike-to-grid transformer. Excitation for the microphone is obtained from a tap on the 6V6's common cathode resistor.

Tuning adjustment of the PA and antenna loading is accomplished by the use of the dual electron eye indicator on the front panel. Its two sectors indicate the relative PA cathode current, antenna current, and modulation level. No other metering is required for tuning adjustments. However, actual PA plate current may be determined from a meter plugged into the jack located on the back of the transmitter unit.

In addition to the antenna loading and antenna coupling controls, a loading selector switch provides the required loading adjustments to match most conventional type antennas including the fixed "V" and the trailing wire type. The antenna circuit is also provided with an antenna switching relay which permits receiver use with the same antenna.

An intercommunication system which utilizes the modulator as an AF amplifier is incorporated in the transmitter unit. The intercom system is switched into operation by the fourth position of the antenna selector switch. When in this position, the radio portion of the transmitter is completely disabled. All connections to the transmitter, with the exception of the microphone, are made from the rear of the unit.

(b) Adjustment and Operation of the AVT-112:

After installation with an appropriate power supply, the desired crystal installed, and the microphone plugged in, the transmitter is ready for initial operation adjustments. Approximately 30 seconds warm-up time for the filaments should be allowed before operating.

Tuning adjustments for the AVT-112 fall into two phases: PA tuning, and loading the transmitter to the antenna. These adjustments should be done in the following manner to insure proper operation:

PA Tuning

- (1) Set Selector Switch (B) to position 3
- (2) Set "Ant. Load." coarse (C) and fine (D) controls to position 1
- (3) Set "Ant. Coup." (E) to position "O" (extreme counter-clockwise)
- (4) Adjust "PA Tuning" (A) to resonance as indicated by minimum shadow angle on lower sector of tuning indicator tube, and lock. (If two resonant points exist, select the lower frequency which will be the fundamental.)

Loading Transmitter to Antenna:

This adjustment should be made while airborne.

- (1) Set "Selector Switch" (B) to,
Position 1 (trailing antenna, all frequencies)
Position 2 (fixed antenna, low and medium freq.)
Position 3 (fixed antenna, medium and high freq.)
- (2a) Adjust length of trailing antenna for maximum shadow width on top sector of tuning indicator with "Ant. Coup." (E) set at approximately 30 (dial reading). Readjust both antenna length and "Ant. Coup." for maximum shadow angle on tuning indicator. Note the following approximate antenna lengths versus frequency to aid in antenna adjustments:

Frequency	Approx. Total Length
3000	75 feet
4000	55 "
5000	45 "
6000	40 "

- (2b) For fixed type antenna: Set "Ant. Coup." to dial reading of 30, and adjust "Ant. Load", coarse (C) for maximum shadow angle on upper sector of tuning indicator. Increase "Ant. Coup." (E) for maximum shadow angle. Recheck both antenna loading and antenna coupling to obtain widest shadow angle on indicator.

In event that there are two loading points indicated when adjusting "Ant. Load." (C), select the point of maximum dial reading which still provides use of the fine adjustment (D). Proper setting of "Ant. Load." is indicated by greater antenna current with an increase of antenna coupling from its original setting (dial reading, 30).

Upon loading the transmitter, normal increase in PA current, as indicated by the widening shadow angle on the lower sector of the tuning indicator, should be apparent. No retuning of the PA is necessary.

When the antenna circuit is properly tuned, any change in the PA tuning will result in a decrease of antenna current.

Modulation is indicated by variation in shadow angles of both sectors of the tuning indicator. Modulation of 100% is indicated by the top sector of the tuning indicator when the shadow just reaches minimum width (closes).

Control positions for the above adjustments should be apparent from the front photograph of the AVT-112 transmitter unit.

(c) Complete Equipment for Aircraft Installation:

For a complete radio installation, the following described components are necessary with interconnections as shown in Fig. 3:

(1) Radio Transmitter, AVT-112A (described above).

(2) Power Supply Unit:

In addition to the aircraft battery a separate power unit is required to supply the required plate voltages for the transmitter and receiver. The original power unit associated with the AVT-112 is the AVA-126. It is of the vibrator type and capable of supply 320 volts at 110 ma. as required by the AVT-112. This unit is 7-1/16" x 7" x 7-5/16" and weighs 10-1/4 pounds. Further data with the schematic diagram is shown in Fig. 2.

Other types of power supply units utilize the surplus dynamotors which provide the required power when operated from the necessary battery source. One such unit used very satisfactorily is the BD-87 12-volt dynamotor.

(3) Radio Receiver:

The receiver AVR-20, originally used with the AVT-112 and associated equipment is not readily usable for civilian aircraft due to its frequency range (2300 to 6700 kc.). Even though this receiver can be modified, it is a major undertaking and not considered advisable.

Another surplus aircraft type receiver that will satisfy the need is the BC-1206. It can be used very satisfactorily with only minor modifications.

The BC-1206 receiver covers 200 to 400 kc. and was designed to operate from 28 volts DC, which in addition to the filament requirements was also the plate supply.

Modification for 12-volt operation requires reconnecting the filament circuit as shown in Fig. 4 and substituting 6K6's for the original 25L6's. By utilizing approximately 90 volts from the dynamotor (through a dropping resistor) this receiver offers sufficient audio volume for speaker operation. Speaker operation requires an additional matching transformer from the headphone output to voice coil, or the direct substitution of a plate to voice coil transformer for the existing one designed for headphone use only.

It should be noted here that any commercial type of receiver may be used in conjunction with the AVT-112 providing it operates from the same battery-voltage source.

(4) Aircraft Battery:

The basic power source for aircraft radio equipment is generally a 12-volt wet-cell storage battery with a rating approximating 50 ampere-hours. Sometimes 24 volt batteries are used. The battery normally supplies the filament requirements for both the transmitter and receiver in addition to the associated relays. The greatest battery load is the plate voltage power unit.

(5) Aircraft Generator:

In order to maintain the charge of the small aircraft type battery, the generator is necessary equipment for a satisfactory radio installation. Aircraft not adaptable for engine-driven generators generally employ the wind-driven type.

(6) Aircraft Antenna:

Any conventional type of aircraft antenna, such as the types described above, may be used with the AVT-112 and its associated receiver.

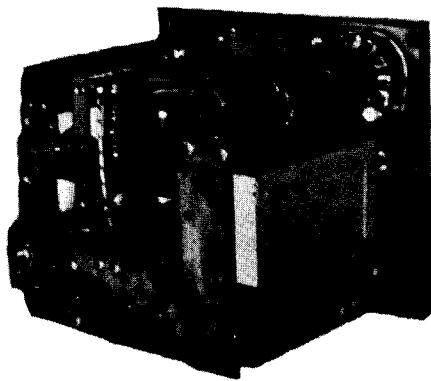

AVT-112A TRANSMITTER

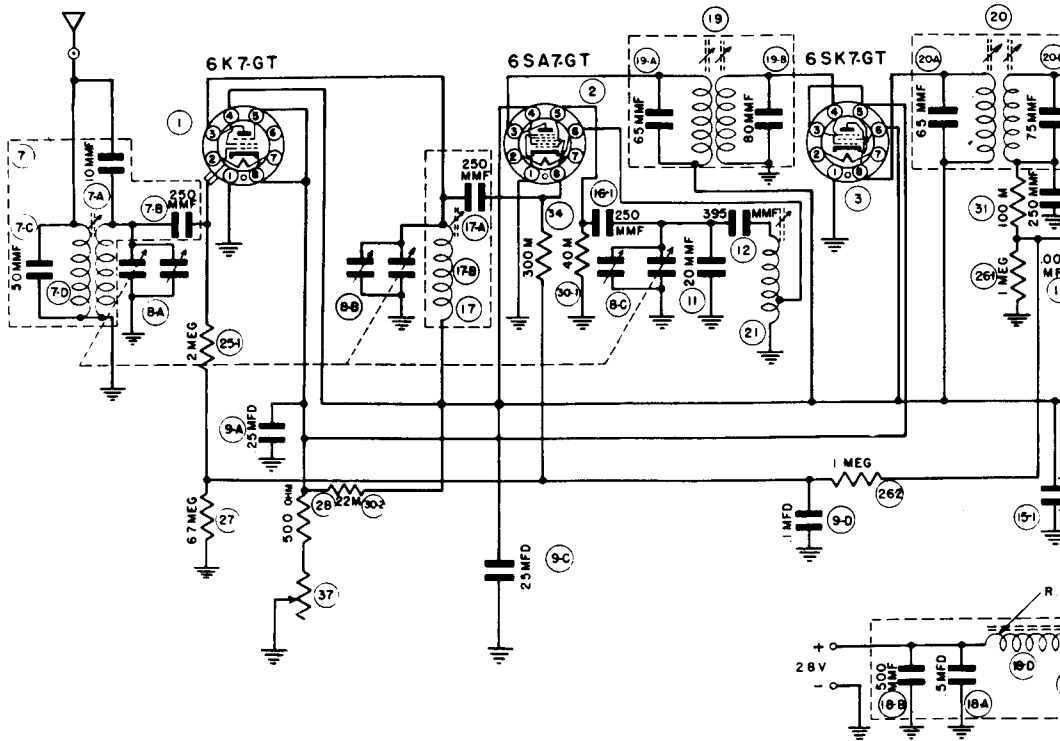

fig 4

SCHMATIC WIRING DIAGRAM
BEACON RECEIVER BC-1206-A

Tube Compliment & Functions:

- 6K7 - RF Amplifier
- 6SA7 - 1st Det. & Osc.
- 6SK7 - IF Amplifier
- 6SQ7 - 2nd Det. & 1st Audio
- 2 ea 25L6 - Audio Output

Frequency Range: 200 to 400 Kc
IF Frequency: 142.5 Kc

Receiver Sensitivity: Approx. 5
microvolts for 10 mw power
output with 4:1 signal/noise
power ratio.

Output Impedance: 300 ohms and
4000 ohms (switched internal)
Power Output: 150 mw (approx.)
Volume Control: RF gain control
Power Requirements: 28 volts dc
at 1.0 Amps.
Overall Dimensions: 4-7/16" x
4-1/2" x 7-9/32"
Weight: 3 lbs & 12 oz.

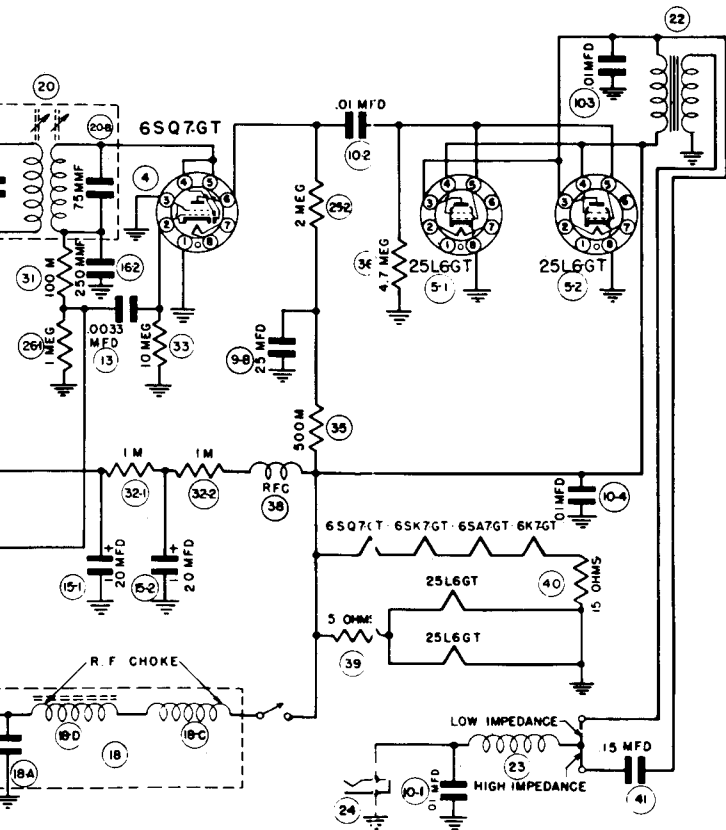

30-1	RESISTOR 40M Ω	63862
41	COND. 15 MFD	615779
40	RESISTOR 15 Ω	617299
39	RESISTOR 5 Ω	617287
38	R. F. CHOKE	615055
37	VOLUME CONT.	617807
36	RESISTOR 4.7MEG	615085
35	RESISTOR 500M Ω	615914
34	RESISTOR 300M Ω	615913
33	RESISTOR 10 MEG	615087
32-1-2	RESISTOR 1M Ω	615083
31	RESISTOR 100M Ω	615081
30-2	RESISTOR 22 M Ω	615080
28	RESISTOR 500 Ω	617365
27	RESISTOR 6.7MEG	615086
26-1-2	RESISTOR 1 MEG	615082
25-1-2	RESISTOR 2 MEG	615084
24	PHONE JACK	615011
23	R. F. CHOKE	615127
22	OUTPUT TRANS.	615118
E1	OSC. COIL ASSY.	615052
20-B	COND. 75MMF	617182
20-A	COND. 65MMF	615934
20	I. F. OUTPUT ASSY.	615009
19-B	COND. 80MMF	617183
19-A	COND. 65MMF	615934
18	I. F. INPUT ASSY.	615008
18-C	R. F. CHOKE	617167
18-B	COND. SPECIAL	615087
18-A	COND. 5 MFD	615094
18	MOTOR NOISE FILT.	615120
17-B	R. F. COIL	615053
17-A	COND. 250MMF	61286
17	R. F. COIL ASSY.	615115
16-1-2	COND. 250MMF	61286
15-1-2	COND. 20 MFD	617176
18-D	R. F. CHOKE	615091
13	COND. 0.033MFD	67313
12	COND. 395MMF	615108
11	COND. 20MMF	615108
10-123-4	COND. 0.1 MFD	617151
9-D	COND. 1 MFD	
9-A-B-C	COND. 25MFD	
9	CONDENSER ASSY.	616035
8-A-B-C	CONDENSER GANG	615912
7-D	ANTENNA COIL	615054
7-C	COND. 50MMF	61760
7-B	COND. 250MMF	61286
7-A	COND. 10MMF	615107
7	ANTENNA COIL ASSY.	615060
5-1-2	TUBE 25L6GT	64090
4	TUBE 6SQ7GT	617422
3	TUBE 6SK7GT	617419
2	TUBE 6SA7GT	617420
1	TUBE 6K7GT	617421
ITEM	NAME	NO

AM
-A

and
(external
box.)
control
points dc

x

MODIFIED CIRCUIT FOR 12 VOLT OPERATION

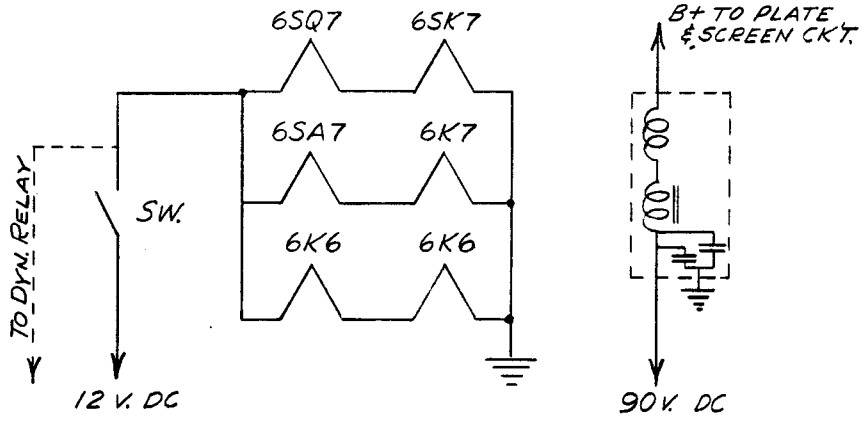

A 9-WATT UTILITY AMPLIFIER FROM THE AM-26/AIC INTERPHONE AMPLIFIER

The inexpensive, compact, AM-26/AIC Interphone Amplifier which originally served as an inter-communication unit in the larger aircraft, can be converted into a satisfactory audio amplifier. This conversion, which can be made at a very reasonable cost, results in a 9-watt amplifier with sufficient gain to operate from the average crystal phono pick-up. The amplifier is capable of driving a 10 or 12 inch PM speaker.

The AM-26 is physically 9-1/2" long x 5-1/4" wide x 5" high. In its existing form, this amplifier is of low gain with the typical 300-ohm input impedance and 30/300 ohm output impedance. It is designed to operate from 28 volts, DC, at approximately 1.25 amperes with the DM-32 dynamotor (component part) supplying the high voltage (250 volts DC).

The tube complement consists of the following with their respective functions:

- (1) 12J5 Voltage Amplifier
- (1) 12J5 Phase Inverter
- (2) 12A6's Push-Pull Power Amplifiers (output)

Before modification of the amplifier circuit, the following parts, which are not used in the converted circuit, should be removed:

Input transformer 22
Output transformer 23
Connection Plug 28
Dynamotor Plug 27 (dynamotor not used)
Gain Switch 25 and associated circuit
Hash Filter Chokes 26-1 and 26-2
Hash Filter Condensers 19-1, 19-2, and 14
Resistors 1, 2, and 3
Switch 24
Condenser 15

Conversion Procedure:

In order to use the existing tubes, the heaters are rewired in parallel. This requires a few changes in the existing circuit and the use of both transformer low-voltage windings (5.0 and 6.3 v.) connected in series as shown in Fig. 2. Polarity must be observed in order to obtain additive voltage of 11.5 volts. It should be noted that the rectifier, 6X5, operates from the 6.3-volt section of the series windings with the junction of the two windings grounded to the chassis. The heater circuit leads should be twisted where possible in order to minimize hum pick-up.

After the previously mentioned components have been removed, the power supply is constructed as shown in Fig. 2. The rectifier, 6X5, socket is mounted in the former C-14 position while the power transformer and filter choke are mounted in the space formerly occupied by the dynamotor, DM-32.

The second section of the filter utilizes the existing electrolytic filter condensers, 18-1 and 18-2. These are purposely used in the second section due to their lower voltage rating (10 mfd. at 350 volts each).

In order to give the amplifier higher gain, a 12SQ7 is used in place of the voltage amplifier stage, 12J5 (20-1). This necessitates the new associated circuit as shown in Fig. 2. The volume control is located in the grid of the 12SQ7 and replaces the former input transformer.

With slight modification, the phase inverter is changed to the self-balancing

type utilizing the existing resistors, (47K) 9-1 and 9-2, in the cathode and plate circuits respectively. It should be noted that these resistors and their associated coupling condensers, 16-1 and 16-2, are left intact with the only changes being those pertaining to resistor 9-1 which is connected into the cathode circuit of the 12J5 (20-2).

In the grid circuit of the 12A6's, R-11 is removed and the grid resistors 10-1 and 10-2 are connected to ground.

It is most desirable to use a universal type output transformer to match the speaker voice coil to the plates of the 12A6's. Other types of output transformers may be used as long as the load impedance reflected to the 12A6's is approximately 12,000 ohms.

The tone control, as shown in the plate circuit of the 12SQ7, is optional. It merely lends more flexibility to the amplifier for average listening use. Other types of tone-control circuits may be substituted as desired. If the frequency response is poor in the high frequency range, the values of condensers 17-1 and 17-2 should be reduced as desired. These values may be approximately .005 or .01 mfd.

It should be noted that the original feedback circuit, condenser 16-3 and R-6 and R-7, is not used in the new circuit. R-6 is used as the cathode-bias resistor in the phase inverter circuit. The other components may be left or removed as desired.

The AC circuit is connected on the original terminal board which contained the former resistors 1, 2, and 3. This board provides neat and convenient tie points for the leads concerned. The AC power switch is incorporated on the volume control.

It will be found that the completed amplifier is a neat and compact unit which has many applications. It may be used as a phono amplifier, inter-com amplifier, modulator for low-power transmitters, and so forth. This unit is capable of delivering 9 watts at less than 5 per cent distortion; distortion of course becomes negligible at the normal listening level of approximately one watt.

An alternative circuit is shown in Fig. 3. It will be noted that this amplifier utilizes the floating paraphase circuit. Also, dual tone controls are used for added flexibility in controlling the frequency response.

AM-26/AIC INTERPHONE AMPLIFIER (ORIGINAL SCHEMATIC)

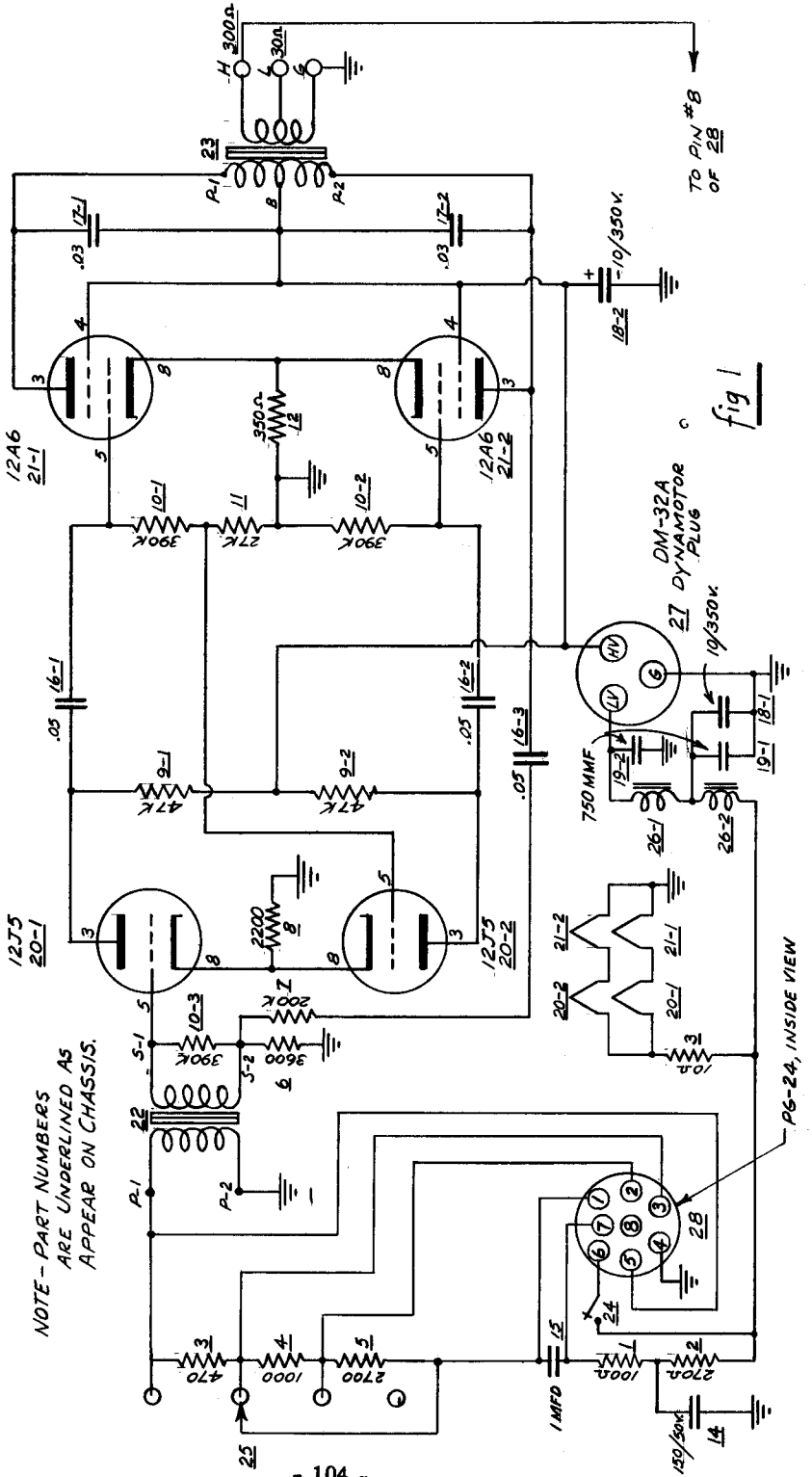

CONVERTED AM-26 AMPLIFIER

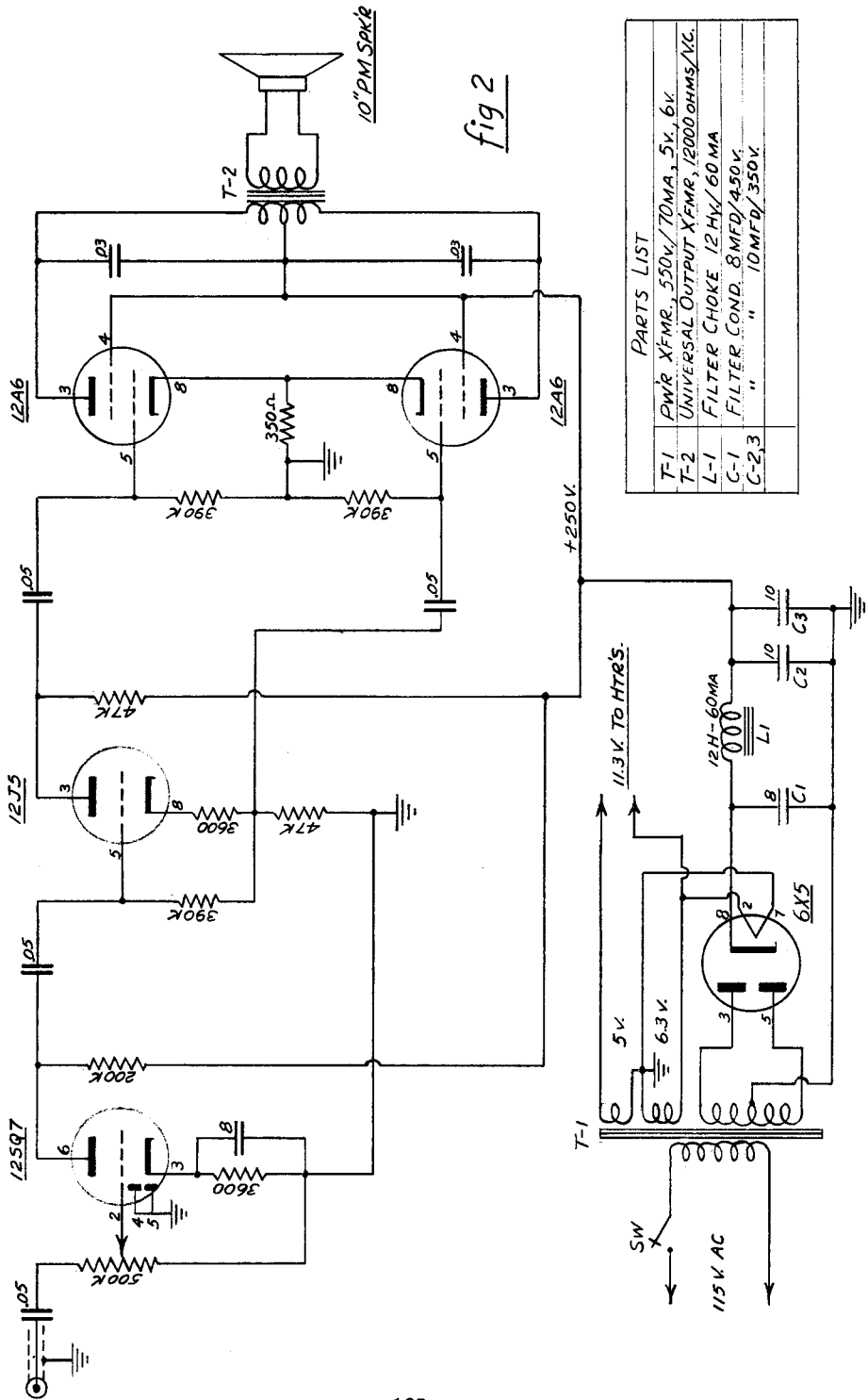
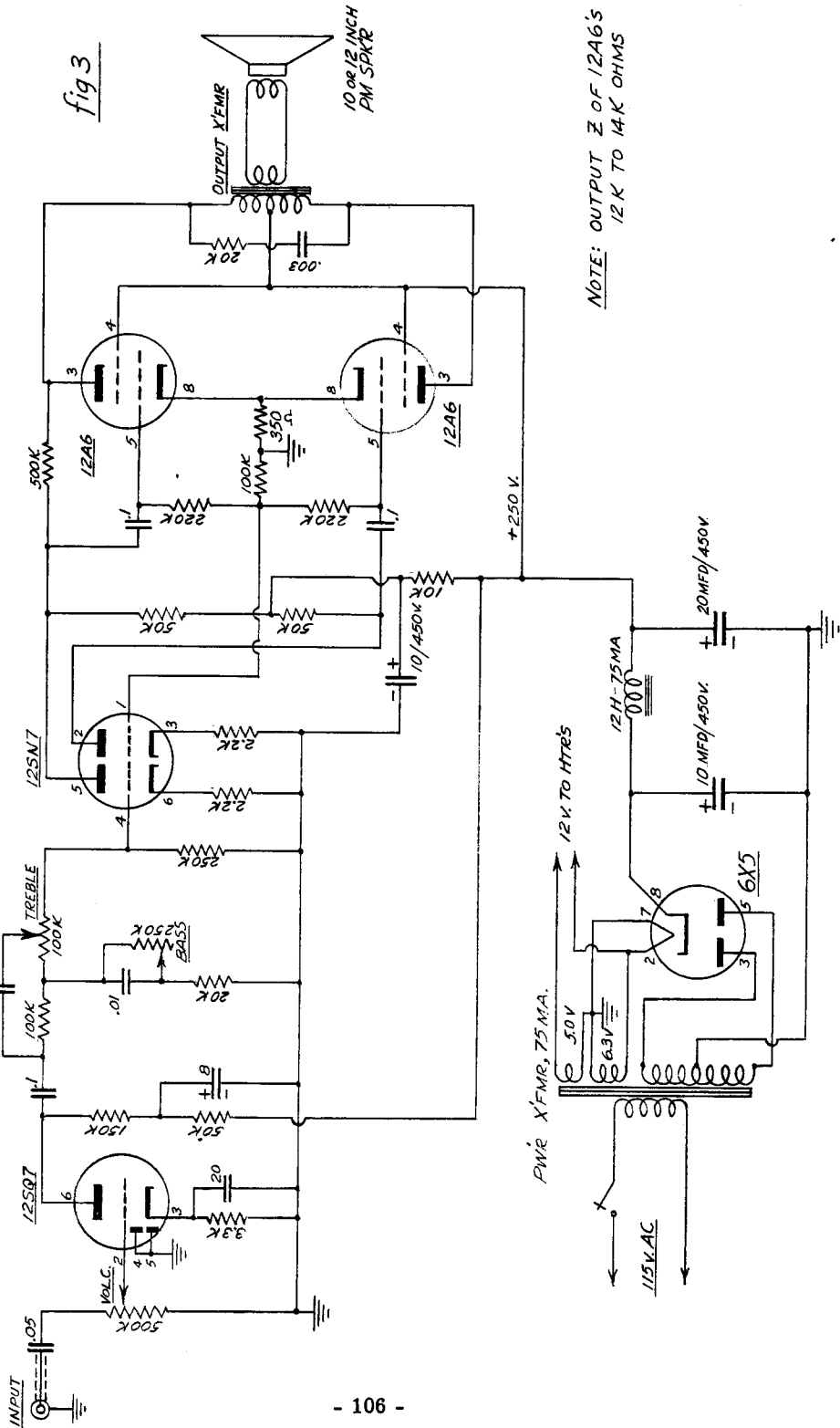

fig 2

PARTS LIST

T-1	PWR. XFMR., 550V./70MA., 5V., 6V.
T-2	UNIVERSAL OUTPUT XFMR., 12000 OHMS/V.C.
L-1	FILTER CHOKE, 12 H./60 MA.
C-1	FILTER COND., 8 MFD./450V.
C-2,3	" " 10 MFD./350V.

A HIGH QUALITY RADIO/PHONO AMPLIFIER FROM THE AM-26



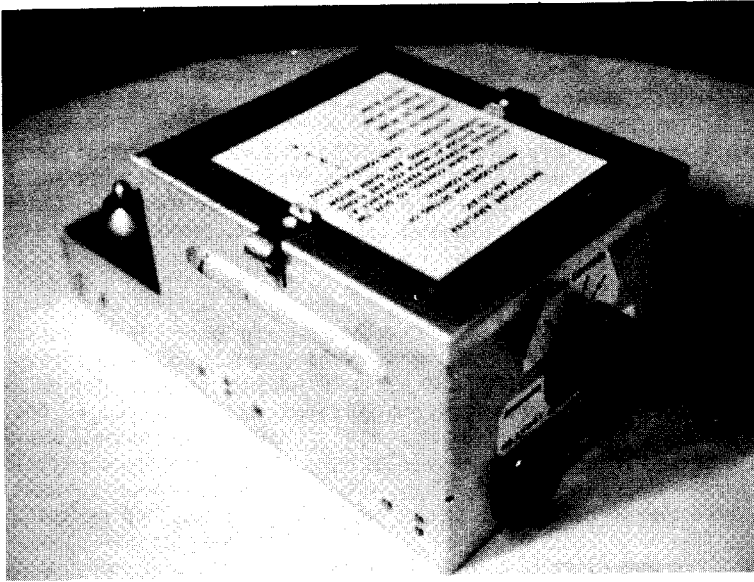
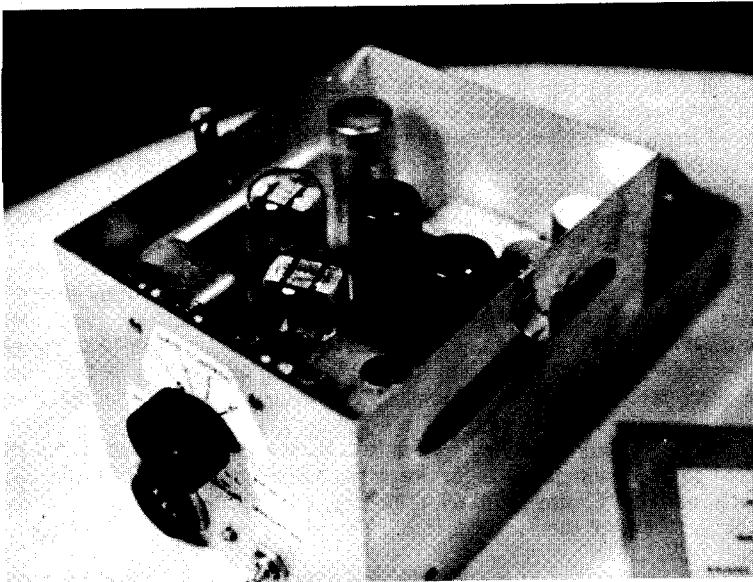

fig 4



AM-26/AIC AMPLIFIER (ORIGINAL)

THE MODEL LM FREQUENCY METER

One very satisfactory item of test equipment that has appeared on the surplus market is the Navy Model LM Frequency Meter. The unit covers the frequency range shown in Fig. 1 for different models.

The LM Frequency Meter is very similar in design and operation to the Army BC-221.* Similarly, it has many successive models designated by a number suffix (LM-1, LM-2, etc.). The general characteristics of all models are identical. Later models have minor improvements and changes as indicated in the comparison chart, Fig. 1.

(a) Description

The primary component of the LM Frequency Indicating Equipment is the heterodyne frequency meter (C-74028, Navy component designation). Physical dimensions of this unit are approximately 8-1/2" x 8" x 8-1/2" with its weight being about 11-1/2 pounds. Other components necessary for operation of the heterodyne frequency meter are the calibration book, low impedance headset (600 ohms), and a power supply capable of supplying the required voltages as listed in the comparison chart. Complete equipment also includes the frequency meter shock-mounting base, carrying case, shielded power cable with plugs, instruction books, and operating spare parts.

Essentially, the electrical circuits of the LM heterodyne frequency meter consist of a crystal calibration oscillator (1000 kc.), a manually-tuned VFO, a high-gain detector, and an audio-frequency amplifier. By manually switching the circuit of the audio frequency amplifier, it functions as an audio oscillator which modulates the VFO.

The 1000-kc. crystal oscillator is used as a reference standard for calibrating the VFO at a number of points over the tuning range. High stability of the crystal oscillator is maintained due to special design of its components. The crystal unit is hermetically sealed in an evacuated metal envelope, resembling a small metal vacuum tube with an octal base. Due to this type of construction, the crystal unit is relatively unaffected by physical variations such as barometric pressure, humidity, vibration, shock or mounting position. The temperature coefficient of the crystal unit is less than 0.0001 per cent variation in frequency per degree Centigrade over an ambient temperature range of 80 degrees. Inherent design of the crystal oscillator circuit provides an output rich in harmonics thus providing a number of useful check points over the entire tuning range of the VFO.

The VFO is an electron coupled, heterodyne type of oscillator, capable of being calibrated by the "zero-beat" method at various predetermined points over the two manually-tuned ranges. Fundamental ranges of the VFO are 125 to 250 kc., and 2000 to 4000 kc. Employing the calibrated 1st, 2nd, 4th and 8th harmonics, the first range gives continuous coverage from 125 to 2000 kcs; likewise, by the use of the calibrated 1st, 2nd, 4th, and part of the 5th harmonics, continuous coverage is obtained from 2000 to 20,000 kcs. in the second range.

Tuning of the VFO is accomplished by a low-temperature-coefficient, variable condenser with a 100:1 gear reduction from the external control. This ratio requires 50 revolutions of the vernier dial for 180-degree rotation of the variable condenser. Backlash in the gear mechanism is held to less than 0.3 of 1 division on the dial units scale.

The low temperature coefficient of the VFO tuned circuit is maintained by temperature compensated components used in conjunction with the tuning condenser. The temperature coefficient of the VFO is less than 0.003 per cent of the frequency per degree Centigrade over an ambient range of 97 degrees for the entire range.

Arrangement of the detector circuit allows the mixing (comparison) of three RF sources. These are the Crystal Calibration Oscillator (electron coupled), the VFO output (control grid injection), and the incoming RF signal from the antenna terminal

* "Surplus Radio Conversion Manual," Volume I

COMPARISON BETWEEN MODELS OF THE MODEL LM SERIES

Model	Freq. Measuring Unit Type	Het. Osc. Freq. Range—Kcs.	Operating Voltage	Mechanical Design	Remarks
LM	None	195-400 2000-4000	12/14 200/260		
LM-1	None	195-400 2000-4000	External battery supply	Same as LM	
LM-2	None	195-400 2000-4000	12/14 200/260—260/475	General minor im- provements throughout	Voltage regulator circuit added
LM-3	None	195-400 2000-4000	External battery supply	Same as LM-2	
LM-4	None	195-400 2000-4000	12/14 200/260—260/475	Same as LM-2	Symbol designations reassigned
LM-4a	None	195-400 2000-4000	24/28 200/260—260/475	Same as LM-4	
LM-5	None	195-400 2000-4000	12/14 200/260—260/475	Same as LM-4	
LM-6	CRR-74023	195-400 2000-4000	Rectifier Power Unit Type CRR-20104	Same as LM-4	
LM-7	CRR-74024	195-400 2000-4000	12/14—24/28 200/260—260/475	Redesigned shockmount base and capacitor and drive assembly	
LM-8	CRR-74024	195-400 2000-4000	Rectifier Power Unit Type CRR-20104	Same as LM-7	
LM-9	CRR-74024	195-400 2000-4000	12/14—24/28 200/260—260/475	Same as LM-7	Included in Type CRR-10086 Waterproof Carrying Case
LM-10	CRR-74028	125-250 2000-4000	12/14—24/28 200/260—260/475	Minor mechanical revisions	LF Het. Osc. fund. freq. range changed
LM-11	CRR-74028	125-250 2000-4000	Rectifier Power Unit Type CRR-20104 or Rectifier Power Unit Type CRR-20104A	Same as LM-10	
LM-12	CRR-74028	125-250 2000-4000	12/14—24/28 200/260—260/475	Same as LM-10	Included in Type CRR-10086 Water- proof Carrying Case
LM-13	CRR-74028	125-250 2000-4000	Self contained batteries	Same as LM-10	Mounted in Type CRR-10111 Carrying Case with batteries
LM-14	CKB-74028	125-250 2000-4000	12/14—24/28 200/260—260/475	Same as LM-10	
LM-15	CKB-74028	125-250 2000-4000	Rectifier Power Unit Type CKB-20104A	Same as LM-10	
LM-16	CKB-74028	125-250 2000-4000	12/14—24/28 200/260—260/475	Same as LM-10	Included in Type CKB-10086 Waterproof Carrying Case
LM-17	CKB-74028	125-250 2000-4000	Self contained Batteries	Same as LM-10 less shock mount base	Mounted in Type CKB-10111 Carrying Case with batteries

fig 1

(also control grid injection). By means of switching, either the crystal oscillator signal or the incoming signal is manually selected for heterodyning with the VFO.

The detector output, after being amplified by the AF stage, is brought out through a jack on the front panel for a 600-ohm load. The audio output is intended for low-impedance headphones; however, other indicating devices can be used.

Frequency response of the audio section is intentionally peaked at 250 cps. At 100 cps and 500 cps the response drops approximately 1.5 db below the 250 cps reference.

When the heterodyne oscillator is being used to radiate an RF signal, the signal can be amplitude modulated with a 500 cps tone by manually switching the AF amplifier circuit to the "Modulation On" position. Under this condition the audio amplifier becomes an audio oscillator capable of modulating the VFO about 40 per cent.

Power requirements for the LM Frequency Meter involve filament supply and plate supply voltages. By setting the links in the filament circuit, the filaments may be operated from either 12 or 24 volts. Similarly, links are used for the selection of the plate voltage range. The settings are: low range, 200 to 260 volts; and high range, 260 to 475 volts. Plate and screen voltage for the VFO stage are regulated by means of neon glow lamps.

It should be noted that the plate circuit can be manually switched ON and OFF independently from the filament circuit. This permits warming up of the unit or keeping it in readiness without radiation from the VFO or unwanted output in the headphones.

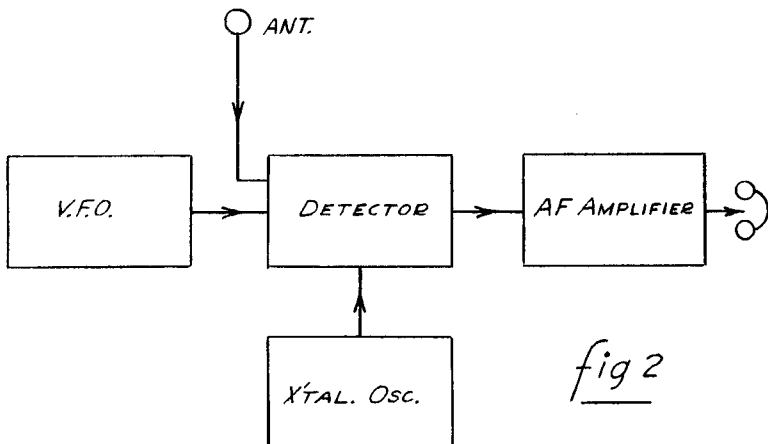

(b) Operation:

Before attempting accurate frequency measurements with the LM Frequency Meter, the heaters should be allowed a minimum 10-minute warm-up period. In order to utilize the VFO dial readings (not calibrated in frequency), the calibration book which specifically accompanies the instrument must be used. From this book the calibration point for the VFO may be determined in the range in which the frequency measurement is desired. The crystal check points for the respective ranges are indicated at the bottom of each page, printed in red.

After allowing a sufficient warm-up period, and switching on the plate voltage, the VFO is carefully calibrated to the designated check point by adjusting the "Corrector" dial for "zero-beat" as heard in the headphones. The Modulation switch must be in the "OFF" position for this adjustment.

Having calibrated the VFO, as described above, the frequency meter is ready for frequency indication. It should be noted that prolonged intervals between the VFO calibration and frequency measurement should be avoided to eliminate the possibility of frequency drift in the VFO.

In measuring the frequency of a local RF source (transmitter), it is necessary that a short antenna lead be connected to the frequency meter's antenna post. This antenna lead should be only loosely coupled to the transmitter output. Over coupling should be avoided so as not to damage the frequency meter circuits.

Adjustment of the "RF Coupling" control is made for the desired listening level in the headphones. By manually tuning the VFO, "zero-beat" is obtained with the incoming signal as heard in the audio output. The frequency is then determined from the VFO dial reading by referring to the calibration book.

It should be noted that in the reverse procedure from that described above, the transmitter may be tuned to "zero-beat" with the frequency meter, thus adjusting the transmitter to the desired frequency.

In adjusting a receiver to a desired frequency, or checking its dial calibration, the VFO of the frequency meter is used to radiate a signal from a short antenna lead. Loose coupling to the receiver concerned is generally adequate. After setting the calibrated VFO to the desired frequency, the receiver is tuned for zero-beat as heard at its output. A modulated signal from the frequency meter is required for receivers not equipped with a beat-frequency oscillator. Receiver alignment can be accomplished by using the frequency meter's modulated VFO as a signal generator in the conventional manner.

From the above, it is also apparent that frequency measurement of a distant RF source may be made by "zero-beating" it in a receiver with the radiated VFO signal.

(c) Accuracy of Measurements:

In the calibration book, the low frequency fundamental range is logged at each 0.1-kc. point between 125 and 250 kc. Similarly, the high frequency fundamental range is calibrated at each 1-kc. interval. By use of the interpolation table in the calibration book, frequencies that fall between the logged frequencies may be determined.

Accuracy of frequency measurement in reference to the crystal frequency is better than 0.02 per cent for any frequency within the 125-2000 kc. range, and better than 0.01 per cent for any frequency in the 2000-20,000 kc. range.

A desirable feature included in the exceptionally good design of this unit is the non-locking-in characteristic between the heterodyne oscillator and the RF source to which it may be coupled. Even though the headphones become rapidly inefficient in reproducing beat tones below 100 cps, characteristic audible "rushes", which coincide with the beat frequency, are recognizable well below the low frequency limit of audibility.

In some models of the LM Frequency Meter, the crystal oscillator is provided with a trimmer capacitor across the crystal. By this adjustment, the crystal frequency may be calibrated against WWV.

(d) Addition of An AC Power Supply:

The nominal power requirements for the Model LM series Frequency Meter are, 12 volts at 0.6 amperes (filament supply) and 250 volts at 20 ma. (plate supply). An AC power supply to satisfy these requirements is shown in Fig. 4. It should be noted that for portable use the frequency meter may be powered with batteries without any alteration of the power circuits. Socket connections can be determined from the schematic diagram, Fig. 3.

Details for adapting the LM Frequency Meter for the added AC power supply are given in Fig. 4. If a mating plug for J-102 is not available, the plug can be removed with the necessary leads to the power unit being brought out through the hole formerly occupied by J-102.

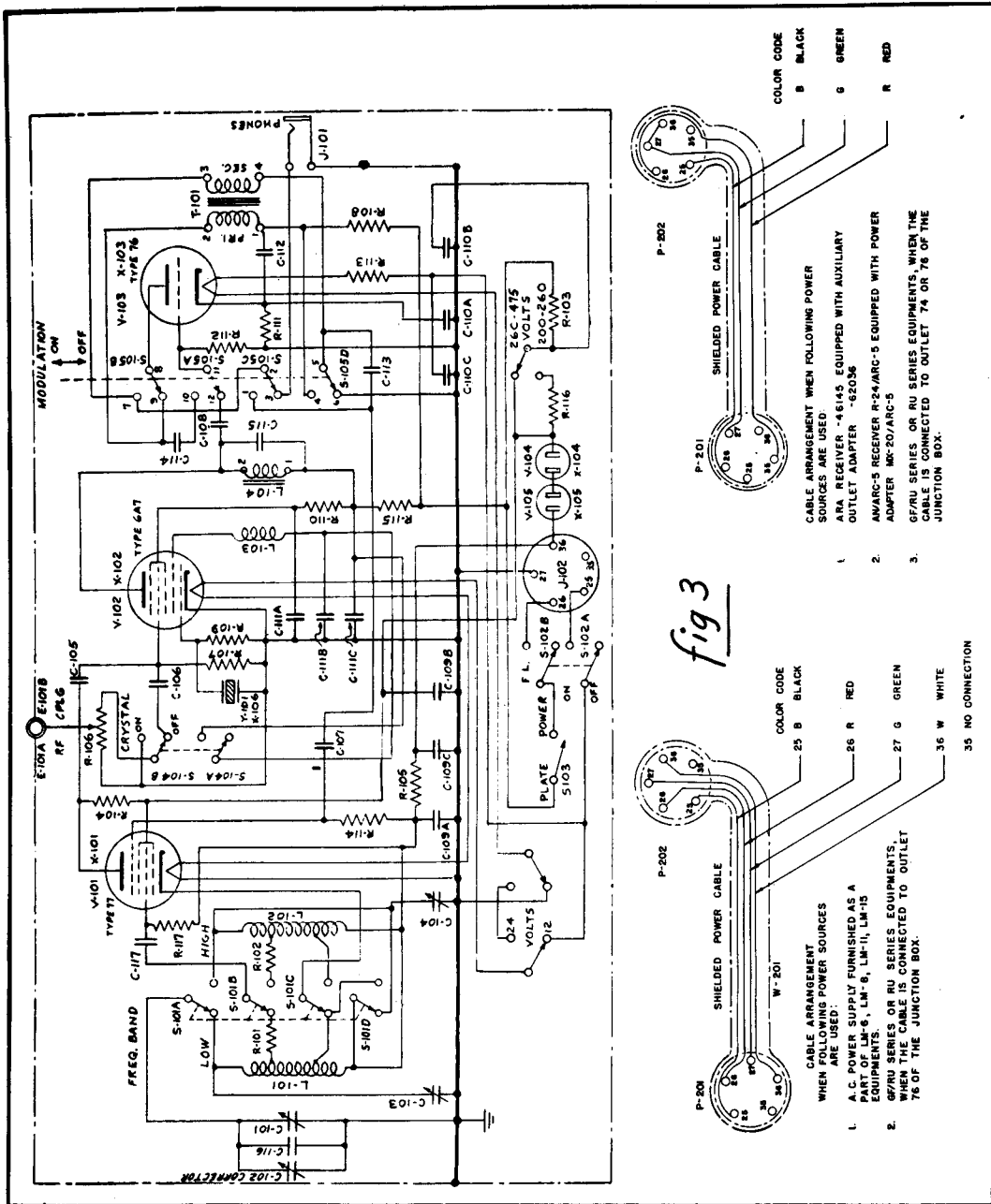

fig 3

COLOR CODE
 B BLACK
 G GREEN
 R RED

CABLE ARRANGEMENT WHEN FOLLOWING POWER SOURCES ARE USED

1. ARA RECEIVER -46145 EQUIPPED WITH AUXILIARY OUTLET ADAPTER -62036
2. AN/ARC-5 RECEIVER R-24/ARC-5 EQUIPPED WITH POWER ADAPTER MK-20/ARC-5
3. 6F7RU SERIES OR 6RU SERIES EQUIPMENTS WHEN THE CABLE IS CONNECTED TO OUTLET 74 OR 76 OF THE JUNCTION BOX.

COLOR CODE
 25 B BLACK
 26 R RED
 27 G GREEN
 35 W WHITE

CABLE ARRANGEMENT WHEN FOLLOWING POWER SOURCES ARE USED

1. A.C. POWER SUPPLY FURNISHED AS A PART OF LM-5, LM-6, LM-11, LM-15
2. 6F7RU SERIES OR 6RU SERIES EQUIPMENTS. WHEN THE CABLE IS CONNECTED TO OUTLET 76 OF THE JUNCTION BOX.

AC POWER SUPPLY FOR THE LM FREQUENCY METER

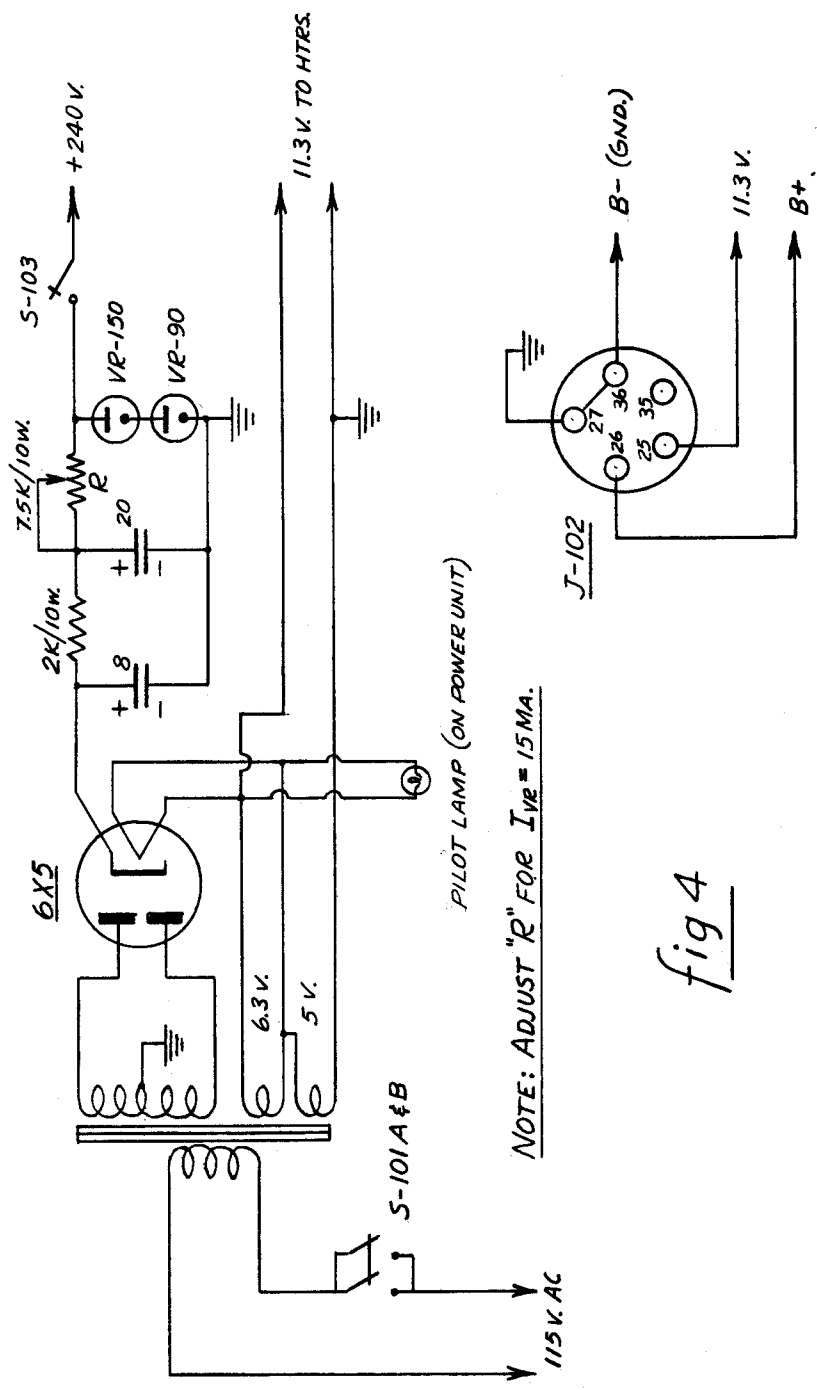
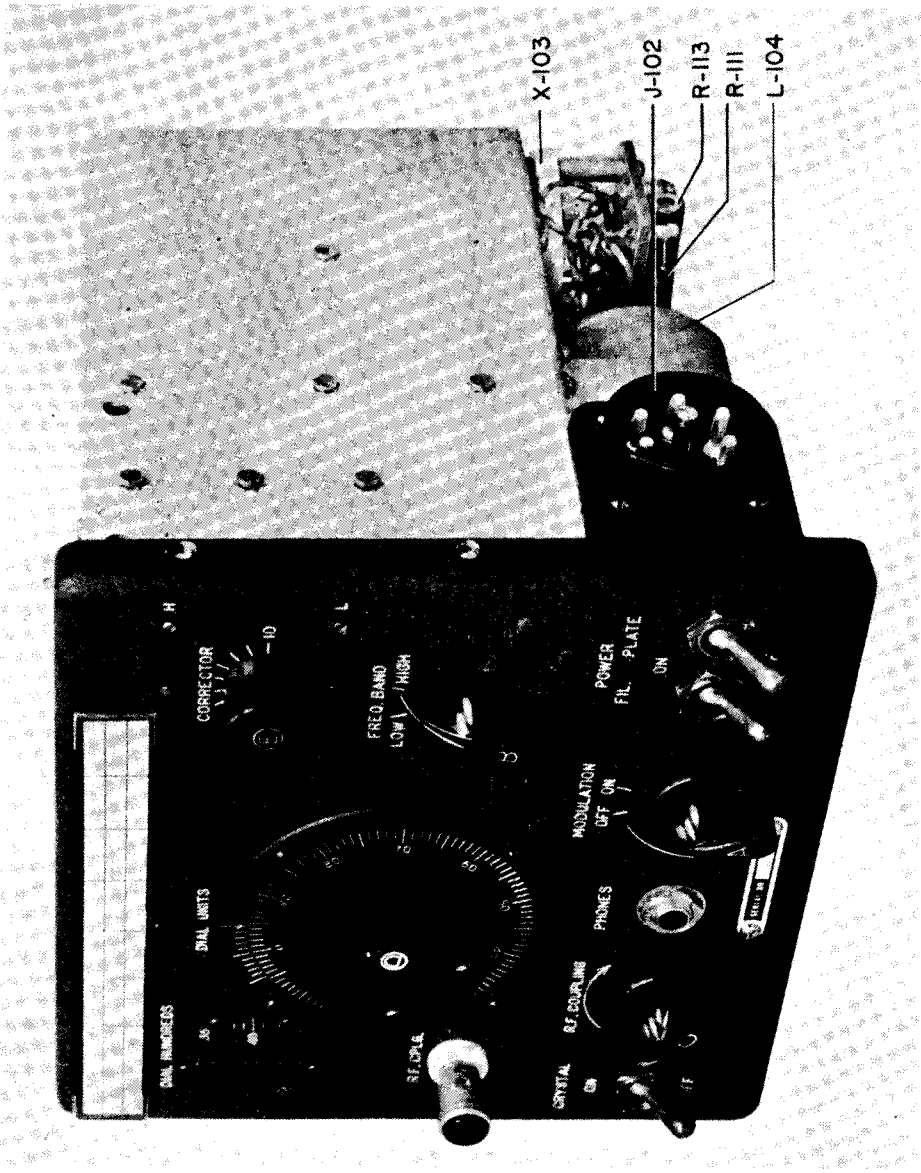

fig 4



LM FREQUENCY METER (Cover Removed) Fig. 5

SURPLUS BEAM ROTATING MECHANISMS

The surplus market has brought several economical means for rotating beam antennas within the reach of the average amateur. This section covers the conversion necessary to adapt several surplus mechanisms for this purpose.

Signal Corps Antenna Reel:

One of the less expensive devices to appear is the Signal Corps Antenna Reel RL-42B. It consists of a 24-volt reversible motor (8500 RPM) attached to a reduction gear box which drops the speed to 120 RPM with considerable torque. It will rotate, directly, small beams, or can be used to turn a gun mount unit (described later) at a still further reduction in speed with resultant increase in torque to turn the heaviest beams. The Antenna Reel has an extra take-off gear which can be used to drive a Selsyn generator for direction indication as this shaft turns at the same speed as the main shaft.

The motor was intended to operate on 24 volts DC, but it will run on 24 volts AC. One factor exists, however, to make alteration necessary. Inside the motor casing is a clutch mechanism actuated by a 24-volt DC solenoid. This clutch chatters when operated on AC. Therefore it must be permanently locked or removed and a suitable coupling used to replace it. Two micro switches and a bathtub condenser should also be removed from the gear box. The following steps will describe these operations:

First, remove the reel, if it is snapped on to the gear box shaft, and take out the 8 flat-head screws holding the top cover plate. This allows the top plate to be removed, although it may have to be pried off. The main shaft and associated gear will come off with this cover plate. The inspection side plate should be removed also which will now give access to the gear box interior. The two micro switches may be easily removed by taking out the two large screws on the side opposite the motor, allowing a screwdriver to be inserted for removing the long retaining screws. Clip off the wires to the switches, as the only wires needed are the three from the motor itself. The bathtub condenser should be clipped out and removed. All wires to the plug should be clipped off close, as the entire length of the motor leads will be needed.

Remove the four screws holding the motor to the gear box, and then pull off the motor. Now remove the fibre ring from the motor and take out the four long screws of the motor end plate. This will allow the clutch mechanism to be exposed. The problem from here on is to eliminate the clutch action. This may be accomplished by two methods: the first is to remove both clutch plates and substitute a metal or flexible coupling; the second, merely connect the two plates together permanently.

If the substitution of a coupling is desired, proceed as follows: Push in on the small gear, insert a hacksaw blade, and cut off that clutch plate. The other plate can be pried off its shaft after removing the retaining allen screw. (Be very careful not to bend the shafts during this process.)

The solenoid can now be removed by clipping the leads and sliding it off the shaft with its associated fibre washers and parts. Should a coupling be used to connect the two shafts, it will be necessary to drill out or shim the coupling to take the shaft ends. Added length of the shaft on the gear end may be obtained by removing the spring-type washers under the gear.

The alternate method, joining the clutch plates permanently, can be accomplished by drilling two or more holes through the plates and tapping the set of holes in the plate on the motor side. It will be necessary to drill completely through the heavy end plate and through the one clutch plate unless the small gear can be removed and the plate pulled off to work on it. Short 6-32 screws can now be screwed through the plate on the motor side, allowing about 1/16 inch to extend out and fit into the holes of the plate on the gear side, acting as pins.

Before assembling the unit, it will be necessary to replace the present electrical connection plug with another which can be fitted with a mating section.

The unit may now be assembled and connected for operation. One of the motor leads (usually black) is common and either one of the other leads will give rotation when connected to 24 volts AC. One lead gives CW rotation, the other CCW rotation. A transformer will be required to step down the 115 volts AC to approximately 24 volts required.

If a light beam is used, it may be fitted on to the main shaft of the gear box by various means, depending of course upon the beam support used. If a heavier beam is used, it will be necessary to obtain a surplus gun-mount mechanism to increase the torque and correspondingly lower the speed of rotation. This unit is described in the following section.

See photos at end of this article for the appearance of the unit. Fig. 1 is a typical installation.

K7 Gun Mount:

Another outstanding surplus item which can be used as a beam rotating device is the K7 Gun Mount which was originally used by the Armed Services for rotating machine guns. This gun consists of a fairly large gear box about the size of a gallon paint can, on top of which is a flat rotating mounting plate. Originally, the unit was used to rotate a gun in both the horizontal and vertical planes with two flexible shafts used for controls. Only the horizontal rotation flexible shaft is practicable for beam rotation. It can be made as long as desirable for remote control.

The unit has an approximate gear ratio of 40:1, that is, the mounting plate will complete one revolution for 40 revolutions of the flexible shaft.

The flexible shaft can be turned by hand or by some motor drive mechanism such as the Antenna Reel RL-42B, described in the preceding paragraphs. The antenna reel has sufficient power to turn the gun mount when coupled through a flexible shaft even when a very heavy beam is used. In the installation described, the gun mount rests on an outside platform with a 4" x 4" pole 20-feet high bolted to the gun mount plate. A 20-foot flexible shaft extends into the shack and is driven by the Signal Corps antenna reel, which is wall mounted.

Lubrication is very important in the use of the K7 gun mount. Before placing it in operation, the mounting plate and gear box cover should be removed and the top gear compartment filled with transmission grease (about SAE-90). This will prevent freezing of the gears and rust formation. All other rotating parts should be well lubricated if the unit is not protected from the weather.

Selsyn Generators Type 2J1F3:

There are many types of Selsyn units available on the surplus market, all operating on the same principle. But most of them are quite expensive. The type 2J1F3 is one of the smaller Selsyns and it is economical for use as a remote indicator. These units are about 4-1/2 inches long and approximately 2-1/4 inches in diameter. They will operate from 24 volts AC and thus work very well in conjunction with the Antenna Reel described previously. A pair of the units is necessary, of course, for the indication system. One is geared to the beam itself and the other is at the operating position with a compass card attached for indicating 0 to 360 degrees. The only problem involved in the use of the Selsyns is that of obtaining the correct gear ratio at the indicator end, so that the beam and indicator are rotating at the same speed. This is a mechanical problem and will vary with the type of beam rotators used; however, some of the surplus dial mechanisms as used in tuning units and so forth have gear ratios which will work out nicely with the K7 gun mount and Signal Corps antenna reel. The diagram in Fig. 2 is typical of all Selsyn motor circuits.

Rotator Motor Type G303AY2:

Another popular and extremely practical beam rotating device is the Rotator type G303AY2. This motor was originally designed and used on 400 cycles. However, by the simple addition of a phasing condenser, (12-20 mfd., oil or paper), the motor will operate directly on 110 volts AC, 60 cycles and provide an economical and husky beam rotator.

Since the motor is of the induction type, no noise is created by brushes or moving mechanical parts. It is of the reversible type, requiring only 3 wires for operation. Its weight is 3 lbs. and it is approximately 5" x 5" x 4" in size. It revolves at a speed of 3/4 RPM.

The motor will drive satisfactorily most 10 and 20 meter beams, providing they are of light construction. For the heavier beams a bearing surface is recommended. Two-meter, six-meter, television, and FM beams can easily be driven directly from the motor shaft.

To place the motor in operation, remove the elastic stop nut and lever arm, remove the three screws and top cover plate, being careful to save the gasket and slip off the plate containing the two wiper arms (this plate merely served as a stop mechanism and will not be required). In order to remove the wiper arm plate, the motor will probably have to be connected to 110 volts as per Fig. 3 and allowed to rotate until the wiper arms are in the center position where they can be slipped off. The gear of the wiper arm assembly can be used on the end of a length of thin-walled tubing as a beam support if desired. This is accomplished by using a hacksaw as per Fig. 4 and cutting out the gear, being careful not to damage the gear teeth. The gear can now be pressed into a piece of tubing or other support.

Do not remove the four screws held by safety wires on the end of the motor opposite the rotating gears, as the motor and gears are sealed in oil. A drain plug is provided on the side of the motor case for draining and filling as required.

Connect the motor through a condenser and switch as per Fig. 3 and the unit is ready for operation. It can easily be mounted by means of the four tapped holes on the side.

The photos at the end of this article will give a general idea of the appearance.

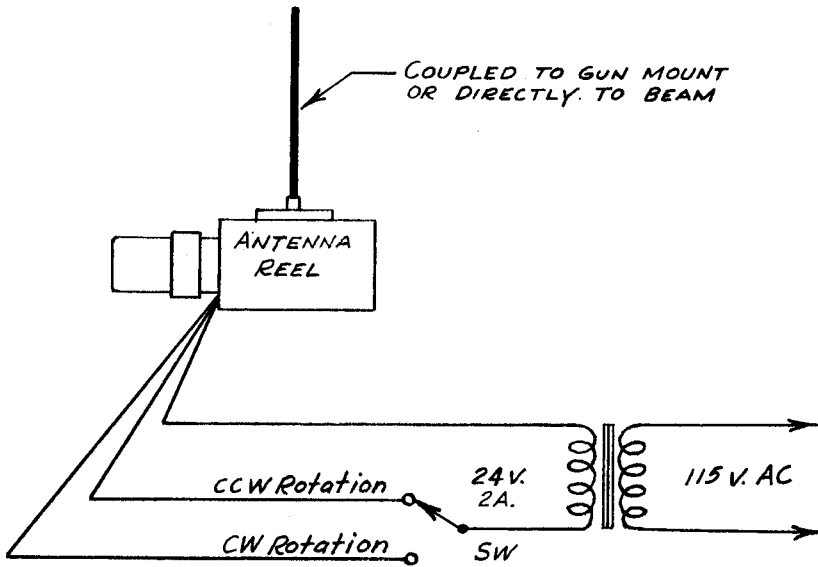

fig 1

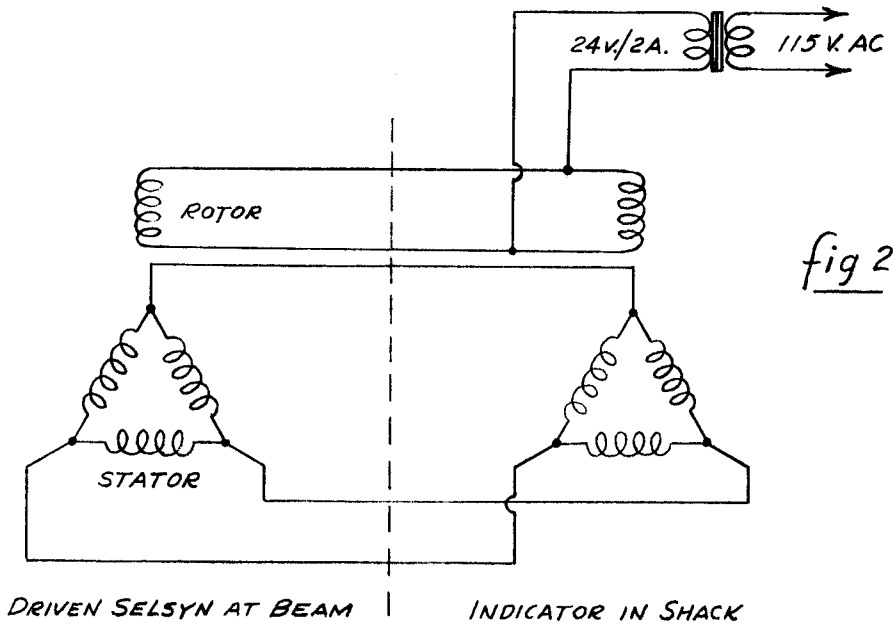

fig 2

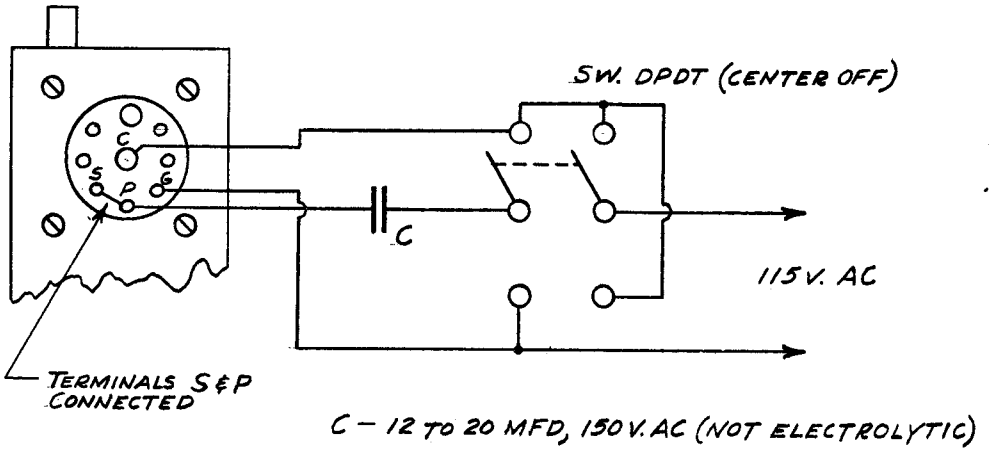

fig 3

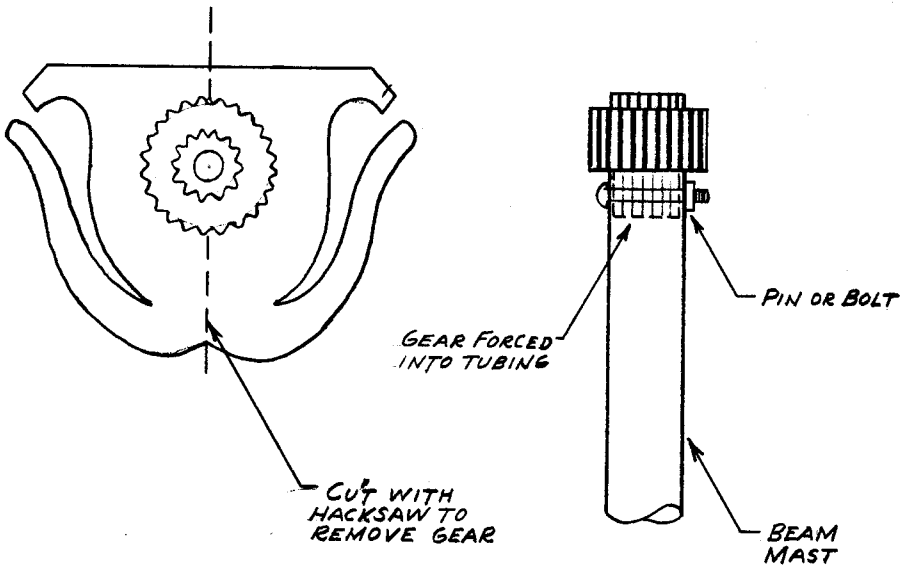
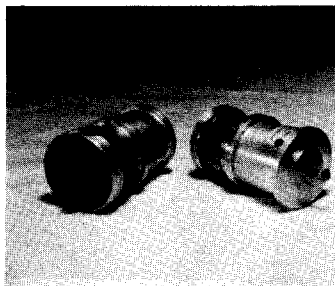
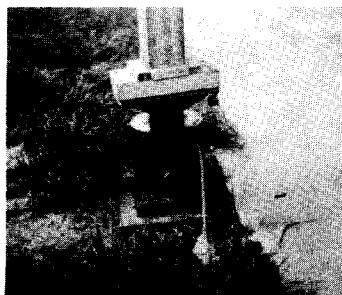

fig 4

SURPLUS BEAM ROTATING MECHANISMS



SELSYN GENERATORS
TYPE 2J1F3



K7 GUN MOUNT

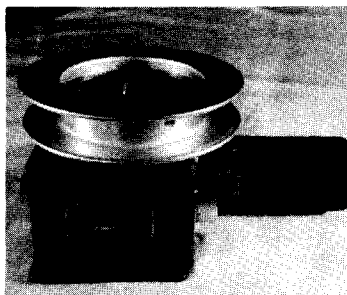

SIGNAL CORPS
ANTENNA REEL

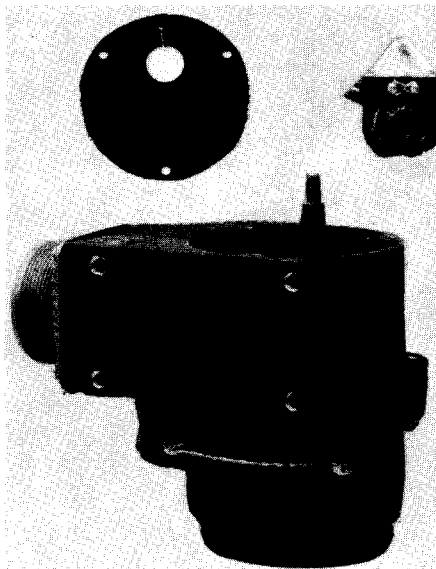

BEAM ROTATOR (G303AY2)

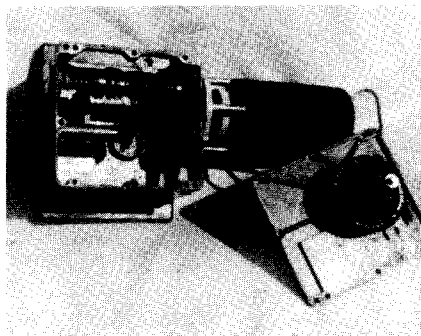

SIGNAL CORPS
ANTENNA REEL

fig 5

UNIT:	POWER REQUIREMENTS:
BC-191	12 Volts DC (Dyn)
BC-221	Batteries (6 Volts and 135 Volts)
BC-223	12 - 14 Volts DC (Dyn)
BC-224	14 Volts DC (Dyn)
BC-312	12 - 14 Volts DC at 6 amps (Dyn)
BC-342	110 Volts AC, 60 cycles at 65 watts
BC-344	110 Volts AC, 60 cycles at 65 watts
BC-348	28 Volts DC (Dyn)
BC-375	24/28 Volts DC at 600/840 watts Plates --28 Volts at 20 amps (Dyn) Filaments -- 24 Volts at 8 amps (Batts)
BC-403	115 Volts AC, 60 cycles
BC-404	115 Volts AC, 60 cycles
BC-412	115 Volts AC, 60 cycles
BC-433	14 or 28 Volts DC + 115 Volts 400 cycles
BC-453	28 Volts at 1.1 amps DC (Dyn)
BC-454	28 Volts at 1.1 amps DC (Dyn)
BC-455	28 Volts at 1.1 amps DC (Dyn)
BC-457	28 Volts at 3.7 amps DC (Dyn)
BC-458	28 Volts at 3.7 amps DC (Dyn)
BC-459	28 Volts at 3.7 amps DC (Dyn)
BC-603	12 Volts DC/ 4 amps (Dyn) or 24 Volts DC/ 2 amps (Dyn)
BC-604	12 Volts DC/ 20 amps (Dyn) or 24 Volts DC/ 12 amps (Dyn)
BC-645	400 Volts DC at 135 ma/ 9 Volts AC/ 1.2 amps
BC-659	6, 12, or 24 Volts DC
BC-683	12 Volts DC/ 4 amps (Dyn) or 24 Volts DC/ 2 amps (Dyn)
BC-684	12 Volts DC/ 20 amps (Dyn) or 24 Volts DC/ 12 amps (Dyn)
BC-696	28 Volts DC at 1.1 amps (Dyn)
BC-736B	115 Volts, 60 cycles AC
BC-923	12 Volts DC/ 7.2 amps (Dyn) or 24 Volts DC/ 3.85 amps (Dyn)
BC-924	12 Volts DC at 26 amps (Dyn) or 24 Volts DC at 16 amps (Dyn)
BC-929	110 Volts, 400 cycles AC
BC-946	28 Volts / 1.1 amps DC (Dyn)
BC-966A	12 Volts DC (Dyn)
BC-1023A	12 or 24 Volts DC
BC-1068A	115 Volts, 60 cycles AC
BC-1072A	115 Volts, 60 cycles AC
BC-1161A	115 Volts, 60 cycles AC
BC-1206	28 Volts, DC/ 1 amp
BN	105-125 Volts AC, 50-400 cycles
CRV 46068	115 Volts AC, 60 cycles
CRV 52093	220 Volts AC, 60 cycles
DZ-2	24 Volts DC/ 1.5 amps (Dyn)
GO-9	115 Volts AC, 600/800 cycles
GF-11	See RU-16
GF-12	See RU-17
GP-7	115 Volts AC, 800 cycles
RA-38	115 Volts AC, 60 cycles

UNIT:	POWER REQUIREMENTS:
RA-58	115 Volts AC, 60 cycles
RAK	115 Volts AC, 60 cycles
RAL	115 Volts AC, 60 cycles
RAZ	115 Volts AC, 60 cycles
RBL	115 Volts AC, 60 cycles
RBM	115 Volts AC, 60 cycles
RU-16	Receiver 12 Volts /7 amps (Dyn) Xmtrr 12 Volts 10 amps (Dyn)
RU-17	Receiver 24 Volts /5 amps (Dyn) Xmtrr 24 Volts 6 amps (Dyn)
RU-19	12 or 24 Volts DC (Dyn)
SCR-245	See BC-223 and BC-312
SCR-269	115 Volts AC, 400 cycles plus 14 or 28 Volts DC
SCR-274	See BC-453 thru BC-458
SCR-277	115 Volts - 500 cycles AC plus 14 Volts DC
SCR-284	6 Volts DC
SCR-508	See BC 603 and BC 604
SCR-522	Transmitting - 28 Volts /11.5 amps (Dyn) Receiving - 28 Volts 11.1 amps (Dyn)
SCR-528	See BC-603 and 604
SCR-538	See BC-603 and 604
SCR-542	Transmitting 14 Volts at 23 amps (Dyn) Receiving 14 Volts at 22.2 amps (Dyn)
SCR-608	See BC-683 and 684
SCR-628	See BC-683 and 684
SCR-808	See BC-923 and BC-924
SO-7M	115 Volts, 60 cycles AC
SO-7N	115 Volts, 60 cycles AC
SPR-2A	115 Volts, 60 cycles AC
TA-12B and C	24 Volts DC at 16.5 amps (Dyn)
TBS-5	115 Volts AC, 60 cycles for receiver 220 Volts AC, 60 cycles for transmitter
TBW	115 Volts AC, 600/800 cycles
TBY	Special battery pack and vibrator supply
Link FM Rec/ Xmtrr 1498	115 Volts, 60 cycles AC

NOTE: Special DC power units, supplying voltages and currents for most of the surplus equipments listed above, are available in kit form from Radio Products Sales, Inc., Los Angeles 15, California.

ARB Radio Receiver and Single Control Box

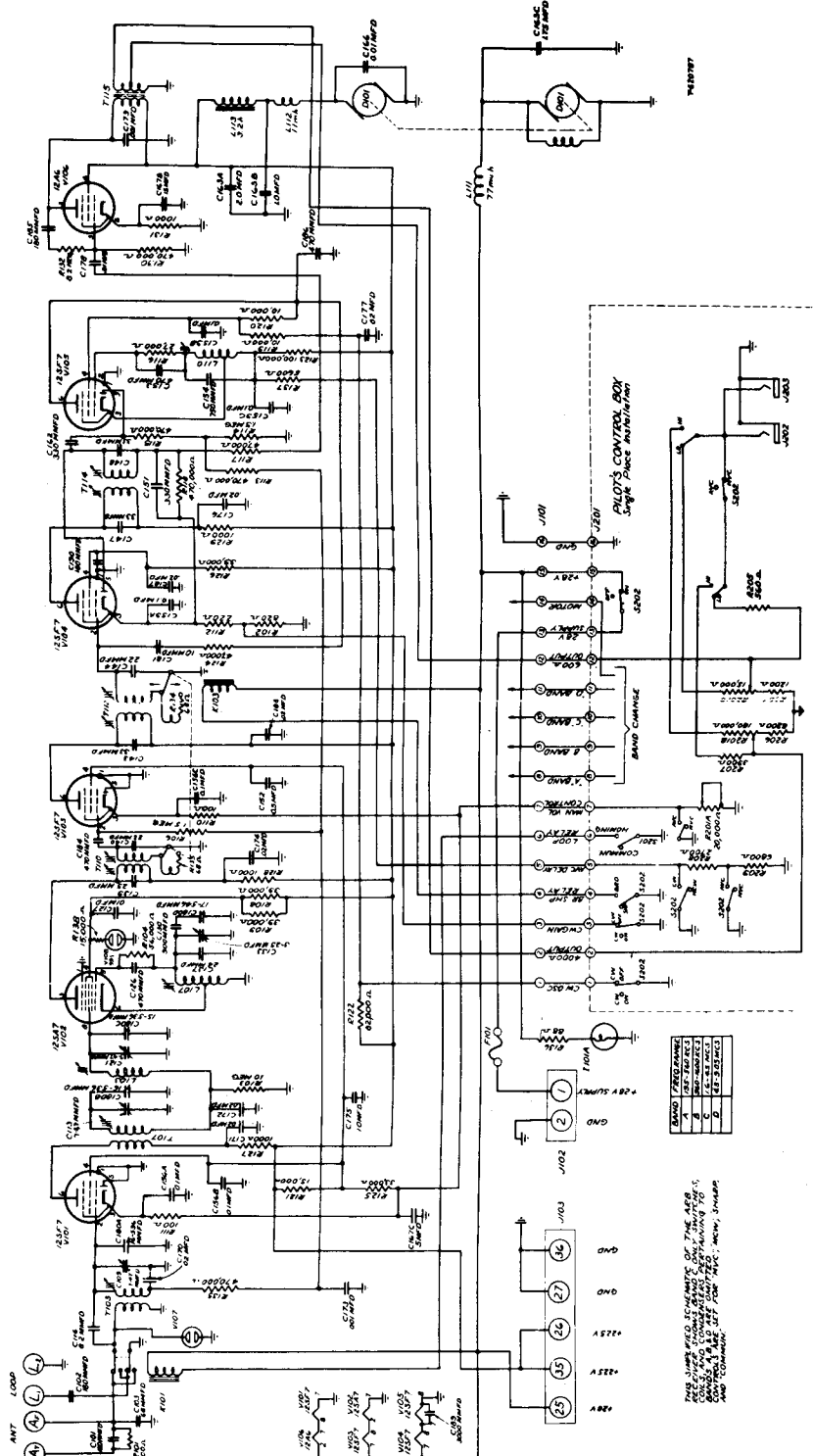

BAND	RESISTANCE
A	1000 Ω
B	2000 Ω
C	3000 Ω
D	4000 Ω

THIS NUMBERED SCHEMATIC OF THE ARB RADIO RECEIVER IS TO BE USED IN CONNECTION WITH THE CONTROL BOX. THE CONTROL BOX IS AVAILABLE FROM THE ARB COMPANY.

RADIOTELEPHONE LICENSE MANUAL

**PREPARES YOU FOR THE F.C.C.
RADIOTELEPHONE LICENSE
EXAMINATION**

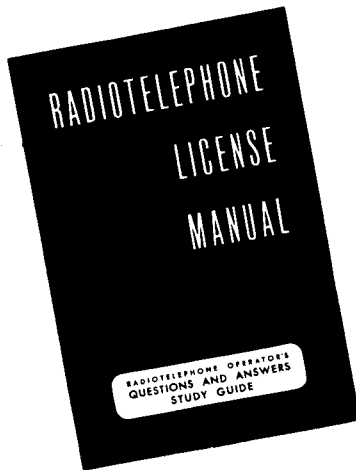

Now, in one convenient volume, complete study-guide questions with clear, concise answers for preparation for all U.S.A. commercial radiotelephone operator's license examinations.

CONTAINS FOUR ELEMENTS:

- I. QUESTIONS ON BASIC LAW
- II. BASIC OPERATING PRACTICE
- III. BASIC RADIOTELEPHONE
- IV. ADVANCED RADIOTELEPHONE

\$5.75 per copy



***Order from your favorite electronic parts distributor**
If he cannot supply, send us his name and your remittance, and we will supply; foreign, add 10%.

EDITORS and ENGINEERS, Ltd. Summerland, California

Dealers: Electronic distributors, order from us. Bookstores, libraries, newsdealers order from Baker & Taylor, Hillside, N.J. Export (exc. Canada), order from H.M. Snyder Co., 440 Park Ave. So., N.Y. 16.

Every

ELECTRONIC TUBE IN 3 MANUALS



WORLD'S RADIO TUBES

(RADIO TUBES VADE MECUM)

Characteristics of all existing radio tubes made in all countries. The world's most authoritative tube book. All types classified numerically and alphabetically. To find a given tube is only a matter of seconds! Also complete section on base connections. **\$6.00**



WORLD'S EQUIVALENT TUBES

(EQUIVALENT TUBES VADE MECUM)

All replacement tubes for a given type, both exact and near-equivalents (with points of difference detailed). From normal tubes to the most advanced comparisons. Also military tubes of 7 nations, with commercial equivalents. Over 43,900 comparisons! **\$6.00**



WORLD'S TELEVISION TUBES

(TELEVISION TUBES VADE MECUM)

Characteristics of all TV picture and cathode ray tubes. Also special purpose electronic tubes. Invaluable to technicians and all specialists in the electronic field. **\$6.00**



***Order from your favorite electronic parts distributor**

If he cannot supply, send us his name and your remittance, and we will supply; foreign, add 10%.

EDITORS and ENGINEERS, Ltd. Summerland, California

Dealers: Electronic distributors, order from us. Bookstores, libraries, newsdealers order from Baker & Taylor, Hillside, N.J. Export (exc. Canada), order from H.M. Snyder Co., 440 Park Ave. So., N.Y. 16.