

# Model T-UG8 (Transistorized Desk Stand) Model T-UG8-D104 (Transistorized Desk Stand & D-104 Micro.)

**ASTATIC**  
Models  
T-UG8 &  
T-UG8-D104

## GRIP, PUSH, TOUCH OR LOCK ON-TO-TALK TYPE

● THE STATUS SYMBOL FOR C.B., HAM AND PROFESSIONAL USERS ●

### GENERAL DESCRIPTION

The T-UG8-D104 is a combination of the original super talk-power D-104 microphone with the transistorized version of the rugged and versatile UG-8 Stand (T-UG8). The result is an ideal base station microphone for CB, Amateur or other communications applications. Its relatively low impedance output can be fed into any communication receiver or transmitter. The tailored response and high gain ensures excellent talk-power and intelligibility -- and full modulation.

The T-UG8 Stand has a built-in two stage silicon transistor amplifier having high impedance input. The output impedance is suitable for the inputs of all commercial transmitters or transceivers. The high gain available ensures desired modulation capability. The gain can be readily adjusted for the desired modulation. The control is recessed to avoid accidental changes.

The unique Astatic "Plug-In" microphone design permits the use of any one of a series of available compatible model microphones.

Crystal	D-104 or T-3
Ceramic	D-104C or 10C
Dynamic	10DA, DN-HZ or DN-50
Dynamic Cardioid	77L or 811

### FEATURES and SPECIFICATIONS

- D-104 MICROPHONE: High quality metal sealed type crystal.
  - MICROPHONE RECEPTACLE: On top of stem, offers instant microphone change versatility.
  - SWITCH BAR FOR EASY CONTROL: Can be locked "ON" by moving "slide clamp" to top of stand.
  - HEAVY, TIP-FREE BASE: Sturdy, die-cast zinc construction protects the microphone from "tip over" damage.
  - ATTRACTIVE FINISH: Durable polished chrome mast with gray Hammerlin base.
  - NOISE-FREE AND CLICK-FREE SWITCHING: Uses heavy duty DPDT leaf type switch with fine silver contacts. Low contact resistance of 20 milliohms; will not oxidize and requires no cleaning.
- High current capability for relay operation allows up to 3 amperes DC and non-inductive AC loads with complete safety.\*\*
- HIGH GAIN, TWO TRANSISTOR AMPLIFIER.
  - RECESSED VOLUME CONTROL TO AVOID ACCIDENTAL CHANGES.
  - SIZE: See Fig. 1.
  - WEIGHT: T-UG8 2 lbs. 1½ oz. (with cable).  
T-UG8-D104 2 lbs. 11½ oz. (with cable).

\*\* Caution Note: Care should be exercised in exciting relays with AC because of induced hum fields.

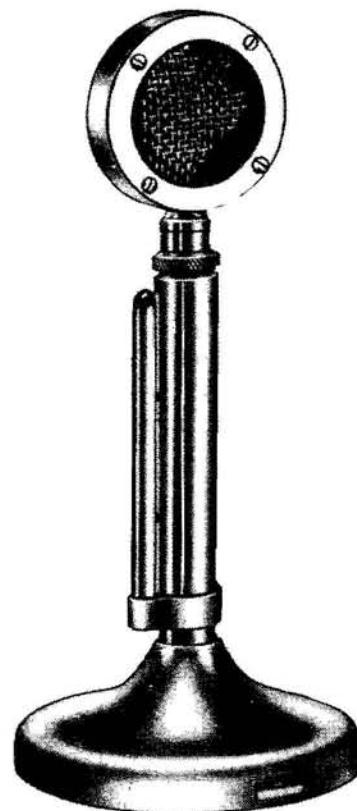

### ELECTRONIC SPECIFICATIONS

- FREQUENCY RESPONSE: T-UG8 essentially flat 200 HZ-20KHz. T-UG8-D104 tailored; See Fig. 4.
- OUTPUT LEVEL TUG8-D104 @ 1000 Hz:  
1 meg. Load = -20 dB re 1V/microbar  
5000 Load = -26 dB re 1V/microbar
- POLAR PATTERN: Semidirectional.
- OUTPUT IMPEDANCE: 5000 ohms or less.
- AMPLIFIER VOLTAGE GAIN: 26dB.
- BATTERY TYPE: 9 volt; Eveready 216, Burgess 2V6, Ray-O-Vac 1604, etc.
- BATTERY DRAIN: 1.2 ma.
- BATTERY LIFE: Approx. 6 mo.; based on normal usage.
- TEMPERATURE RANGE: Approx. -30°C. to +45°C. (Limited by crystal).
- "RELAY" or "ELECTRONIC" hookup: By internal switch.
- CABLE: Coiled cord; black vinyl jacket; single conductor shielded plus two unshielded conductors.



**THE ASTATIC CORP.**

CONNEAUT, OHIO • U.S.A. 44030

IN CANADA: Canadian Astatic, Ltd.,  
1820 Ellesmere Road, Scarborough, Ontario

MANUFACTURERS OF PHONOGRAPH CARTRIDGES  
NEEDLES • PICKUPS • MICROPHONES

PHONE: 593-1111 Area Code 216

EXPORT SALES: Morhan Exporting Corporation  
270-78 Newtown Road, Plainview, New York 11803

# ASTATIC specifications: T-UG8 & T-UG8-D104

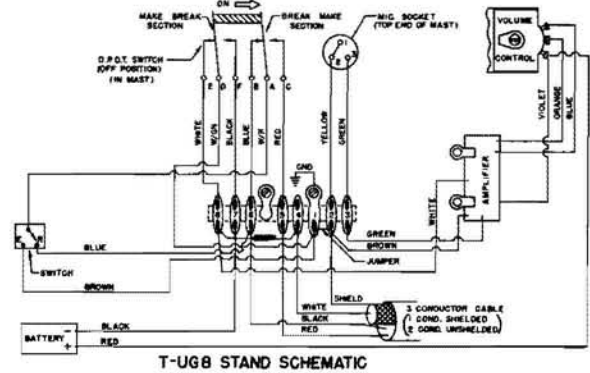
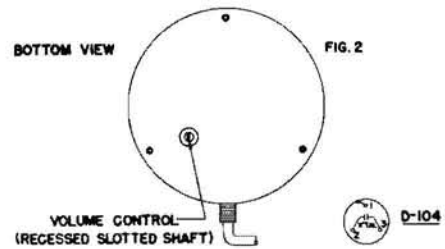
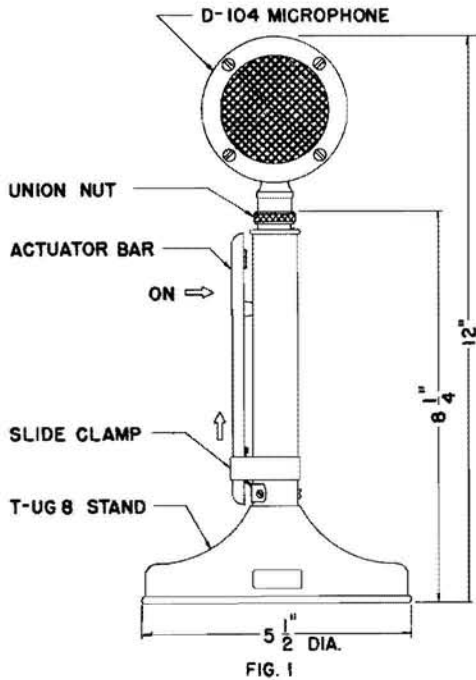

TYPICAL D-104 RESPONSE - FREQUENCY CHARACTERISTICS

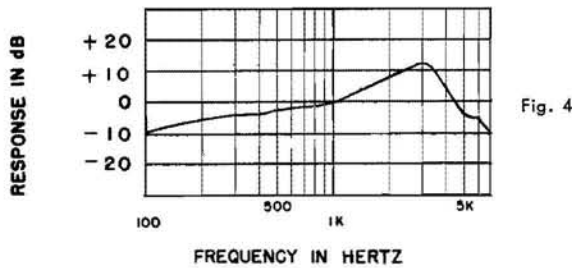

NOTES:

1. Do not subject the crystals to temperatures over 45°C.; permanent damage may result.
2. The D-104 is one of a group of "Plug-In" microphones compatible with the "G" series of stands. It plugs into the top of the mast and is locked on by means of the union nut (See Fig. 1).

"RELAY" or "ELECTRONIC" SWITCHING CONTROL: "Relay" operation connects BLACK to RED cable wires when the actuator bar is operated. "Electronic" operation grounds the RED to shield when the bar is operated. When released, BLACK is grounded.

THE INTERNAL SLIDE SWITCH is placed in the "R" (RELAY) position at the factory. If electronic type control is desired, remove the bottom plate and slide the slide switch to "E" position. Replace the bottom plate.

CABLE CONNECTOR WIRING: WHITE to audio input, SHIELD to ground, RED and BLACK to control circuits.

OPERATION: ASTATIC "PLUG IN" MICROPHONE types are pre-wired for use with the T-UG8 Stand. Choose one of the compatible microphones from the listing shown on the front side. (For "CB" and "Communications" transmissions, many use the well known D-104 microphone.) Plug into and lock onto head of stand.

VOLUME CONTROL located in the base to eliminate accidental changes should be set at minimum gain - complete COUNTER CLOCKWISE position when viewed from bottom of stand. TURN "ON" the transmitter and squeeze the actuator bar in direction as noted in Fig. 1. Operating the actuator bar operates the transmit-receive circuits. While talking into the microphone at normal operating distance, slowly turn the volume control (Fig. 2) up until modulation is at desired level. Once properly set, the volume control should not require resetting under equivalent operating conditions.

For desired sensitive touch control - move slide clamp up in short steps to desired tension. For continuous or VOX operation - push slide clamp up to top.

BATTERY REPLACEMENT: 9 volt battery, located inside the base of stand may be replaced with locally available Eveready 216, Burgess 2V6, Ray-O-Vac 1604, or equivalent.

To replace the battery, remove the bottom cover by removing the three cover screws.

## TG-KIT, TU-KIT, T-UG8 STAND

### Special Instruction Notes

1. The combination of these amplifiers with high level microphones may result in critical gain setting. A "L" pad comprising two resistors results in much less critical adjustment.

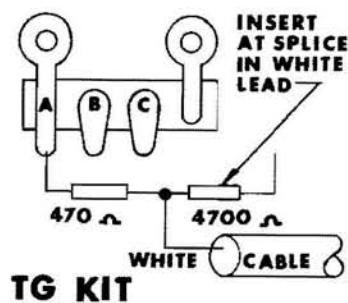
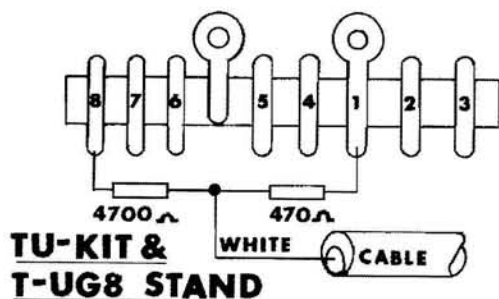

Insert 4700 ohms in series with the WHITE cable lead. Shunt 470 ohms from WHITE cable lead to ground.

2. When wiring microphone cables and plugs to equipment, the color codes for the cable and for the equipment are not necessarily the same. Be careful to connect wires to the correct terminals.
3. Occasionally R.F. feedback presents problems. The solution is basically good installation.
  - a. Antenna Feedline standing wave ratio must be low.
  - b. Good grounding eliminates a "hot" transmitter chassis condition which can couple R.F. into unwanted places. On base stations multiple grounds with different length line to each ground is good practice.
  - c. In stubborn cases it may be necessary to alter microphone cable length to a non-resonant length. A coil cord in lieu of a straight cable can be a solution.
  - d. In extreme cases it has been found that installation of an R.F. filter in the transmitter at the audio input eliminates R.F. to audio input stage. This filter comprises a 10K ohm resistor in series and a .001 mfd. capacitor from the microphone input to ground.

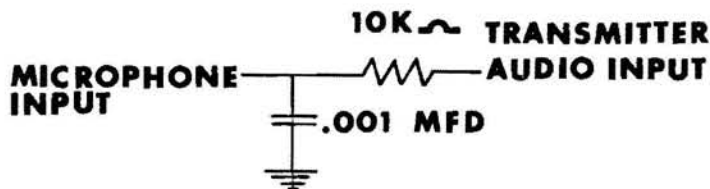

(OVER)

Form No. 90-5

TG-KIT, TU-KIT, T-UG8 STAND  
Special Instruction Notes Continued

4. Some transceivers (such as Messenger 124) have the microphone ground at a D.C. potential differing from the outer case. With a metal housed microphone there is a possibility of shorts to the outer case blowing fuses or damaging equipment. When using equipment of this type, write to the factory for instructions. Enclose a schematic and describe the problem.
5. Some transceivers are wired so that microphone input is also receiver audio. The microphone preamp (T-UG8 etc.) presents a short circuit to microphone output during receive mode.

If, when the microphone preamp is connected to the transceiver, receiver output drops to zero, cut the WHITE cable lead at the terminal inside the microphone base. Receiver volume will go to normal. Install a  $\frac{1}{2}$  watt composition resistor in series with the WHITE lead where it was cut. Try several values to determine the smallest value resistor that can be inserted without appreciable effect on receiver performance. Install this resistor permanently.

6. On initial setup it is a good practice to turn gain completely down. After turning on the transmitter, slowly turn the gain up until desired modulation level is reached. This procedure aids in getting gain properly set without going through periods of excessive distortion and over-modulation.