



2-METER FM TRANSCEIVER

Model TR-7400A



OPERATING MANUAL

INTRODUCTION

Your KENWOOD Model TR-7400A is a high-quality 2-meter transceiver for use in amateur radio mobile stations as well as fixed stations. It contains a PLL frequency synthesizer developed and engineered through KENWOOD's elaborate VHF technology to provide high performance and outstanding technical characteristics.

The TR-7400A is capable of transmitting or receiving F3 FM signals on up to 800 Channels at intervals of 5 kHz, having 25W RF output power.

CONTENTS

SPECIFICATIONS	3
SECTION 1 PREPARATION FOR USE	4
1.1 Accessories	
1.2 Tone Squelch	
1.3 Antenna	
1.4 Installation Caution	
SECTION 2 CONTROLS AND WHAT THEY DO	4
2.1 Front Panel	
2.2 Rear Panel	
2.3 Side Panel	
SECTION 3 GENERAL TIPS ON INSTALLATION	7
3.1 Mobile Use	
3.2 Fixed-Station Use	
SECTION 4 OPERATION	8
4.1 Receiving	
4.2 Transmitting	
4.3 How to Use the TX Offset Switch	
4.4 How to Use the Hi/Low Selector Switch	
4.5 How to Use the Tone Selector Switch	
4.6 Description of "Unlock" Indicator	
4.7 How to Use the Tone Pad	
SECTION 5 ADDITIONAL INFORMATION	12
BLOCK DIAGRAM	13
TOP & BOTTOM VIEW OF THE TR-7400A	14
SCHEMATIC DIAGRAM	15

TR-7400A SPECIFICATIONS

GENERAL

Semiconductors	Transistors	58
	FETs	8
	ICs	19
	Diodes	63
Frequency Range	144.00 to 147.995 MHz	
Frequency Synthesizer	Digital (TTL Logic) control of phase locked VCO	
Synthesizer Stability	Less than ± 750 Hz at 25°C	
Mode	FM	
No. of Channel	800	
Operating Temperature	-20 to +50°C	
Power Voltage	11.5 VDC to 16.0 VDC (13.8 VDC as reference)	
Grounding	Negative grounding	
Antenna Impedance	50 Ω	
DC Current	Less than 1A in receive with no input signal Less than 8A in transmit (HI) Less than 4.5A in transmit (LOW) (at 13.8 VDC)	
Dimension	182 mm (7-3/16") wide 74 mm (2-7/8") high 270 mm (10-5/8") deep	
Weight	Approx. 2.8 kg (6.2 lbs.)	

TRANSMIT SECTION

RF Output Power	High	25 watts (min.)
	Low	approx. 5 watts (adjustable up to 15 watts)
Modulation	Variable reactance direct shift	
Max. Frequency Deviation	± 5 kHz	
Spurious Radiation	Less than -60 dB	
Touch Tone Input Impedance	600 Ω	
Microphone	Dynamic microphone with PTT switch, 500 Ω	

RECEIVE SECTION

Circuitry	Double superheterodyne	
Intermediate Frequency	1st IF	10.7 MHz
	2nd IF	455 kHz
Sensitivity	Less than 0.4 μ V for 20 dB quieting (Less than 1 μ V for 30 dB S/N)	
Squelch Sensitivity	Less than 0.25 μ V	
Pass Band Width	More than 12 kHz at 6 dB down	
Selectivity (2 Signal)	More than 72 dB at 30 kHz of adjacent channel	
Image Rejection	More than 70 dB	
Spurious Interference	More than 60 dB	
Intermodulation	More than 66 dB	
Audio Output	More than 1.5 watts across 8 Ω load (10% distortion)	

OPTION

i) Tone Squelch	
Tone Deviation	± 0.5 kHz (adjusted)
Encorder Response	Less than 0.5 sec.
Frequency Stability	Less than $\pm 1\%$
Tone Squelch Open Sensitivity	Less than SINAD 10 dB
Tone Distortion	Less than 5%
ii) Tone Burst	
Burst Time	Approx. 0.5 sec. (adjusted)

NOTE: The circuit and ratings may change without notice due to development in technology.

SECTION 1. PREPARATION FOR USE

1.1 ACCESSORIES

Carefully unpack your TR-7400A Transceiver and check that it is supplied with the following accessories:

- (1) Dynamic microphone equipped with
4-pin plug 1 piece
- (2) Mounting bracket 1 piece
- (3) Mounting parts
Screws, 6 mm diameter 4 pieces
Plain washers, 6 mm diameter 4 pieces
Spring washers, 6 mm diameter 4 pieces
Nuts, 6 mm diameter 4 pieces
- (4) Stand-off bracket 1 piece
- (5) Label 1 sheet
- (6) Spare fuse, 10A 1 piece
- (7) DC power cord with plug and fuse 1 piece
- (8) Miniature plug for external speaker 1 piece
- (9) Miniature plug for touch tone pad 1 piece
- (10) Plug-equipped PC board for
tone squelch 1 sheet
- (11) Operating manual 1 copy

1.2 TONE SQUELCH

The TR-7400A is designed not only for normal carrier type

squelch operation, but also for tone squelch which operates with the installation of the optional tone module. If you operate the TR-7400A setting tone selector "SQU" without the module, you will find it not to be in the normal receive mode. Detail is shown in page 10.

1.3 ANTENNA

Any 50 ohm 2-meter antenna system may be used with your TR-7400A. The 50 ohm coaxial cable should be kept as short as possible in order to minimize line loss. Attach a UHF type connector (PL-259) to the coaxial cable for easy connection to the receptacle on the transceiver.

1.4 INSTALLATION CAUTION

Your TR-7400A Transceiver to be operated as a mobile station should be securely mounted under the dashboard (or similar location) using the accessory mounting bracket and bolts. Improper installation will result in damage to the transceiver and dashboard. Consideration must be given to the dashboard material prior to installation. More detailed information on installation will be found in SECTION 3.1, the "MOBILE USE", page 7.

SECTION 2. CONTROLS AND WHAT THEY DO

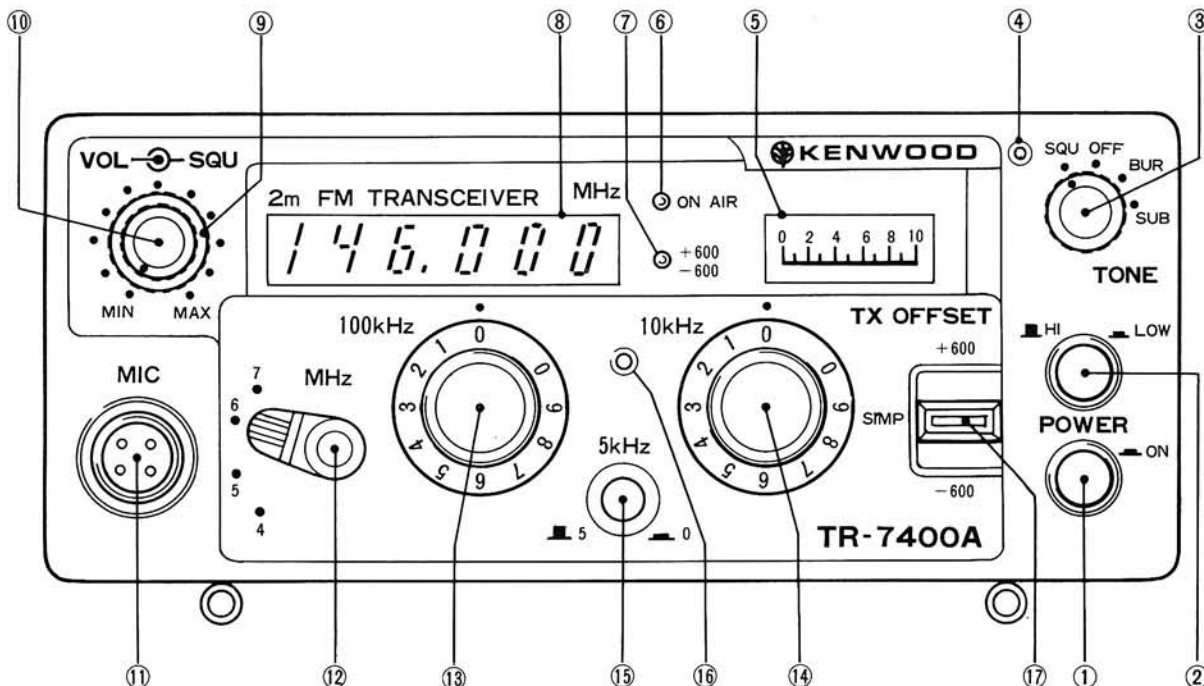

Fig. 1 Front Panel View

2.1 FRONT PANEL

- ① POWER Switch – Turns power on when pressed in.
- ② HI/LOW pushbutton Switch (Refer to the “HOW TO USE THE HI/LOW SELECTOR SWITCH” section, page 10). – Used to select high (25W) or low (5W) RF output Power.
- ③ TONE Selector (Refer to the “HOW TO USE THE TONE SELECTOR SWITCH” page 10). – Four position switch used to select type of squelch desired:
SQU: Continuous tone controlled squelch (C.T.C.S.) on transmit and receive (Optional).
OFF: Carrier Squelch operation.
BUR: Tone burst operation (Optional).
SUB: C.T.C.S. on transmit only (Optional).
- ④ Tone Squelch Indicator – A light-emitting diode (LED) which lights when the TONE Selector is set to the SQU position.
- ⑤ Meter – Indicates signal strength as an S meter during receive and relative RF output power during transmit. The meter function is automatically switched using the microphone push-to-talk switch.
- ⑥ ON AIR Indicator – A light-emitting diode which lights during transmit.
- ⑦ Repeater Indicator – A two-color light-emitting diode which indicates the type of repeater offset. It is red when the TX OFFSET Switch ⑰ is set to +600 or green when the switch is set to –600.
- ⑧ Digital Frequency Display – Indicates receive frequency only in 6 digits when the POWER Switch ① is ON. The display is covered with a smoked acrylic plate.
- ⑨ SQU Control (Outer ring) – This is a normal carrier-type squelch control which activates the squelch circuit when turned clockwise.
- ⑩ VOL Control (Inner knob) – An AF volume control used in the receive mode of operation. Clockwise turning increases the AF volume.
- ⑪ MIC connector – Accepts the standard 4-pin mic. plug supplied with the TR-7400A.
- ⑫ MHz Selector Switch – Used to select the desired band. (144, 145, 146, 147 MHz indicated as 4, 5, 6, and 7 respectively).
- ⑬ 100 kHz Selector Switch – Used to select a desired channel in units of 100 kHz, graduated in 11 positions: 0 through 9 and 0.
- ⑭ 10 kHz Selector Switch – Used to select a desired channel in units of 10 kHz, graduated in 11 positions: 0 through 9 and 0.
- ⑮ 5 kHz Offset Switch – Used to select the least significant digit, 0 or 5 kHz, of the channel frequency.
- ⑯ Unlock Indicator, (Refer to Section 4.6 the “DESCRIPTION OF UNLOCK INDICATOR”, page 12). – A light-emitting diode, indicates when the PLL circuit is in the unlock condition. There is no synthesizer output in the unlock condition. Note, however, that the PLL circuit is normal if the indicator lights momentarily when a channel selector switch is changed.
- ⑰ TX OFFSET Switch (Refer to Section 4.3, the “HOW TO USE THE TX OFFSET SWITCH”, page 9). – This switch selects the type of frequency offset desired.

+600 kHz switches the transmit frequency UP 600 kHz from the receive frequency.

SIMP stands for simplex operation.
The receive and transmit frequencies are the same.

–600 kHz automatically switches the transmit frequency down 600 kHz from the receive frequency.

2.2 REAR PANEL

- ⑱ DC Power Connector – Accepts normal DC operating voltage through the DC power cord supplied with the TR-7400A.
- ⑲ Heat Sink – Radiates heat produced by the final transistors.
- ⑳ ANT Connector – For connection of any 50 ohm 2-meter antenna.

2.3 SIDE PANEL

- ㉑ EXT SP Connector – External AF output (8 ohm).
- ㉒ TONE PAD Connector – A tone pad input for “Auto-patch” operation (600 ohm – Refer to Section 4.7 the “HOW TO USE THE TONE PAD” on page 12.)
- ㉓ Mounting Rail – Used to install the transceiver on the supplied mounting bracket.
- ㉔ Snap Lock – Used to lock the transceiver body on the supplied mounting bracket.
- ㉕ Stand-off – Can be attached to your TR-7400A during operation to provide a convenient angle of viewing for the operator.

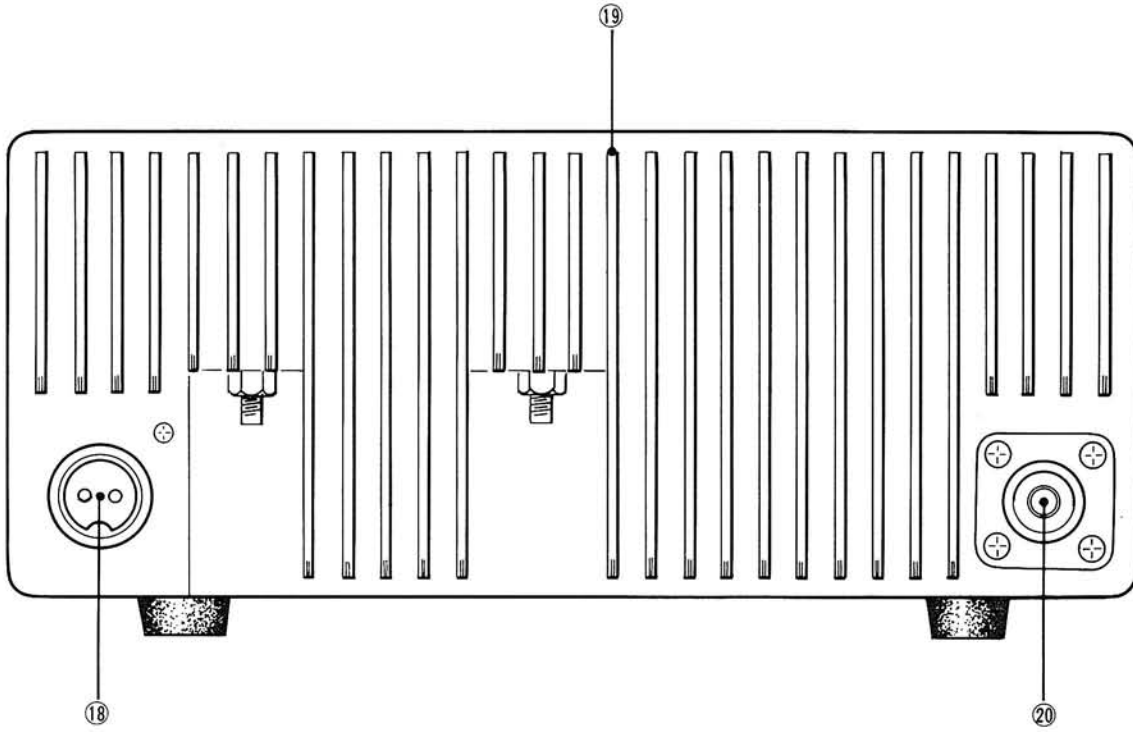

Fig. 2 Rear Panel

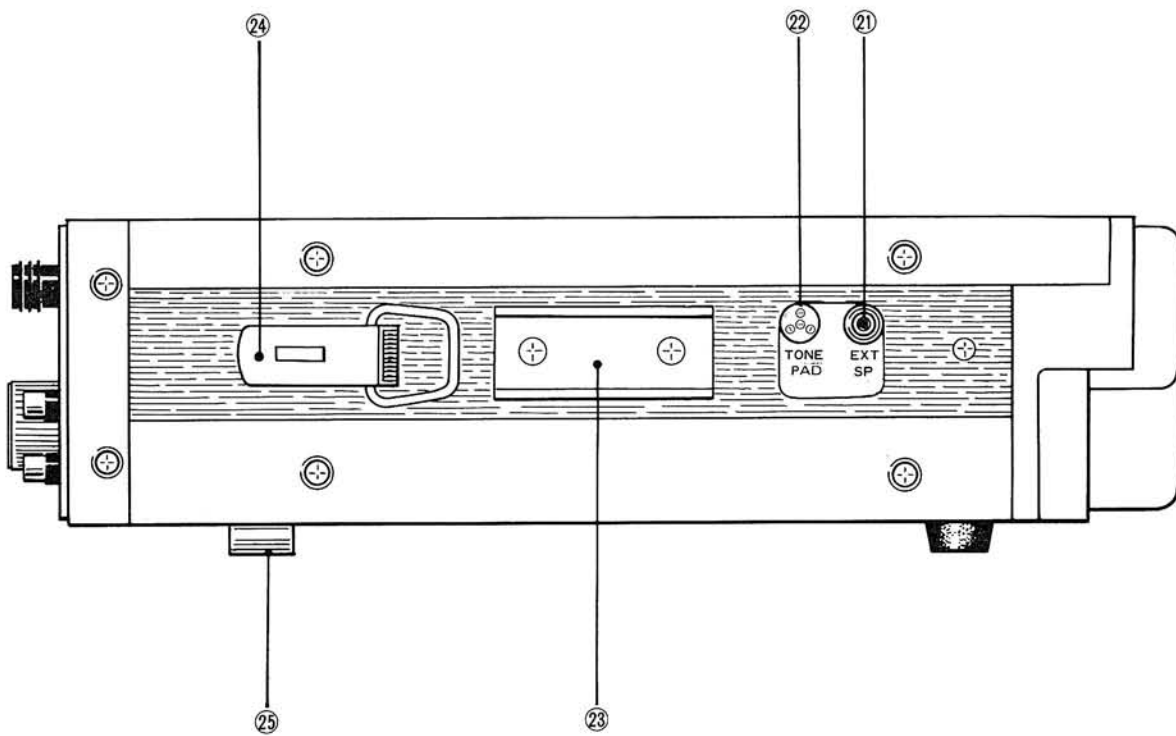

Fig. 3 Side Panel

SECTION 3. GENERAL TIPS ON INSTALLATION

3.1 MOBILE USE

1. Installation Position

Your TR-7400A may be installed under the dashboard of your vehicle for convenient operation. Be sure that its position does not restrict your leg movement to the brake pedal. A typical installation is shown in Fig. 4.

2. How to Install (Fig. 5)

IMPORTANT

The TR-7400A is designed for a negative ground installation.

- Securely install the mounting bracket with the supplied bolts and nuts.
- Insert the transceiver into the mounting bracket using the mounting rails.
- Adjust the rail angle for the desired position of the transceiver. This assures operational convenience and safety while driving the vehicle.
- Unfold each snap lock, hook on the pawl, then clamp the snap lock. Both locks should be fully fastened to get full effect of the spring action.

CAUTION

Be sure that both rails are fully seated in the mounting bracket before clamping the locks.

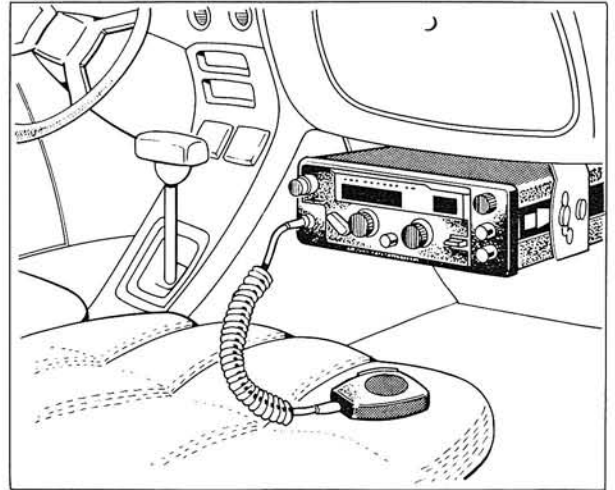

Fig. 4 A Typical Installation

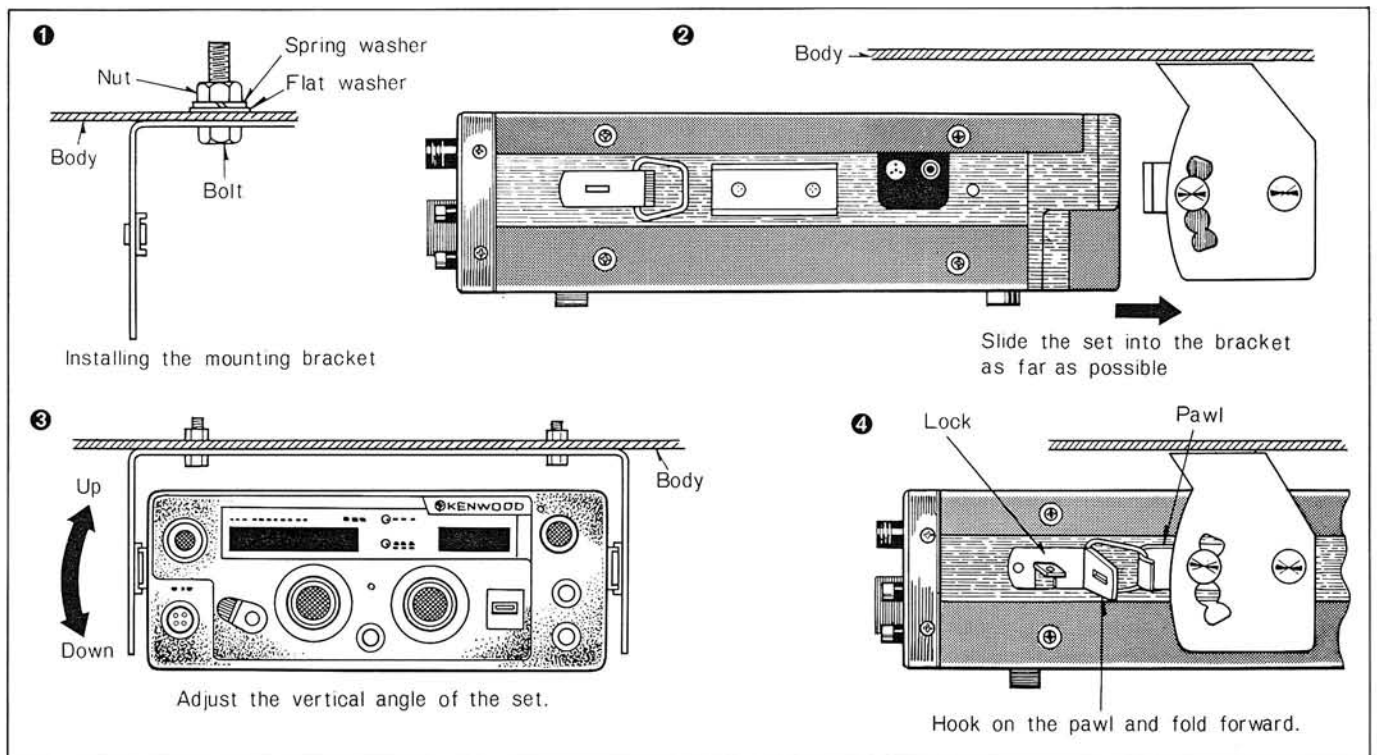

Fig. 5 How to Install

3. Connecting the Power Supply

Connect the supplied power cable securely from your transceiver to the battery/power supply posts. Make certain that the red lead is placed to the positive (+) post and the black lead to the negative (-) post. If necessary, attach the power cable to the vehicle body at the appropriate points to avoid dangling.

NOTES

1. The power cable should be as short as possible.
2. An alternative way of obtaining power is to plug the cigar lighter arranged in most vehicles. Such a plug, shown in Fig. 6, is available at auto accessory shops or electronics parts stores.

3.2 FIXED-STATION USE

If you operate the TR-7400A as a fixed station, attach the supplied Stand-off bracket (25) to it as illustrated in Fig. 6. The TR-7400A is designed so as to be used with a DC power supply having a current capacity of around 10A at the rated operating voltage of 13.8V.

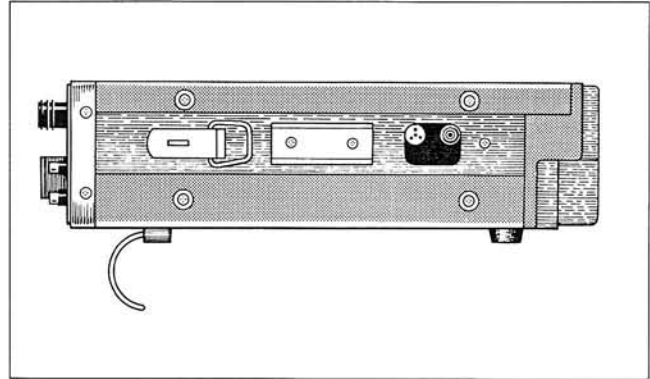

Fig. 6 Use of Stand-off Bracket

SECTION 4. OPERATION

4.1 RECEIVING

1. Connect the supplied power cable to the DC power connector (18) and the antenna cable to the ANT connector (20). Select a DC power supply or battery pack having 8 to 10A current capacity at 13.8V.

CAUTION

Make certain that connection of the positive (+) and negative (-) power cable leads have been connected properly.

2. Depress the POWER ON Switch (1). The digital frequency Display (8) will indicate the frequency and the meter (5) will be illuminated.
3. Set the TONE Selector Switch (3) to OFF.
4. Turn the SQU Control (9) fully counterclockwise.
5. Turn the VOL Control (10) clockwise until the noise comes up to a comfortable level.
6. Set the MHz, 100 kHz and 10 kHz Selector Switches (12), (13), (14) and 5 kHz Offset Switch (15) to the receive frequency. If an incoming signal is received, the Meter (5) will indicate the signal strength.
7. To eliminate the noise heard with no input signal, gradually turn the SQU Control (9) clockwise until the noise threshold is reached.

NOTE

Your transceiver is normal even if the Unlock Indicator (16) located on the center of the front panel lights momentarily after selecting a frequency. For more detailed information, refer to Section 4.6, the "DESCRIPTION OF UNLOCK INDICATOR", page 12.

4.2 TRANSMITTING

1. Plug the supplied microphone cable plug into the MIC Connector (11).
2. Set the TONE Selector Switch (3) to OFF.
3. Set the TX OFFSET Switch (17) to SIMP.
4. Set the MHz, 100 kHz and 10 kHz Selector Switches (12), (13), (14) and 5 kHz Offset Switch (15) to a desired channel.
5. Depress the microphone push-to-talk switch to operate the TR-7400A in the transmit mode. The ON AIR Indicator (6) will light and the meter (5) pointer will deflect to indicate the RF output power.
6. The best separation between your mouth and microphone is 5 to 10 cm.

NOTE

You can check the operational condition of the antenna system by observing the reading on a standing-wave ratio (SWR) meter. It is recommended that the antenna system SWR is 1.5 : 1 or less.

The transmit power will be reduced by a protection circuit when the SWR is too high. The TR-7400A is designed so that the Meter ⑤ will read "8" when operating high power (25 watts) into a 50 ohm load. The antenna system, therefore, is acceptable if the meter reads around this value. The meter, in this sense, acts as an SWR indicator.

4.3 HOW TO USE THE TX OFFSET SWITCH

The TX OFFSET Switch ⑰ used mainly for repeater operation, has three positions:

SIMP: Your TR-7400A operates in the usual simplex mode. That is, the RF receive and transmit frequencies are the same.

This frequency is indicated on the Digital Frequency Display ⑧.

+600: Your Transceiver can be used for repeater operation. The Repeater indicator ⑦ will light red. The RF reception frequency is the same as indicated on the Digital Frequency Display ⑧, but the RF transmit frequency is 600 kHz higher than indicated.

-600: Your Transceiver can be used for repeater operation. The Repeater indicator ⑦ will light green. The RF receive frequency is the same as indicated on the Digital Frequency Display ⑧, but the RF transmit frequency is 600 kHz lower than indicated.

NOTE

The TONE Selector Switch ③ can also be used for repeater operation. Please refer to Section 4.5, the "HOW TO USE THE TONE SELECTOR SWITCH", BUR position, page 10.

CAUTION

1. The TX OFFSET Switch ⑰, as described above, shifts 600 kHz higher or lower only the RF transmit frequency of your Transceiver irrespective of the positions of the MHz, 100 kHz, and 10 kHz Selector Switches ⑫, ⑬, ⑭ and 5 kHz Offset Switch ⑮, leaving the RF receive frequency as displayed. In general, repeater operation is done by setting the TX OFFSET Switch ⑰ to +600 for the Frequency range of 147.000 to 147.390 MHz and to -600 for 146.610 to 147.000 MHz (see Fig. 7).
2. In using the TX OFFSET Switch ⑰, particular care should be observed not to transmit out of the frequency band of 144 to 148 MHz.

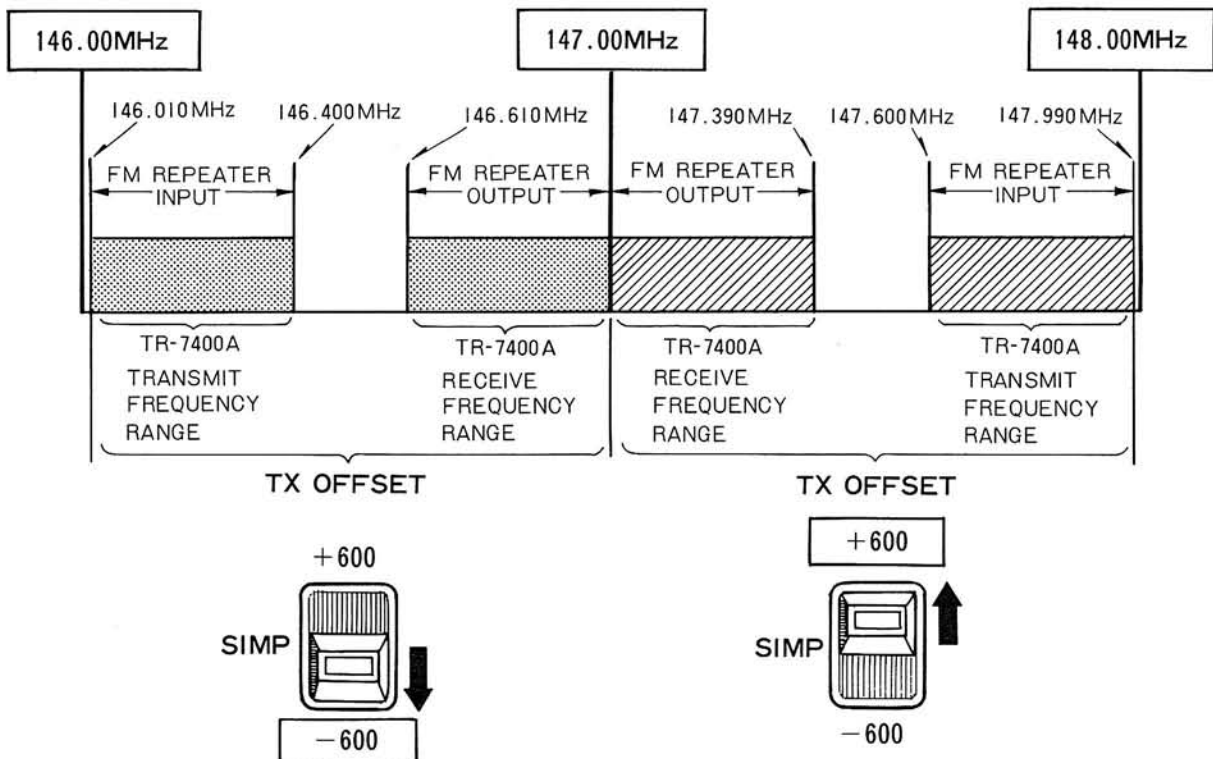

Fig. 7 Layout of the Two Meter Band

4.4 HOW TO USE THE HI/LOW SELECTOR SWITCH

Occasionally, it is desirable to lower the RF transmit power to reduce battery drain or drive an external amplifier. Depressing the HI/LOW Selector Switch ② to LOW will reduce the RF transmit power from 25W to 5W, which is read as "3" approximately on the Meter ⑤.

4.5 HOW TO USE THE TONE SELECTOR SWITCH

The TONE Selector Switch ③ has four positions:

SQU: Sets your transceiver to the "tone squelch" mode of reception with the Tone Squelch Indicator ④ lit red. The tone squelch circuit built into the TR-7400A, called the "CTCS" (continuous tone controlled squelch) is operated by the tone signal of a specific frequency that has been superimposed with the your voice signal onto the carrier in the TX unit and is separated in the RX unit. You may select any desired tone frequency by choosing one of the tone squelch active filters listed as options available for the TR-7400A in Table 1.

Figure 9 shows installation of the tone squelch active filter on the PC board supplied with your TR-7400A.

Figure 8 shows installation of the PC board in the RX unit (X55-1150-10).

Frequency (Hz)	Parts number
88.5	L79-0408-05
94.8	L79-0409-05
100.0	L79-0410-05
103.5	L79-0411-05
107.2	L79-0412-05
110.9	L79-0413-05
114.8	L79-0414-05
118.8	L79-0415-05
123.0	L79-0416-05
127.3	L79-0417-05
131.8	L79-0418-05
136.5	L79-0419-05
141.3	L79-0420-05
146.2	L79-0421-05
151.4	L79-0422-05
156.7	L79-0423-05

Table 1 Tone Squelch Active Filter List

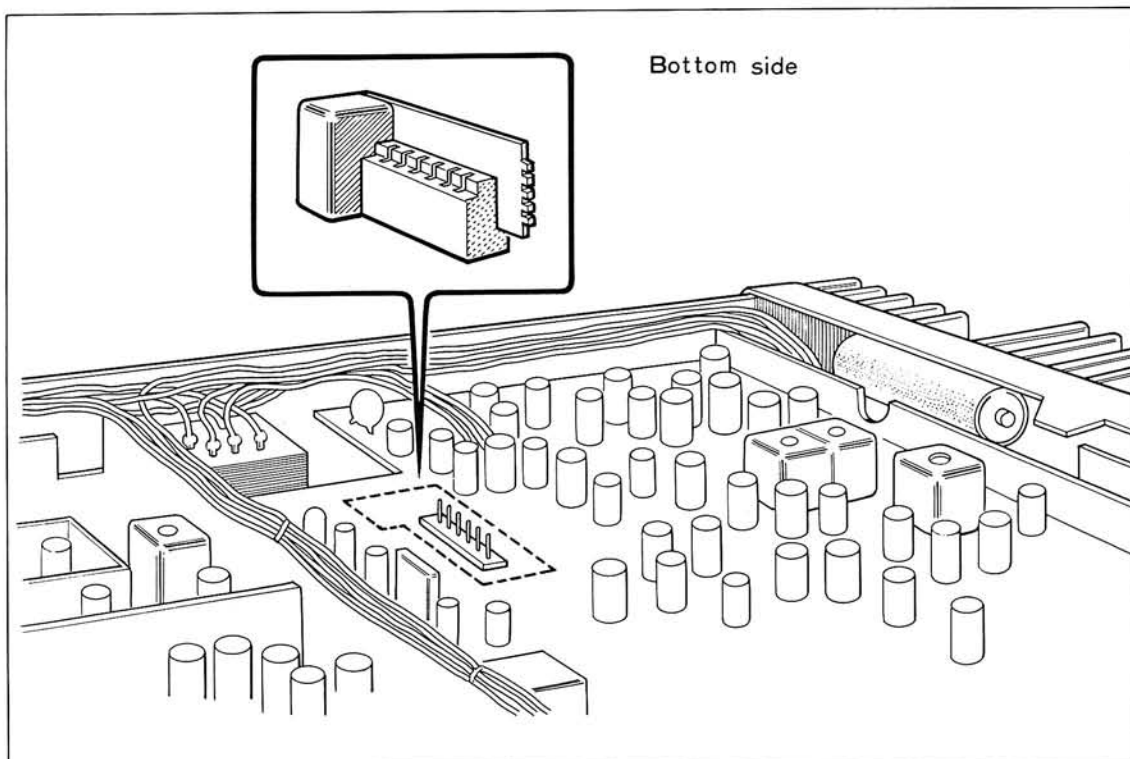

Fig. 8 How to Install the Tone Unit

Split the supplied PC board into two sections as shown in Fig. 9. You now have two separate tone squelch boards for ease in changing tone frequencies.

Some tone squelch circuits have an appreciable time lag.

The active filter circuit employed in the TR-7400A, however, features comparably short time lag.

NOTE

The SQU Control ⑨ has no effect when the TONE Selector Switch ③ is at SQU.

OFF: Sets your transceiver in the normal carrier-type squelch mode of reception with the SQU Control ⑨ turned clockwise generally to the noise threshold.

BUR: Sets your transceiver to the carrier-type squelch mode of reception as with the OFF position.

In the transmit mode of operation, your transceiver superimposes an additional tone burst signal when tone burst access is desired. The tone burst signal is generated for about 0.5 seconds when a tone oscillator module (option) is plugged into the monofork socket on the TX unit (X56-1230-10) and the microphone push-to-talk switch is depressed for transmit as illustrated in Fig. 10. For example, if you make use of a repeater station which receives a 146.34 MHz incoming signal, transmits a 146.94 MHz signal, and uses a 1,800 Hz tone burst access, install an 1,800 Hz tone burst module into the TX unit as illustrated in Fig. 10. Second, set the TX OFFSET Switch ⑰ to -600. Then, you can operate through this repeater. You may select any desired tone burst frequency from those listed as options available for the TR-7400A in Table 2.

SUB: Sets your transceiver to the carrier-type squelch mode of reception as with the OFF position. In the transmit mode of operation, a subaudible tone is superimposed on your RF output signal. The tone frequency is determined by the tone squelch active filter installed in the RX unit (X55-1150-10). See Fig. 8.

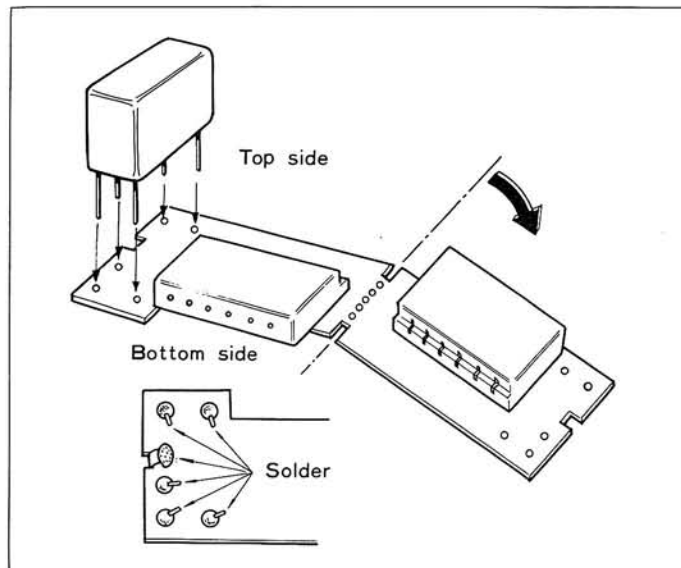

Fig. 9 How to Use the Supplied PC Board

Frequency (Hz)	Parts number
1,800	TBM-1800
1,950	TBM-1950
2,000	TBM-2000
2,100	TBM-2100
2,150	TBM-2150
2,200	TBM-2200
2,250	TBM-2250
2,400	TBM-2400
2,550	TBM-2550

Table 2 Tone Burst Oscillator Module List

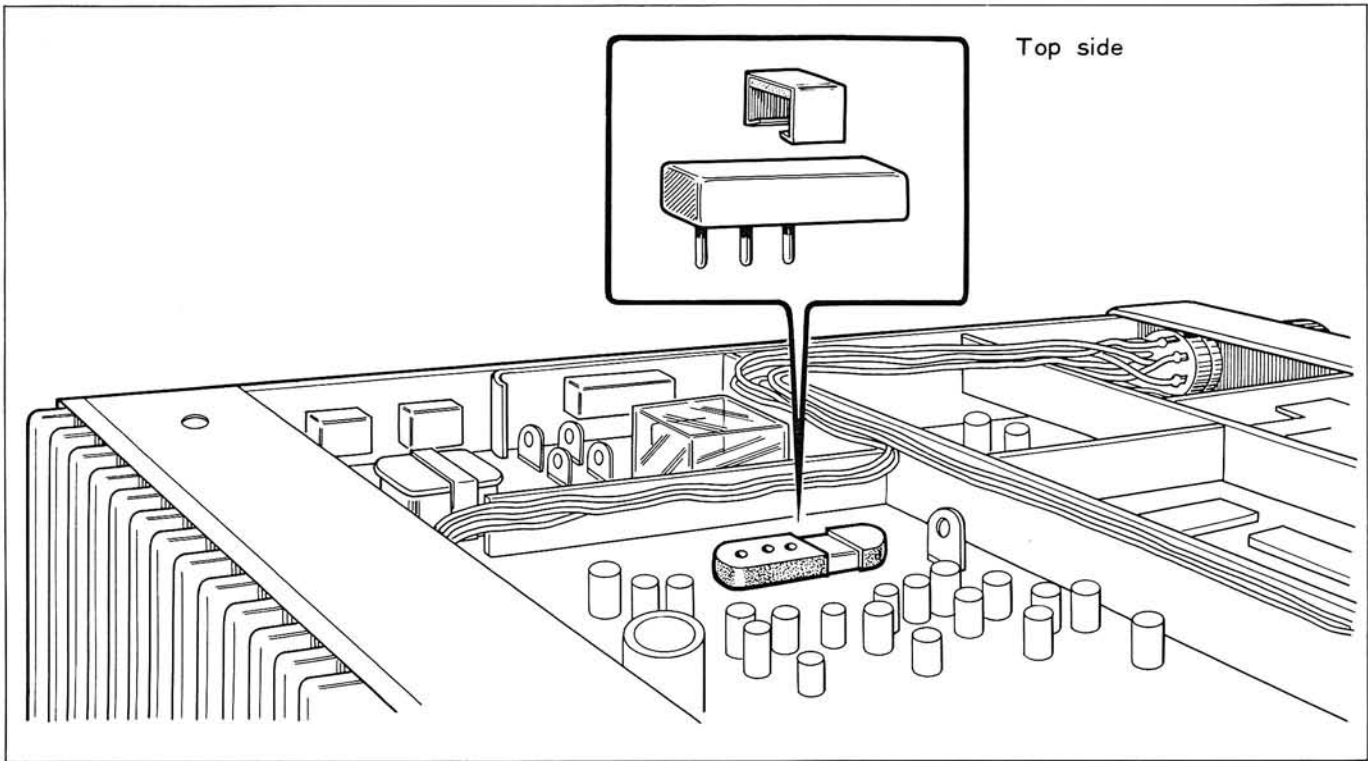

Fig. 10 How to Install the Tone Oscillator Module

4.6 DESCRIPTION OF UNLOCK INDICATOR

The TR-7400A has a protection circuit which prevents it from radiating undesirable signals should the phase-locked loop (PLL), which is employed for the frequency synthesis, be unlocked. If the protection circuit operates, the Unlock Indicator ⑯ located at the center of the front panel lights red and stops the local oscillator, thus shutting the TR-7400A receive and transmit operation down.

However, you should note that the PLL will work normally even if the Unlock Indicator ⑯ lights red momentarily in the following cases:

1. The POWER ON Switch ① is depressed and released.
2. The MHz, 100 kHz and 10 kHz Selector Switches (⑫, ⑬, ⑭) are turned, or the 5 kHz Offset Switch depressed.
3. The microphone button is depressed or released when the TX OFFSET Switch ⑰ is positioned at +600 or -600 for repeater operation.
4. The TX OFFSET Switch ⑰ is shifted to +600 or -600 during transmit.

4.7 HOW TO USE THE TONE PAD

The TR-7400A has a tone pad input for "Auto patch" operation. If you use a tone pad on the market, connect the supplied miniature plug from your tone pad.

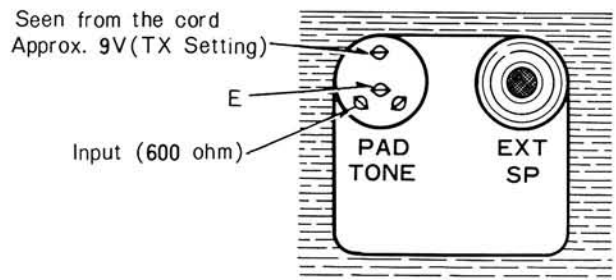

(a) TONE PAD Connector

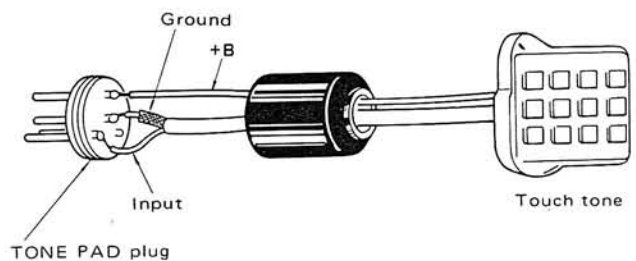

(b) Connection of Touch Tone

SECTION 5. ADDITIONAL INFORMATION

If your transceiver fails to work, contact the authorized dealer from which you purchased it for quick, reliable repair. All adjustable trimmers and coils in your transceiver were preset at the factory and should only be readjusted by a qualified technician with proper test equipment.

HOW THE TX FINAL TRANSISTORS ARE PROTECTED

The TX unit final transistor protection provided in the TR-7400A is done by sampling the reflected power. As the

reflected power is increased (higher SWR) the voltage to the driver transistors is reduced.

If the transmit signal does not reach an expected distant point, check the antenna system. That is, whether the antenna and coaxial cable is well connected or not. If it is open, or the SWR is infinite, the transmit signal is on the air, but the protection circuit operates such that the driver transistor collector voltage is lowered to decrease the level of the signal input to the final transistors, which in turn reduces collector loss, thus protecting the final transistors.

TR-7400A SCHEMATIC DIAGRAM

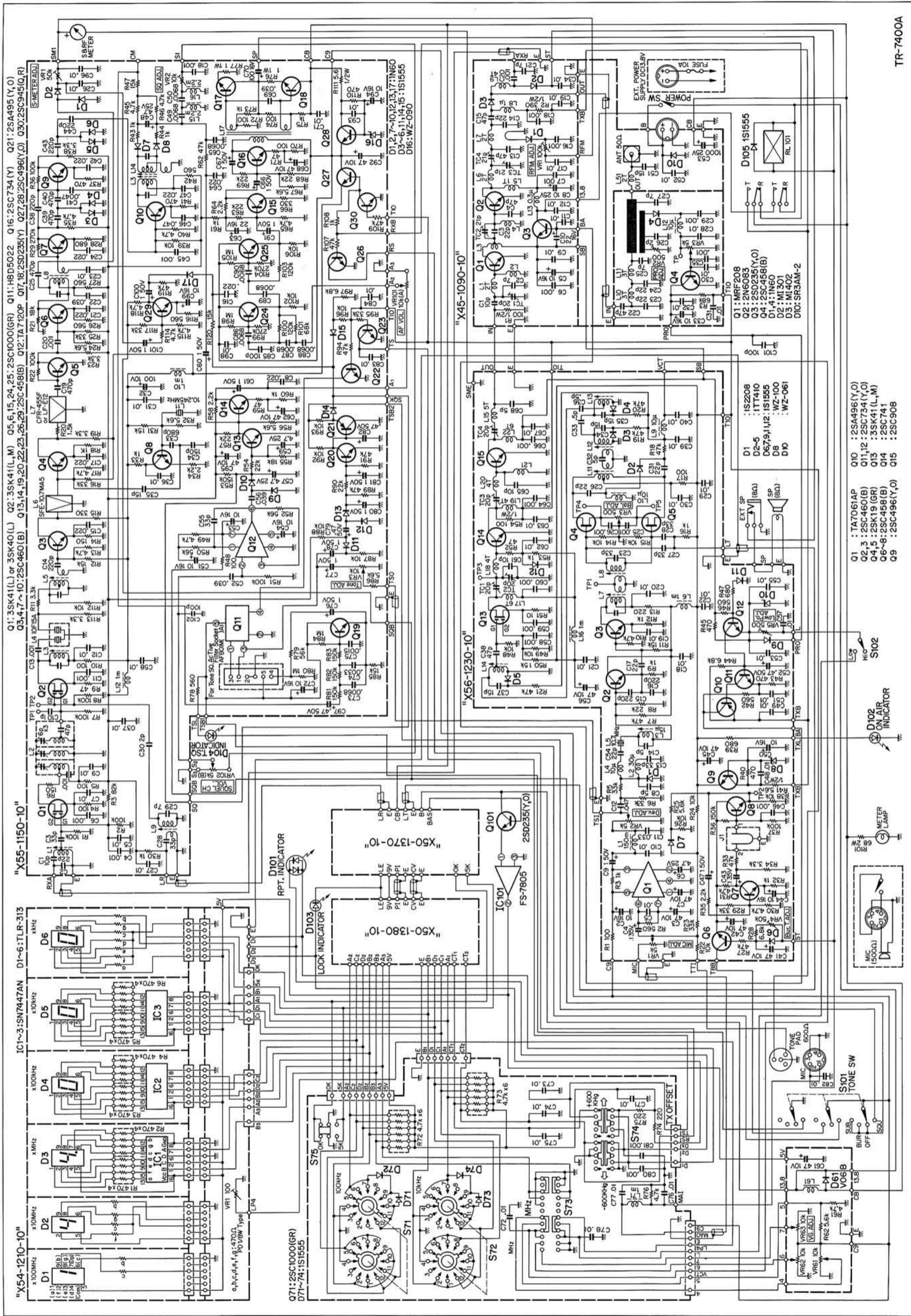

TOP & BOTTOM VIEW OF THE TR-7400A

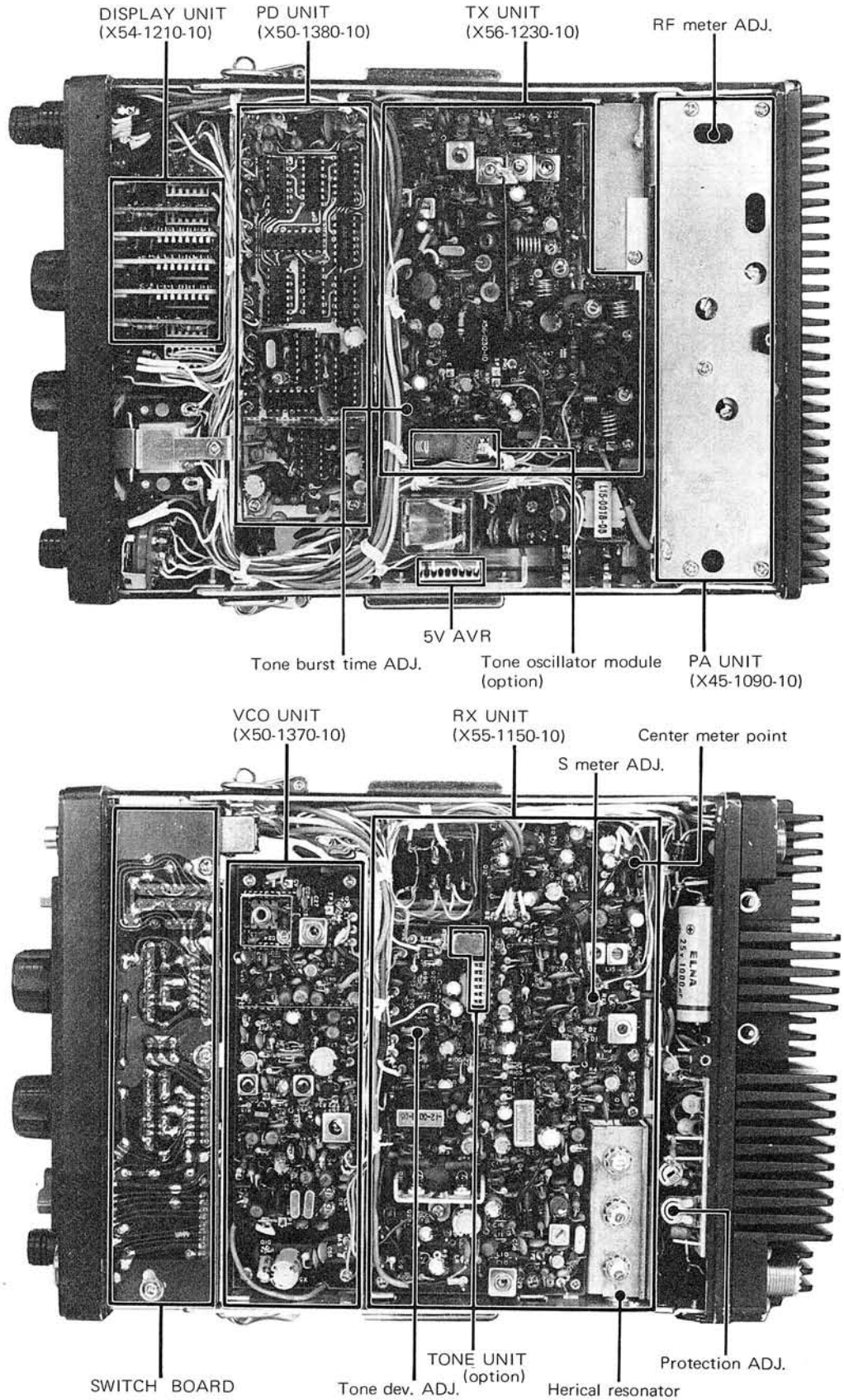



A product of
TRIO-KENWOOD CORPORATION

6-17, 3-chome, Aobadai, Meguro-ku, Tokyo 153, Japan

© 7469 PRINTED IN JAPAN B50-2515-00 (T)

