

Most - Often - Needed

1948

RADIO
DIAGRAMS

and Servicing Information

Compiled by

M. N. BEITMAN



SUPREME PUBLICATIONS
CHICAGO

MANUAL OF 1948 MOST-OFTEN-NEEDED RADIO DIAGRAMS

FOREWORD

Volume 8 of the series "Most-Often-Needed Radio Diagrams" is an important addition to your library of practical radio books. The 1948 radio models will be released in very large quantity and all popular sets included in this volume will aid you in turning out better work in less time.

As in the case of earlier volumes, data included have been selected with great care so that it will prove most useful to you. Supplementary material, detailed parts lists, alignment information, voltage values, dial stringing sketches, parts layout photographs, stage gain, and other helpful facts have been incorporated where such additional material is really needed.

Although the cost of printing has risen out of all proportion to logic, we insist on using the same high quality paper and workmanship, and have decided to sell this new volume at the customary low price of only \$2.00. Perhaps by cutting our profit margin to a bare minimum, is a good way to express our thanks for the patronage given to us by radio servicemen during our fourteen years in business.

Our sincere thanks also is extended to the radio manufacturers who have cooperated with us in presenting service material on their radio receivers. Factory supplied information is best and we try not to change it except to conform to the requirements of this manual.

M. N. BEITMAN

December 1, 1947

Copyrighted 1947, Supreme Publications, Chicago

All rights reserved, including the right to reproduce or quote the contents of this book, or any portion thereof, in any form.

MANUAL OF 1948 MOST-OFTEN-NEEDED RADIO DIAGRAMS

INDEX

Always use this complete Index to find description of the radio you are servicing.

Admiral Radio		Arvin		Emerson Radio	
4B1	6	RE-231	124	511	27
5H1	7	RE-237	127	512	28
5K1	8	552AN	124	514	29
5N1	9	552N	124	515	28
UL5K1	8	555	124	516	28
6L1	10	555A	124	517	27
7C1	11	665	126	525	31
7C63	11	6640	125	530	28
7P32	7			531	30
7P33	7	Bendix Radio		532	30
7P34	7	416A	15	533	30
7RT41	10	R526M	17	534	29
7RT42	10	697A	16	536A	32
7RT43	10			540A	26
7T01	9	Buick		541	27
7T04	9	980744	174-175	543	33-34
7T06	6	980745	174-175	544	33-34
7T10	8			547A	35
7T12	6	Clarion		548	37
7T14	8	see Warwick Mfg.		549	37
7T15	8			550	28
		Coronado		551A	32
Air King		see Gamble-Skogmo		552	31
470-1	12			553A	32
		Crosley		558	36
Airline		56TD	19	560	39
see Montgomery		56TN	20	1002	38
		56TQ	21	1003	38
Allied Radio		56TY	22	120006	28
5B175	12	56TZ	21	120007	29
5B176	12	57TK	23	120010	27
5C175	12	57TL	23	120016	39
5C176	12	57TQ	21	120036	32
6A-122	14	58TC	18	120037	31
6A-127	13	58TW	18	120040	30
6B-122	14			120042A	26
6B-127	13	Delco		120046	33
6C-122	14	see United Motors		120050A	35
6C-127	13			120051	37
		Echophone		120052	34
Arvin		EC-306	66	120056	28
140P	123	EX-306	66	120058	36
150-TC	128			129003	38
151-TC	128	Electronic Corp.			
182TFM	127	101	25		
RE-202	124	102W	25		
RE-206-2	125	104	25		
RE-209	123	106	25		
RE-228	128	108	24		
RE-229	126	133	25		

Continued on page 4

MANUAL OF 1948 MOST-OFTEN-NEEDED RADIO DIAGRAMS

Espey Mfg. Co.

97-A	40
6547	40
10536A	41
20516A	40
20626-A	40

Fada Radio

P-82	42
P-100	42
711	43
740	43

Farnsworth

GK-100	44
GK-102,GK-103	44
GK-104	44
C-170	44
C-194	44
C-196	45
C-201	44
C-216	44
EF-451	45

Galvin Mfg. Co. see Motorola

Gamble-Skogmo

43-5005	46
43-8177	47
43-8178	47
43-8179	47
43-8190	48
43-8201	49
43-8353	50
43-8354	50

Garod Radio

4A-1	52
4A-2	52
5A1	52
5AP1-Y	51
5D-5	51
11FMP	53

General Electric

15	60
41	54-55
42	54-55
43	54-55
44	54-55
45	54-55
YRB 79-1	56
YRB 79-2	56

General Electric

YRB 83-1	56
140	57
180	58
254	59-60
280	61

General Television

23A6	62
------	----

Gilfillan

56	64
66B	62
66PM	64

Goodrich (B.F.) Co.

R662	63
R662N	63

Hallicrafters Co.

S-38	65
EC-306	66
EX-306	66

Hamilton Radio

6-507	67
6-608	68
7-526	69

Hoffman Radio Corp.

100	70
100S	70
110S	71
113	72
118	73
119	74
A202	74
A300	70
A309	74
B400	73
B502	72
A700	71

Howard Radio

902-A	79
906-S	75-76
909-M	77-78

Knight

see Allied Radio

Majestic Radio

5A445	80
5A445R	80
5AK711	81
5AK731	81-82
5AK780	81-82
5B01A	81

Majestic Radio

5B05A	81-82
7JK777R	83
7P420	85
8S473	84
4506	80
4705	85
4708R	83
4810	84

Mantola

R662	63
R662N	63

Masco

Phonograph	86
------------	----

John Meck Indust.

PM-5C5-P	87
RC-5C5-P	87
6A7	88

Midwest Radio

16	89
816	89

Montgomery Ward

74BR-1053A	90
74BR-1055A	90
74BR-2001A	91
74WG-1054A	92
74WG-1056A	93
74WG-1509A	94
74WG-1510A	94
74WG-1802A	95
74WG-1803A	95
74WG-1804D	94
74WG-1805A	94
74WG-2004	95
74WG-2010B	100
74WG-2504C	96-97
74WG-2704C	96
74WG-2705A	102
74WG-2709A	98-99

Motorola, Inc.

CT6	113-115
HS-22	111-112
HS-26	111-112
47B11	106
HS-52	111-112
ST-56	116-121
57X11	107-108
57X12	107-108
HS-59	109-110
HS-60	107-108
65F21	111-112
67F61BN	104-105

MANUAL OF 1948 MOST-OFTEN-NEEDED RADIO DIAGRAMS

Motorola, Inc.		R.C.A. Mfg. Co.		Sentinel Radio		Trav-ler Radio	
67L11	109-110	CV-42	143	293-CT	157-158	501	172
HS-69	104-105	54B5	142	309-I	156	5019	171
85F21	111-112	63E	141	309-N	156	5028	172
85K21	111-112	63EM	141	309-R	156	5051	171
Chevrolet	113-115	65BR9	145	309-W	156	7004	172
Tuner	116-121	65F	143				
		66X11	144	Silver (McMurdo) Co.		Truetone	
National Union		66X12	144	906	159	see Western Auto	
G-619	122	66X13	144			United Motors	
		66X14	144	Silvertone		R-1236	173
Noblitt-Sparks		66X15	144	see Sears, Roebuck		R-1237	173
140P	123	68R1	146-147			R-1238	173
150-TC	128	68R2	146-147	Simpson (Mark) Mfg.		980744	174-175
151-TC	128	68R3	146-147	Phonograph	86	980745	174-175
182TFM	127	68R4	146-147				
RE-202	124	RS-127	141	Sonora Radio			
RE-206-2	125	RC-608	146-147	WA-243	161	Warwick Mfg. Co.	
RE-209	123	RS-1000	143	WA-244	161	C110	176
RE-228	128	RC-1004E	143	WAU-243	161	11011	176
RE-229	126	RC-1045	145	WAU-244	161		
RE-231	124	RC-1046	144	WD-233	162	Western Auto	
RE-237	127	RC-1046A	144	WD-249	162	D-1747	177-178
552AN	124	RC-1046B	144	WDU-233	162	D-1748	177-178
552N	124	RC-1047	142	WDU-249	162	D-2624	179
585	124			WGF-241	160	D-2630	179
555A	124	Regal Electronics		WGF-242	160	D-2634	180
665	126	1049	148	WGFU-241	160	D-2718	179
6640	125			WGFU-242	160	D-2745	182
		Sears, Roebuck				Westinghouse Elec.	
Olympic Radio		6285	149	Sparks-Withington		H-133	183
6-507	67	6285A	149	see Spanton		H-148	184
6-608	68	7020	152			H-157	185
7-526	69	7021	152	Spanton			
		7086	151	5-07PA	164	Wilcox-Gay Corp.	
Packard-Bell		7103	151	5-16	163	6B45B	181
5DA	129	7165	152	6-06	166	6B45M	181
471	131	7166	152	6-26	165	6B45W	181
673	130	7210	154	6-26-PA	165		
		8000	150			Zenith Radio Corp.	
Philco Radio		8144	153	Stewart-Warner		4C21	187
UN-6-400	133	8150	153	A41T1	167	4C54	188-189
46-250	132	101.666A	149	A51T1	168	4K040	198-199
46-350	134	101.666-1B	149	A51T2	168	4K040G	188-189
46-427	135	101.807,-A	152	A51T3	168	5C40	190-191
46-1226	136	101.820	154	A51T4	168	5C40Z	190-191
250	132	101.823,-1,-A	152	A61CR1	169	5C51	186
350	134	109.634	153	A61CR2	169	5G003	190-191
427	135	110.466	151	A61CR3	169	5G003Z	190-191
1226	136	110.466-1	151	A61CR4	169	5G036	186
		132.838	150	9020-A, to-D	168	6C50	192
Pilot Radio		431.199	153	9032-A	167	6C038	192
T-521	137-138	Sentinel Radio		9034-C, to-F	169	11C21Z Change	189
T-570	138	1U-293-CT	157-158	Templetone Radio		S-12600	187
T-601	140	286P	155	E-510toE-519	170		
T-741	139	286PR	155	G-513	170		
Pilotuner	140			G-515	170		

MANUAL OF 1948 MOST-OFTEN-NEEDED RADIO DIAGRAMS

Admiral

CHASSIS 4 B 1
MODELS 7T06, 7T12

TUBE AND TRIMMER LOCATION

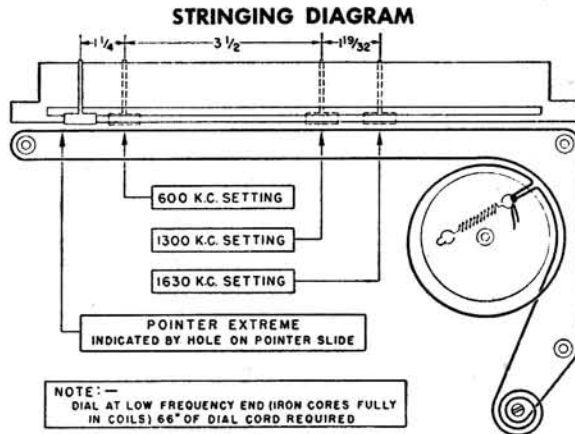
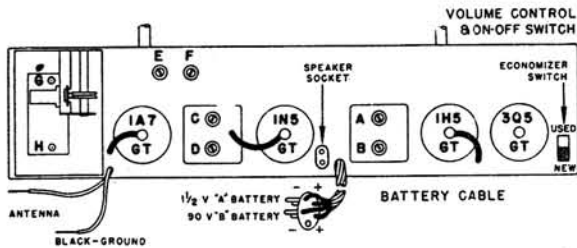

NOTE: —
DIAL AT LOW FREQUENCY END (IRON CORES FULLY
IN COILS) 66" OF DIAL CORD REQUIRED

VOLTAGE CHART

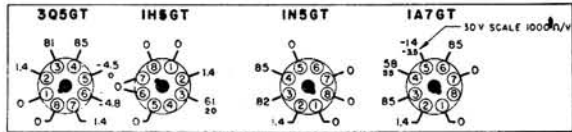

BACK OF CHASSIS

VOLTAGE DATA

All readings made between tube socket terminals and chassis. Voltages indicated have been obtained using a Vacuum Tube Voltmeter. A second voltage reading is shown with a 1000 ohm-per-volt meter, when use of this instrument would result in appreciably lower readings. Measured with a fresh battery, volume control full on, dial at the high frequency end, no signal.

CONDENSERS

Symbol	Description	Part No.
C1	.01 mfd. 400 Volts	64B 1-25
C2	.0008 mfd., Mica	65B 5-31
C3	Trimmer, Antenna	66A 9-1
C4	Trimmer, Oscillator	
C5	.0001 mfd.	65B 7-17
C6	.0008 mfd., Mica	65B 5-31
C7	.01 mfd., 400 Volts	64B 1-25
C8	.002 mfd., 600 Volts	64B 1-14
C9	4. mfd., 150 Volts (Elect.)	67A 4-2
C10	.05 mfd., 200 Volts	64B 1-32
C11	.0025 mfd., Mica	65B 7-22
C12	.00025 mfd., Mica	65B 7-22
C13	.01 mfd., 400 Volts	64B 1-25
C14	.01 mfd., 400 Volts	64B 1-25
C15	.005 mfd., 600 Volts	64B 1-12
C16	.01 mfd., 400 Volts	64B 1-25
C17	.01 mfd., 400 Volts	64B 1-25

(C17 omitted in early models)

Occasionally audio oscillation may occur in the 4B1 chassis with the volume control in an intermediate position. Should you encounter this trouble, reverse the leads of the primary of the output transformer or ground the speaker frame to the chassis. The speaker leads and grid lead of the 1H5 should be kept as far as possible from the 3Q5 output tube.

RESISTORS

Symbol	Description	Part No.
R1	15,000 ohm 1/2 Watt	60B 8-153
R2	470,000 ohm 1/4 Watt	60B 2-474
R3	220,000 ohm 1/2 Watt	60B 8-224
R4	33,000 ohm 1/2 Watt	60B 8-333
R5, R8	4,700,000 ohm 1/4 Watt	60B 2-475
R6	2,200,000 ohm 1/4 Watt	60B 2-225
R7	1 meg. Vol. Control	75B 1-1
R9, R10	1,000,000 ohm 1/4 Watt	60B 2-105
R11	390 ohm 1/4 Watt	60B 2-391
R12	75 ohm 1/2 Watt (wire)	61A 2-1
R13	2200 ohm 1/4 Watt	60B 2-222

TRANSFORMERS and COILS

Symbol	Description	Part No.
L1	Antenna Coil	AC105-1
L2	Oscillator Coil	A1020
L3	1st I.F. Transformer	72B 5
L4	2nd I.F. Transformer	72B 6
L5	Choke Coil (RF)	AB103-1
T1	Output Transformer	98A 5

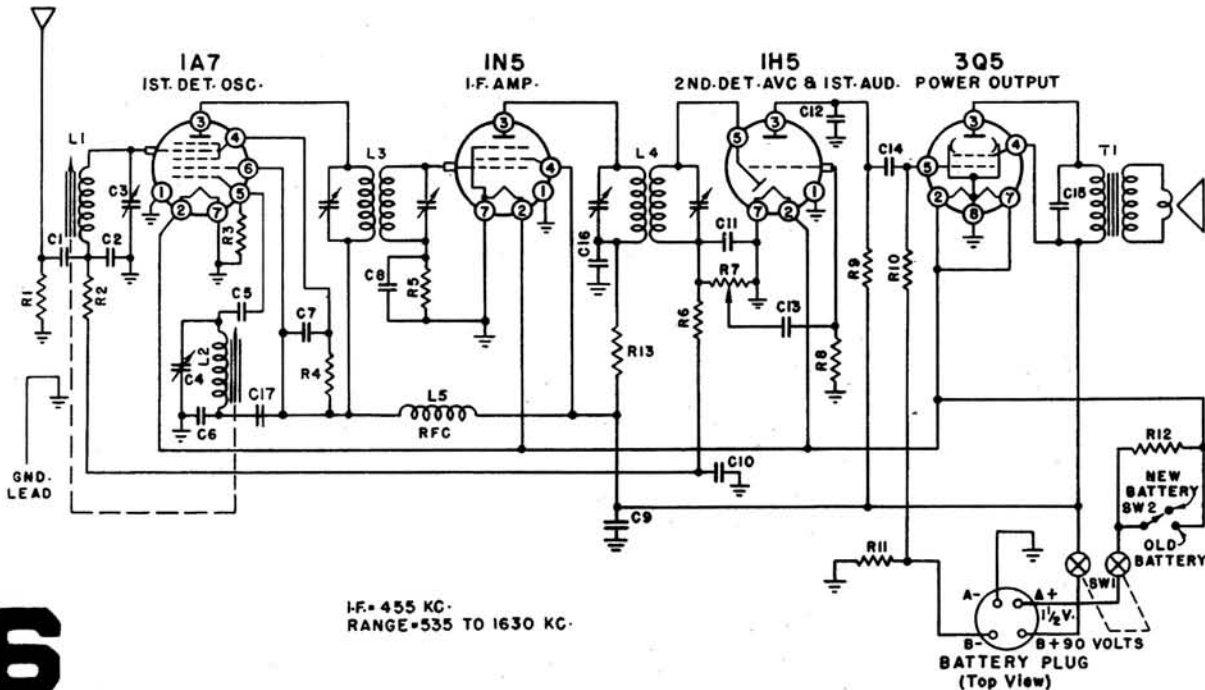

I.F. = 455 KC.
RANGE = 535 TO 1630 KC.

MANUAL OF 1948 MOST-OFTEN-NEEDED RADIO DIAGRAMS

CHASSIS 5 H 1

MODELS 7P32, 7P33, 7P34

Admiral

ALIGNMENT PROCEDURE

1. Disconnect Loop Antenna leads from clips on set and remove chassis from cabinet.
2. Make alignment using a battery whenever possible.
3. Connect a fresh battery to the set.

IMPORTANT: Check dial drum position on shaft. Tuner arm should just complete downward travel when gang is fully meshed. At this point, tuner arm should be on short flat part of cam. Check pointer. It should be at last dial scale mark just below 550 K.C. when gang is fully meshed. If not, move pointer on dial cord.

Step	Dummy Antenna Used in Series with Signal Generator	Connect High Side Signal Generator to	Signal Generator Frequency	Receiver Gang Setting	Trimmer Designation and Description	Type of Adjustment
(1)	.00025 Mfd. when using A.C. .1 Mfd. when using Battery	Grid of 1R5 (Pin 6)	455 K.C.	Any point where it does not affect Signal	2nd I.F. 1st I.F.	Maximum Deflection Then repeat
(2)	.00025 Mfd. when using A.C. .1 Mfd. when using Battery	Stator lug of rear variable condenser section	1620 K.C.	Tuning Gang Wide Open	Oscillator Trimmer	Maximum Deflection
(3)	.00025 Mfd. when using A.C. .1 Mfd. when using Battery	Stator lug of rear variable condenser section	1400 K.C.	Tune in Generator Signal	R.F. Slug	Maximum Deflection
(4)	Replace Set in Cabinet					
(5)	.00025 Mfd.	Antenna and Ground Leads	1400 K.C.	Tune in Generator Signal	Antenna Trimmer	Maximum Deflection

RESISTORS

Symbol	Description	Part No.
R1	2.2 Megohms, 1/4 Watt	60B 3-225
R2	1 Megohm, 1/4 Watt	60B 3-105
R3	100,000 Ohms, 1/4 Watt	60B 3-104
R4	18,000 Ohms, 1/3 Watt	60B 2-183
R5	3.3 Megohms, 1/4 Watt	60B 2-335
R6	10 Megohms, 1/4 Watt	60B 3-106
R7	1 Megohm Volume Control and Switch SW2 (DPST)	75B 1-18
R8	4.7 Megohms, 1/4 Watt	60B 2-475
R9	470,000 Ohms, 1/4 Watt	60B 3-474
R10	10,000 Ohms, 1/4 Watt	60B 3-103
R11	2.2 Megohms, 1/4 Watt	60B 3-225
R12	47 Ohms, 1 Watt	60B 14-470
R13	2700 Ohms, 1 Watt	60B 14-272

R14	2600 Ohms, 5 Watt	61A 6-1
R15	1500 Ohms, 1/4 Watt	60B 2-152
R16	820 Ohms, 1/4 Watt	60B 2-821
R17	220 Ohms, 1/4 Watt	60B 2-221
R18	150 Ohms, 1/4 Watt	60B 2-151

CONDENSERS

C1	250 Mmfd., Mica	65B 7-22
C2	25 Mfd., 200 Volts, Paper	64B 1-28
C3	420 Mmfd., Mica	65B 1-13
C4	250 Mmfd., Mica	65B 7-22
C5	.01 Mfd., 400 Volts, Paper	64B 1-25
C6	100 Mmfd., Mica	65B 7-17
C7	15 Mmfd., Ceramic	65B 6-18
C8	.01 Mfd., 400 Volts, Paper	64B 1-25

C9	.01 Mfd., 400 Volts, Paper	64B 1-25
C10	250 Mmfd., Mica	65B 7-22
C11	.01 Mfd., 400 Volts, Paper	64B 1-25
C12	100 Mmfd., Mica	65B 7-17
C13	.01 Mfd., 400 Volts, Paper	64B 1-25
C14	4 Mfd., 150 Volts, Electrolytic	67A 4-2
C15	.002 Mfd., 600 Volts, Paper	64B 1-14
C16	.18 Mfd., 200 Volts, Paper	64A 2-2
C17a	50 Mfd., 150 Volts, Elect.	
C17b	20 Mfd., 150 Volts, Elect.	
C17c	200 Mfd., 25 Volts, Elect.	67C 7-5
C17d	20 Mfd., 150 Volts, Elect.	
C18	.05 Mfd., 400 Volts, Paper	64B 1-22
C19a	0 to 420 Mmfd., Gang	
C19b	0 to 162 Mmfd., Gang	68B 6
C20	10 Mmfd., Ceramic	65B 6-24

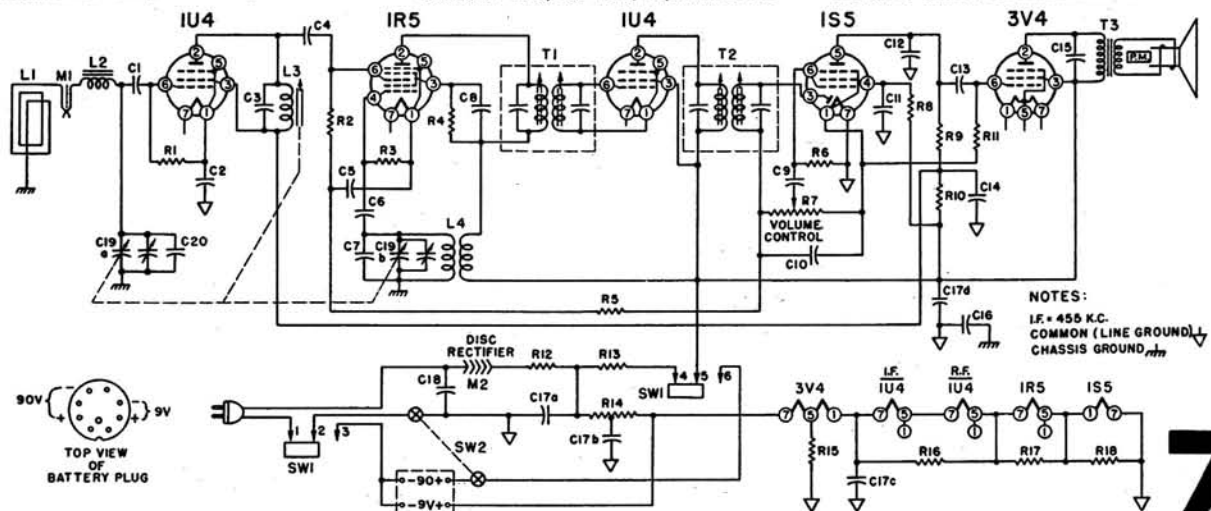

MANUAL OF 1948 MOST-OFTEN-NEEDED RADIO DIAGRAMS

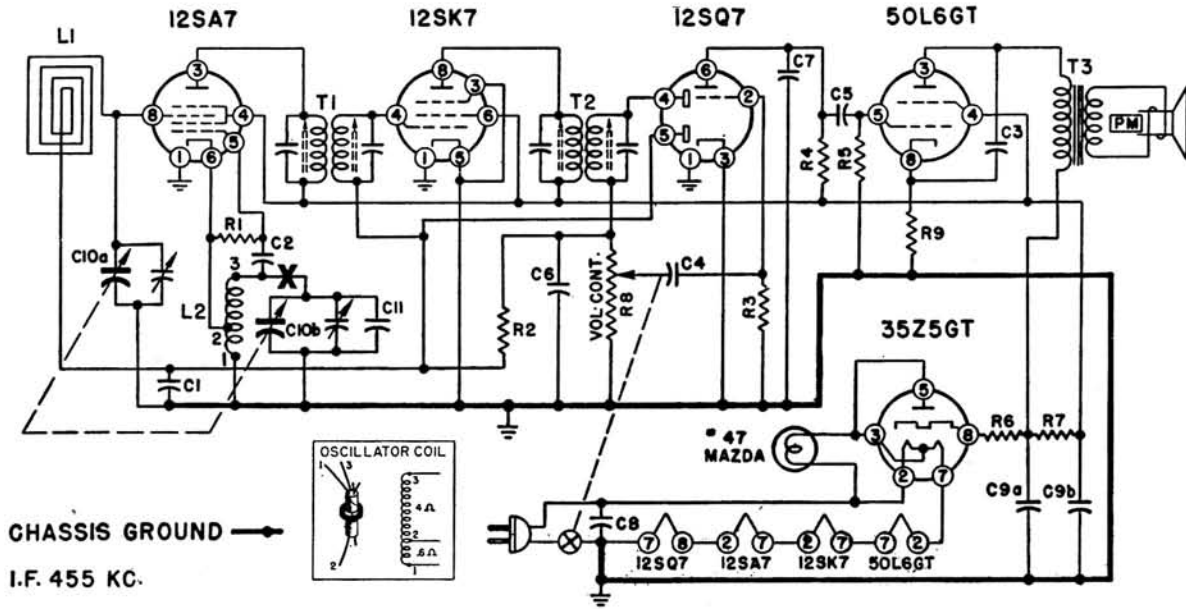

- UL5K1** { 1. .05 mfd. condenser added at point "X" in oscillator circuit.
 2. B minus is isolated from chassis by 150,000 ohm resistor and .18 mfd. condenser in parallel.
 3. Gang condenser grounded to chassis and not connected to B minus as in above circuit.

Admiral

CHASSIS 5 K 1
 MODELS 7T10, 7T14, 7T15

RESISTORS

Symbol	Description	Part No.
R1	22,000 Ohms, 1/2 Watt	608 8-223
R2	1 Megohm, 1/2 Watt	608 8-105
R3	4.7 Megohms, 1/2 Watt	608 8-475
R4	470,000 Ohms, 1/2 Watt	608 8-474
R5	470,000 Ohms, 1/2 Watt	608 8-474
R6	33 Ohms, 1 Watt	608 28-3
R7	1000 Ohms, 1 Watt	608 28-2
R8	1 Megohm Volume Control and Switch	75B 1-16
R9	150 Ohms, 1/2 Watt	608 8-151

CONDENSERS

C1	.1 mfd., 200 Volts, Paper	64B 1-30
C2	.50 mmfd., ±20%, Ceramic	65B 6-4
C3	.02 mfd., 400 Volts, Paper	64B 1-24
C4	.01 mfd., 400 Volts, Paper	64B 1-25
C5	.01 mfd., 400 Volts, Paper	64B 1-25
C6	.250 mmfd., ±20%, Ceramic	65B 6-5
C7	.500 mmfd., ±20%, Ceramic	65B 6-6
C8	.05 mfd., 400 Volts, Paper	64B 1-22
C9a	.50 mmfd., 150 Volts	Elec. 67A 10
C9b	.30 mmfd., 150 Volts	Elec. 67A 10
C10a	Gang, 0 to 420 mmfd.	A1460
C10b	Gang, 0 to 162 mmfd.	A1460
C11	.20 mmfd., ±20%, Ceramic	65B 6-26

Connect Signal Generator to—	Dummy Antenna Between Radio and Generator	Set Generator Frequency to—	Set Receiver Dial Frequency to—	Adjust Following Trimmers	Type of Adjustment
Tuning Condenser Antenna Stator	250 mmfd. Condenser	455 K.C.	High frequency end of Dial	A-B—2nd I. F. C-D—1st I. F. (See note below)	Adjust to maximum Output
Tuning Condenser Antenna Stator	250 mmfd. Condenser	1630 K.C.	High frequency end of Dial	E—Osc.	Adjust to maximum Output
Loop radiator (or place lead from generator close to loop of set to obtain adequate signal).	No actual connection between set and generator.	1400 K.C.	Tune in generator signal	F—Ant.	Adjust to maximum Output

Note: In some sets, the B and D adjustments must be made from the underside of the chassis.

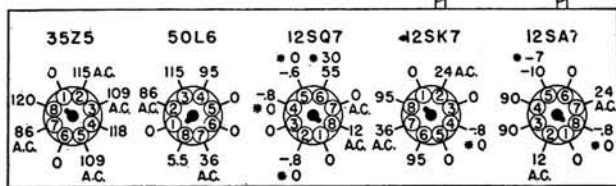

8

• Voltages measured with a vacuum-tube voltmeter. A second voltage reading (marked with an asterisk *) indicates readings made with a 1000 ohm-per-volt meter.

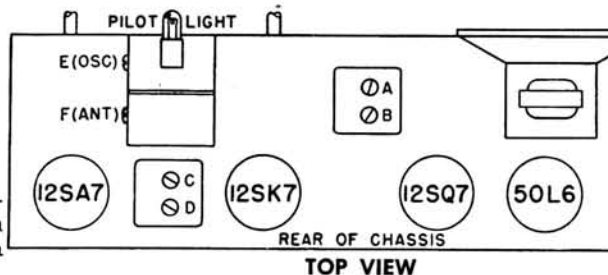

MANUAL OF 1948 MOST-OFTEN-NEEDED RADIO DIAGRAMS

Admiral

CHASSIS 5 N 1
MODELS 7T01, 7T04

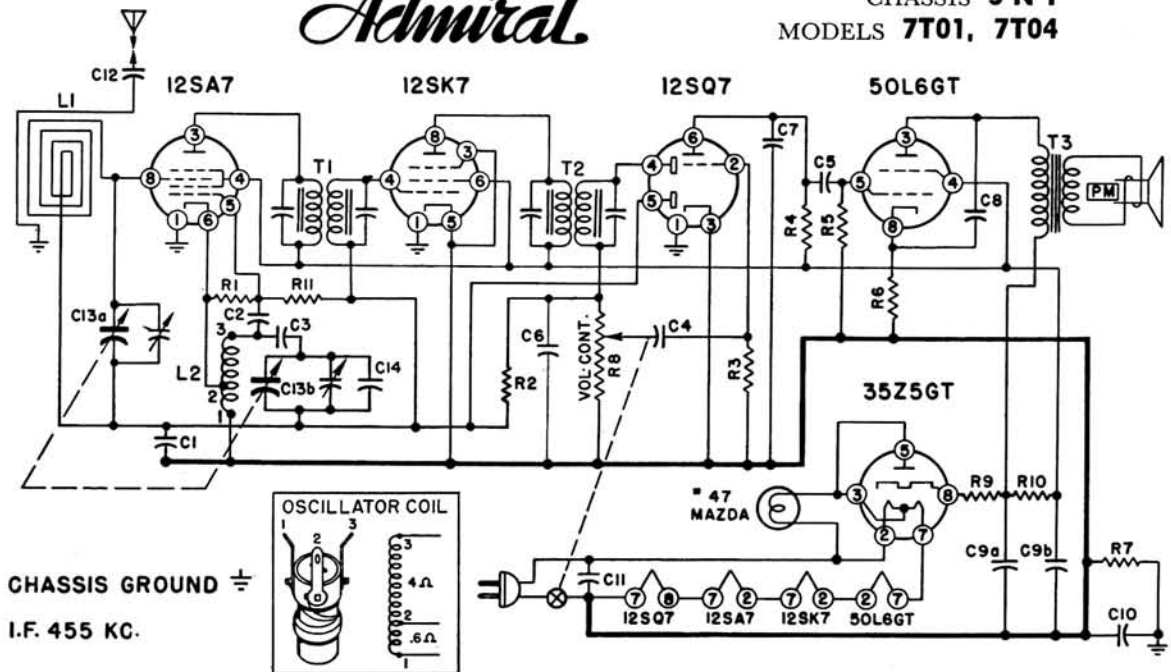

CHASSIS GROUND \equiv
I.F. 455 KC.

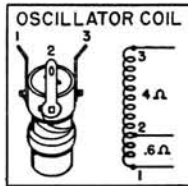

NOTE: Condenser C3 used only on models having the suffix "UL".

DIAL CORD STRINGING & POINTER SETTING

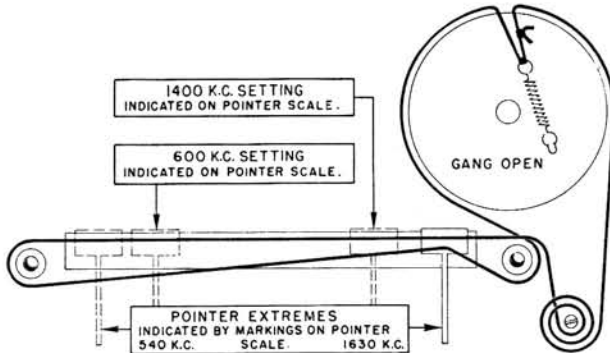

VOLTAGE CHART

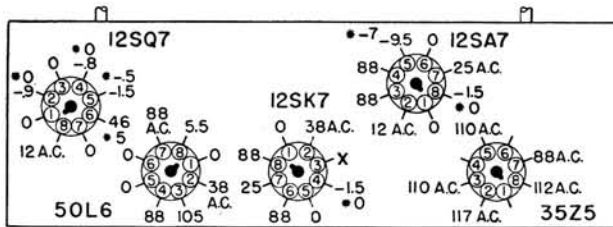

- All readings made between tube socket terminals and pin 3 of 12SK7 (marked "X" on Voltage Chart).
- Voltages measured on a 117 Volt A.C. line.
- Dial turned to low frequency end, no signal.
- Voltages measured with a vacuum-tube voltmeter. A second voltage reading (marked with an asterisk *) indicates readings made with a 1000 ohm-per-volt meter when use of this instrument would result in appreciably lower readings.

RESISTORS

Symbol	Description	Part No.
R1	22,000 Ohms, 1/2 Watt	608 8-223
R2	1 Megohm, 1/2 Watt	608 8-105
R3	4.7 Megohms, 1/2 Watt	608 8-475
R4	470,000 Ohms, 1/2 Watt	608 8-474
R5	470,000 Ohms, 1/2 Watt	608 8-474
R6	150 Ohms, 1/2 Watt	608 8-151
R7	150,000 Ohms, 1/2 Watt	608 8-154
R8	1 Megohm Volume Control & Switch	75B 1-6
R9	33 Ohms, 1 Watt	608 28-3
R10	1,000 Ohms, 1 Watt	608 28-2
R11	10 Megohms, 1/4 Watt	608 2-106

CONDENSERS

C1	.1 mfd., 200 Volts, Paper	64B 1-30
C2	50 mmfd., Ceramic	65B 6-4
C3	.02 mfd., 400 Volts, Paper	64B 1-24
C4	.01 mfd., 400 Volts, Paper	64B 1-25
C5	.01 mfd., 400 Volts, Paper	64B 1-25
C6	250 mmfd., Ceramic	65B 6-5
C7	500 mmfd., Ceramic	65B 6-6
C8	.02 mfd., 400 Volts, Paper	64B 1-24
C9a	50 mmfd., 150 Volts	Elec. 67A 3
C9b	30 mmfd., 150 Volts	
C10	.1 mfd., 400 Volts, Paper	64B 1-20
C11	.05 mfd., 400 Volts, Paper	64B 1-22
C12	.005 mfd., 600 Volts, Paper	64B 1-12
C13a	Gang, 0 to 420 mmfd.	A1364
C13b	Gang, 0 to 162 mmfd.	
C14	15 mmfd., Ceramic	65B 6-18

COILS, TRANSFORMERS, ETC.

L1	Antenna, Loop (Includes C12)	69B 4
L2	Coil, Oscillator	69A 14
T1	Transformer, 1st I.F.	72B 31
T2	Transformer, 2nd I.F.	72B 32
T3	Transformer, Output	98A 4
	Speaker (5" PM) and Output Transformer	78B 18-2
	(Can also use 78B 18-1)	*

MISCELLANEOUS

Description	Part No.
Button, Snap (for Dial Background)	13A 1-3-47
Cabinet, Black Plastic (7T01E)	34D 1-3 N
Cabinet, Ivory Plastic (7T01C)	34D 1-1 N
Cabinet, Mahogany Plastic (7T01M)	34D 1-2 N

MANUAL OF 1948 MOST-OFTEN-NEEDED RADIO DIAGRAMS

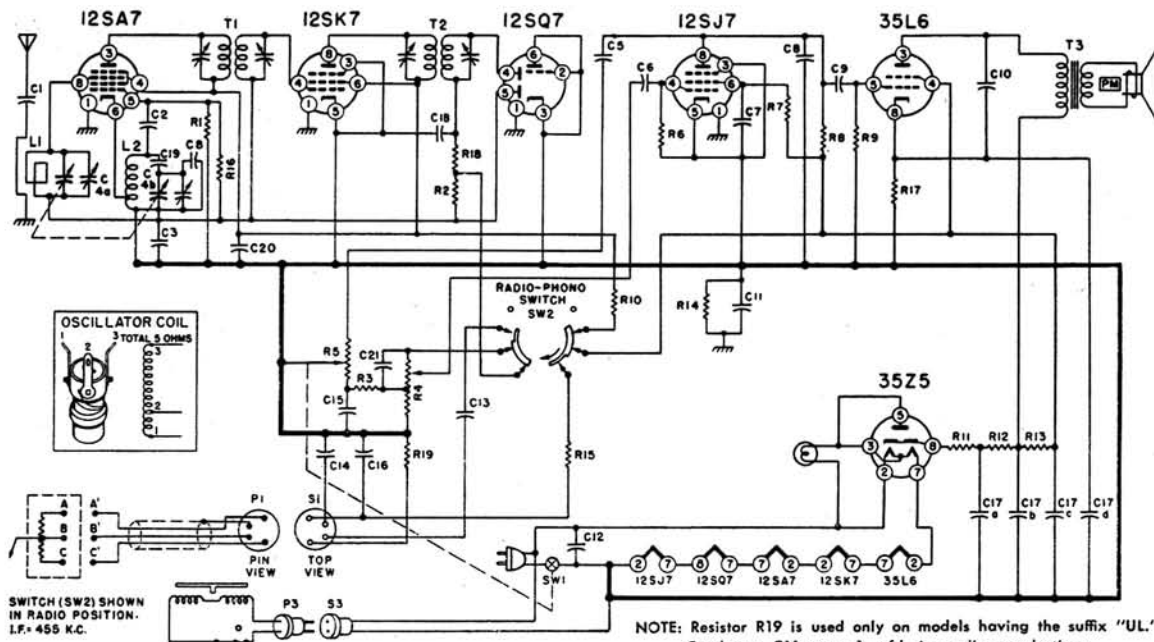

NOTE: Resistor R19 is used only on models having the suffix "UL".
Condenser C11 was .1 mfd. in earlier production.

RESISTORS

Symbol	Description	Part No.
R1	22,000 Ohms, 1/2 Watt	60B 8-223
R2	1 Megohm, 1/2 Watt	60B 8-105
R3	27,000 Ohms, 1/2 Watt	60B 8-273
R4	1 Megohm Volume Control (Tapped at 500,000 ohms)	75B 2-6
R5	2 Megohm Tone Control and Switch SW1	75B 1-12
R6	4.7 Megohms, 1/2 Watt	60B 8-473
R7	1.8 Megohms, 1/2 Watt	60B 8-185
R8	100,000 Ohms, 1/2 Watt	60B 8-104
R9	470,000 Ohms, 1/2 Watt	60B 8-474
R10	100 Ohms, 1/2 Watt	60B 8-101
R11	33 Ohms, 1 Watt	60B 8-23
R12	220 Ohms, 1 Watt	60B 28-3

R13	1,000 Ohms, 1 Watt	60B 28-2
R14	150,000 Ohms, 1/2 Watt	60B 8-154
R15	22,000 Ohms, 1/2 Watt	60B 8-223
R16	10 Megohms, 1/2 Watt	60B 8-106
R17	150 Ohms, 1 Watt	60B 14-151
R18	100,000 Ohms, 1/2 Watt	60B 8-104
R19	33,000 Ohms, 1/2 Watt	60B 8-333

CONDENSERS

C1	.005 mfd., 600 Volts, Paper	64B 1-12
C2	50 mmfd. ±20%, Ceramic	65B 6-4
C3	.1 mfd., 200 Volts, Paper	64B 1-30
C4a	Gang, 0 to 420 mmfd.	68B 5
C4b	Gang, 0 to 162 mmfd.	
C5	.002 mfd., 600 Volts, Paper	64B 1-14
C6	.01 mfd., 400 Volts, Paper	64B 1-25

C7	.05 mfd., 400 Volts, Paper	64B 1-22
C8	15 mmfd. ±20%, Ceramic	65B 6-18
C9	.01 mfd., 400 Volts, Paper	64B 1-25
C10	.03 mfd., 400 Volts, Paper	64B 1-23
C11	.18 mfd., 200 Volts, Paper	64A 2-2
C12	.05 mfd., 400 Volts, Paper	64B 1-22
C13	.001 mfd., 600 Volts, Paper	64B 1-15
C14	.05 mfd., 400 Volts, Paper	64B 1-25
C15	.01 mfd., 400 Volts, Paper	64B 1-24
C16	.1 mfd., 200 Volts, Paper	64B 1-30
C17a	30 mfd., 150 Volts	Elect. 67A 14-1
C17b	30 mfd., 150 Volts	
C17c	20 mfd., 150 Volts	
C17d	20 mfd., 25 Volts	
C18	250 mmfd. ±20%, Ceramic	65B 6-5
C19	.02 mfd., 200 Volts, Paper	64B 1-24
C20	.05 mfd., 400 Volts, Paper	64B 1-22
C21	500 mmfd. ±20%, Ceramic	65B 6-6

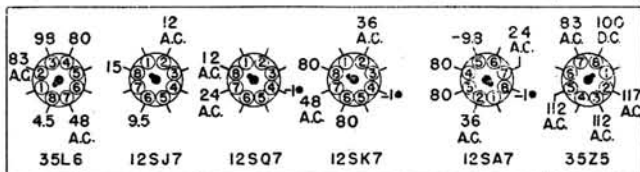

REAR OF CHASSIS

• INDICATES AVG AND WILL VARY WITH SIGNAL

- Measured on a 117 Volt A.C. line.
- Volume control full on.
- Dial tuned to low frequency end, no signal.
- Voltage obtained on Vacuum Tube Voltmeter.

Connect Signal Generator to—	Dummy Antenna Between Radio and Generator	Set Generator Frequency to—	Set Receiver Dial Frequency to—	Adjust Following Trimmers	Type of Adjustment
Tuning Condenser Antenna Stator	250 mmfd. Condenser	455 K.C.	High frequency end of Dial	A-B—2nd I. F. C-D—1st I. F.	Adjust to maximum Output
Tuning Condenser Antenna Stator	250 mmfd. Condenser	1630 K.C.	High frequency end of Dial	E—Osc.	Adjust to maximum Output
Loop radiator (or place lead from generator close to loop of set to obtain adequate signal)	No actual connec- tion between set and generator.	1400 K.C.	Tune in generator signal	F—Ant. (See Note)	Adjust to maximum Output

Note: Antenna Trimmer "F" must be aligned after chassis and loop are mounted in cabinet.
This adjustment can be made thru the small round hole located in the rear of the cabinet.

10

Admiral

CHASSIS 6L1
MODELS 7RT41, 7RT42, 7RT43

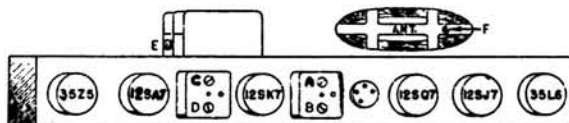

MANUAL OF 1948 MOST-OFTEN-NEEDED RADIO DIAGRAMS

Admiral

CHASSIS 7C1
MODEL 7C63

C13.....	.1 mfd., 400 V.D.C., Paper.....	64B 1-20
C14.....	250 mmfd., Mica.....	65B 7-22
C15.....	1000 mmfd., Mica.....	65B 7-33
C16.....	.02 mfd., 400 V.D.C., Paper.....	64B 1-24
C17.....	.01 mfd., 400 V.D.C., Paper.....	64B 1-25
C18.....	.005 mfd., 600 V.D.C., Paper.....	64B 1-12
C19.....	.01 mfd., 600 V.D.C., Paper.....	64B 1-10
C20a.....	30 mfd., 350 V.D.C., Elec.....	67C 6-25
C20b.....	30 mfd., 350 V.D.C., Elec.....	
C20c.....	20 mfd., 25 V.D.C., Elec.....	
C21a.....	3-40 mmfd., Dual Trimmer.....	66A 1-5
C22a.....	3-40 mmfd., Trimmer.....	66B 8-1
C22b.....	3-40 mmfd., Trimmer.....	66B 8-1
C23a.....	3-40 mmfd., Trimmer.....	66B 8-1
C23b.....	3-40 mmfd., Trimmer.....	66B 8-1
C24.....	100 mmfd., Mica.....	65B 7-17
C26.....	1.200 mmfd., Mica.....	65B 5-34
C27.....	.05 mfd., 200 V.D.C., Paper.....	64B 1-32
C28.....	.25 mfd., 200 V.D.C., Paper.....	64B 1-28
C29.....	.1 mfd., 400 V.D.C., Paper.....	64B 1-20
C30.....	.20 mmfd., Mica.....	65B 7-5
C31.....	500 mmfd. ± 20%, Ceramic.....	65B 6-6

R19.....	100,000 Ohms, ½ Watt.....	60B 8-104
R20.....	100,000 Ohms, ½ Watt.....	60B 8-104
R22.....	100 Ohms, ½ Watt.....	60B 8-101
R23.....	100,000 Ohms, 1 Watt.....	60B 14-104
R24.....	47,000 Ohms, ½ Watt.....	60B 8-473
R25.....	470 Ohms, ½ Watt.....	60B 8-471

CONDENSERS

C1.....	1000 mmfd., Mica.....	65B 7-33
C2.....	35 mmfd., Silver Mica 3%.....	65B 1-31
C3.....	25 mmfd., Silver Mica 3%.....	65B 1-28
C4.....	100 mmfd., Mica.....	65B 7-17
C5.....	50 mmfd., Ceramic.....	65B 6-4
C6.....	.05 mfd., 400 V.D.C., Paper.....	64B 1-22
C7.....	65 mmfd., Silver Mica 3%.....	65B 1-27
C8.....	420 mmfd., Silver Mica.....	65B 1-13
C9.....	1000 mmfd., Mica.....	65B 7-33
C10.....	200 mmfd., Mica 2%.....	65B 7-5
C11.....	65 mmfd., Silver Mica 3%.....	65B 1-27
C12.....	200 mmfd., Silver Mica, 2%.....	65B 1-14

SYMBOL	DESCRIPTION	PART NO.
R1.....	12,000 Ohms, 5 Watt.....	61A 1-1
R2.....	2.2 Megohms, Carbon, ½ Watt.....	60B 8-225
R3.....	470,000 Ohms, ½ Watt.....	60B 8-474
R4.....	10,000 Ohms, 2 Watt.....	60B 20-103
R6.....	22,000 Ohms, ½ Watt.....	60B 8-223
R7.....	10 Megohms, ½ Watt.....	60B 8-106
R8.....	1 Megohm, ½ Watt.....	60B 8-105
R9.....	2 Megohms Tone Control.....	75B 1-8
R10.....	27,000 Ohms, ½ Watt.....	60B 8-273
R11.....	1 Megohm Volume Control and Switch SW4	
R12.....	Tapped at 500,000 Ohms.....	75B 2-2
R13.....	470,000 Ohms, ½ Watt.....	60B 8-474
R14.....	3.3 Megohms, ½ Watt.....	60B 8-474
R15.....	390 Ohms, 1 Watt.....	60B 8-335
R16.....	10 Megohms, ½ Watt.....	60B 14-391
R17.....	100 Ohms, ½ Watt.....	60B 8-106
R18.....	220,000 Ohms, ½ Watt.....	60B 8-224

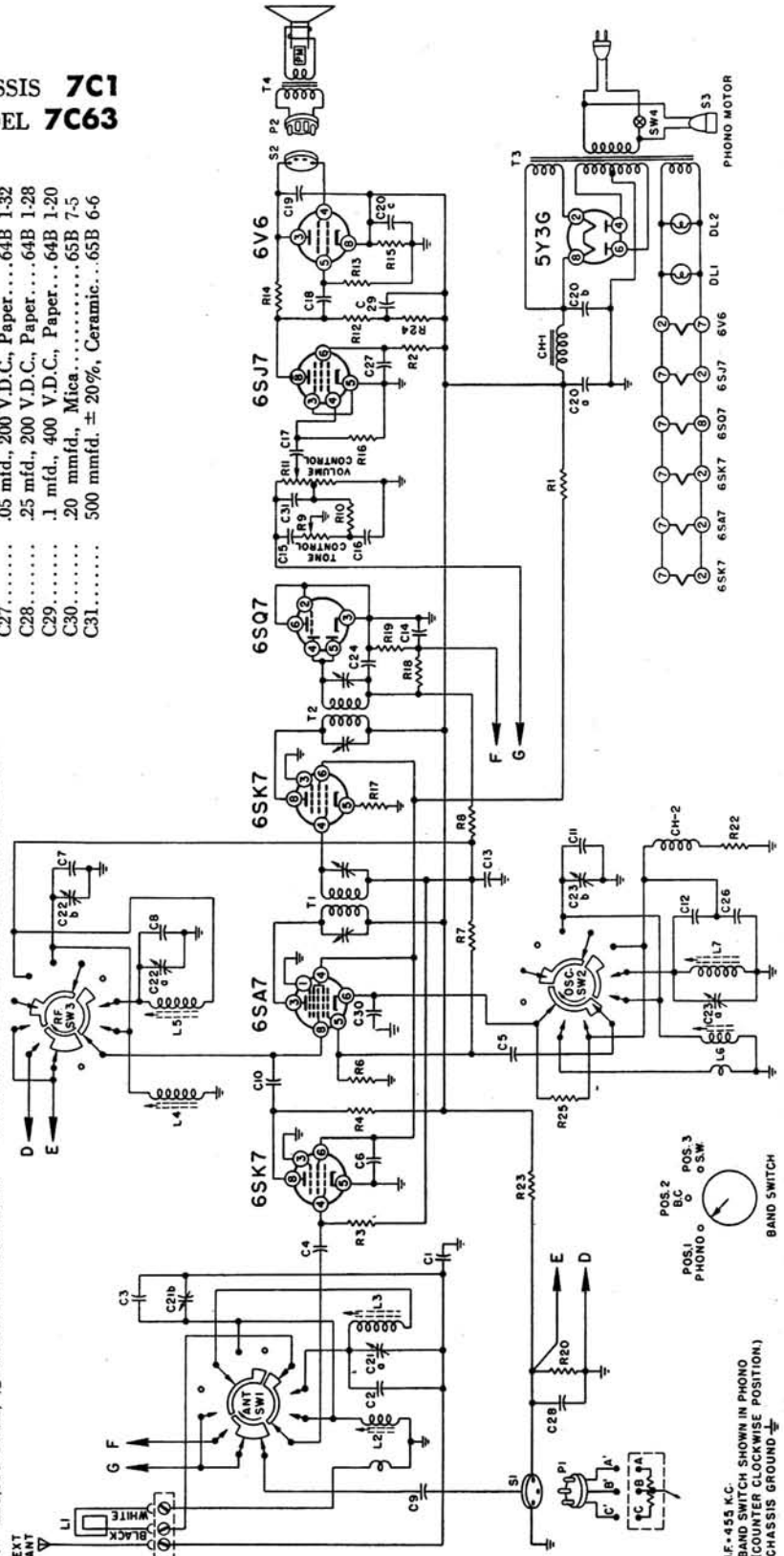

IF-455 K.C.
BAND SWITCH SHOWN IN PHONO
(COUNTER CLOCKWISE POSITION.)
CHASSIS GROUND

MANUAL OF 1948 MOST-OFTEN-NEEDED RADIO DIAGRAMS

AIRKING RADIO Model 470-1

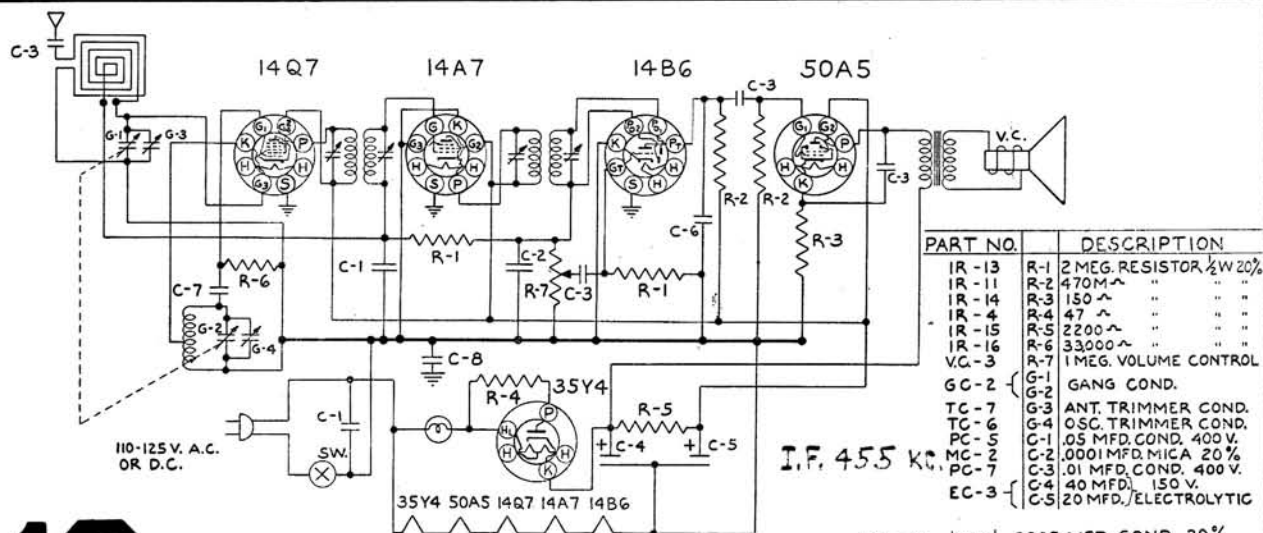
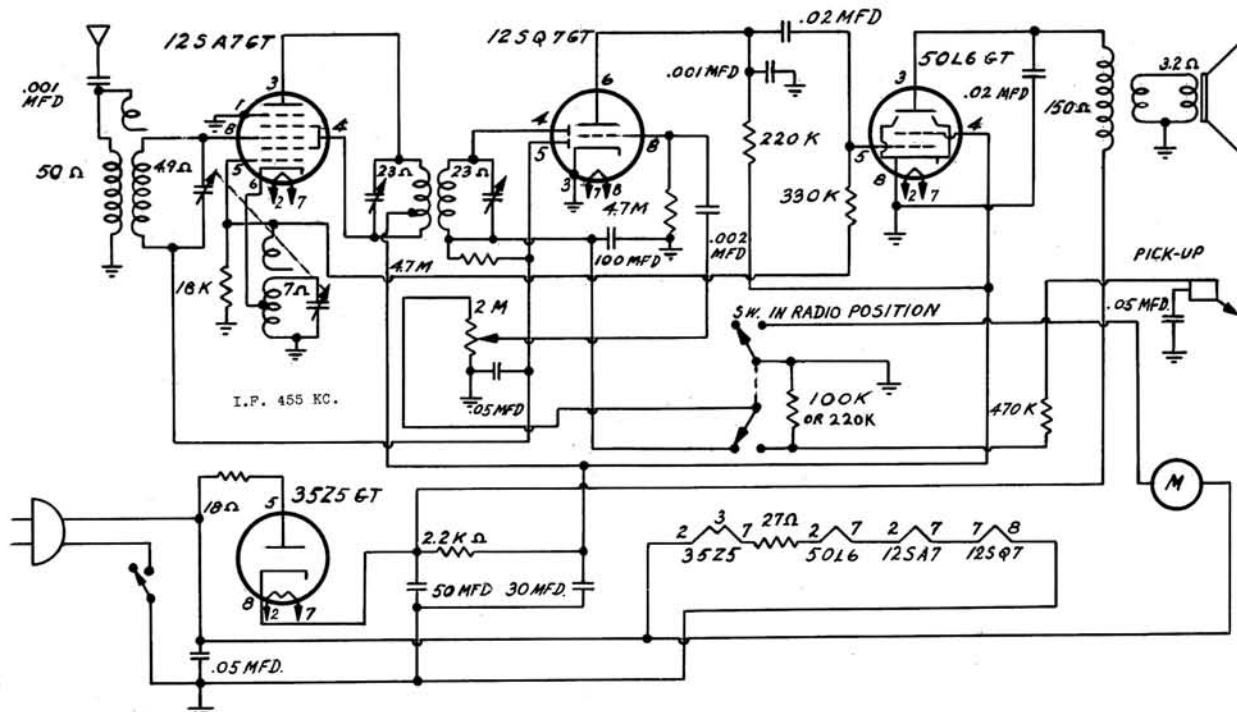

PART NO.	DESCRIPTION
IR-13	R-1 2 MEG. RESISTOR 1/2 W 20%
IR-11	R-2 470M ~ " " "
IR-14	R-3 150 ~ " " "
IR-4	R-4 47 ~ " " "
IR-15	R-5 2200 ~ " " "
IR-16	R-6 33000 ~ " " "
VC-3	R-7 1 MEG. VOLUME CONTROL
GC-2	G-1 GANG COND.
	G-2 " " "
TC-7	G-3 ANT. TRIMMER COND.
TC-6	G-4 OSC. TRIMMER COND.
PC-5	C-1 .05 MFD. COND. 400 V.
MC-2	C-2 .0001 MFD. MICA 20%
PC-7	C-3 .01 MFD. COND. 400 V.
	C-4 40 MFD. 150 V.
EC-3	C-5 20 MFD. ELECTROLYTIC

I.F. 455 KC.

MC-5 C-6 .0005 MFD. COND. 20%
 MC-4 C-7 .000056 MFD. MICA 20%
 PC-9 C-8 .1 MFD COND. 400 V.

12

Allied Radio Corp.
 Models 5B175, 5B176, 5C175, 5C176

MANUAL OF 1948 MOST-OFTEN-NEEDED RADIO DIAGRAMS

Knight RADIO

6A-127
6B-127
6C-127

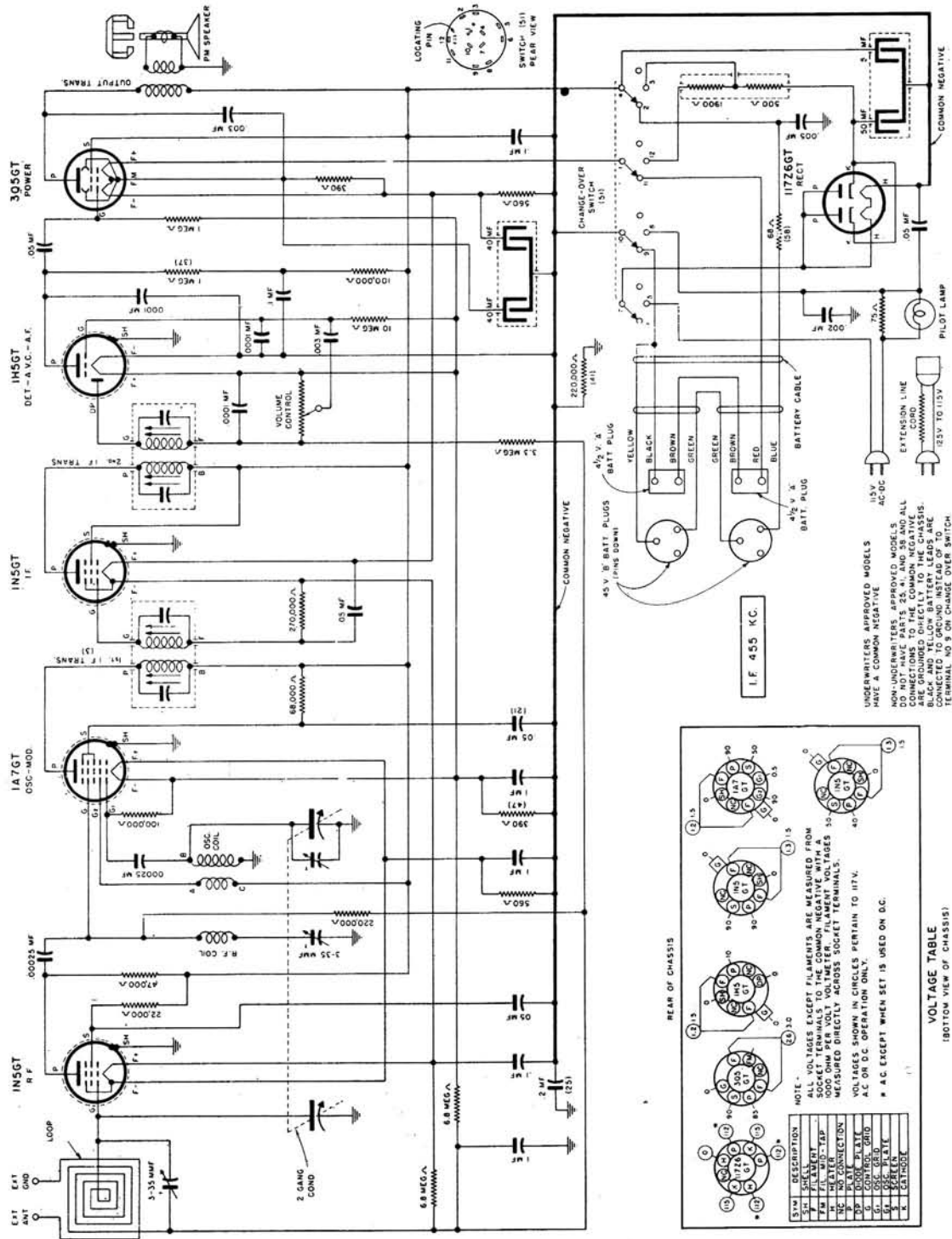

ALLIED RADIO CORPORATION

13

MANUAL OF 1948 MOST-OFTEN-NEEDED RADIO DIAGRAMS

Knight RADIO

6A-122
6B-122
6C-122

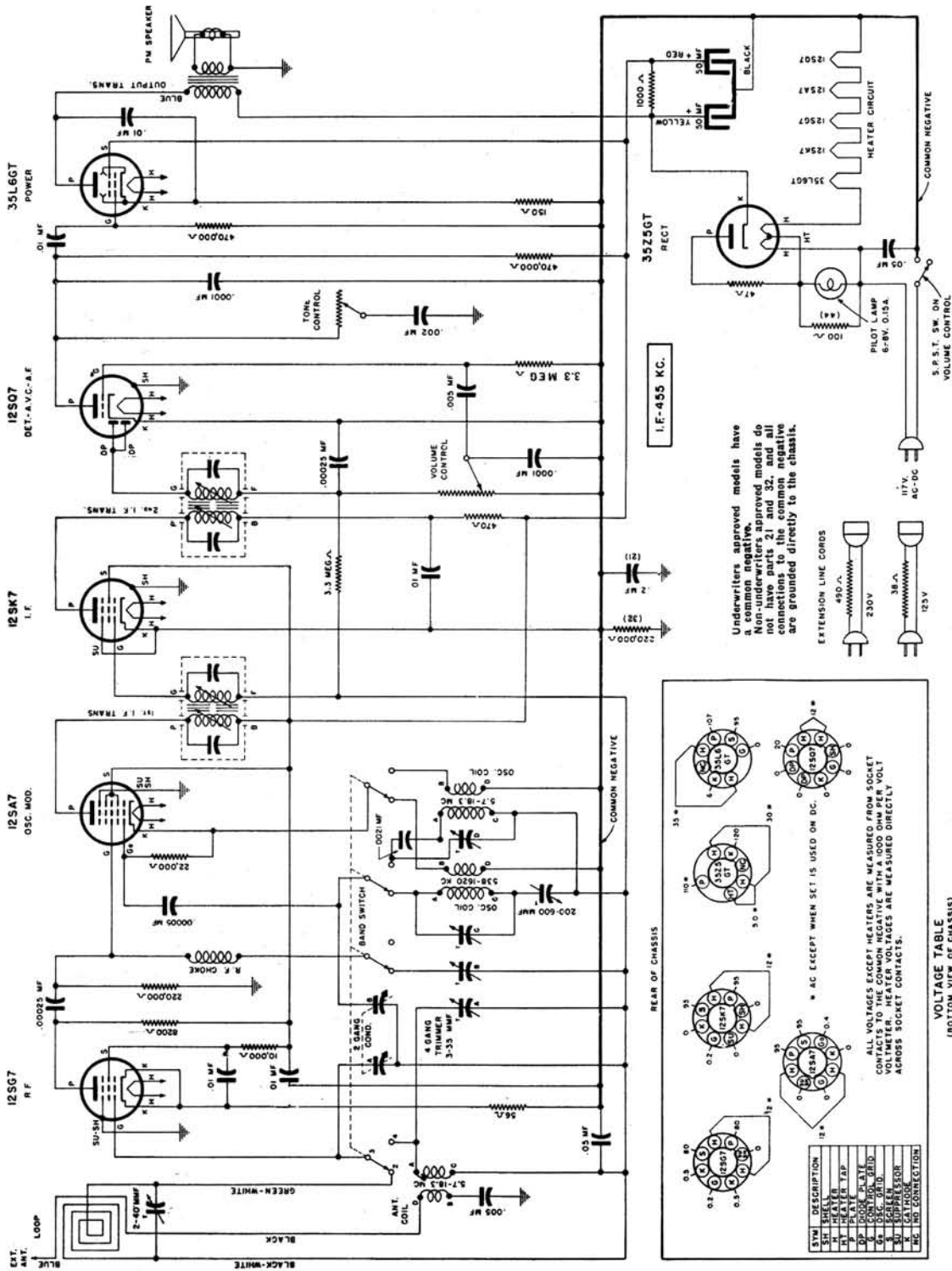

Underwriters approved models have the underwriters logo. Non-underwriters approved models do not have parts 21 and 32, and all connections to the common negative are grounded directly to the chassis.

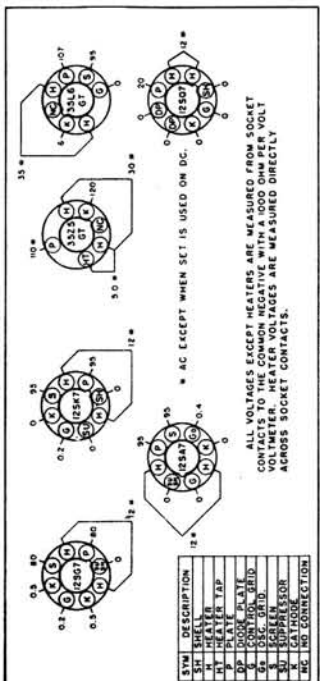
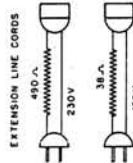

VOLTAGE TABLE
(BOTTOM VIEW OF CHASSIS)

SYM.	DESCRIPTION
SH	SHELL
H	HEATER
P	PIA
PL	PIA
DP	DIRTY
GR	GROUND
B	BATTERY
W	WATER
MC	NO CONNECTION

* AC EXCEPT WHEN SET IS USED ON DC.
ALL VOLTAGES EXCEPT HEATERS ARE MEASURED FROM SOCKET CONTACTS TO THE COMMON NEGATIVE WITH A 1000 OHM PER VOLT VOLTMETER. HEATER VOLTAGES ARE MEASURED DIRECTLY ACROSS SOCKET CONTACTS.

MANUAL OF 1948 MOST-OFTEN-NEEDED RADIO DIAGRAMS

Bendix

MODEL 416A RECEIVER

COPYRIGHT 1947 BENDIX AVIATION CORPORATION

CONDITIONS OF MEASUREMENTS
 ZERO SIGNAL INPUT VOL. CONT. MIN. SOCKET VOLTAGE RESISTANCE TO COMMON GROUND $\frac{1}{2}$ D.C. AT 20,000 Ω/V .

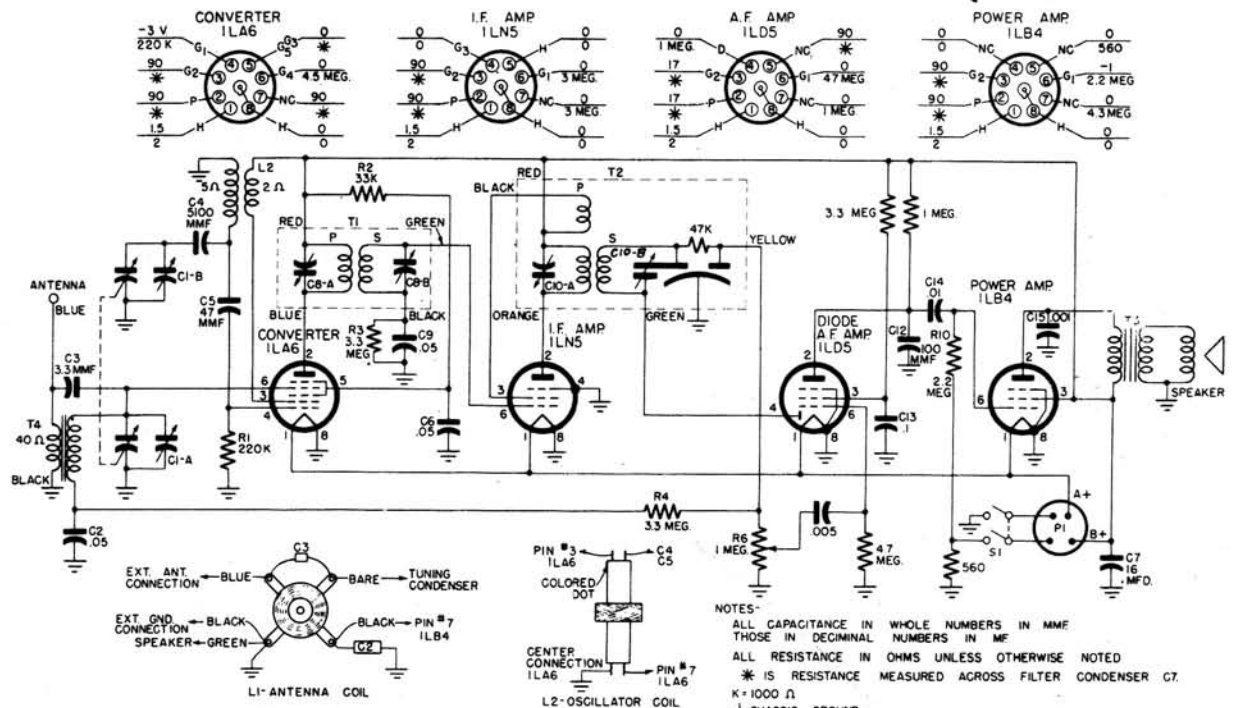

NOTES:
 ALL CAPACITANCE IN WHOLE NUMBERS IN MMF
 THOSE IN DECIMAL NUMBERS IN MF
 ALL RESISTANCE IN OHMS UNLESS OTHERWISE NOTED
 * IS RESISTANCE MEASURED ACROSS FILTER CONDENSER C7.
 K = 1000 Ω
 $\frac{1}{2}$ CHASSIS GROUND
 RANGE *540 TO 1620 KCS.

ALIGNMENT PROCEDURE

Before making any adjustments check battery voltage: the "B" supply should not be below 85 volts and the "A" supply below 1.3 volts. Connect output meter across voice coil and RF signal generator, 30% amplitude modulated, to antenna lead through a .05 mfd. capacitor for IF alignment and through 200 mfd. for oscillator and RF alignment. All adjustments made for maximum output meter reading with volume control full on. Keep output of signal generator as low as possible at all times. Rotate tuning gang to fully closed position and set dial pointer to reference mark on dial back plate before proceeding with alignment as outlined in chart below.

Input Freq.	Dial Pointer Position	Adjust
455KC	Max. to right	C10B, C10A
1475KC	1475KC	C1B, C1A
965KC	965KC	*Check Calib.
580KC	580KC	*Check Calib.

If calibration is off more than 10KC the rotor plates of the gang may be bent to correct calibration.

SET POINTER TO THIS MARK WITH GANG FULLY CLOSED

580 KC 965 KC 1475 KC

DIAL REFERENCE POINTS

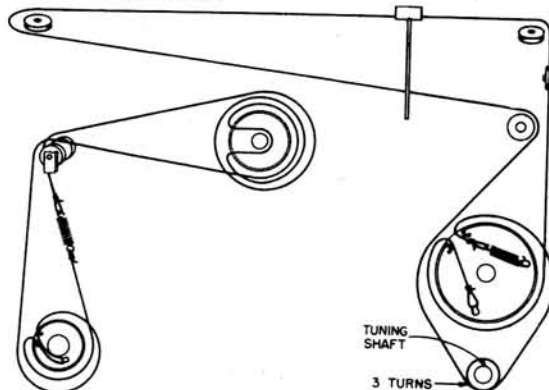
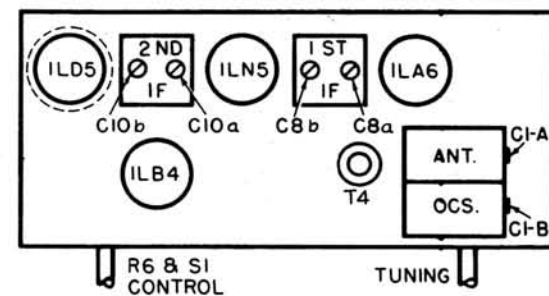

MANUAL OF 1948 MOST-OFTEN-NEEDED RADIO DIAGRAMS

Bendix Radio



SPECIFICATIONS: Model 697A

6 Tube AC-DC and Selenium Rectifier

POWER
Voltage (Chassis only).....105-125V AC or DC
Consumption (Including Changer).....72 Watts, 60 Cycle AC
TUNING RANGE.....540 - 1620 K.C.
INTERMEDIATE FREQUENCY.....455 K.C.

TUBES
12BE6 Converter
12BA6 IF Amp.
12AT6 Demodulator & 1st Audio
12BA6 Inverter
35B5 (2) Push Pull Beam Power Output

MODEL 697A

POWER OUTPUT (Max.).....3.5 Watts
PICKUP.....High Impedance Crystal
LOUDSPEAKER --- PM
Cone Diameter.....8 Inches
V.C. Impedance - 400 Cycles.....3.2 Ohms

Alignment Procedure:

PRELIMINARY:
Close gang completely and set pointer directly over reference mark on back plate, Fig. 1. Connect output meter across voice coil on low scale. Rotate volume control full on, maximum clockwise. Rotate radio-phonograph switch to radio - full C.C.W.
PRECAUTION:
An isolating transformer should be used between the power supply and the receiver if the test equipment is AC operated.

GENERAL FREQ.	POINTER POSITION	APPLY THROUGH	TO	ADJUST FOR MAX. OUTPUT
455 KC	Max. to right	.01 Mfd	Input Grid 12BE6	C6A, C6B, C8A, C8B
1475 KC	Center of 1475 Ref. Mark	50 Mmfd or less	External Ant. Conn.	C2C, C3
965 KC	Approx. 965 Ref. Mark	*	*	* Check Calibration
580 KC	Approx. 580 Ref. Mark	*	*	*

* If calibration is not within limits inscribed on back plate, oscillator and antenna gang rotor sections must be bent.

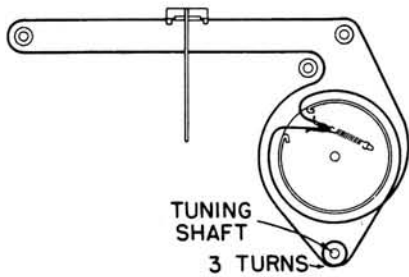

DIAL STRINGING DIAGRAM

LINE VOLTAGE 115 A-C ZERO SIGNAL INPUT VOL. CONT. MIN. CONDITIONS OF MEASUREMENTS SOCKET TO COMMON BUS ± 10% D-C AT 20,000 Ω/V A-C AT 1,000 Ω/V

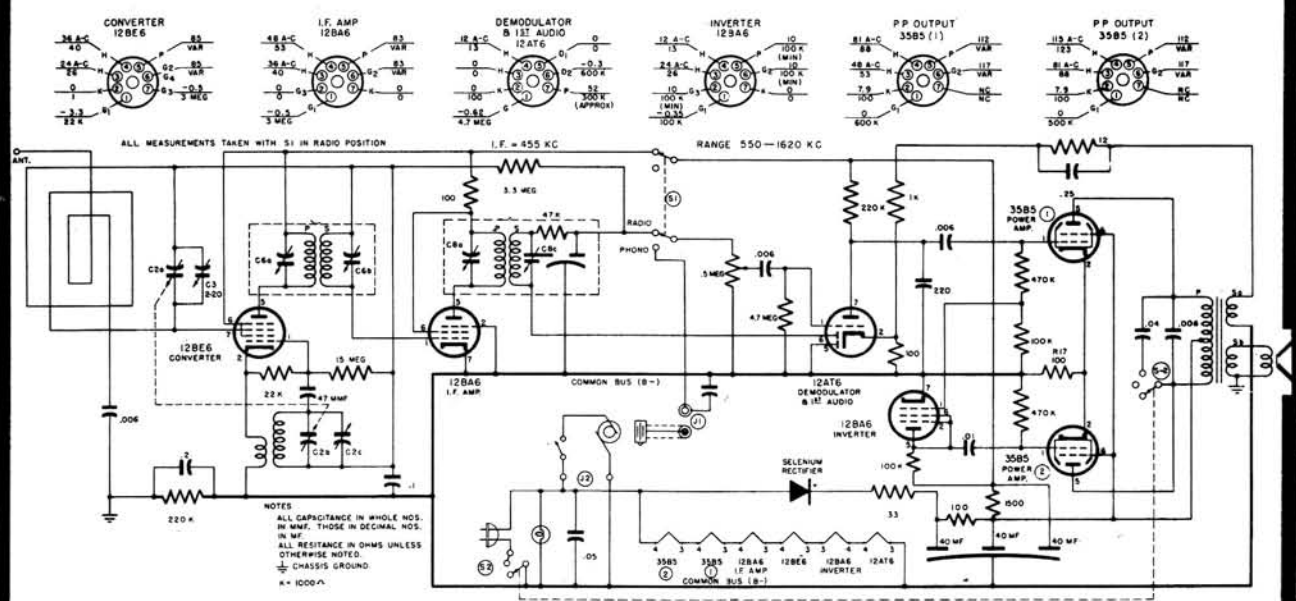

NOTES
ALL CAPACITANCE IN WHOLE NOS. IN MMF. THOSE IN DECIMAL NOS. IN MF.
ALL RESISTANCE IN OHMS UNLESS OTHERWISE NOTED.
⊥ CHASSIS GROUND.
K = 1000

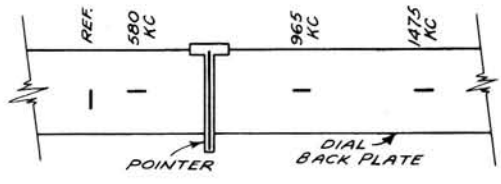
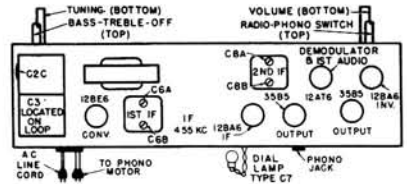

MANUAL OF 1948 MOST-OFTEN-NEEDED RADIO DIAGRAMS

Bendix Radio

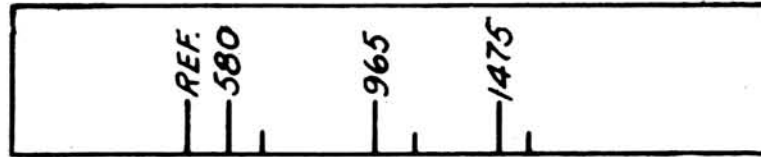

Dial Back Plate

Model R526M

5 Tube AC-DC Chassis

Power

Voltage.....105-125 V. A.C. or D.C.
 Frequency.....50-60 Cycles per Second
 Power Consumption.....30 Watts
 I.F. Frequency.....455 K.C.
 Tuning Range.....540-1620 K.C.
 Max. Power Output.....1.5 Watts
 Loud Speaker.....P.M.
 Cone Diameter.....4 Inches
 Voice Coil Impedance.....400 Cycles, 3.2 Ohms

Alignment Procedure

Set volume control at maximum. Use low range on output meter and keep signal generator input as low as practical. Make adjustments as shown in table for maximum output - with output meter connected across voice coil.

Precautions

An isolating transformer should be used between the power supply and the receiver for protection of test equipment.

ALIGNMENT CHART

Before alignment begins, set middle of pointer over "Reference" line - with Gang Condenser completely closed - See Figure 1.

CIRCUITS ALIGNED	DIAL POINTER	INPUT FREQUENCY	APPLY THROUGH	TO	ADJUST
I.F.	Max. to Right	455 K.C.	.01 Mfd	Input Grid 12BE6	C3a, C3b, C6a, C6b.
Broadcast	1475 Ref. Mark	1475 K.C.	50 Muf	External Antenna Terminal	C1d C1b
Broadcast	965 Ref. Mark	965 K.C.	50 Muf	*	Check Calibration*
Broadcast	580 Ref. Mark	580 K.C.	50 Muf	*	Check Calibration*

* If calibration does not check within one pointer's width of the frequency mark, both oscillator and antenna sections of the gang condenser must be "knifed" properly.

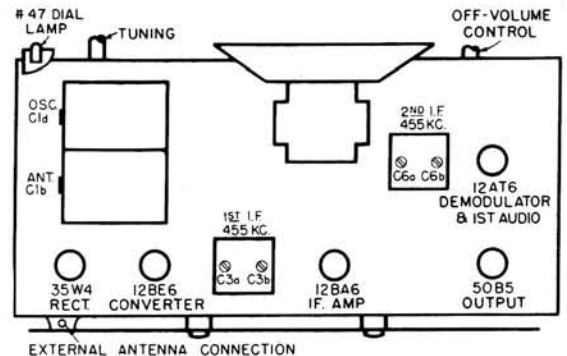

STANDARD CONDITIONS
 SOCKET VOLTAGE RESISTANCE TO COMMON BUS ±10% LINE VOLTAGE 117 V. A.C. ZERO SIGNAL INPUT VOL. CONT. MIN. DC. AT 20000 Ω/VV A.C. AT 1000 Ω/VV

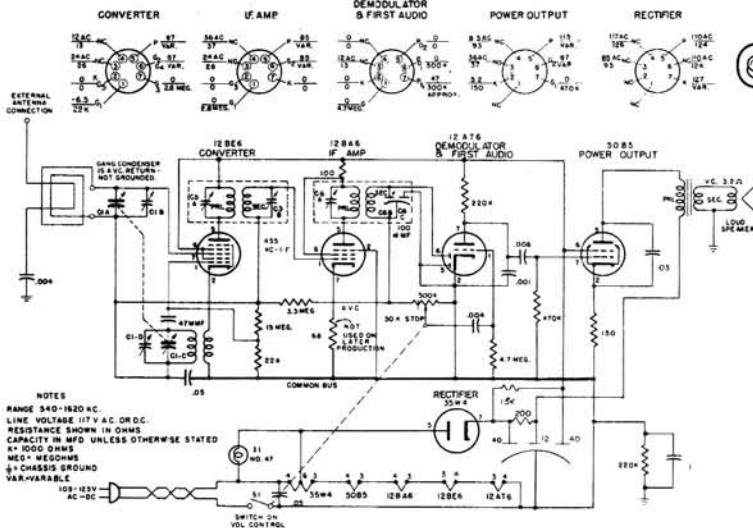

NOTES
 RANGE 540-1620 KC.
 LINE VOLTAGE 117 V. A.C. OR D.C.
 RESISTANCE SHOWN IN OHMS
 CAPACITY IN MFD. UNLESS OTHERWISE STATED
 * 1000 OHMS
 MEG = MEGOHMS
 Ⓢ = CHASSIS GROUND
 VAR = VARIABLE
 105-125V AC-DC
 SWITCH ON VOL. CONTROL

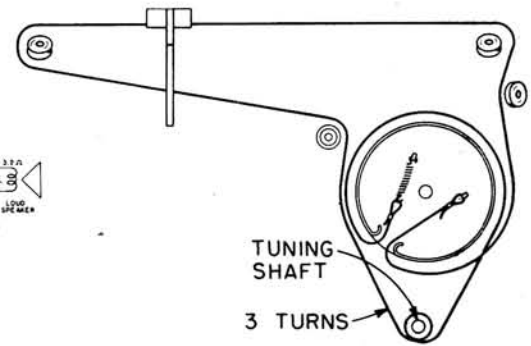

DIAL STRINGING DIAGRAM

MANUAL OF 1948 MOST-OFTEN-NEEDED RADIO DIAGRAMS

NOTES:
 1. BOTTOM VIEW OF TUBE SOCKETS.
 2. VOLTAGE MEASURED WITH AN ELECTRONIC VOLTMETER FROM SOCKET LUG TO B- (PIN 5 ON 14Q7).
 3. LINE VOLTAGE 117 V. 60 CYCLE.
 4. N.C. = NO CONNECTION.
 5. W.J. = WIRING JUNCTION.
 6. * = A.C. VOLTAGE.
 7. SOCKET VOLTAGE TOLERANCE 10 %.

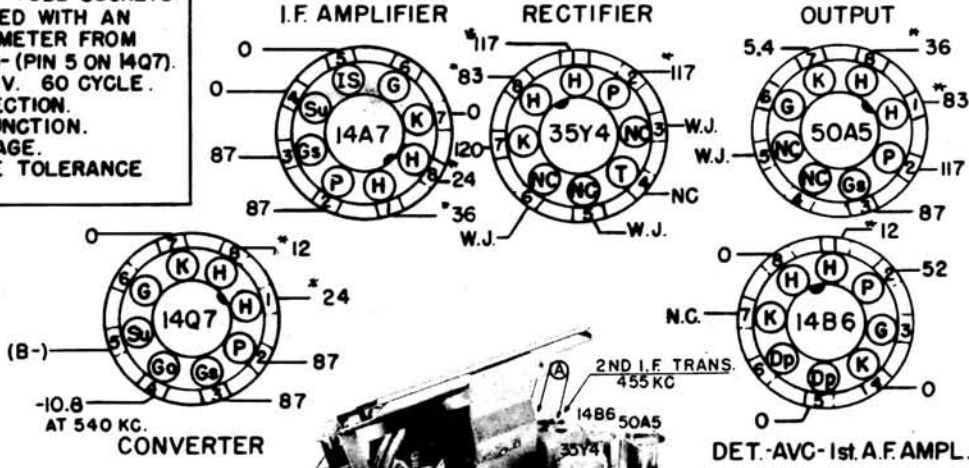

CROSLEY

MODELS 58TC, 58TW

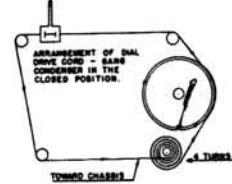
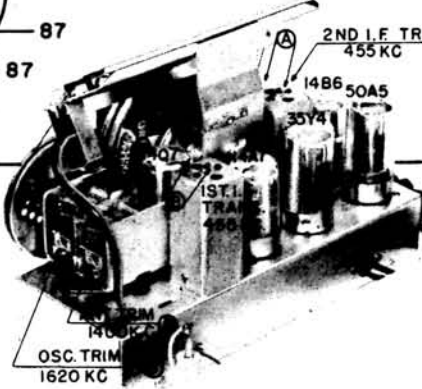

Alignment Sequence	Signal Generator Output			Position of Dial Pointer	Adjust for Maximum Output
	Frequency in kc.	In Series with	To		
1	455	200 mmf.	Ant.	1620	A & B
2	1620	200 mmf.	Ant.	1620	C
3	1400	200 mmf.	Ant.	1400	D

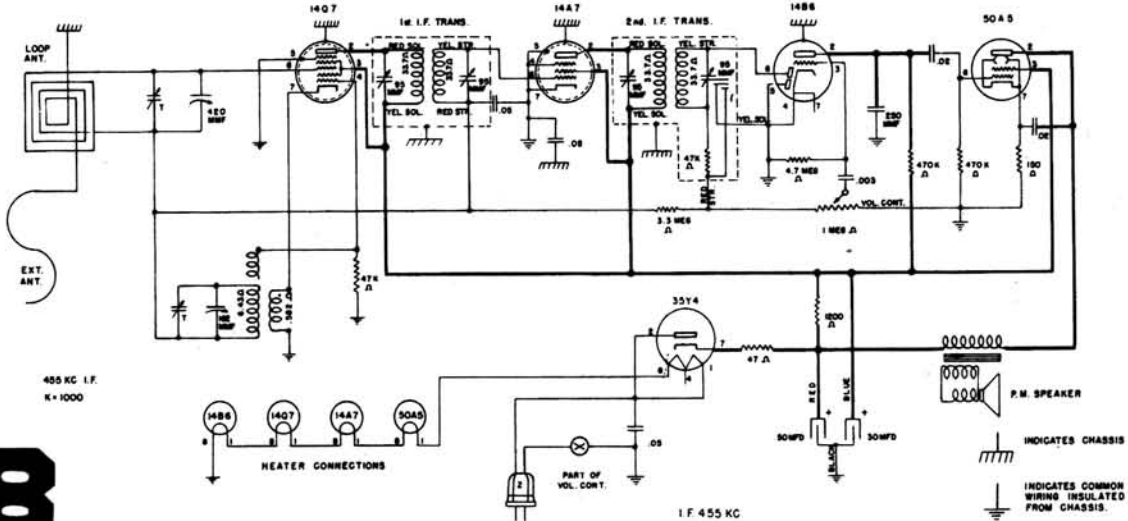

MANUAL OF 1948 MOST-OFTEN-NEEDED RADIO DIAGRAMS

Alignment Sequence	Signal Generator Output			Position of Tuning Dial KC	Adjust for Maximum Outout
	Frequency in KC	In Series with	To		
1	455	200 mmf.	Ant.	1620	A & B
2	1620	200 mmf.	Ant.	1620	C
3	1400	200 mmf.	Ant.	1400	D

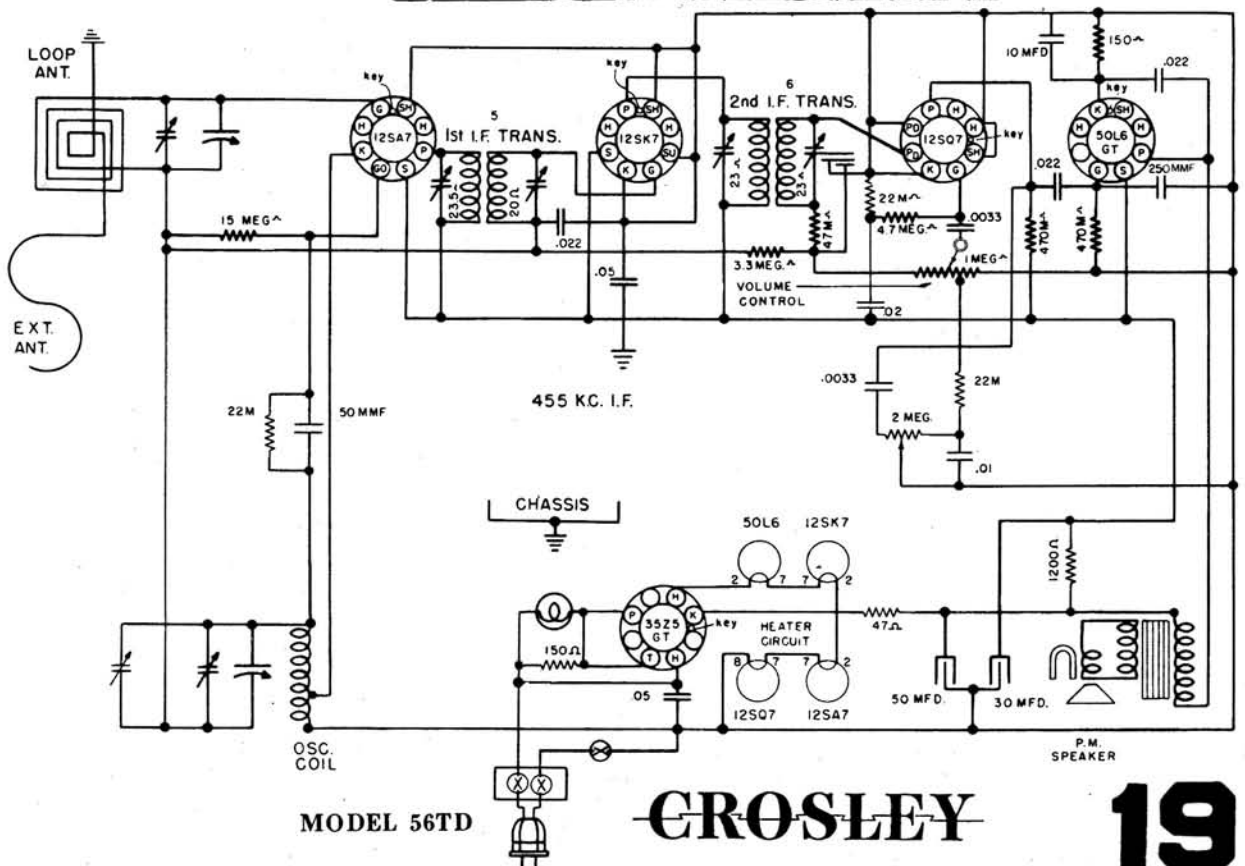
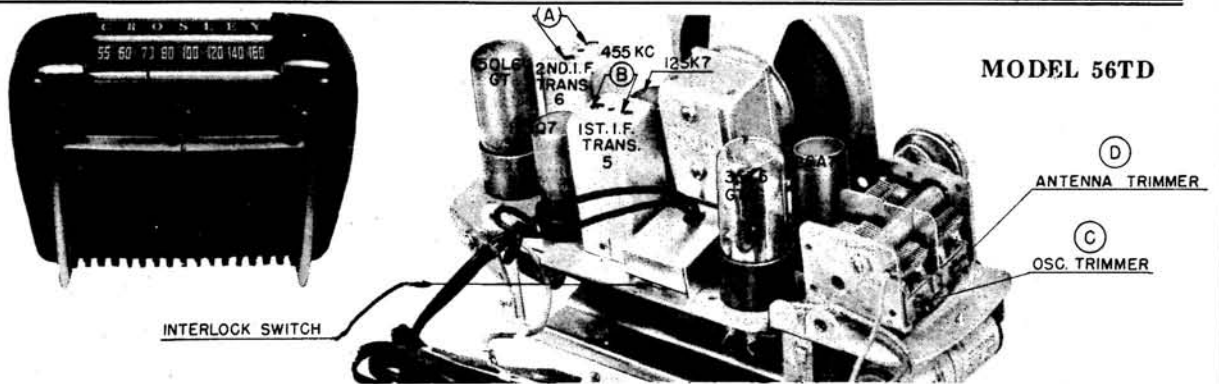

MANUAL OF 1948 MOST-OFTEN-NEEDED RADIO DIAGRAMS

CROSLEY

ALIGNMENT PROCEDURE—MODEL 56TN

1. Turn the tuning condenser to the completely closed position against the stop and set the dial pointer to the reference line at the end of the dial scale.
2. Connect the output meter across the speaker voice coil.
3. The r.f. signal input from the signal generator should be connected to the external antenna lead. Connect the signal generator ground through a 0.1 mfd. condenser to —B (pin 3 on 12SK7 tube socket).
4. Turn the volume control on full and adjust the signal generator output to produce approximately mid-scale deflection of the output meter, but maintain signal generator output as low as possible to prevent AVC action in the receiver.

Alignment Sequence	Signal Generator Output			Position of		Adjust for Maximum Output
	Frequency in kc.	In Series with	To	Band Switch	Tuning Dial	
1	455	200 mmf.	Ant.	Left	1,620	A & B
2	15,300	400 ohms	Ant.	Right	15,300	C
3	15,000	400 ohms	Ant.	Right	15,000	D
4	1,400	200 mmf.	Ant.	Left	1,400	E & F

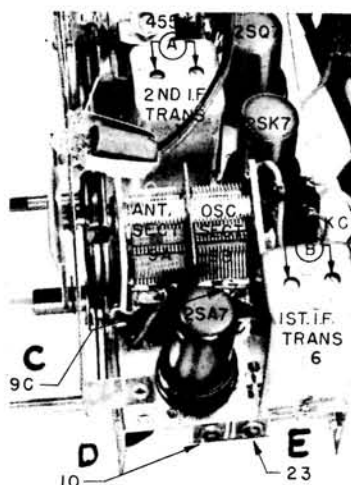

NOTE: When aligning the short-wave oscillator trimmer (C), be sure that the circuit is aligned at the correct frequency and not at the image frequency which is 910 kilocycles lower as indicated by the receiver dial. To check: Tune in the generator frequency, then increase the generator output and tune in the image frequency. The image frequency should be weaker than the fundamental and audible 910 kilocycles lower on the receiver dial. If the image cannot be tuned in, the oscillator trimmer is adjusted to the wrong peak; i.e., the oscillator trimmer may be adjusted to the image or one of the harmonics instead of the fundamental frequency. The correct peak is the second one heard as the trimmer adjustment screw is opened from the completely closed position.

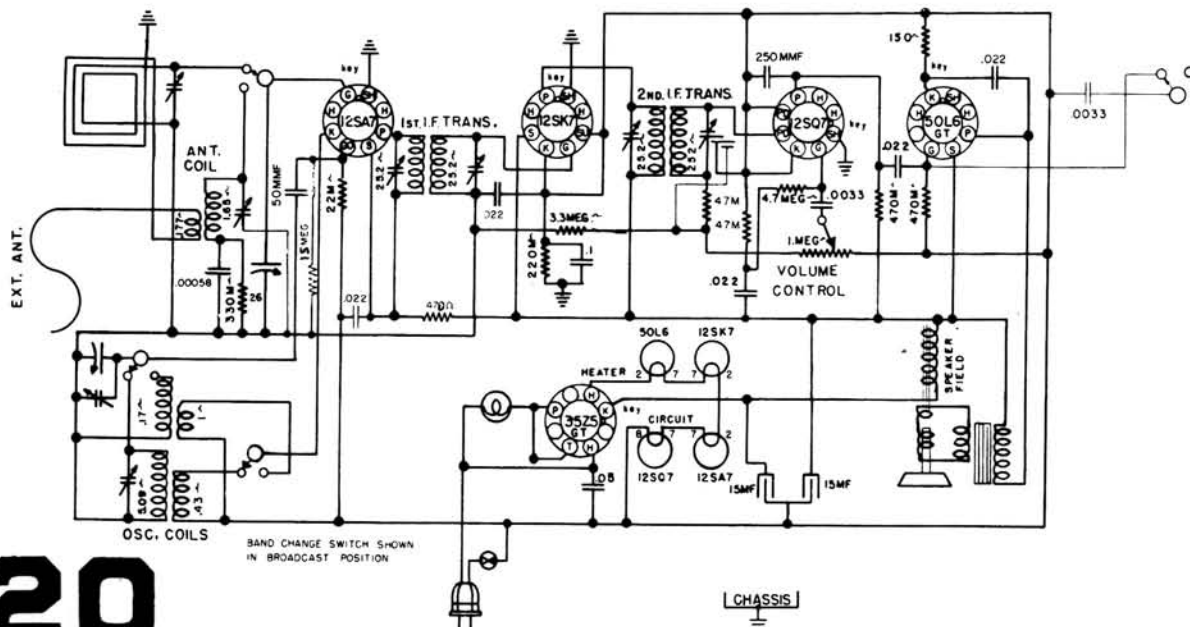

MANUAL OF 1948 MOST-OFTEN-NEEDED RADIO DIAGRAMS

MODELS 56TZ, 56TQ, 2nd PRODUCTION

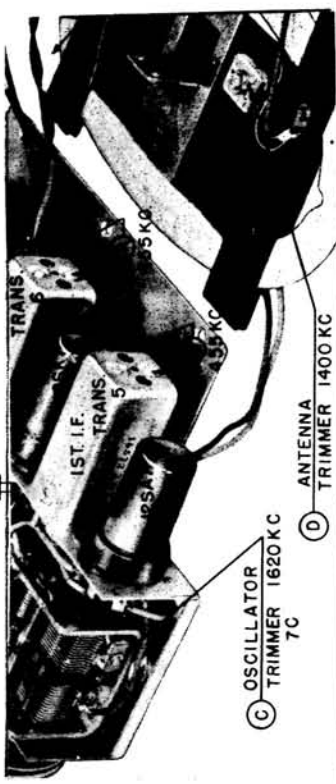
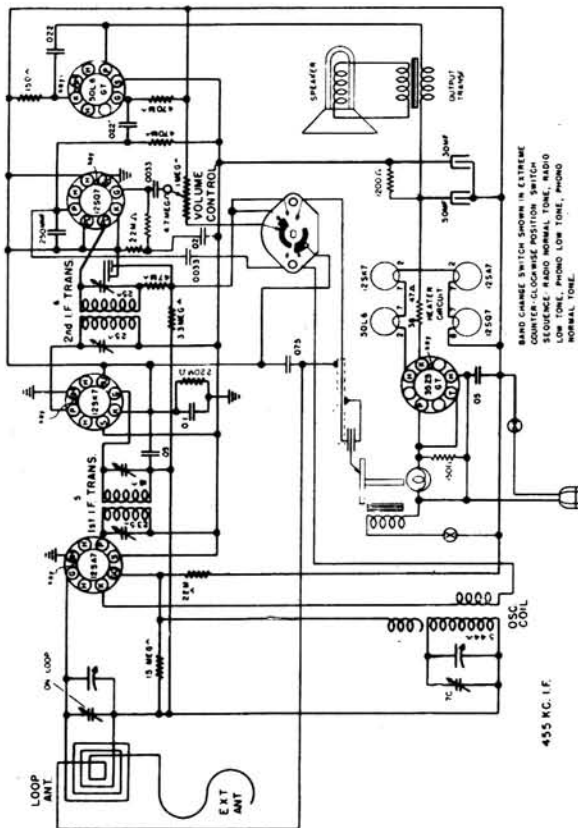

MODELS 56TZ, 57TQ, 1st PRODUCTION

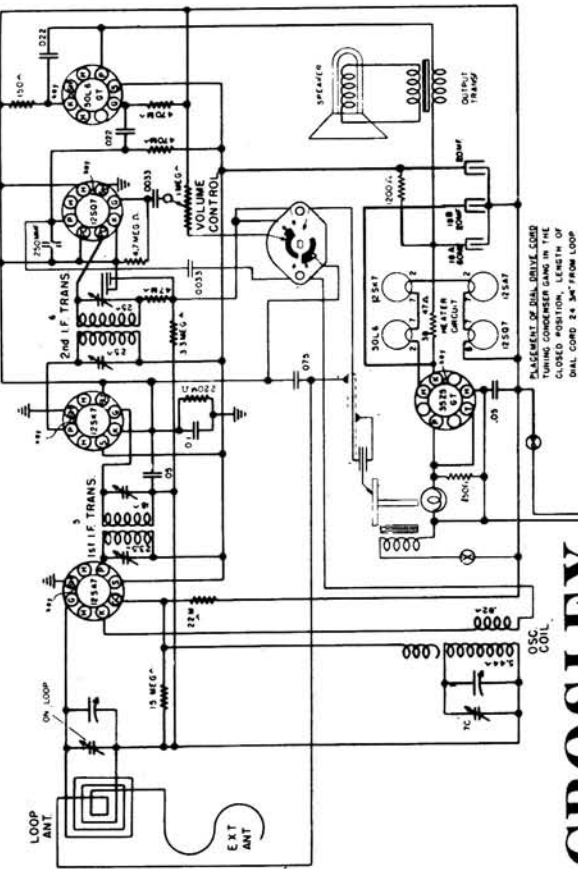

CROSLLEY

MODELS: 56TZ, 57TQ

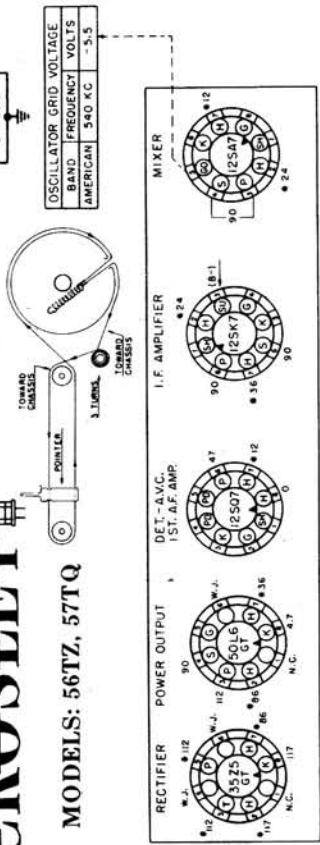

Alignment Sequence	Signal Generator Output		Position of	
	In Series with	To	Selector Switch	Tuning Dial
1	200 mmf.	Ant.	R	1620
2	200 mmf.	Ant.	R	1620
3	200 mmf.	Ant.	R	1400

NOTES:
 1. THESE ARE BOTTOM VIEWS OF TUBE SOCKETS.
 2. MEASURE VOLTAGES FROM SOCKET LUGS TO B-(PIN 3 ON THE 12SK7).
 3. THESE VOLTAGES WERE MEASURED USING AN ELECTRONIC VOLTMETER.
 4. W.-J. - WIRING JUNCTION.
 5. N.C. - NO CONNECTION.
 6. * - 60 CYCLE A.C. VOLTAGES.
 7. SOCKET VOLTAGE TOLERANCE, 10%.
 8. LINE VOLTAGE 117 V, 60 ~ A.C.

MANUAL OF 1948 MOST-OFTEN-NEEDED RADIO DIAGRAMS

ALIGNMENT PROCEDURE

1. Turn the tuning condenser to the completely closed position against the stop and set the dial pointer to the reference line at the end of the dial scale.
2. Connect the output meter across the speaker voice coil.
3. The r.f. signal input from the signal generator should be connected to the external antenna lead. Connect the signal generator ground through a 0.1 mfd. condenser to —B (pin 4 on 14A7 tube socket).
4. Turn the volume control on full and adjust the signal generator output to produce approximately mid-scale deflection of the output meter, but maintain signal generator output as low as possible to prevent AVC action in the receiver.

CROSLEY

MODEL 56TY

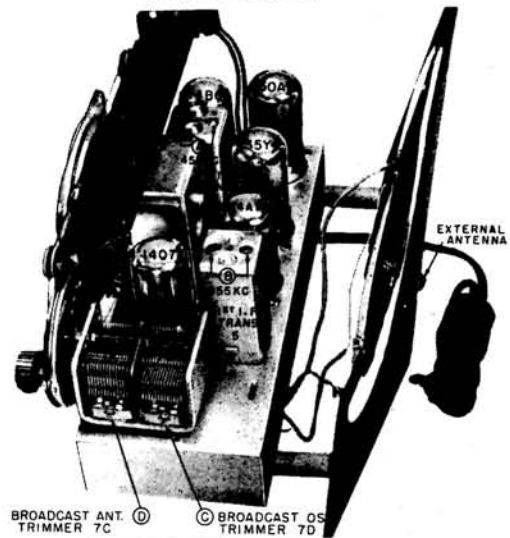

Alignment sequence	Signal Gen. Output			Position of Tuning Dial	Adjust for max. output
	Frequency in KC	In Series with	To		
1	455	200 mmf.	Ant.	1620	A & B
2	1620	200 mmf.	Ant.	1620	C
3	1400	200 mmf.	Ant.	1400	D

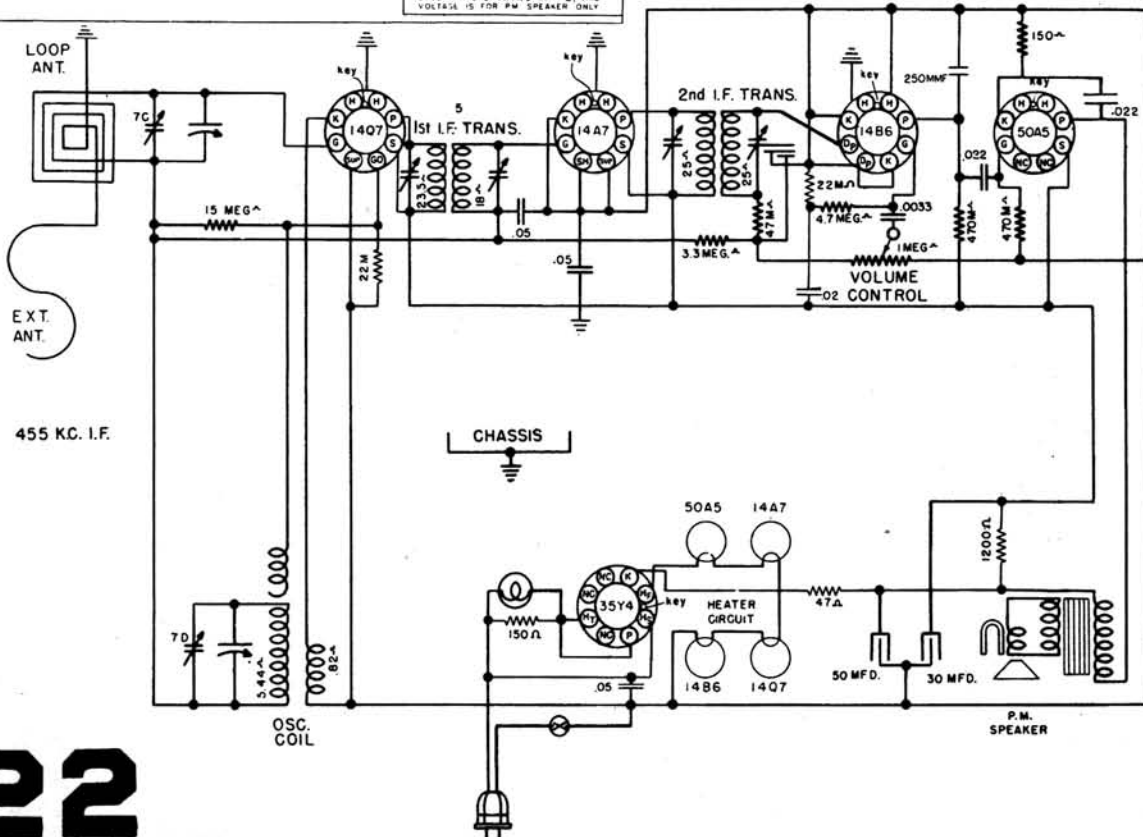
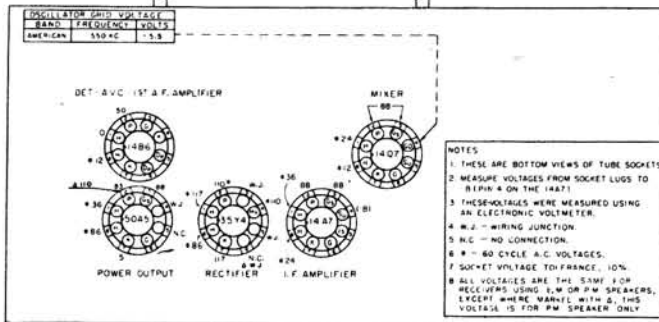

MANUAL OF 1948 MOST-OFTEN-NEEDED RADIO DIAGRAMS

Item No.	Part No.	Description	Item No.	Part No.	Description
2	C-132300-1	Cable and Plug Assy., Power	21	39373-60	Resistor, 22,000 ohm, 1/2 w.
3	AC-135209	Loop and Back Assy., Antenna	23	39373-100	Resistor, 3.3 megohm, 1/2 w.
4	AW-135195	Coil Assy., Oscillator	25	39373-144	Resistor, 1200 ohm, 1 w.
5	AW-137665	Transformer, 1st I. F.	26	39373-102	Resistor, 4.7 megohm, 1/2 w.
6	AW-137667	Transformer, 2nd I. F.	27	39373-87	Resistor, 470,000 ohm, 1/2 w.
8 A	B-135056	Condenser, Variable } Two	28	39373-87	Resistor, 470,000 ohm, 1/2 w.
8 B		Condenser, Variable } Section	29	39373-16	Resistor, 150 ohm, 1/2 w.
8 C	Part of Item #8A	Condenser, Trimmer	30 A	C-135127	Control, Volume (1 megohm) } Assy.
8 D	Part of Item #8B	Condenser, Trimmer	30 B		Switch, Power } Control, Volume }
9	39001-17	Condenser, .05 mfd., 600 v., paper	*	39368-14	Control, Volume
10	39001-17	Condenser, .05 mfd., 600 v., paper	*	39369-1	Switch, Power
12	39001-73	Condenser, 250 mfd., 600 v., paper	31	B-137723	Transformer, Output
13	39001-73	Condenser, .003 mfd., 600 v., paper	33	W-137367	Resistor, 47 ohm, 1 w.
14	39001-80	Condenser, .02 mfd., 600 v., paper	34	Part of Item #6	Resistor, 47,000 ohm, 1/2 w.
15	39001-80	Condenser, .02 mfd., 600 v., paper		W-135164	Bumper, Rubber
17	B-136768	Speaker		R-135162	Cabinet, (57TK)
18	39001-17	Condenser, .05 mfd., 600 v., paper		AW-135246	Cabinet, (57TL)
19 A	B-136770	Cond'ser, 50 mfd., 150 v. Two Sect.		W-131154-1	Cotter, External
19 B		Cond'ser, 30 mfd., 150 v. Elec. Filter		B-135713	Dial Glass
20	39373-109	Resistor, 15 megohm, 1/2 w.		W-134055	Grommet, Var. Cond. Mtg

DET. - AVC. 1st. A.F. AMPL.

MIXER

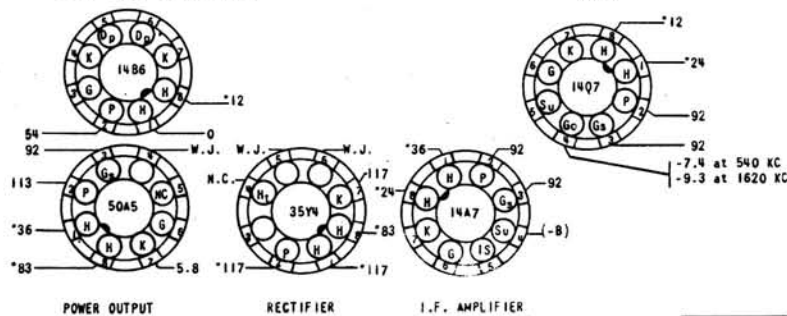

MODELS: 57TK, 57TL

- NOTES:
1. These are bottom views of tube sockets.
 2. Measure voltages from socket lugs to -5 (pin 4 on the 14A7).
 3. These voltages were measured using an electronic voltmeter. Line voltage 117.
 4. W.J. = Wiring junction
 5. N.C. = No connection
 6. * = 60 cycle A.C. voltages.
 7. Socket voltage tolerance 10%.

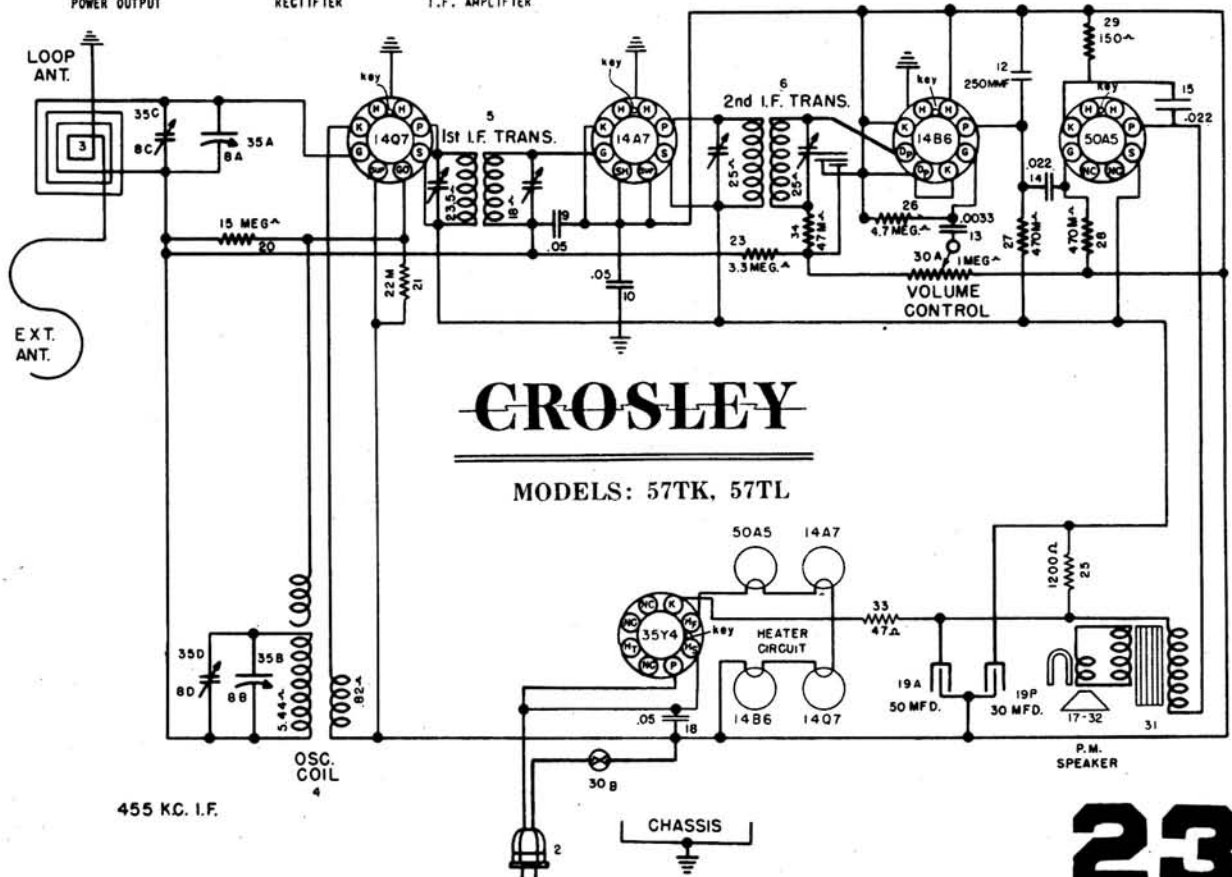

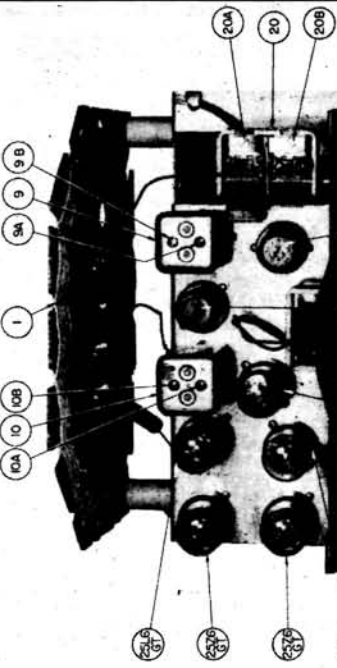

OFTEN-NEEDED RADIO DIAGRAMS

ECA ELECTRONIC CORP. OF AMERICA RADIO 108

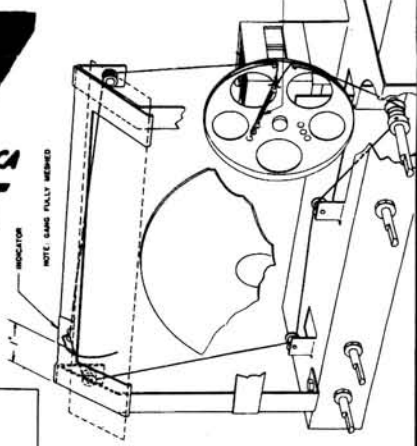

SET SIGNAL GENERATOR AT	SET GANG	LOOP DISTANCE	ADJUST TRIMMER	TUNE FOR
455 KC	Meshed	Close	9a 9b 10a 10b	Max.
1720 KC	Fully Open	Close	20a	Max.
1400 KC	1400 KC	Close	20b	Max.

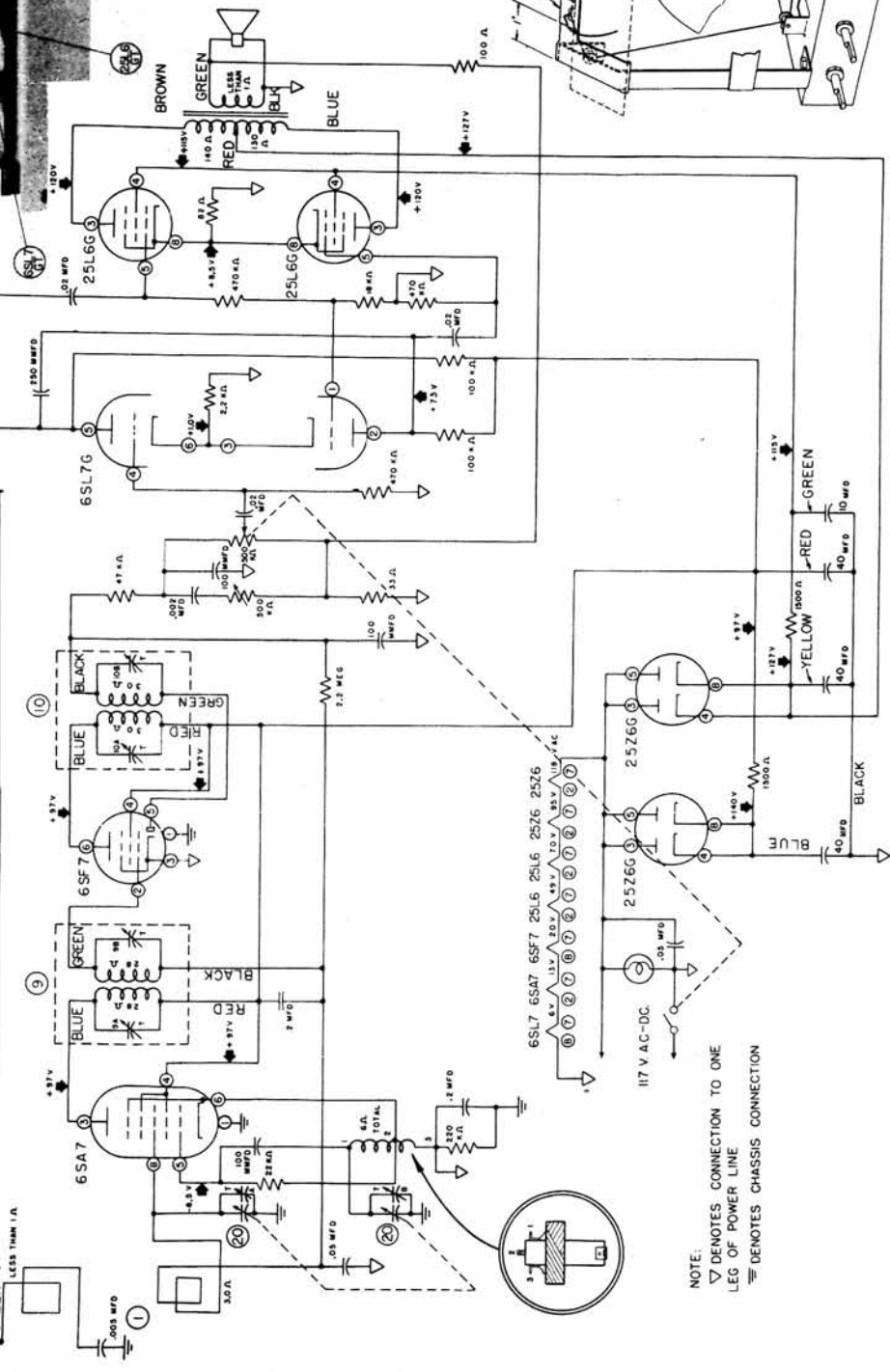

NOTE:
 ▽ DENOTES CONNECTION TO ONE LEG OF POWER LINE
 ≡ DENOTES CHASSIS CONNECTION

MANUAL OF 1948 MOST-OFTEN-NEEDED RADIO DIAGRAMS



ELECTRONIC CORP. OF AMERICA

RADIO

104 & 106

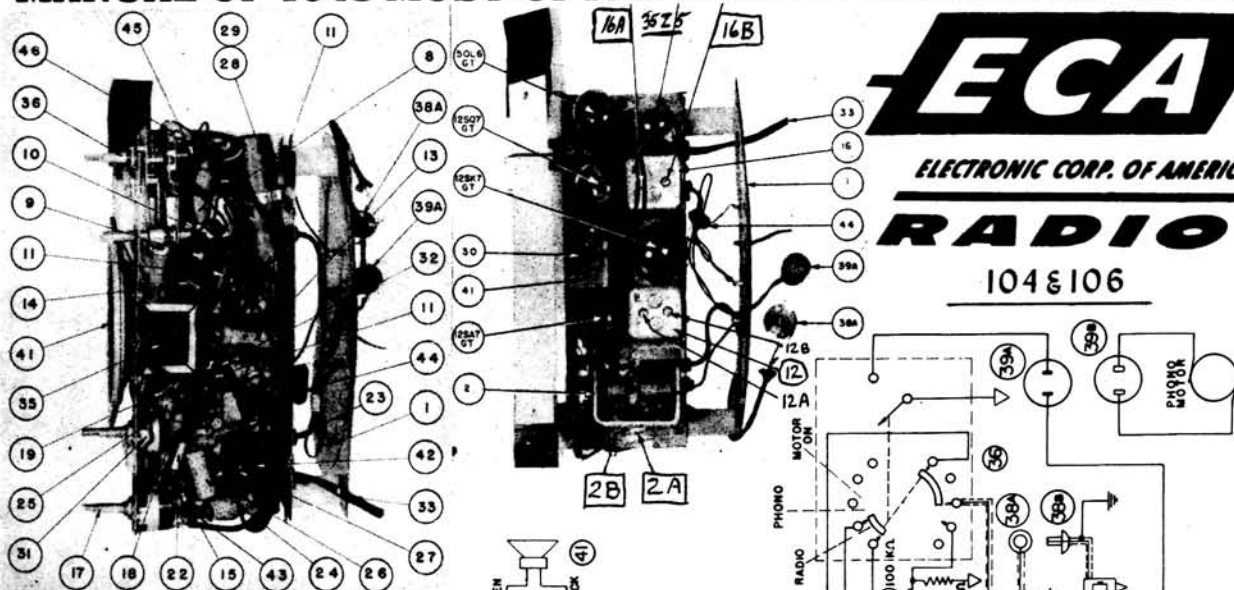

SET SIGNAL GENERATOR AT	SET GANG	LOOP DISTANCE	ADJUST TRIMMER	TUNE FOR	OPERATION
455 KC	Meshed	Close	12a 12b 16a 16b	Max.	Align - I.F.
1720 KC 1400 KC	Fully Open 1400 KC	Close Close	2b 2a	Max. Max.	Align Oscillator Align - R.F.

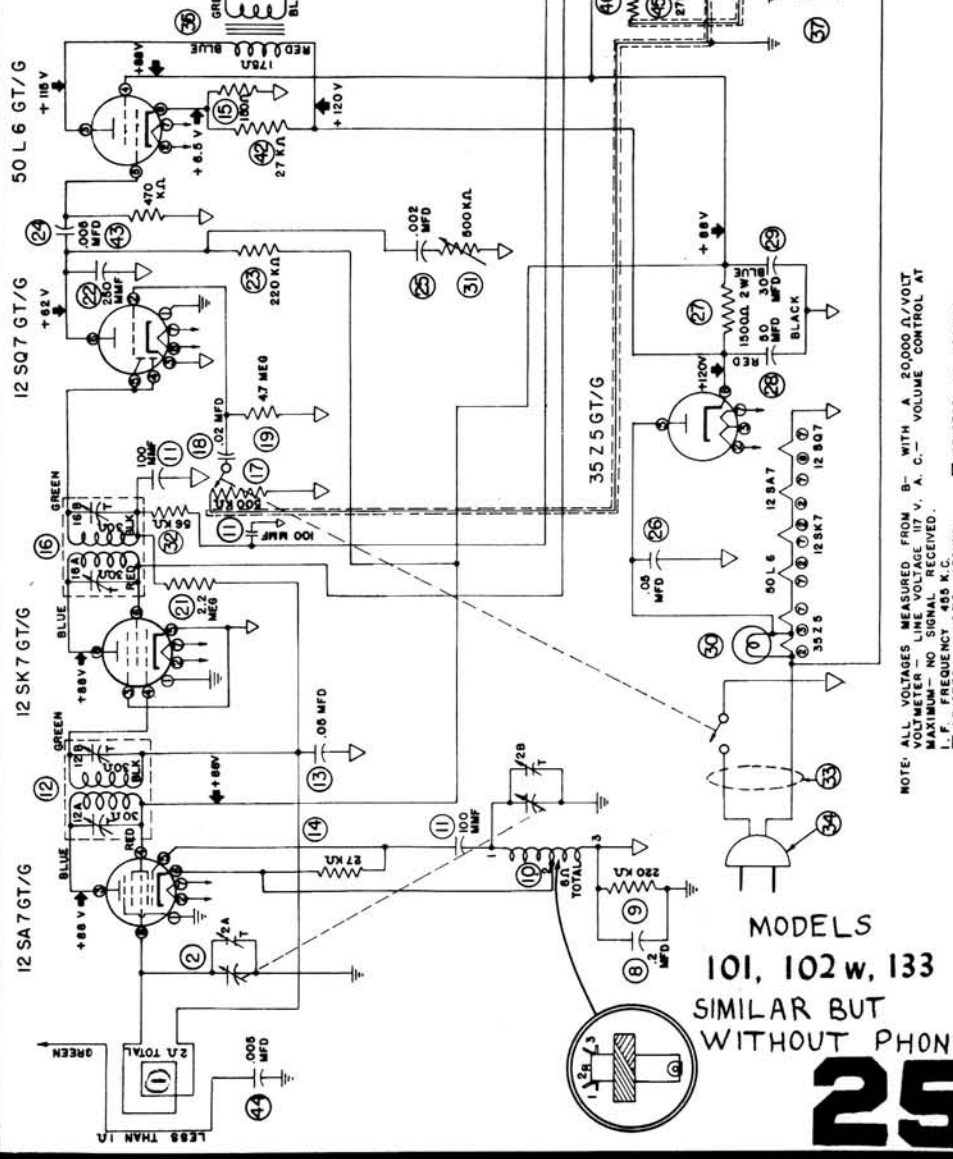

MODELS
101, 102w, 133
SIMILAR BUT
WITHOUT PHONO
25

Emerson Radio

MODEL: 540A

CHASSIS MODEL: 120042A

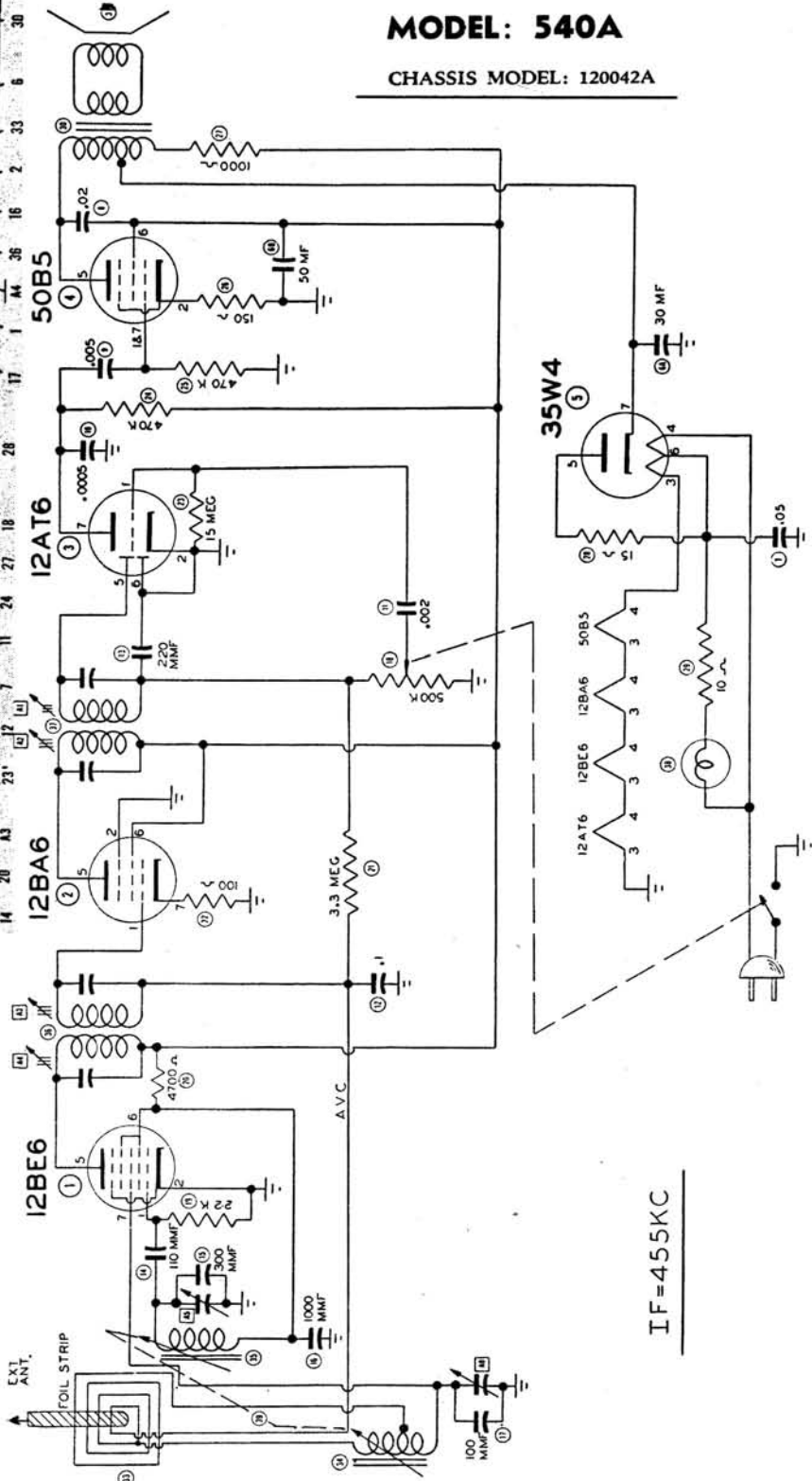
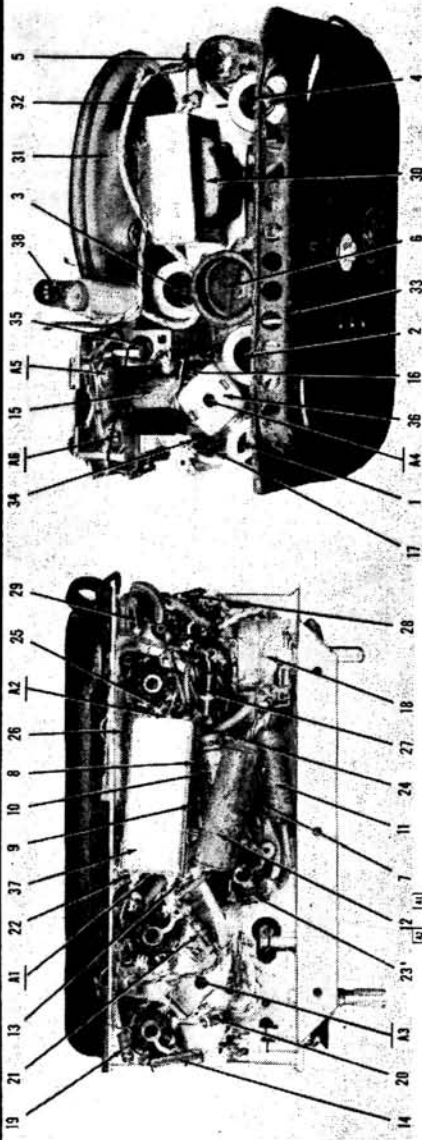

IF=455KC

4 1/2 TURNS

MANUAL OF 1948 MOST-OFTEN-NEEDED RADIO DIAGRAMS

Emerson Radio

MODELS: 511, 517, 541

CHASSIS MODEL: 120010

TUBE	PIN NUMBER							
	1	2	3	4	5	6	7	8
12SA7			89	89	*—10			*—1.6
12SK7				*—1.6		89		89
12SQ7		*—0.7		*—1.6	*—0.5	37.5		
50L6			110	89				6.2
35Z5				116		116		117

The following voltage readings are d-c measurements taken from B— (line switch) to the indicated tube-socket pin. A 1000 ohms-per-volt meter should be used for all readings except those indicated by an asterisk (*), which should be taken with a d-c vacuum-tube voltmeter. Line voltage for these readings was 117 volts, 60 cycles, a.c. Measurements made with 117 volts d.c. will be lower than those given below. Take readings with the volume control set at minimum and the variable condenser closed.

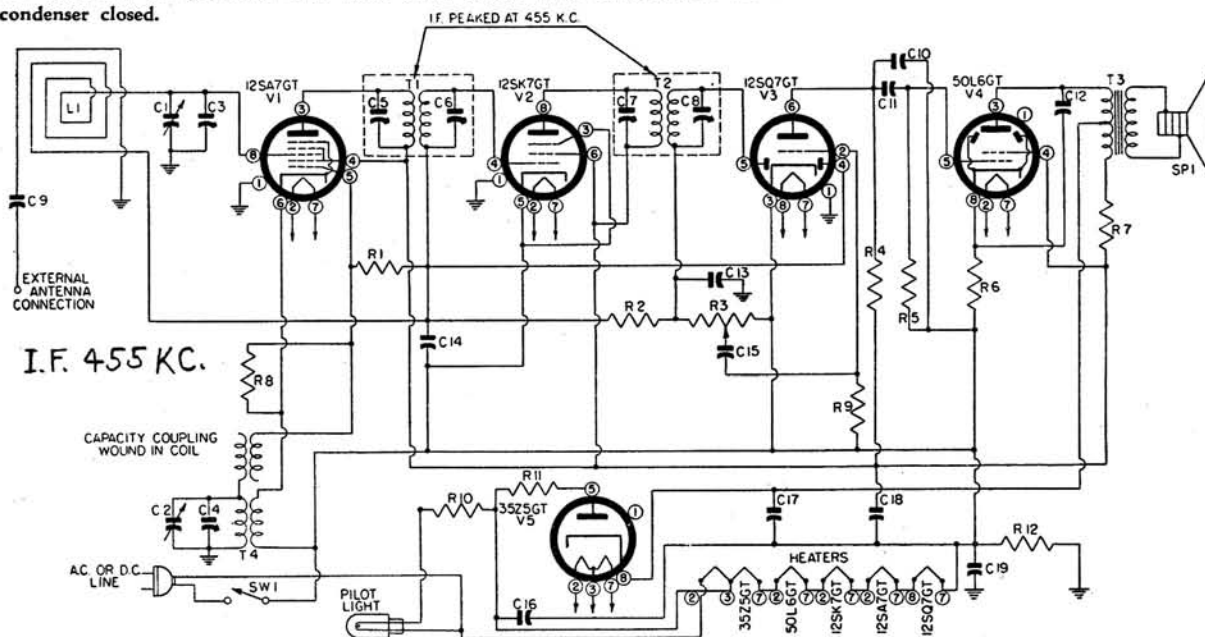

Schematic Symbol	†Part No.	DESCRIPTION	Schematic Symbol	†Part No.	DESCRIPTION
C1, C2	900160	Two-gang variable condenser	R2	321330	3.3 meg., ¼ watt carbon resistor
*C3, C4		Trimmers, part of variable condenser	R3	390000	Volume control with line switch
*C5, C6, } C7, C8 }		Trimmers, part of i-f transformers	R4, R5	321130	470,000 ohms, ¼ watt carbon resistor
C9, C15	920010	0.002 mfd., 600 V. paper condenser	R6	340290	150 ohms, ½ watt carbon resistor
C10	920240	500 mmfd., 600 V. paper condenser	R7	370490	1000 ohms, 1 watt carbon resistor
C11, C12	920020	0.02 mfd., 400 V. paper condenser	R8	310810	22,000 ohms, ¼ watt carbon resistor
C13	910000	220 mmfd., 600 V. mica condenser	R10	340010	6.8 ohms, ¼ watt carbon resistor
C14	920040	0.1 mfd., 200 V. paper condenser	R11	397040	15 ohms, 1 watt wire-wound resistor
C16	920030	0.05 mfd., 400 V. paper condenser	R12	321050	220,000 ohms, ¼ watt carbon resistor
C17, C18	925000	Dual electrolytic condenser, 150 V.; C20—30 mfd., C21—50 mfd.	SP1	180000	P.M. Speaker
C19	920050	0.2 mfd., 200 V. paper condenser	*SW1		Line switch, part of volume control
L1	700000	Loop antenna assembly, or	T1	720000	First i-f transformer
L1	700200	Loop antenna assembly	T2	720100	Second i-f transformer
R1, R9	397000	15 meg., ¼ watt carbon resistor	T3	734000	Output transformer
			T4	716010	Oscillator coil
				583010	Line cord

MANUAL OF 1948 MOST-OFTEN-NEEDED RADIO DIAGRAMS

EMERSON RADIO

MODELS: 512, 515, 516, 550

CHASSIS MODELS: 120006, 120056 **530**

The 455 kc wave-trap is located below the chassis deck.

The trimmers for the antenna and oscillator coils are located on the variable condenser. The trimmer on the front section is for the oscillator coil.

The oscillator coil is located underneath the chassis. The loop antenna acts as the antenna coil.

I-f and Wave-Trap Alignment

Swing the variable condenser to the minimum capacity position. Feed 455 kc to the grid of the 12SA7 or 14Q7 tube through a 0.1 mfd. condenser and adjust the four i-f trimmers for maximum response.

Feed 455 kc to the external antenna lead and adjust the wave-trap for minimum response.

R-f Alignment

Set the dial pointer at 140. Set the signal generator at 1400 kc and feed its output into a loop of wire about 12 inches in diameter. Hold this radiating loop about 12 inches from and parallel to the receiver loop antenna. Advance the output of the signal generator until deflection is obtained on the output meter. Adjust first the oscillator trimmer (on front section of variable condenser) then the antenna trimmer (on rear section of variable condenser) for maximum response.

If the loop antenna has been replaced it may be necessary to adjust the loop inductance as follows. Align at 140. Set the pointer at 60 and feed 600 kc to the antenna lead. A portion of the outside turn of the loop may be swung to either side of the center to give maximum response. Realign at 140.

Schematic Symbol	†Part No.	DESCRIPTION
C5, C15, C20	920010	0.002 mfd., 600 volt condenser
C6, C18	920060	0.05 mfd., 200 volt condenser
C7, C19	910010	0.00011 mfd., mica condenser
C12, C17	910000	0.00022 mfd., mica condenser
C13, C14	920020	0.02 mfd., 400 volt condenser
C21, C22	920030	0.05 mfd., 400 volt condenser
C23, C24	925110	30-50 mfd., 150 volt dual electrolytic condenser (chassis 120006), or
C23, C24	925011	50-50 mfd., 150 volt dual electrolytic condenser (chassis 120056)
C25	920050	0.2 mfd., 200 volt condenser
L1	700010	Loop antenna
L2	708060	455 kc wave trap
R1	310730	10,000 ohms, ¼ watt resistor
R2, R6	310810	22,000 ohms, ¼ watt resistor
R3	310870	39,000 ohms, ¼ watt resistor
R4, R14	397000	15 meg. ¼ watt resistor
R5, R10, R11	321130	470,000 ohms, ¼ watt resistor
R7	321330	3.3 meg., ¼ watt resistor
*R8		47,000 ohms resistor, part of i-f transformer
R9	390180	0.5 meg. volume control
R12	340290	150 ohms, ½ watt resistor
R13	370490	1,000 ohms, 1 watt resistor
R15	340050	15 ohms, ½ watt resistor
R16	340010	10 ohms, ½ watt resistor
R17	321050	220,000 ohms, ½ watt resistor

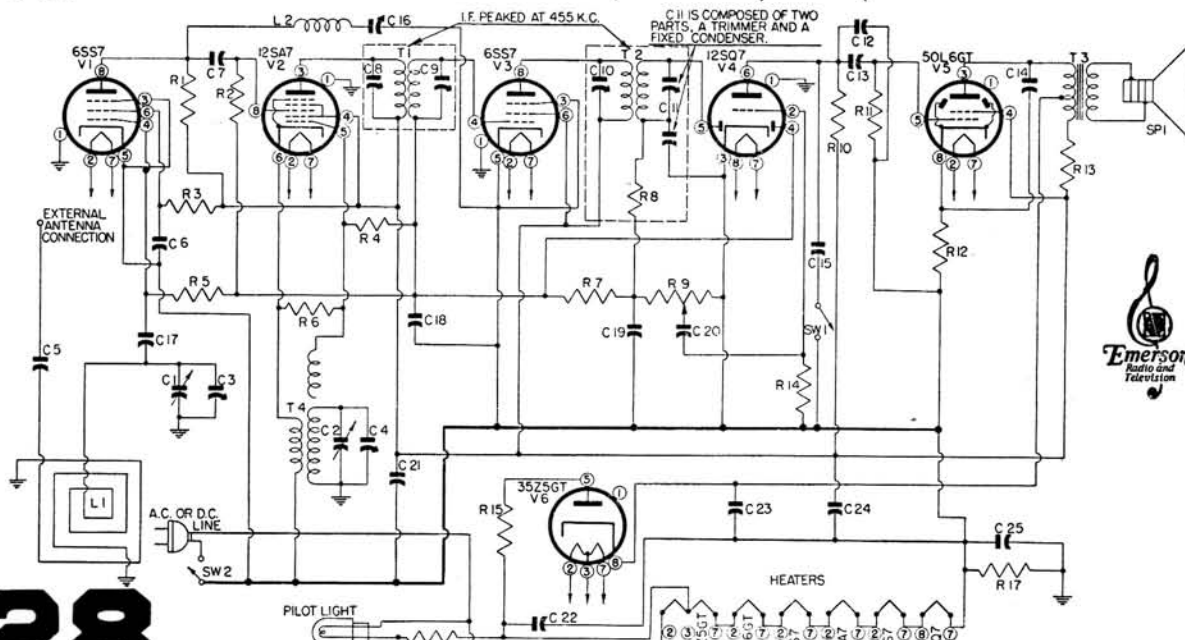

28

circuit diagram for chassis 120006. Substitute proper pin connections for loctal tubes on chassis 120056.

MANUAL OF 1948 MOST-OFTEN-NEEDED RADIO DIAGRAMS

Emerson Radio

MODELS: 514, 534

CHASSIS MODEL: 120007

An oscillator with frequencies of 455, 600, 1600 and 12,000 kc is required.

An output meter should be used across the voice coil or output transformer for observing maximum response.

Always use as weak a test signal as possible when aligning the receiver.

I-f Alignment

Swing the variable condenser to the minimum capacity position. Feed 455 kc to the grid of the 12SG7 tube through a 0.1 mfd. condenser and adjust the four i-f trimmers for maximum response.

Note: The grid of the 12SG7 tube is the No. 4 pin.

R-f Alignment

Rotate the wave-band switch counter-clockwise to the short-wave position. Set the dial pointer at 12 megacycles and using a 400 ohm carbon resistor as a dummy antenna

FREQUENCY RANGE:

540-1620 kc. (555-185 meters)

8.8-12.2 mc. (16.3-24.5 meters)

The color coding of the i-f transformer leads is as follows:
 Grid—green
 Grid return—black
 Plate—blue
 B+—red

feed 12 megacycles from the generator to the external antenna lead emerging from the rear of the chassis. Adjust first the short-wave oscillator trimmer and then the short-wave antenna trimmer for maximum response.

Rotate the wave-band switch clockwise to the broadcast position. Set the dial pointer at 160 and feed 1600 kc from the signal generator into a loop of wire about 12 inches in diameter. Hold this radiating loop about 12 inches from the loop antenna and advance the signal generator until a deflection is obtained on the output meter. Adjust first the oscillator trimmer (rear section of the variable condenser) and then the antenna trimmer (front section of the variable condenser) for maximum response.

If the loop has been replaced it may be necessary to adjust the loop inductance as follows: Align at 1600. Set the pointer at 60 and feed 600 kc into the radiating loop. A portion of the outside turn of the loop may then be swung to either side of the center to give maximum response. Re-align at 1600.

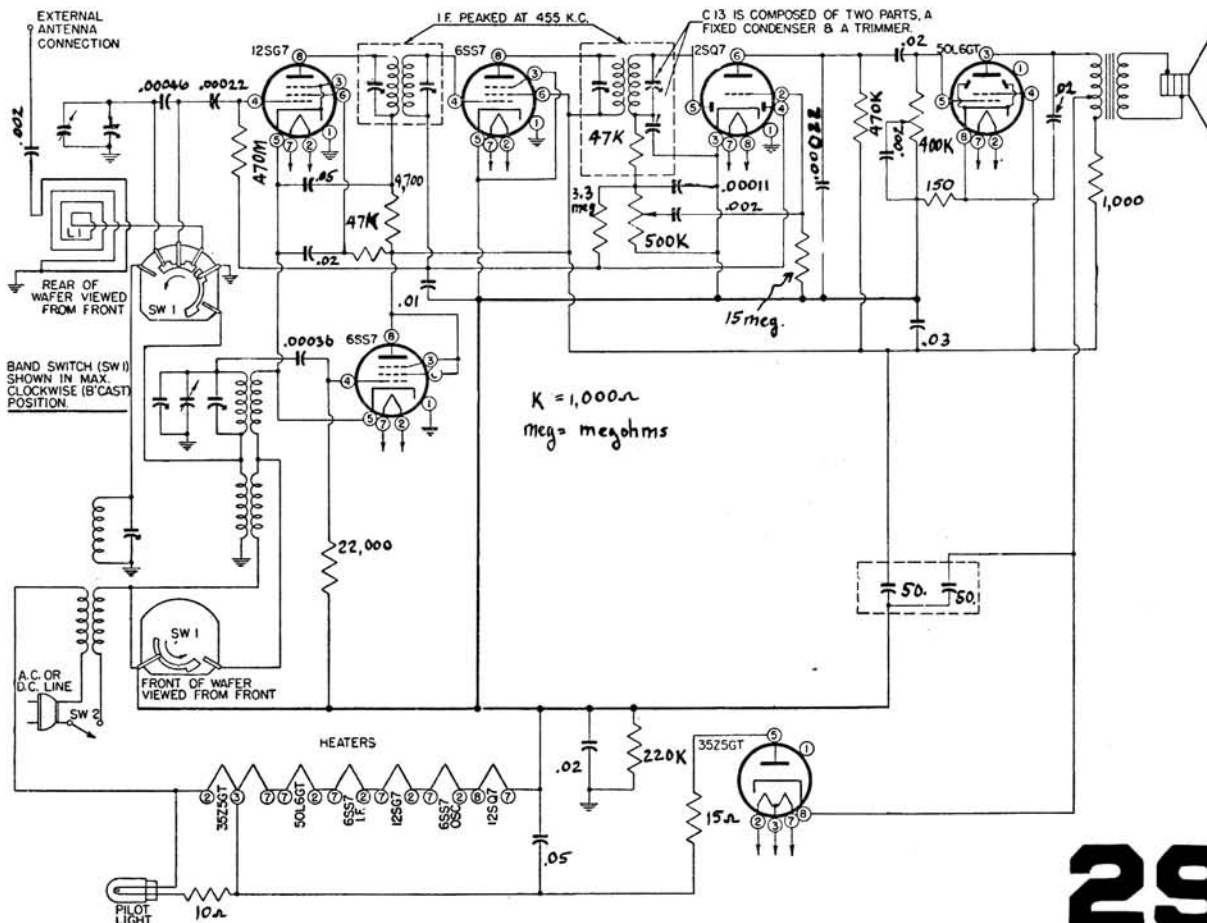

MANUAL OF 1948 MOST-OFTEN-NEEDED RADIO DIAGRAMS

Emerson Radio

MODELS: 531, 532, 533

CHASSIS MODEL: 120040

C11 IS COMPOSED OF TWO PARTS, A TRIMMER AND A FIXED CONDENSER.

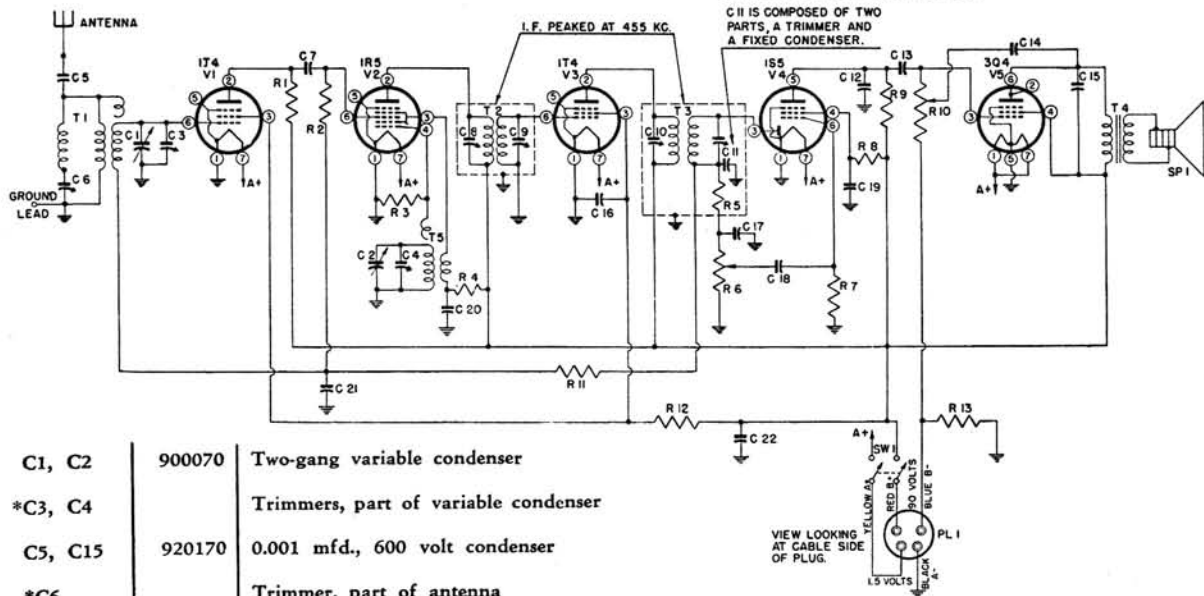

C1, C2	900070	Two-gang variable condenser	R2	321130	470,000 ohms, 1/4 watt resistor
*C3, C4		Trimmers, part of variable condenser	R3	320970	100,000 ohms, 1/4 watt resistor
C5, C15	920170	0.001 mfd., 600 volt condenser	*R5		47,000 ohms, 1/4 watt resistor, part of second i-f transformer
*C6		Trimmer, part of antenna transformer	R6	390180	0.5 meg. volume control
C7, C12	910000	0.00022 mfd. mica condenser	R7	321450	10 meg., 1/4 watt resistor
*C8, C9, C10		Trimmers, part of i-f transformer	R8, R11	321330	3.3 meg., 1/4 watt resistor
*C11		Trimmer and fixed condenser, part of second i-f transformer	R9	321210	1 meg., 1/4 watt resistor
C13, C16, C19, C20	920100	0.02 mfd., 200 volt condenser	R10	390280	0.4 meg. tone control
C14	910250	0.00005 mfd. mica condenser	R12	310770	15,000 ohms, 1/4 watt resistor
C17	910010	0.00011 mfd. mica condenser	R13	310410	470 ohms, 1/4 watt resistor
C18	920515	0.002 mfd., 400 volt condenser	SP1	180008	P.M. speaker
C21	920040	0.1 mfd., 200 volt condenser	SW1	510401	Battery switch, or
C22	925003	16 mfd., 150 volt electrolytic condenser	SW1	510001	Battery switch
PL1	585311	Battery plug and cable assembly, or	T1	710001	Antenna transformer and trap
PL1	585312	Battery plug and cable assembly			
R1, R4	310730	10,000 ohms, 1/4 watt resistor			

The following voltage readings are d-c measurements from tube socket pin to chassis. A 1000 ohms-per-volt meter should be used for all readings except those indicated by an asterisk (*), which should be taken with a d-c vacuum-tube voltmeter. All voltages are positive unless otherwise indicated.

TUBE	PIN NUMBER						
	1	2	3	4	5	6	7
1T4(V1)		55	52	82		*-3	1.5
1R5		82	57	*-11.0		*-4	1.5
1T4(V3)		82	52			*-4	1.5
1S5		-6.2	*-45	*18	10	*-3	1.5
3Q4		80.0	*-6.2	82	1.5	80	

MANUAL OF 1948 MOST-OFTEN-NEEDED RADIO DIAGRAMS

TUBE	PIN NUMBER							
	1	2	3	4	5	6	7	8
12SA7			89	89	*-10			*-1.6
12SK7				*-1.6		89		89
12SQ7		*-0.7		*-1.6	-0.5	37.5		
50L6GT			110	89				6.2
35Z5GT				116		116		117

The following voltage readings are d-c measurements taken from B— (line switch) to the indicated tube-socket pin. A 1000 ohms-per-volt meter should be used for all readings except those indicated by an asterisk (*), which should be taken with a d-c vacuum-tube voltmeter. Line voltage for these readings was 117 volts, 60 cycles, a.c. Take readings with the volume control set at minimum and the variable condenser closed.

EMERSON RADIO MODELS: 525, 552

CHASSIS MODEL: 120037

C1, C2	900290	Two-gang variable condenser
*C3, C4		Trimmers, part of variable condenser
*C5, C6, C7, C8		Trimmers, part of i-f transformers
C9	910000	0.00022 mfd. mica condenser
C10	920010	0.002 mfd., 600 volt condenser
C11	920515	0.002 mfd., 400 volt condenser
C12	920240	0.0005 mfd., 600 volt condenser
C13, C14	920020	0.02 mfd., 400 volt condenser
C15	920040	0.1 mfd., 200 volt condenser
C16	920050	0.2 mfd., 200 volt condenser (used only when T1 and T2 are 720000 and 720100 respectively)
C17, C19	920030	0.05 mfd., 400 volt condenser
C18	922090	0.05 mfd., 400 volt condenser (used up to serial No. 8,550,551), or
C18	922101	0.05 mfd., 400 volt condenser (used after serial No. 8,550,551)
C20, C21	925267	30-50 mfd., 150 volt dual electrolytic

R1	310810	22,000 ohms, 1/4 watt resistor
R2, R4	397000	15 meg., 1/2 watt resistor
R3	321330	3.3 meg., 1/4 watt resistor
R5	390010	0.5 meg. volume control
R6, R7	321130	470,000 ohms, 1/4 watt resistor
R8	340290	150 ohms, 1/2 watt resistor
R9	321290	2.2 meg., 1/4 watt resistor
R10	370490	1,000 ohms, 1 watt resistor
R11	321050	220,000 ohms, 1/4 watt resistor
R12	321210	1 meg., 1/4 watt resistor
R13	340010	10 ohms, 1/2 watt resistor
R14	340050	15 ohms, 1/2 watt resistor
SP1	180000	P.M. speaker
SW1	510130	Tone control switch
SW2	510390	Phono-radio switch
*SW3		Motor switch, part of record changer
*SW4		Line switch on volume control

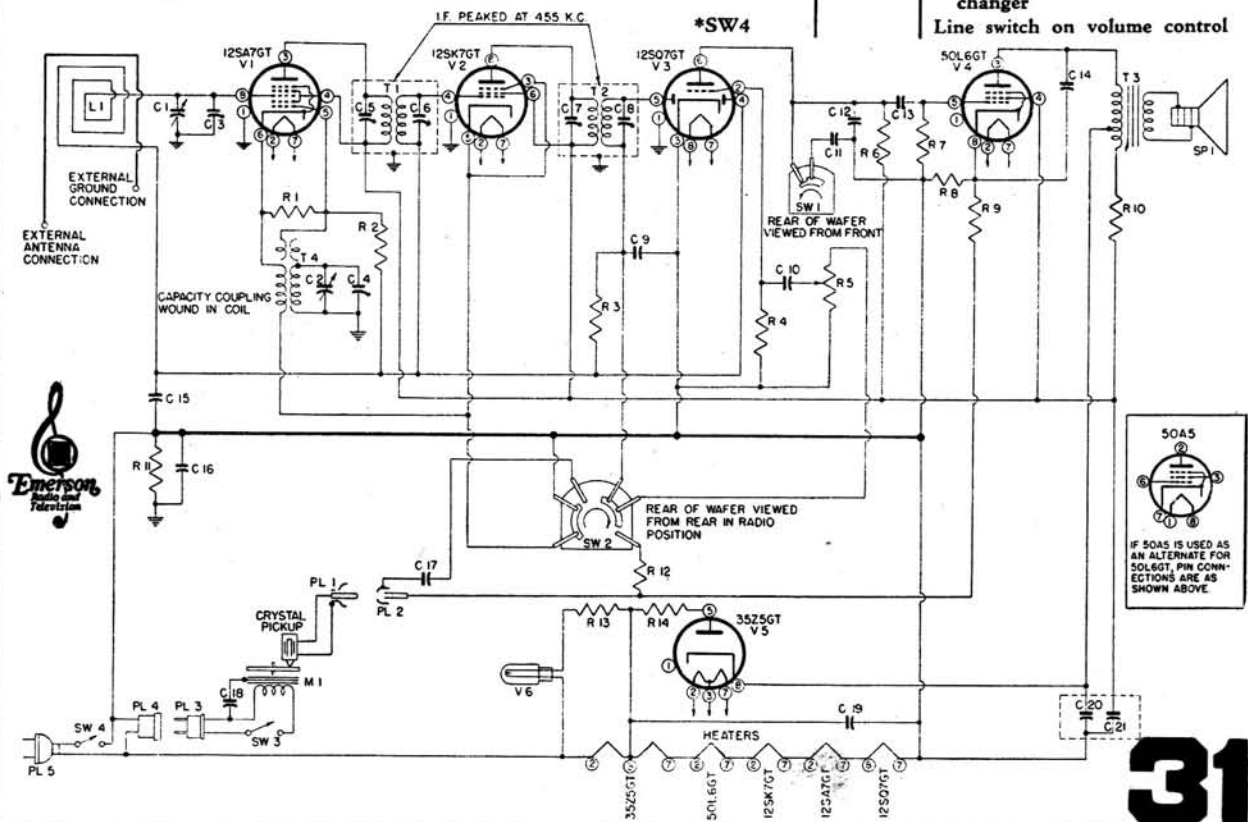

MANUAL OF 1948 MOST-OFTEN-NEEDED RADIO DIAGRAMS

Emerson Radio

Models 536A,
551A, 553A
Chassis 120036

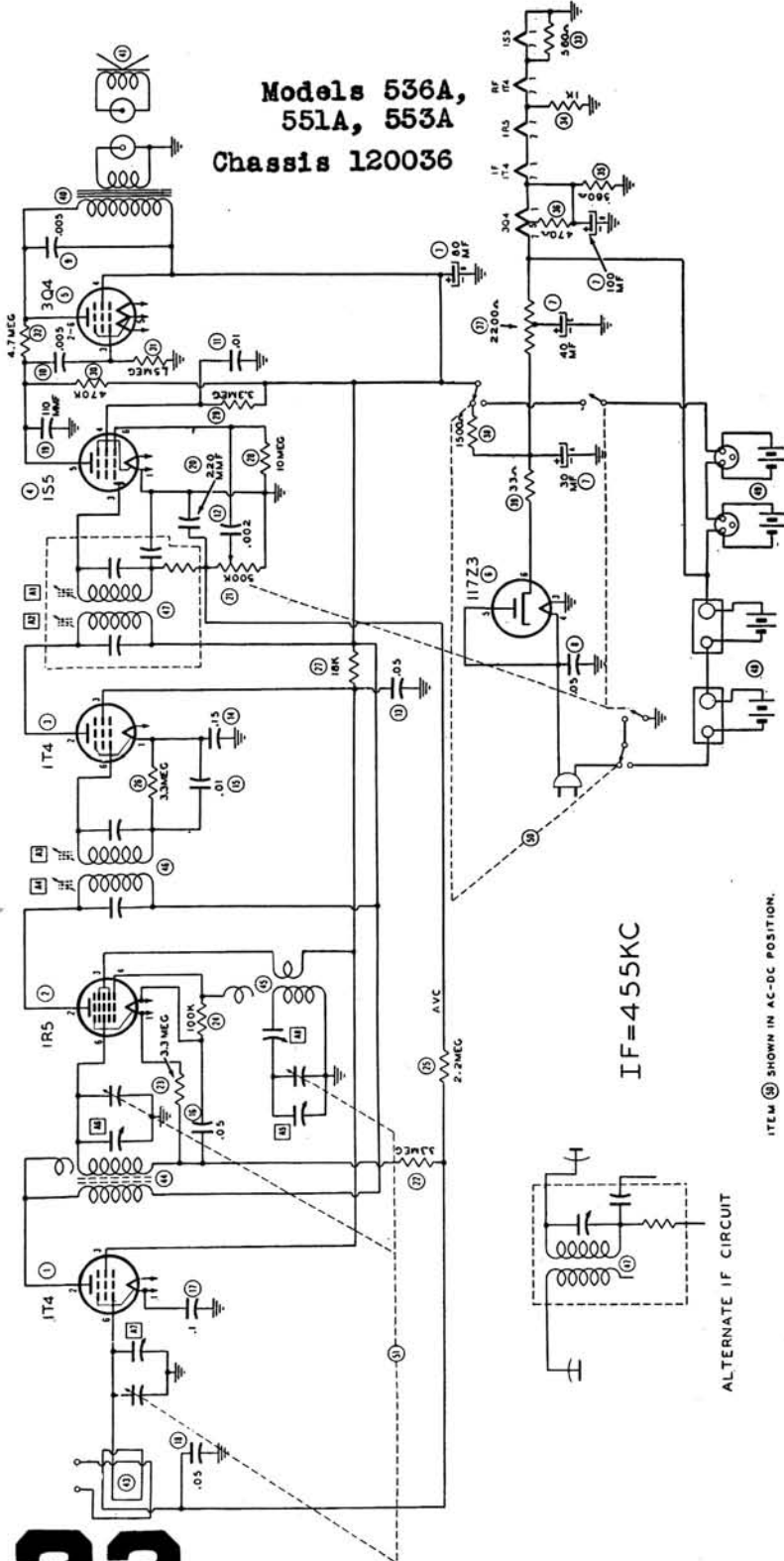

ITEM (R) SHOWN IN AC-DC POSITION.

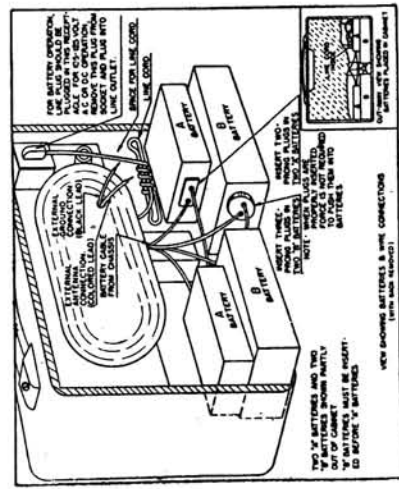
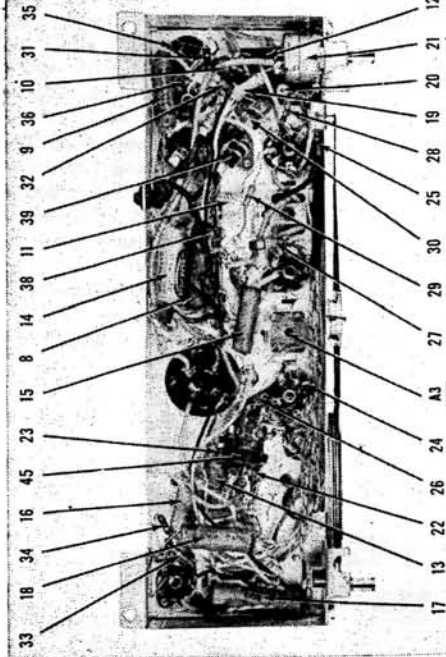
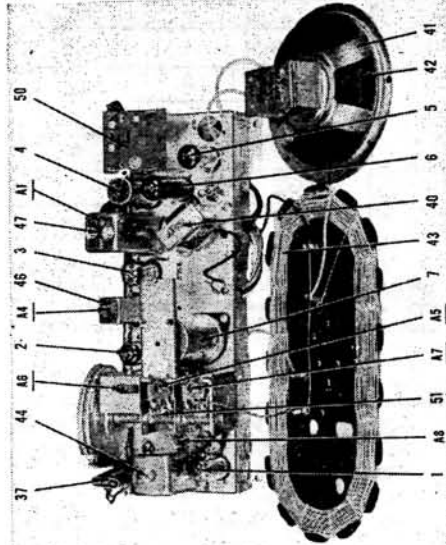

MANUAL OF 1948 MOST-OFTEN-NEEDED RADIO DIAGRAMS

Emerson Radio R-f Alignment

Models 543, 544
Chassis 120046, 120052

Chassis 120046 below,
120052 next page.

I-f Alignment

1. Rotate the variable condenser to the minimum capacity position.
2. Feed 455 kc to the converter grid (stator of the r-f section of the variable condenser) through a 0.1 mfd. condenser and adjust the four i-f trimmers for maximum response.

1. Connect the oscillator to a coil composed of three to four turns of wire wound in a circle approximately 12" in diameter. This coil should be held parallel to and in line with the loop antenna of the receiver at a distance of 15 to 20 inches.
2. Radiate a signal at 1425 kc, set the dial indicator to 1425 kc, and adjust the trimmers on the variable condenser for maximum response.
3. Radiate a 600 kc signal and tune in the signal on the receiver. Adjust the loose outside turn of the loop antenna for maximum response. This loose turn may be moved to either side of the center. Fasten it in the position which gives maximum response.
4. Repeat steps 2 and 3 until no further improvement is evident.

C1, C2	900013	Two-gang variable condenser	R2, R6	397000	15 meg., 1/2 watt resistor
*C3, C4		Trimmers, part of variable condenser	R3	340310	180 ohms, 1/2 watt desistor
*C5, C6, C7, C8 }		Trimmers, part of i-f transformers	R4	321290	2.2 meg., 1/4 watt resistor
C9	920040	0.1 mfd., 200 volt condenser	R5	390015	0.5 meg. volume control
C10	910000	0.00022 mfd. mica condenser	R7, R8	321130	470,000 ohms, 1/4 watt resistor
C11	920010	0.002 mfd., 600 volt condenser	R9	340290	150 ohms, 1/2 watt resistor
C12	920240	0.0005 mfd., 600 volt condenser	R10	370490	1,000 ohms, 1 watt resistor
C13, C14	920020	0.02 mfd., 400 volt condenser	R11	321050	220,000 ohms, 1/4 watt resistor
C15	920050	0.2 mfd., 200 volt condenser (used when T1 and T2 are 720000, and 720100 respectively), or	R12	340050	15 ohms, 1/2 watt resistor
			R13	340010	10 ohms, 1/2 watt resistor
C15	470199	0.2 mfd., 200 volt assembly (used when T1 and T2 are 720525 and 720529 respectively)	SP1	180000	P.M. speaker
C16	920030	0.05 mfd., 400 volt condenser	*SW1		Line switch on volume control
C17, C18	925009	50-50 mfd., 150 volt dual electrolytic condenser	T1	720000	First i-f transformer, or
L1	700000	Loop antenna	T1	720525	First i-f transformer, midget
*PL1		Power plug, part of line cord	T2	720100	Second i-f transformer, or
R1	310810	22,000 ohms, 1/4 watt resistor	T2	720529	Second i-f transformer, midget
			T3	734000	Output transformer
			T4	716010	Oscillator coil
				583010	Pilot light
				807000	Line cord
				507090	Pilot light socket

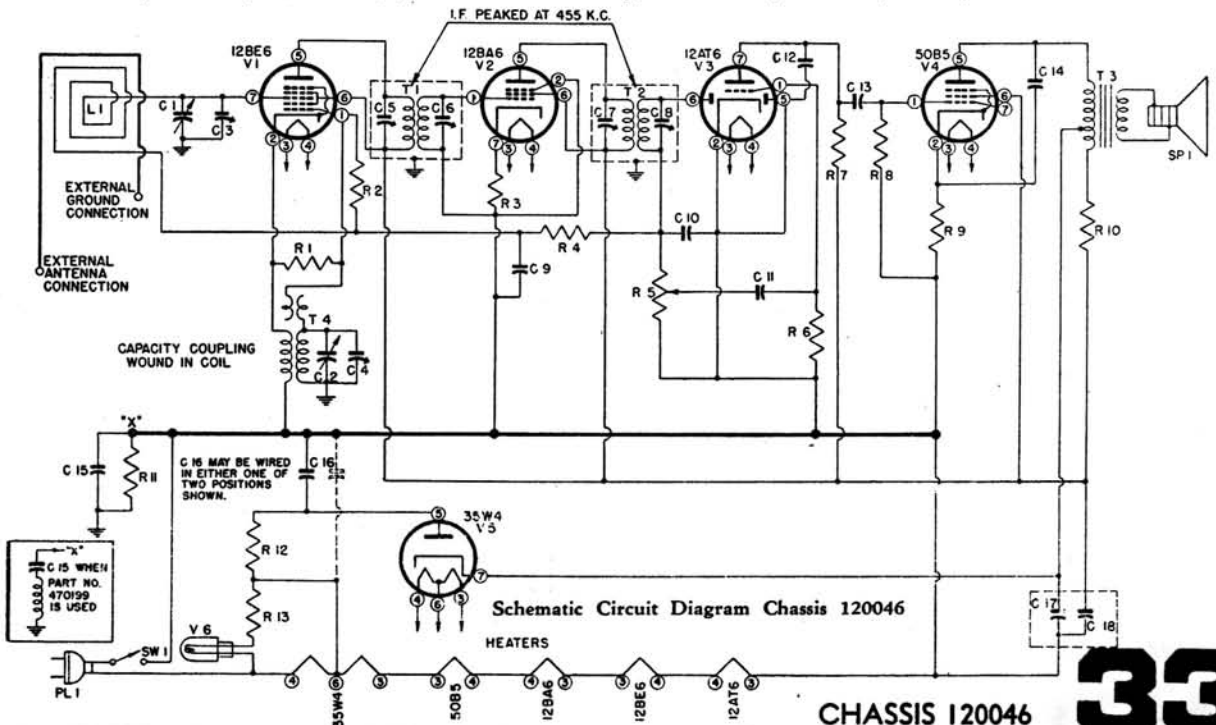

MANUAL OF 1948 MOST-OFTEN-NEEDED RADIO DIAGRAMS

Emerson Radio, Models 543, 544, Chassis 120052

See also preceding page for 120046

The following voltage readings are d-c measurements taken from B— (line switch) to the indicated tube-socket pin. A 1000 ohms-per-volt meter should be used for all readings except those indicated by an asterisk (*), which should be taken with a d-c vacuum-tube voltmeter. Line voltage for these readings was 117 volts, 60 cycles, a.c. Measurements made with 117 volts d.c. will be lower than those given below. Take readings with the volume control set at minimum and the variable condenser closed.

TUBE	PIN NUMBER							
	1	2	3	4	5	6	7	8
12SA7			89	89	*—10			*—1.6
12SK7				*—1.6		89		89
12SQ7		*—0.7		*—1.6	—0.5	37.5		
50L6			110	89				6.2
35Z5				116		116		117
12BE6	*—80				92	92	*—1.3	
12BA6					92	92	1.7	
12AT6	*—0.6					*—0.45	*44	
50B5		5.65			110	92		
35W4	115						115	

Schematic Symbol	†Part No.	DESCRIPTION	Schematic Symbol	†Part No.	DESCRIPTION
C1, C2	900160	Two-gang variable condenser	R3	390015	0.5 meg. volume control
*C3, C4		Trimmer, part of variable condenser	R4, R5	321130	470,000 ohms, ¼ watt resistor
*C5, C6, {		Trimners, part of i-f transformers	R6	340290	150 ohms, ½ watt resistor
C7, C8 }			R7	370490	1000 ohms, 1 watt resistor
C9, C15	920010	0.002 mfd., 600 volt condenser	R8	310810	22,000 ohms, ¼ watt resistor
C10	920240	0.0005 mfd., 600 volt condenser	R10	340010	10 ohms, ½ watt resistor
C11, C12	920020	0.02 mfd., 400 volt condenser	R11	397040	15 ohms, 1 watt wire-wound resistor
C13	910000	0.00022 mfd. mica condenser	R12	321050	220,000 ohms, ¼ watt resistor
C14	520040	0.1 mfd., 200 volt condenser	SP1	180000	P.M. speaker
C16	920030	0.05 mfd., 400 volt condenser	*SW1		Line switch on volume control
C17, C18	925000	30-50 mfd., 150 volt dual electrolytic condenser	T1	720000	First i-f transformer
C19	920050	0.02 mfd., 200 volt condenser	T2	720100	Second i-f transformer
L1	700000	Loop antenna, or	T3	734000	Output transformer
L1	700200	Loop antenna	T4	716010	Oscillator coil
R1, R9	397000	15 meg., ¼ watt resistor		583010	Line cord
R2	321330	3.3 meg., ¼ watt resistor		807000	Pilot light
				507090	Pilot light socket

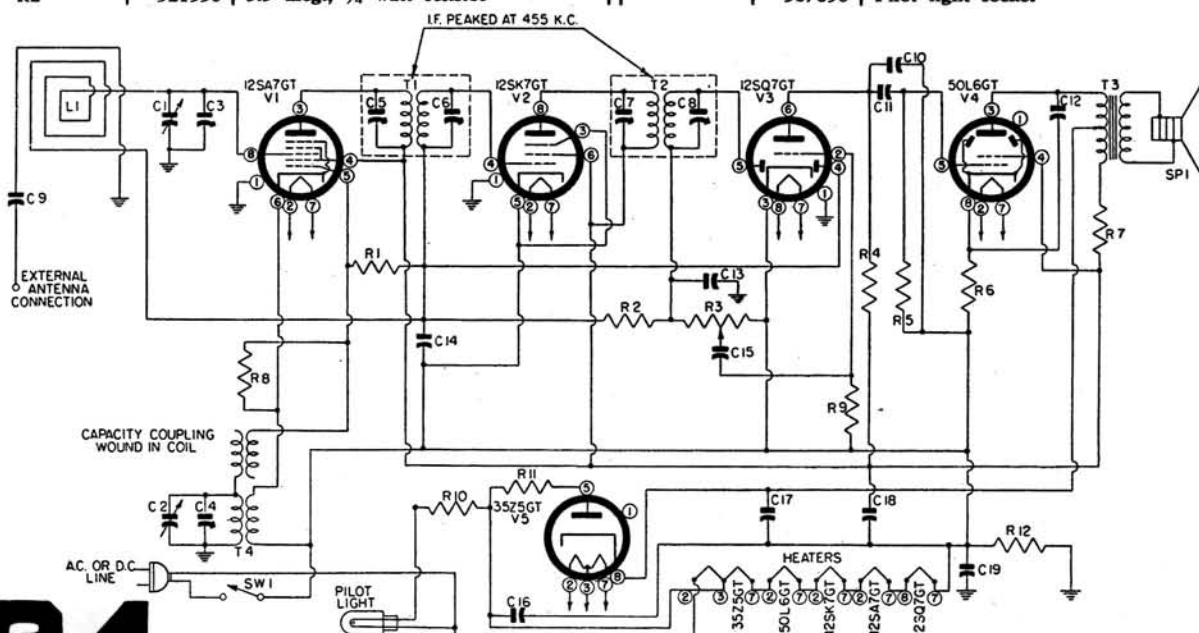

Schematic Circuit Diagram Chassis 120052

MANUAL OF 1948 MOST-OFTEN-NEEDED RADIO DIAGRAMS

Emerson Radio

MODEL: 547A

CHASSIS MODEL: 120050A

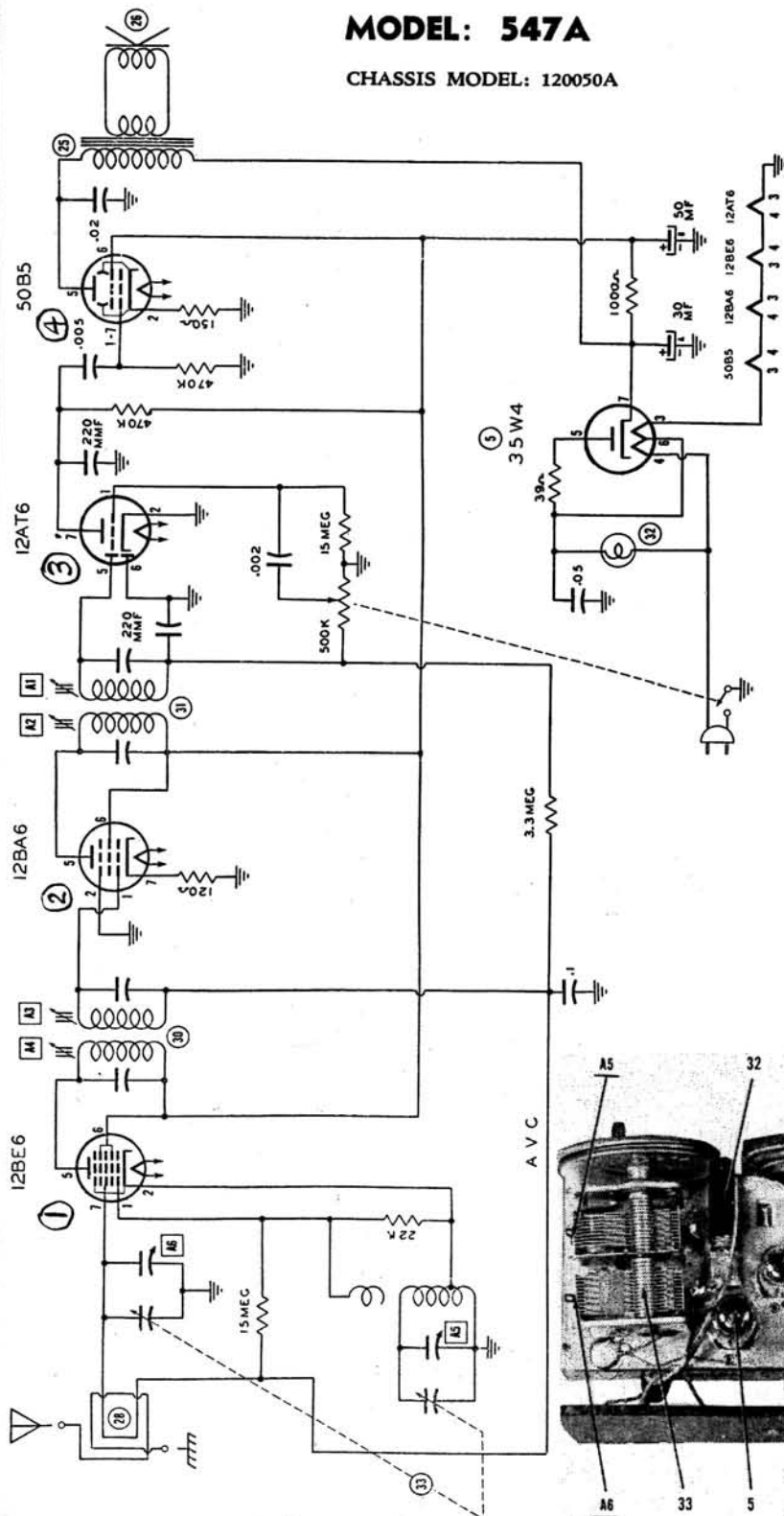

	DUMMY ANTENNA	SIGNAL GENERATOR COUPLING	SIGNAL GENERATOR FREQUENCY	RADIO DIAL SETTING	METER OUTPUT	ADJUST	REMARKS
1	0.1 mfd.	High side to stator of rear section of tuning condenser. Low side to chassis.	455 kc	Variable condenser fully open.	Across voice coil.	A1, A2, A3, A4	Adjust for maximum output. If isolation transformer is not used, reduce dummy antenna to 0.001 mfd. to reduce hum modulation.
2	200 mmfd.	High side to external antenna lead. Low side to external ground lead.	1620 kc	Variable condenser fully open.	Across voice coil.	A5	Adjust for maximum output.
3	200 mmfd.	High side to external antenna lead.	1400 kc	Tune for maximum output.	Across voice coil.	A6	Adjust for maximum output.

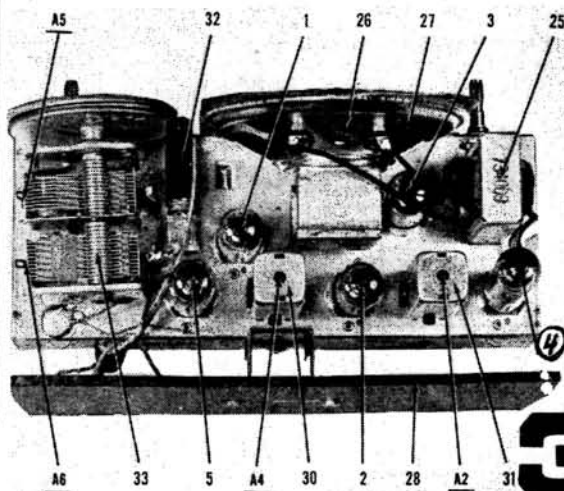

MANUAL OF 1948 MOST-OFTEN-NEEDED RADIO DIAGRAMS

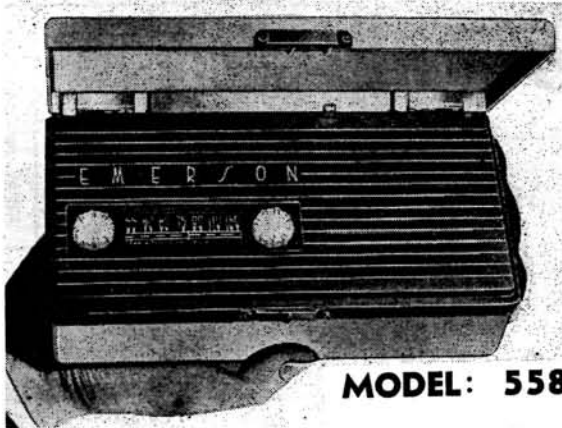

MODEL: 558

CHASSIS MODEL: 120058

Schematic Symbol	†Part No.	DESCRIPTION
C1, C2	900022	Two-gang variable condenser
*C3, C4		Trimmers, part of variable condenser
*C5, C6		Trimmers, part of first i-f transformer
*C7, C8		Trimmers, part of second i-f transformer
C9, C14	928013	100 mmfd., ceramic condenser
C10, C13	920495	0.001 mfd., 200 volt condenser
C11	920496	0.005 mfd., 200 volt condenser
C12	928104	212 mmfd., ceramic condenser
C15	920494	0.05 mfd., 200 volt condenser
C16	920120	0.02 mfd., 100 volt condenser
C17	925063	16 mfd., 100 volt electrolytic condenser
C18	920485	0.01 mfd., 100 volt condenser
L1	700008	Loop antenna
R1	350970	100,000 ohms, ½ watt resistor
R2	340470	820 ohms, ½ watt resistor
R3	390025	1 meg., volume control
R4	351450	10 meg., ½ watt resistor
R5, R9	351330	3.3 meg., ½ watt resistor
R6	351130	470,000 ohms, ½ watt resistor
R7	351250	1.5 meg., ½ watt resistor
R8	340730	10,000 ohms, ½ watt resistor
SP1	180029	Speaker, 3-inch P.M.
T1	720028	First i-f transformer, or
T1	720034	First i-f transformer
T2	720028	Second i-f transformer, or
T2	720035	Second i-f transformer
T3	734011	Output transformer
T4	716011	Oscillator coil

The first i-f transformer is located next to the 1R5 tube. The trimmers are accessible through holes in the top of the can.

The second i-f transformer is located between the 1T4 and 1S5 tubes. The single trimming core screw extends from the end of the can. Trimmers are accessible through holes in the top of the can.

The oscillator coil is located behind the on-off switch. The trimmer for the oscillator is located on the smaller variable condenser section. The 600 kc oscillator core adjustment is the brass screw protruding from the end of the oscillator coil.

I-f Alignment

1. Rotate the variable condenser to the minimum capacity position.
2. Feed 455 kc to the grid (pin 6) of the 1R5 tube through a 0.01 mfd. condenser.
3. Adjust the four i-f trimmer screws for maximum response. (Clip the test signal lead to the stator of the larger capacity section of the variable condenser.)

R-f Alignment

1. Connect the test oscillator to a coil composed of three or four turns of wire wound in a circle approximately 12 inches in diameter. This coil should be placed parallel to and in line with the receiver loop at a distance of approximately 15 to 20 inches.
2. Radiate a signal at 1620 kc, rotate the variable condenser to minimum capacity, and adjust the oscillator trimmer, on the smaller section of the variable condenser, for maximum response.
3. Radiate a signal at 1420 kc, tune in the 1420 kc signal, and adjust the antenna trimmer, on the larger section of the variable condenser, for maximum response.
4. Radiate a signal at 600 kc, set the dial indicator to 60, and adjust the oscillator coil core trimmer while rocking the variable condenser for maximum response.
5. Return to 1620 kc and check alignment. If readjustment is necessary, repeat Steps 2 to 4 until no further improvement is noted.

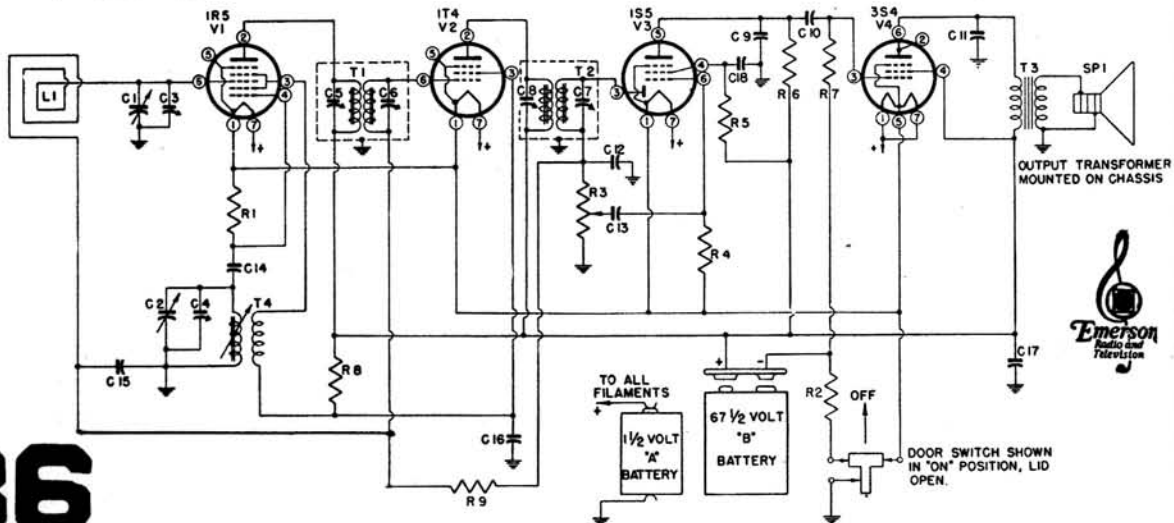

MANUAL OF 1948 MOST-OFTEN-NEEDED RADIO DIAGRAMS

Emerson Radio

MODEL: 548 549

CHASSIS MODEL: 120051

To replace tubes, remove the two knobs and unscrew the four red screws holding the chassis support to the cabinet at the bottom. Lift the board and chassis out and set it aside.

Normally, the record changer should not require additional lubrication. A drop of machine oil on the turntable shaft bearings, motor bearings, and frictional surfaces once a year will do no harm. Do not lubricate the trip mechanism or allow oil to come in contact with the idler wheel.

C1	920170	0.001 mfd., 600 volt condenser
C2	920020	0.02 mfd., 400 volt condenser
C3, C6	920030	0.05 mfd., 400 volt condenser
C4	910010	0.00011 mfd. mica condenser, or
C4	910220	0.0001 mfd. mica condenser
C5	910000	0.00022 mfd. mica condenser, or
C5	910230	0.0002 mfd. mica condenser
C8, C9	925009	50-50 mfd., 150 volt dual electrolytic condenser
C10	920420	0.15 mfd., 200 volt condenser
R1	390016	0.5 meg. volume control
R2	397000	15 meg., ½ watt resistor
R3, R4	351130	470,000 ohms, ½ watt resistor
R5	370290	150 ohms, 1 watt resistor
R6	340430	560 ohms, ½ watt resistor
R8	390370	2 meg. tone control
R9	340050	15 ohms, ½ watt resistor
R10	394160	133 ohms, 5 watt resistor

The following voltage readings are d-c measurements taken from B— (line switch) to the indicated tube-socket pin. A 1000 ohms-per-volt meter should be used for all readings except those indicated by an asterisk (*), which should be taken with a d-c vacuum-tube voltmeter. Line voltage for these readings was 117 volts, 60 cycles, a-c.

TUBE	PIN NUMBER						
	1	2	3	4	5	6	7
12AT6	*-0.7						45
50B5		7.8			118	123	
35W4	128						128

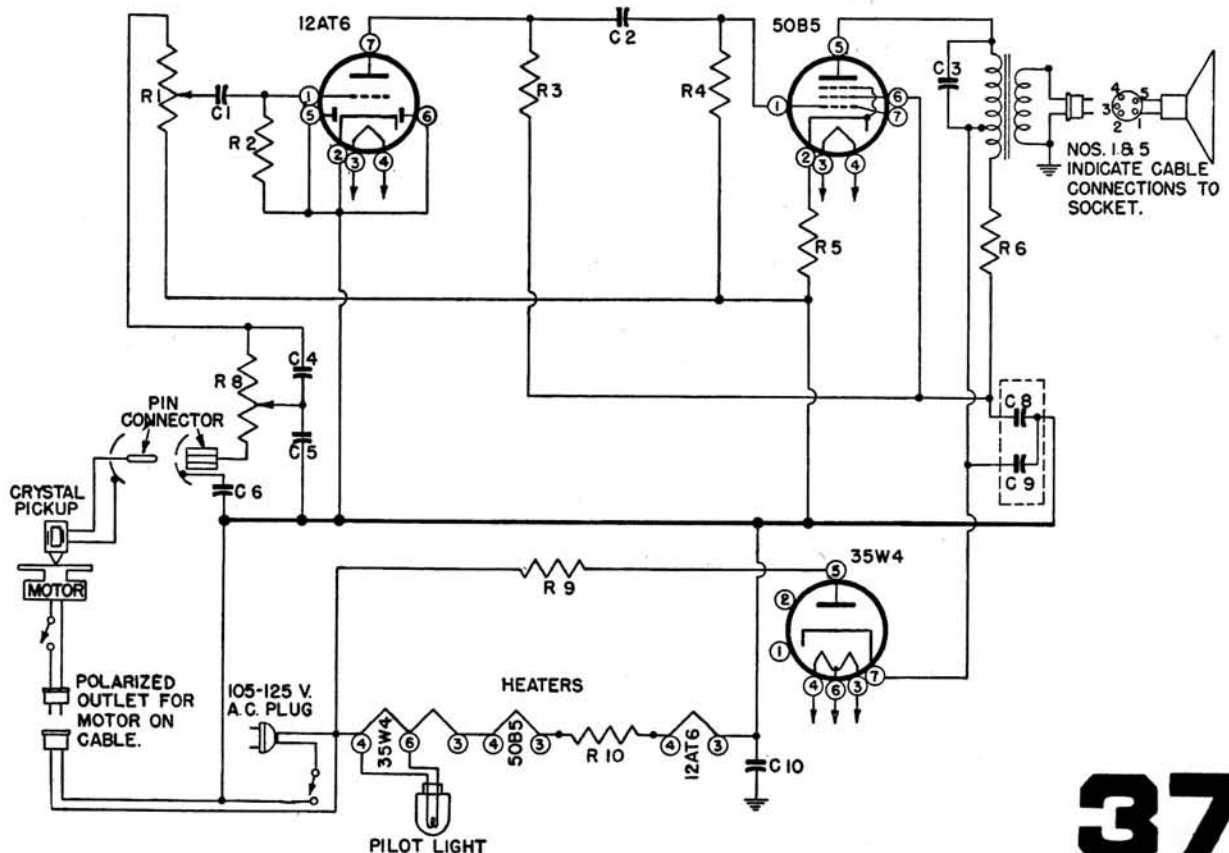

MANUAL OF 1948 MOST-OFTEN-NEEDED RADIO DIAGRAMS

EMERSON RADIO

MODELS: 1002, 1003

CHASSIS MODEL: 129003

The second i-f transformer (T2) is mounted on top of the chassis to the right of the speaker. The trimmers (C7, C8) are accessible through holes in the top of the can.

The trimmer for the antenna (C3) and the trimmer for the oscillator coil (C4) are located on the variable condenser. The trimmer on the front section is for the oscillator coil.

I-f Alignment

1. Rotate the variable condenser to the minimum capacity position.
2. Feed 455 kc to the converter grid (stator of the r-f section of the variable condenser) and adjust the four i-f trimmers (C5, C6, C7, C8) for maximum response.

R-f Alignment

1. Connect the oscillator to a coil composed of three or four turns of wire wound in a circle approximately 12" in diameter. This coil should be held parallel to and in line with the loop antenna of the receiver at a distance of 15 to 20 inches.
2. Radiate a signal at 1425 kc, set the dial indicator to 1425 kc, and adjust the trimmers on the variable condenser (C3, C4) for maximum response.
3. Radiate a 600 kc signal and tune in the signal on the receiver. Adjust the loose outside turn of the loop antenna for maximum response. This loose turn may be moved to either side of the center. Fasten it in the position which gives maximum response.
4. Repeat steps 2 and 3 until no further improvement is evident.

Schematic Symbol	†Part No.	DESCRIPTION
C1, C2	900070	Two-gang variable condenser
*C3, C4		Trimmers, part of variable condenser
*C5, C6, { C7, C8 }		Trimmers, part of i-f transformers
C9, C15, { C20, C25 }	920010	0.002 mfd., 600 volt condenser
C10	920240	0.0005 mfd., 600 volt condenser
C11, C12, { C21 }	920020	0.02 mfd., 400 volt condenser
C13	920040	0.1 mfd., 200 volt condenser
C14	910010	0.00011 mfd. mica condenser
C16	920050	0.2 mfd., 200 volt condenser
C17, C24	920030	0.05 mfd., 400 volt condenser
C18, C19	925011	50-50 mfd., 150 volt dual electrolytic condenser
C22	920060	0.05 mfd., 200 volt condenser
C23	925180	10 mfd., 25 volt electrolytic condenser
L1	700000	Loop antenna
R1	340810	22,000 ohms, ½ watt resistor
R2, R9	397000	15 meg., ½ watt resistor
R3, R4	351130	470,000 ohms, ½ watt resistor
R5	340290	150 ohms, ½ watt resistor
R6	370490	1000 ohms, 1 watt resistor
R7, R14	351330	3.3 meg., ½ watt resistor
R8	390190	0.5 meg. volume control
R10	351050	220,000 ohms, ½ watt resistor
R11	340010	10 ohms, ½ watt resistor
R12	340050	15 ohms, ½ watt resistor
R13	390180	0.5 meg. volume control (sets below 8,767,450), or
R13	390014	2 meg. volume control (sets 8,767,450 and higher)
R15	340410	470 ohms, ½ watt resistor
R16	351050	220,000 ohms, ½ watt resistor (sets below 8,767,450), or
R16	340970	100,000 ohms, ½ watt resistor (sets 8,767,450 and higher)

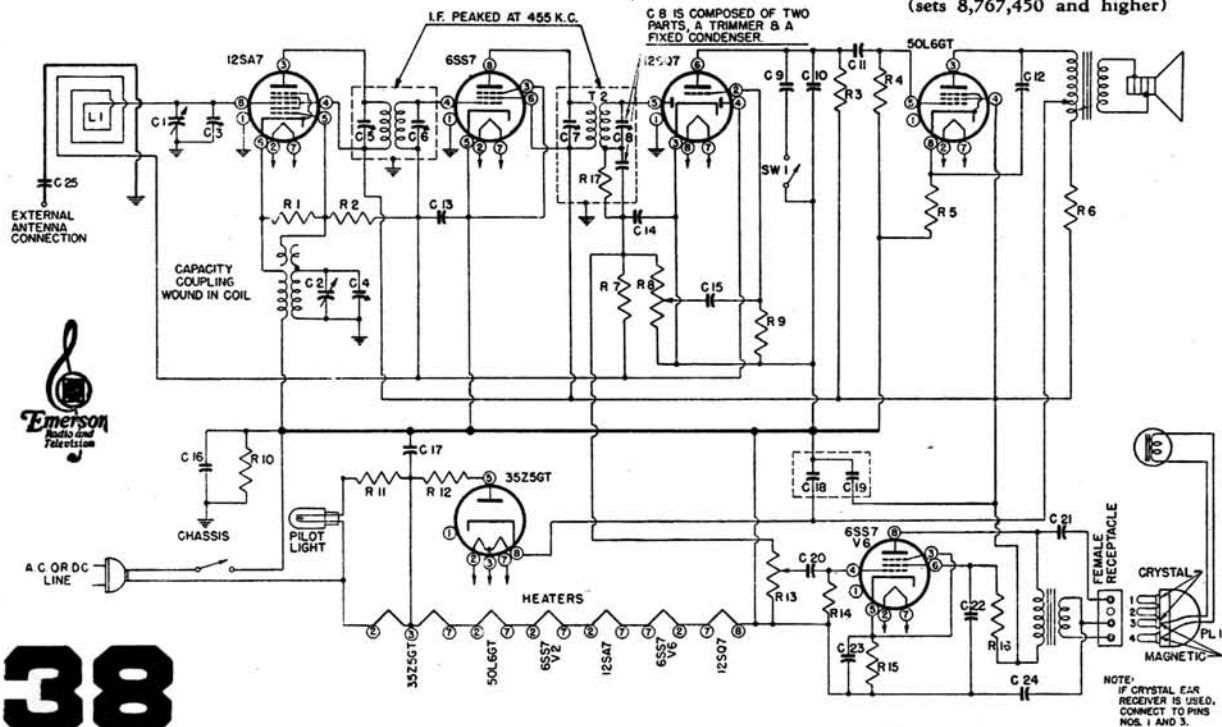

MANUAL OF 1948 MOST-OFTEN-NEEDED RADIO DIAGRAMS

Emerson

MODEL: 560

CHASSIS MODEL: 120016

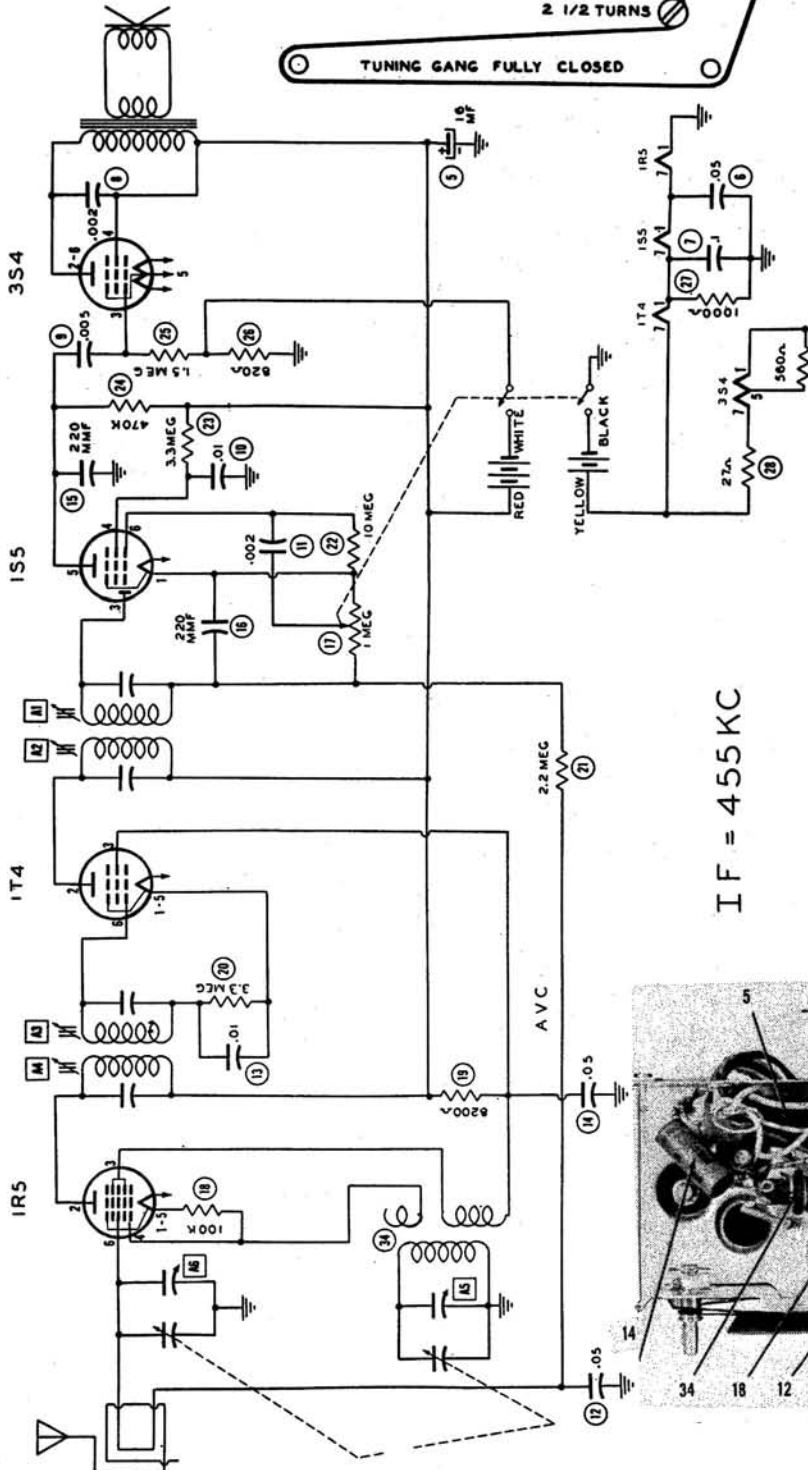

IF = 455 KC

To set pointer, turn variable condenser fully closed and set pointer at mark near left end of dial backplate. Connect a 100,000 ohm resistor across the loop leads during Steps 1 and 2. Volume control should be at maximum position; output of signal generator should be no higher than necessary to obtain an output reading. Use an insulated alignment screwdriver for adjusting.

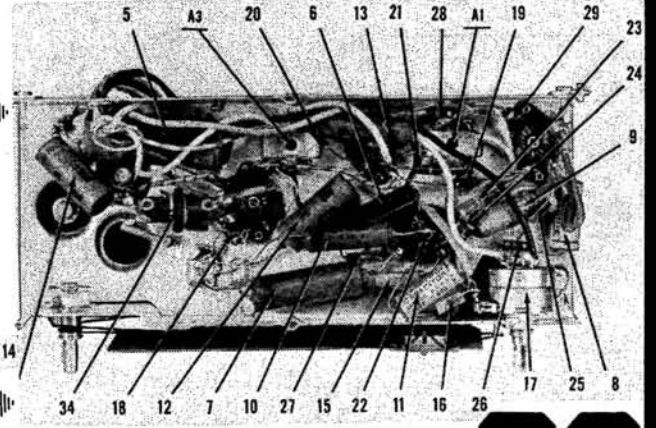

	DUMMY ANTENNA	SIGNAL GENERATOR COUPLING	SIGNAL GENERATOR FREQUENCY	RADIO DIAL SETTING	OUTPUT METER	ADJUST	REMARKS
1	0.1 mfd.	High side to rear stator of variable condenser. Low side to chassis.	455 kc	Variable condenser fully open.	Across voice coil.	A1, A2, A3, A4	Adjust for maximum output.
2	0.1 mfd.	High side to rear stator of variable condenser. Low side to chassis.	1620 kc	Variable condenser fully open.	Across voice coil.	A5	Adjust for maximum output.
3		Loop	1400 kc	Tune for maximum output.	Across voice coil.	A6	Disconnect 100,000 ohm resistor from loop leads. Connect loop leads to loop. Hold chassis in same relative position

MANUAL OF 1948 MOST-OFTEN-NEEDED RADIO DIAGRAMS

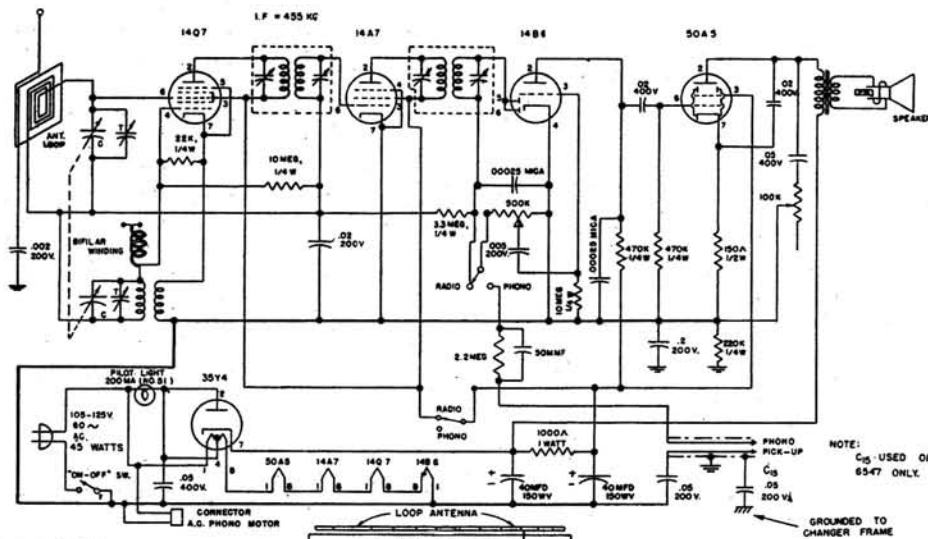

TUBE COMPLEMENT

TUBE	LOCTAL	OCTAL	MINIATURE
V ₁	14Q7		12BE6
V ₂	14A7		12BA5
V ₃	14BE		12AT5
V ₄	50A5	50L6	50B5
V ₅	35Y4		35W4

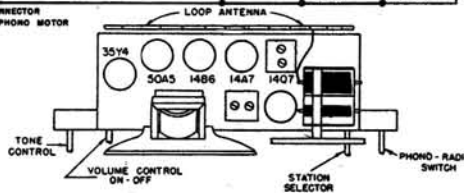

Espey Mfg. Co.
Models
20516A,
and 6547.

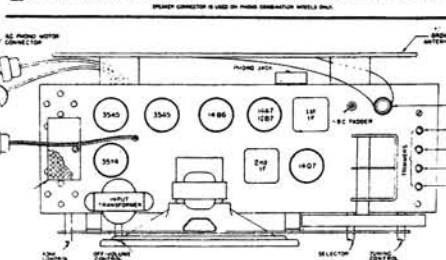
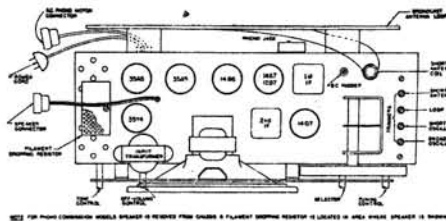

Steps	Connect output of Generator to	Tune Osc. to	Band Switch on	Tune Radio Dial to	Adjust the following Max. Peak Output
1	Tuning condenser stator (ant.) in series with .01 mfd	455 Kc	Bcst	Quiet point on high frequency end of dial	1st and 2nd IF transformers
2	Antenna term. of Ant. loop in series with 100 mfd.	1660 Kc	Bcst	Full clockwise (out of mesh)	B.C. Osc. Trimmer
3	Same	1500 Kc	Best	Signal (1500 Kc)	B.C. loop trimmer
4	Same	600 Kc	Best	600 Kc	Osc. padder (rock in)
5	Same	1660 Kc	Bcst	Full clockwise (out of mesh)	B.C. Osc. Trimmer
6	Ant. term. in series with 100 mfd and 400 ohm resistor	18.6 Mc	S.W.	Full clockwise (out of mesh)	S.W. Osc. Trimmer
7	Same	18.0 Mc	S.W.	Signal (18.0 Mc)	S.W. Ant. Trimmer

Espey Mfg. Co.
Models
20626-A,
and 97-A.

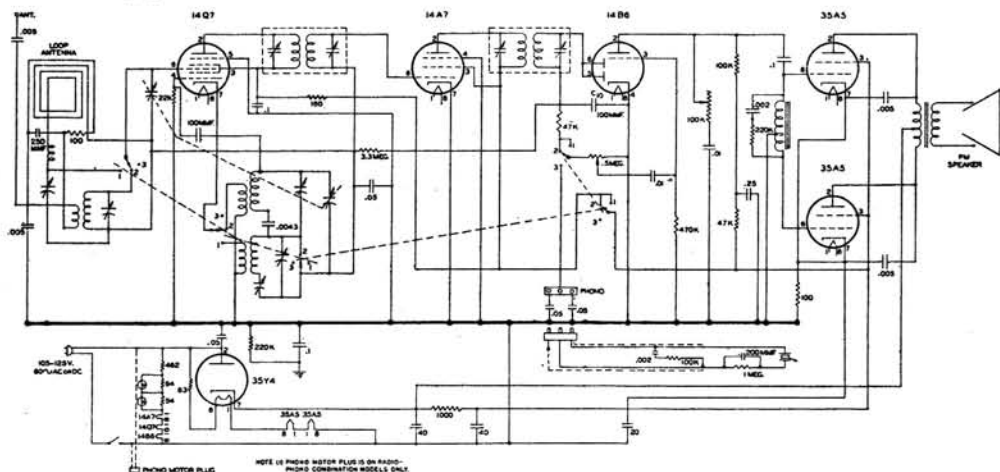

MANUAL OF 1948 MOST-OFTEN-NEEDED RADIO DIAGRAMS

Espey Mfg. Co.

MODEL 10536 A

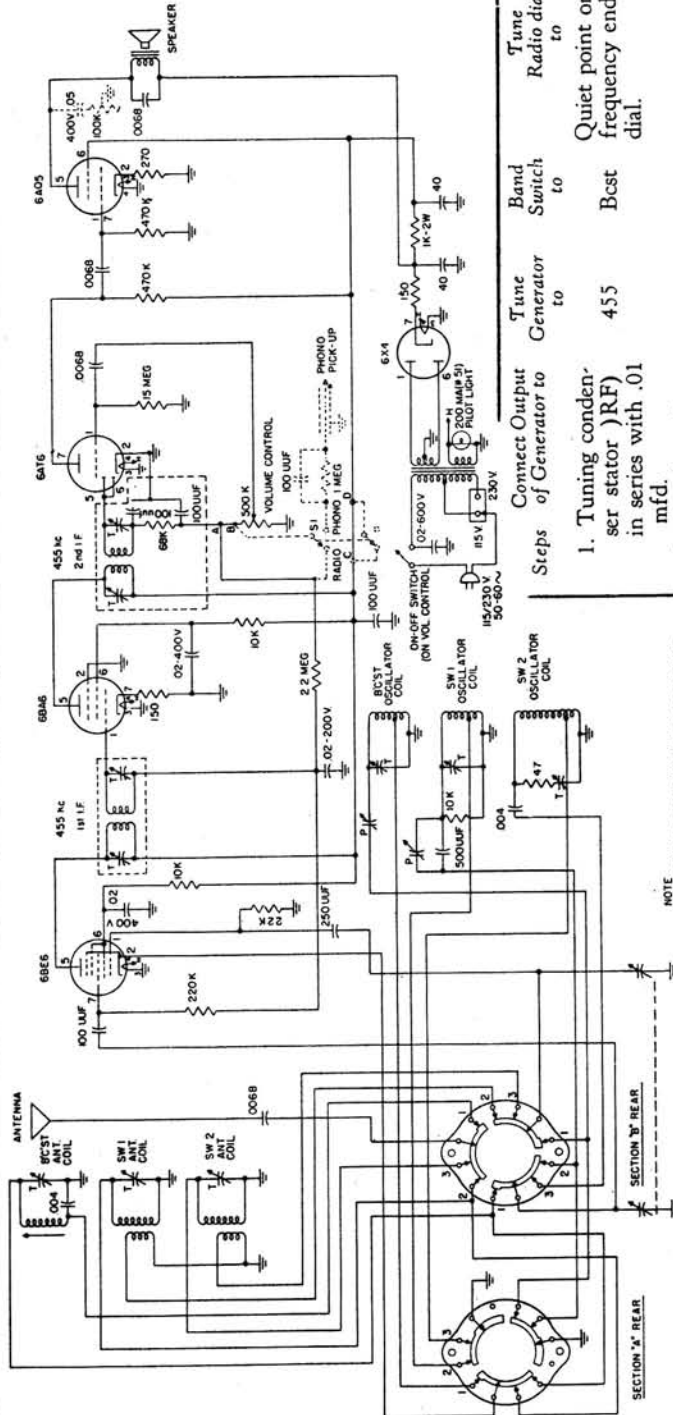

NOTE
 (1) POINTS A-B-C-D JUMPED IN RADIO MODELS.
 SWITCH S1 USED IN RADIO-PHONO COMBIN-
 (2) DOTTED LINES IN CIRCUIT USED IN PHONO
 COMBINATION ONLY.

POB 1-BCST
 POS 2-SW1
 POS 3-SW 2

SWITCH VIEWED FROM SHAFT
 END SHOWN IN BROADCAST POSITION

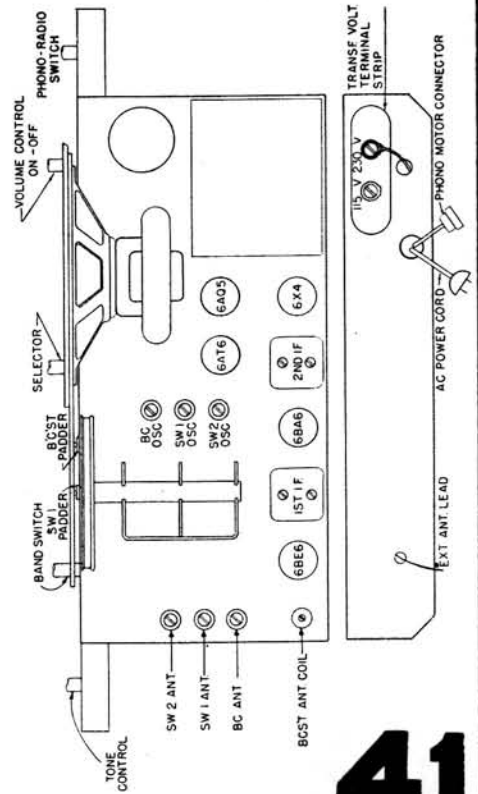

Adjust the following for maximum peak output

Steps of Generator to	Tune Generator to	Band Switch to	Tune Radio dial to
1. Tuning condenser (RF) in series with .01 mfd.	455	Best	Quiet point on high 1st and 2nd IF frequency end of transformers dial.
2. Ant in series with 200 mmf.	1500 kc	Best	*1500 kc on dial. BC Osc. trimmer
3. Same as above	1500	Best	Sig. (1500 kc). BC Ant. trimmer
4. Same as above	600 kc	Best	600 kc on dial. BC Osc. paddle Ant. coil core
5. Same as above	1500	Best	1500 on dial BC Ant. trimmer BC Osc. trimmer
6. Ant. in series with 400 ohm	6 Mc	SW1	6 Mc on dial SW1 Osc. trimmer
7. Same as above	6 Mc	SW1	6 Mc SW1 Ant. trimmer
8. Same as above	2.5 Mc	SW1	2.5 Mc Rock in SW1 Osc. paddle SW1 Ant. trimmer SW1 Osc. trimmer
9. Same as above	6 Mc	SW1	6 Mc SW2 Ant. trimmer
10. Same as above	21 Mc	SW2	21 Mc SW2 Osc. trimmer
11. Same as above	21 Mc	SW2	21 Mc SW2 Ant. trimmer

* Before aligning R.F. and Osc. set dial pointer on dial point marker with condenser fully meshed.

MANUAL OF 1948 MOST-OFTEN-NEEDED RADIO DIAGRAMS

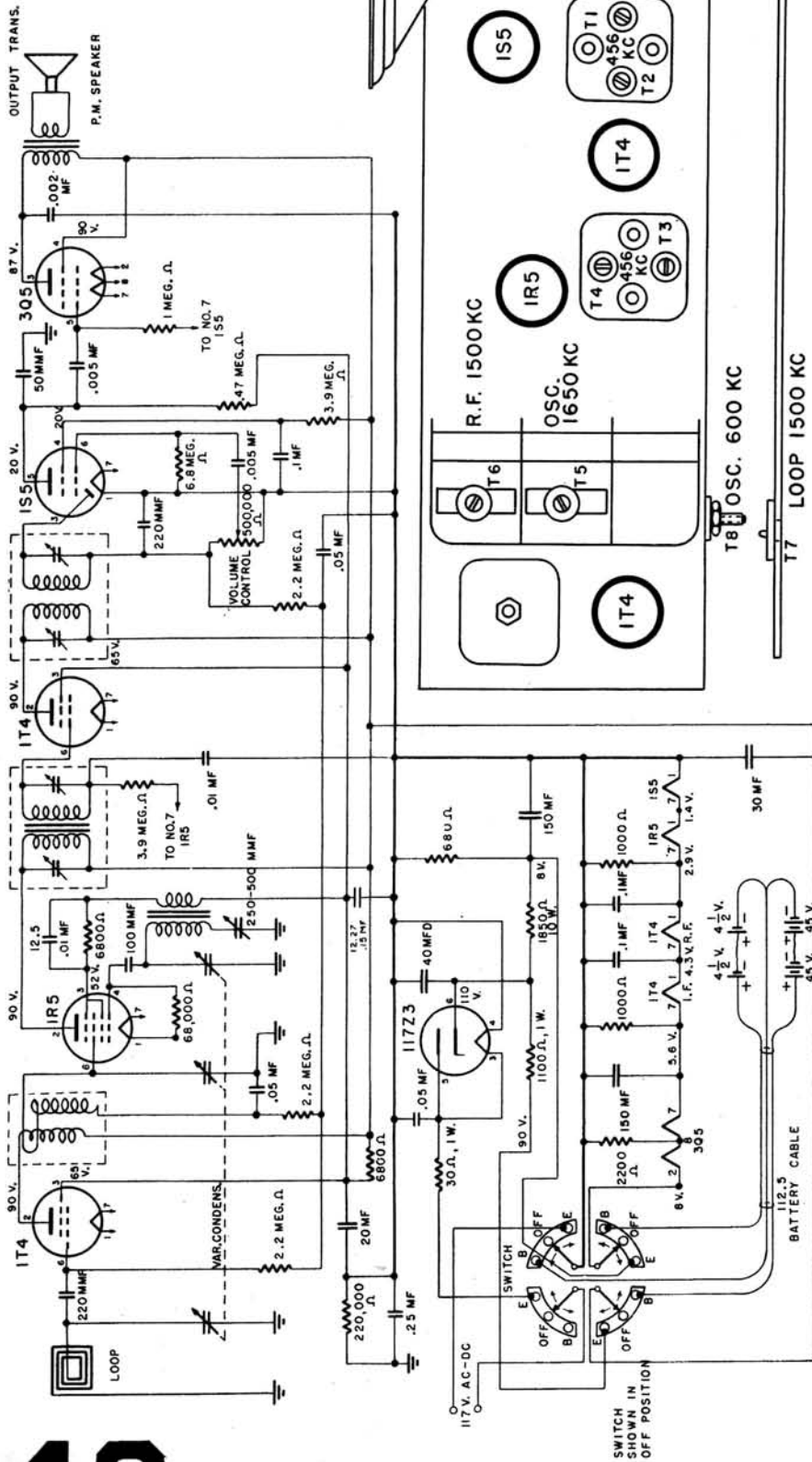

TUNING RANGE 538 - 1650 KC

NOTE:
K=1000 OHMS. MEG.=1,000,000 OHMS

GROUND

CONNECTED WIRES

ALL VOLTAGES MEASURED TO COMMON
UNLESS OTHERWISE SPECIFIED
20,000 OHMS PER VOLT METER
117 VOLT 60 CYCLE LINE
TUNING RANGE 538-1650 KC

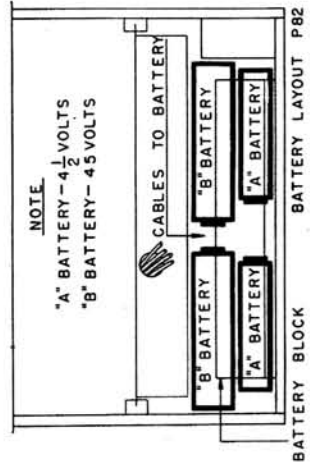

NOTE:

"A" BATTERY - 4 1/2 VOLTS
"B" BATTERY - 45 VOLTS

CABLES TO BATTERY
"B" BATTERY
"A" BATTERY
"B" BATTERY
"A" BATTERY
BATTERY BLOCK
BATTERY LAYOUT P82

Fada Radio & Electric

Models P-82, and P-100

MANUAL OF 1948 MOST-OFTEN-NEEDED RADIO DIAGRAMS

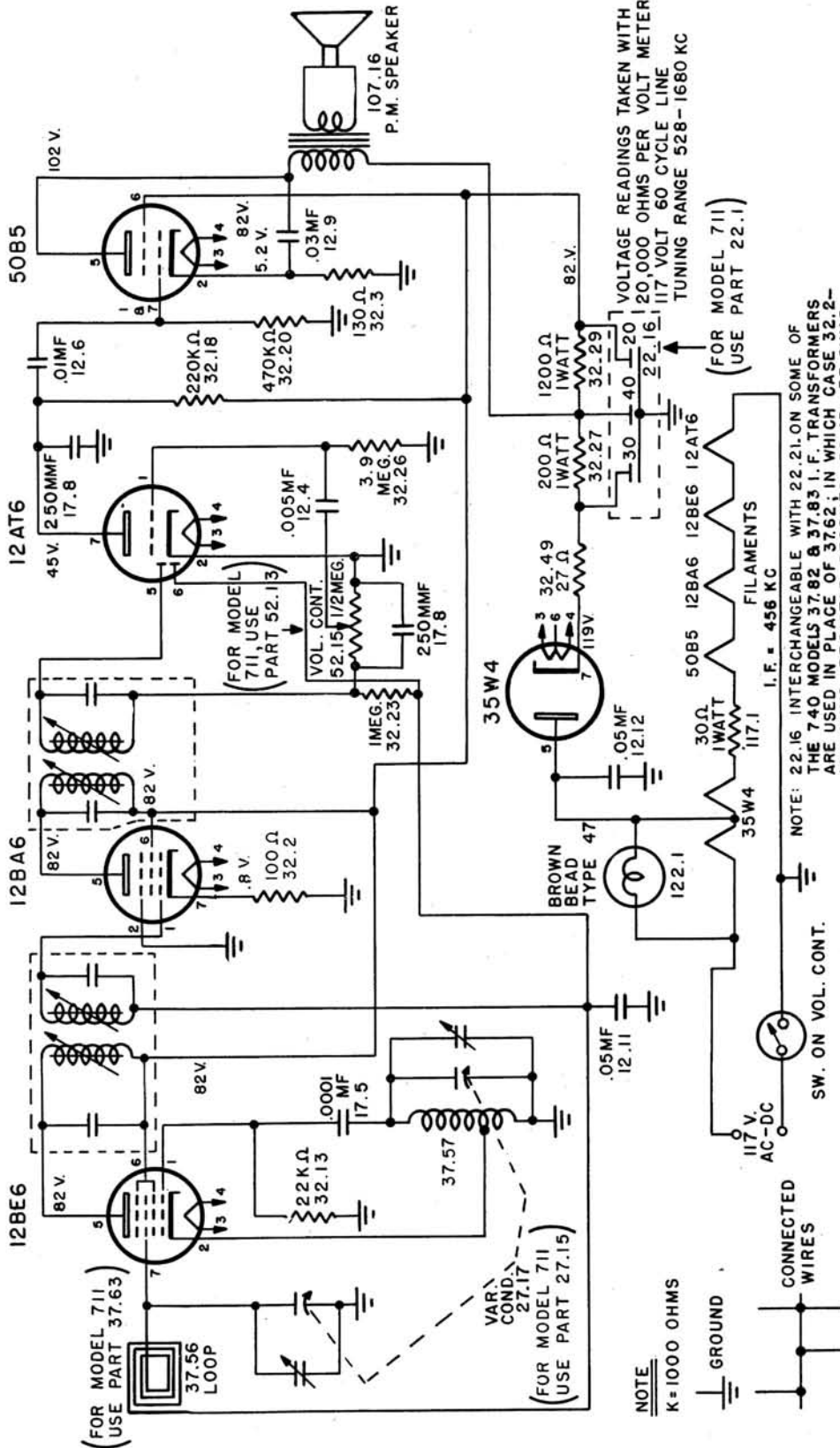

- Power consumption: 30 Watts
 Frequency Range: 530-1680 KC
 I.F. Circuits: 456 KC
- 12.4 Tubular Condenser, .005 mf, 600 V
 - 12.6 Tubular Condenser, .01 mf, 400 V
 - 12.9 Tubular Condenser, .03 mf, 400 V
 - 12.11 Tubular Condenser, .05 mf, 200 V
 - 12.12 Tubular Condenser, .05 mf, 400 V
 - 17.5 Mica Condenser, 100 mmf, ±10%
 - 17.8 Mica Condenser, 250 mmf, ±20%
 - 22.16 3 Section Electrolytic Condenser, 30-40-20 mf, 150 W.V.

MODEL 711 & 740
SCHEMATIC
 FADA RADIO & ELECTRIC CO. INC.
 BELLEVILLE, NEW JERSEY U.S.A.

MANUAL OF 1948 MOST-OFTEN-NEEDED RADIO DIAGRAMS

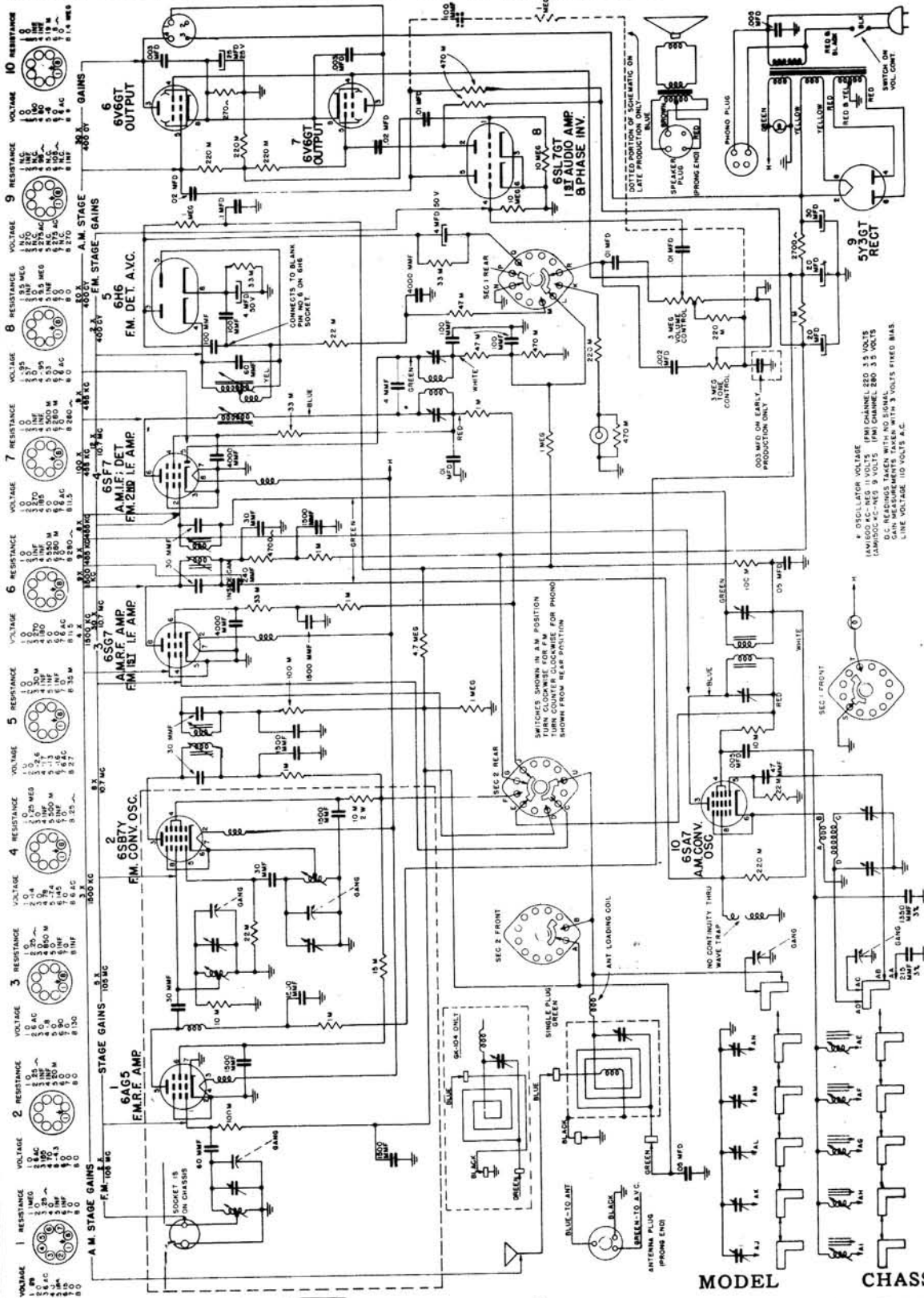

RESISTANCE	VOLTAGE	RESISTANCE	VOLTAGE	RESISTANCE	VOLTAGE	RESISTANCE	VOLTAGE	RESISTANCE	VOLTAGE
100K	100V	100K	100V	100K	100V	100K	100V	100K	100V
100K	100V	100K	100V	100K	100V	100K	100V	100K	100V
100K	100V	100K	100V	100K	100V	100K	100V	100K	100V
100K	100V	100K	100V	100K	100V	100K	100V	100K	100V

OSCILLATOR VOLTAGE (FM CHANNEL) 220 3.5 VOLTS
 (AM) 500 KC-1 MC 9 VOLTS (FM CHANNEL) 280 3.5 VOLTS
 D.C. READING TAKEN WITH NO SIGNAL
 (A.C. READING TAKEN WITH 3 VOLTS FIXED BIAS)
 LINE VOLTAGE 110 VOLTS A.C.

AM Intermediate Frequency 455 KC.
 FM Intermediate Frequency 10.7 MC.

MODEL	CHASSIS
GK-100	C-170
GK-102	C-194
GK-103	C-216
GK-104	C-201

MANUAL OF 1948 MOST-OFTEN-NEEDED RADIO DIAGRAMS

FARNSWORTH TELEVISION & RADIO CORPORATION

MODEL EF-451
CHASSIS -C-196

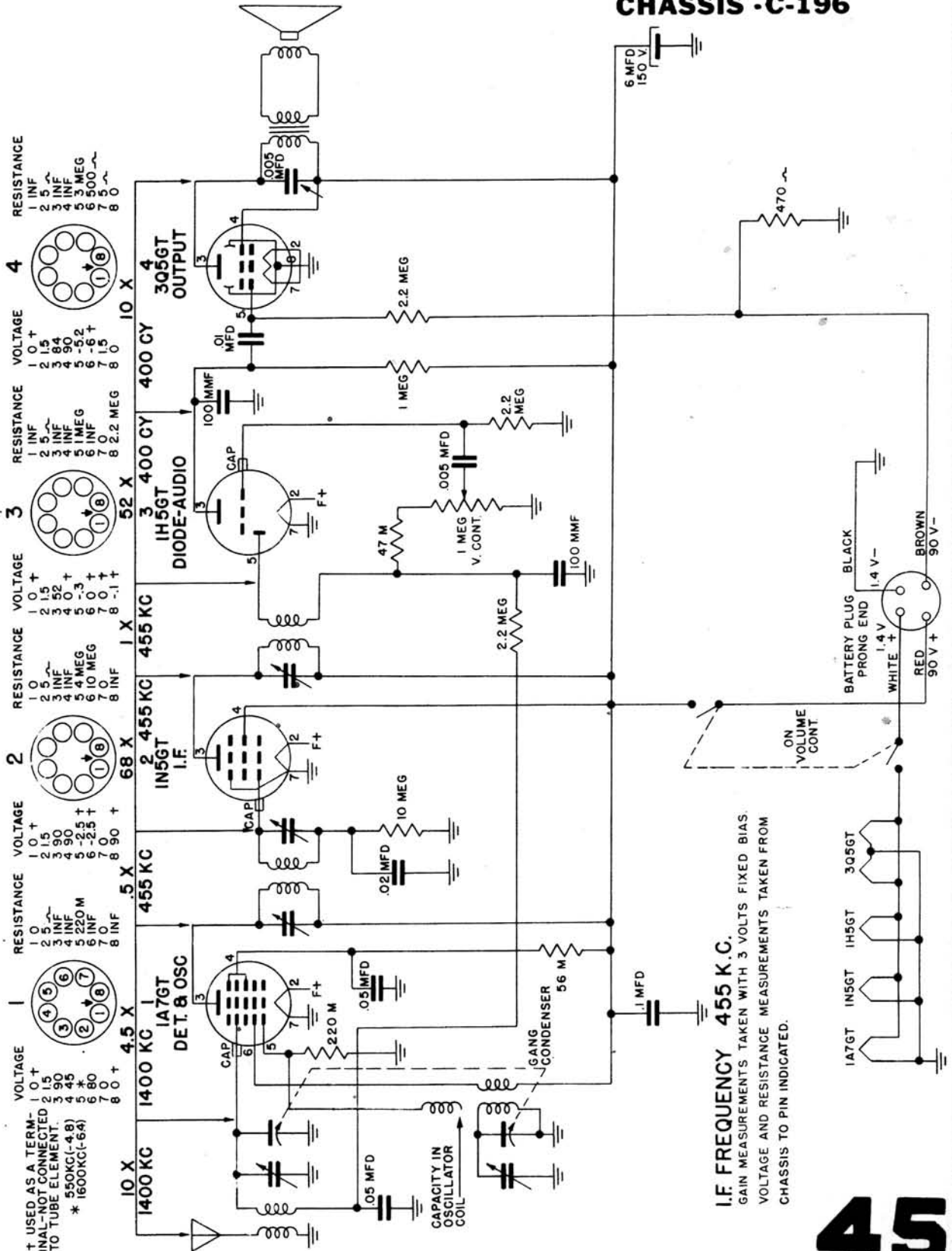

MANUAL OF 1948 MOST-OFTEN-NEEDED RADIO DIAGRAMS

Gamble-Skogmo, Inc.
Coronado Model 43-5005

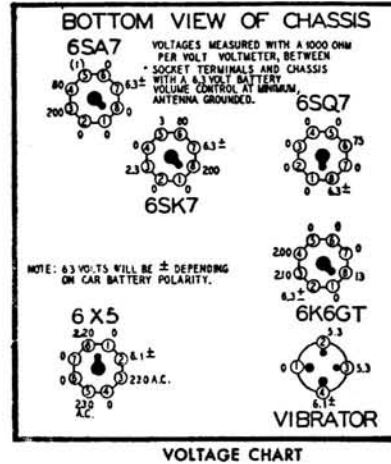
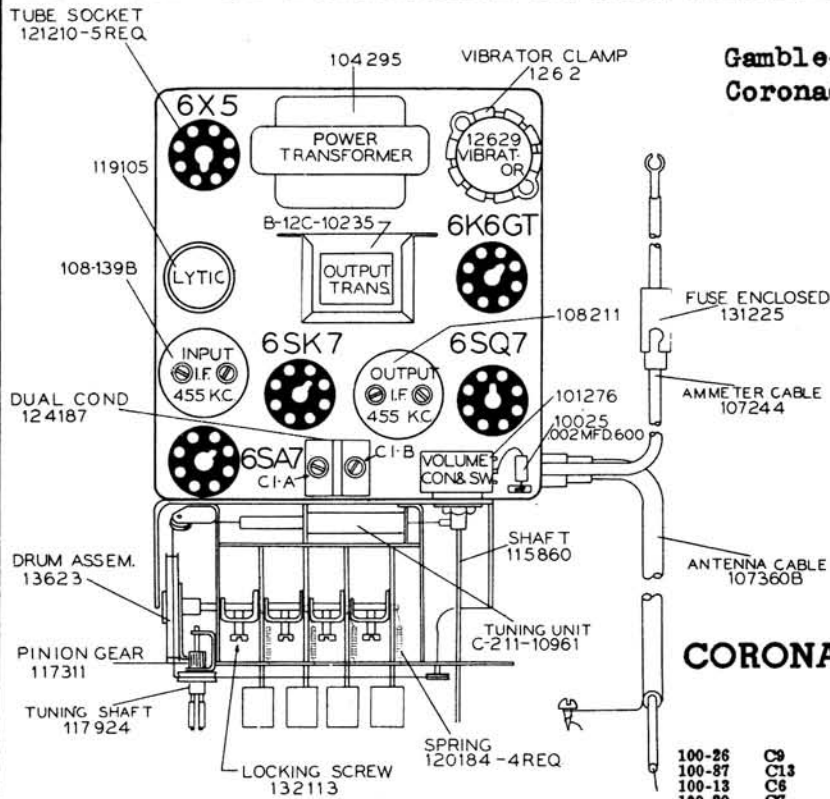

CORONADO MODEL 43-5005

RESISTORS

C-9B1-35	R9	4.7 Megohm, 1/4 Watt—20%	1
C-9B1-27	R10	220K Ohm, 1/4 Watt—20%	1
C-9B1-29	R11	470K Ohm, 1/4 Watt—20%	1
C-9B1-60	R12	680 Ohm, 1/2 Watt—10%	1
C-9B1-34	R6	3.3 Megohm, 1/4 Watt—20%	1
C-9B1-23	R7	47K Ohm, 1/2 Watt—20%	1
C-9B1-31	R1	1 Megohm, 1/4 Watt—20%	1
C-9B1-22	R2	33K Ohm, 1/2 Watt—20%	1
C-9B2-76	R3	15K Ohm, 1 Watt—10%	1
C-9B2-64	R15	1500 Ohm, 1 Watt—10%	1
C-9B1-60	R13, R14	100 Ohm, 1/4 Watt—10%	2
C-9B1-62	R4	150 Ohm, 1/4 Watt—10%	1
C-9B1-66	R5	330 Ohm, 1/2 Watt—10%	1

CONDENSERS

100-26	C9	.02 x 400 Volt Tubular	1
100-87	C13	.01 x 600 Volt Tubular	1
100-13	C6	.05 x 400 Volt Tubular	1
100-20	C7	.1 x 200 Volt Tubular	1
100-9	C5	.05 x 200 Volt Tubular	1
100-125	C14	.0035 x 1600 Volt Tubular	1
100-25	C11	.002 x 600 Volt Tubular	1
100-31	C15, C16, C17	.5 x 120 Volt Oval Type	3
100-81		.5 Mfd. Generator Cond.	1
100-82		.5 Mfd. Ammeter Cond.	1
119-105	C12 A-B-C	Electrolytic Filter Condenser—20 Mfd. x 25 Volt; 15 Mfd. x 350 Volt; 15 Mfd. x 350 Volt	1
124-187	C1-A-B	Ant. and Osc. Dual Trimmer	1
129-161	C8A-B	.0001 Dual Mica—10%	1
129-2	C3, C10	.0005 Mica Type—20%	2
129-188	C2	.00008 Mica Type—3%	1
129-21	C4	.0002 Mica Type—20%	1
129-12	C19	.00025 Mica Type—20%	1
11749B	C18	Spark Plate	1

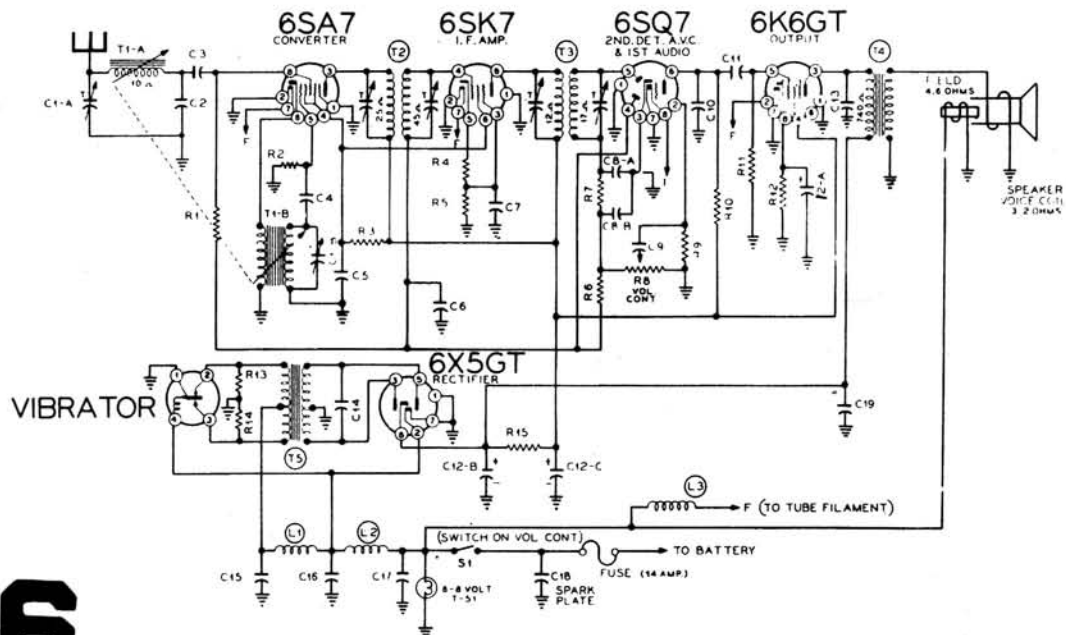

46

ON SOME SETS R-5 AND C-7 IS ELIMINATED AND THE CATHODE OF THE 6SK7 IS GROUND

MANUAL OF 1948 MOST-OFTEN-NEEDED RADIO DIAGRAMS

SCHMATIC DIAGRAM FOR MODELS 43-8177, 43-8178

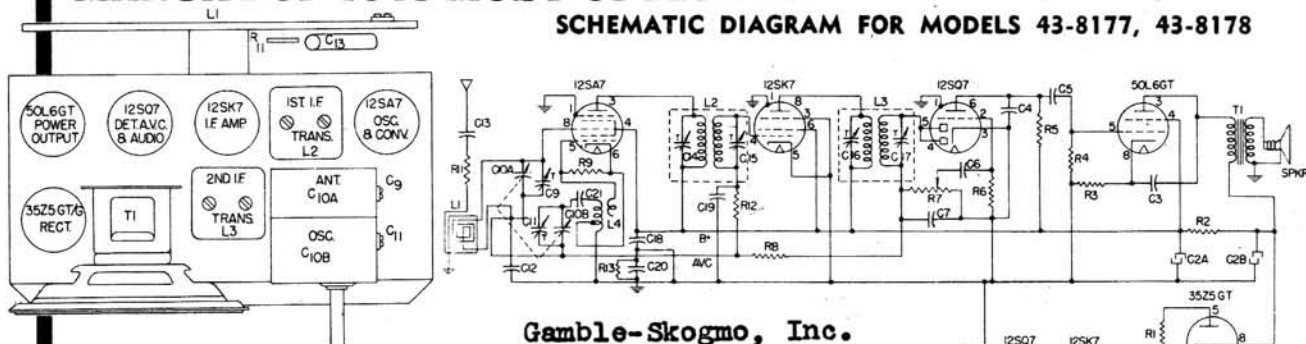

Gamble-Skogmo, Inc.

CORONADO RADIO MODELS 43-8177, 43-8178, 43-8179

SCHMATIC DIAGRAM FOR MODEL 43-8179

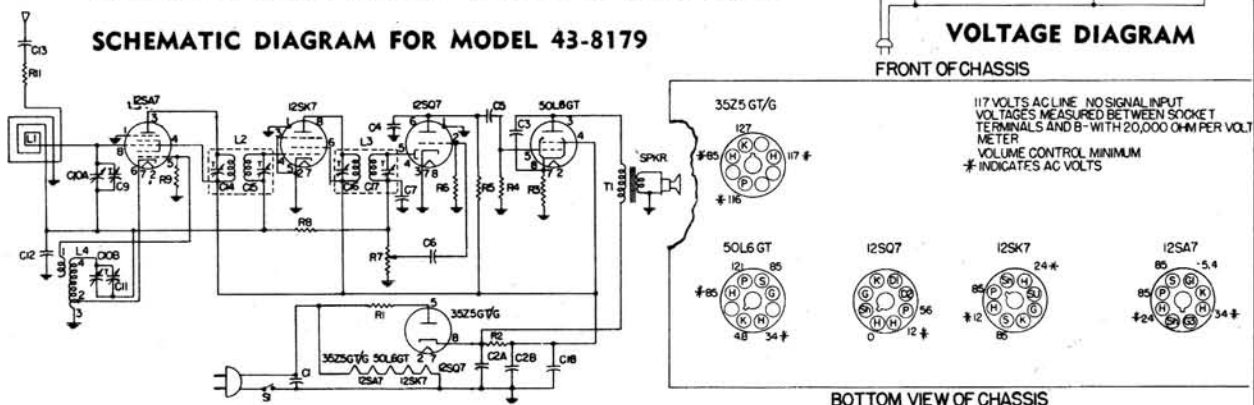

PARTS DESCRIPTION LIST

MODELS 43-8177, 43-8178, 43-8179

CATALOG NO.	SYMBOL	TITLE	VALUE	RATING	TOLERANCE
UCC-045	C1	Paper Capacitor	.05 mf	600WVDC	+40 - 15%
SCE-003	C2A	Electrolytic Capacitor	40 mf	150WVDC	+100 - 10%
SCE-003	C2B	Electrolytic Capacitor	40 mf	150WVDC	+100 - 10%
UCC-041	C3	Paper Capacitor	.02 mf	600WVDC	±20%
UCU-1040	C4	Mica Capacitor	330 mmf	500WVDC	±10%
UCC-040	C5	Paper Capacitor	.01 mf	400WVDC	±20%
UCC-039	C6	Paper Capacitor	.006 mf	600WVDC	+40 - 15%
UCU-1040	C7	Mica Capacitor	330 mmf	500WVDC	±10%
*	C9	Antenna Trimmer			
*	C10A	Variable Condenser ant. section			
*	C10B	Variable Condenser osc. section			
*	C11	Oscillator Trimmer			
UCC-045	C12	Paper Capacitor	.05 mf	400WVDC	±20%
UCC-039	C13	Paper Capacitor	.005 mf	600WVDC	±20%
UCC-045	C18	Paper Capacitor	.05 mf	400WVDC	±20%
URE-007	R1	Carbon Resistor	22 ohm	½ W	±20%
URF-053	R2	Carbon Resistor	1500 ohm	2 W	±20%
URD-029	R3	Carbon Resistor	150 ohm	½ W	±20%
URD-113	R4	Carbon Resistor	470,000 ohm	½ W	±20%
URD-105	R5	Carbon Resistor	220,000 ohm	½ W	±20%
URD-145	R6	Carbon Resistor	10 megohm	½ W	±20%
SRC-004	R7	Volume Control	500,000 ohm		
URD-129	R8	Carbon Resistor	2.2 megohm	½ W	±20%
URD-081	R9	Carbon Resistor	22,000 ohm	½ W	±20%
URD-041	R11	Carbon Resistor	470 ohm	½ W	±20%
*	L1	Antenna Loop			
*	L2	1st IF Transformer			
*	L3	2nd IF Transformer	455 K.C.		
SLC-001	L4	Oscillator Coil			
*	T1	Output Transformer			
SRC-004	S1	Power Switch with R7			
*	SPKR	4" PM Speaker			
SJS-002		Socket-Octal base tube			
SMS-003		Speed Nuts—for fastening metal grille in cabinet			

ADDITIONAL PARTS FOR MODEL 43-8179

UCC-039	C19	Paper Capacitor	.005 mf	600WVDC
UCC-048	C20	Paper Capacitor	.1 mf	400WVDC
UCC-040	C21	Paper Capacitor	.01 mf	400WVDC
URD-113	R12	Carbon Resistor	470,000 ohm	½ W
URD-113	R13	Carbon Resistor	470,000 ohm	½ W

MANUAL OF 1948 MOST-OFTEN-NEEDED RADIO DIAGRAMS

Gamble-Skogmo, Inc.

CORONADO RADIO MODEL 43-8190

ALIGNMENT PROCEDURE

Allow unit to heat for a few minutes before starting alignment.

Volume control set to maximum.

Output meter across speaker.

Align for maximum output.

Keep input as low as readable meter reading of output will permit.

Note: If signal generator is AC operated, use an isolating transformer between the power supply and the radio receiver power input. The use of an isolating capacitor is not recommended as AC through the capacitor will introduce hum and/or create the possibility of a burned out signal generator attenuator.

FREQUENCY	SIGNAL COUPLING CAPACITOR	GENERATOR CONNECTION TO RADIO	GROUND CONNECTION	TUNING CONDENSER SETTING	ADJUST TRIMMERS FOR MAXIMUM OUTPUT (in order shown)
455 KC	0.1 mf	Converter grid	B-	Wide open	2nd IF transformer trimmer 1st IF transformer trimmer
1720 KC	200 mmf	Receiver antenna post	Chassis	Wide open	Oscillator trimmer C3
1500 KC	200 mmf	Receiver antenna post	Chassis	Tune for maximum output	Antenna trimmer C1

SYMBOL	TITLE	VALUE	RATING	TOLERANCE	PART NO
C1	Antenna trimmer				*
C2A	Variable Condenser ant. section				SCT-013
C2B	Variable Condenser osc. section				SCT-013
C3	Oscillator trimmer				*
C8	Mica capacitor	220 mmf	500WVDC	±20%	UCU-036
C9	Paper capacitor	.005mf	600WVDC	+40-15%	UCC-044
C10	Mica capacitor	220 mmf	500WVDC	±20%	UCU-036
C11	Paper capacitor	.01mf	600WVDC	±20%	UCC-040
C12	Paper capacitor	.02mf	600WVDC	±20%	UCC-041
C13A	Electrolytic capacitor	30mf	150WVDC		SCE-026
C13B	Electrolytic capacitor	30mf	150WVDC		SCE-026
C14	Paper capacitor	.05mf	600WVDC	±20%	UCC-045
C15	Paper capacitor	.05mf	600WVDC	±20%	UCC-045
C16	Paper capacitor	.05mf	600WVDC	±20%	UCC-045
C17	Paper capacitor	.01 mf	600WVDC	±20%	UCC-040
C19	Paper capacitor	.1mf	600WVDC	+20-10%	UCC-048
C20	Paper capacitor	.02mf	600WVDC	±20%	UCC-041
C21	Paper capacitor	.005mf	600WVDC	+40-15%	UCC-044
R1	Carbon resistor	22,000 ohm	½ W	±20%	URD-081
R2	Carbon resistor	2.2 megohm	½ W	±20%	URD-129
R3	Volume control	0.5 megohm			SRC-070
R4	Carbon resistor	4.7 megohm	½ W	±20%	URD-137
R5	Carbon resistor	470,000 ohm	½ W	±20%	URD-113
R6	Carbon resistor	470,000 ohm	½ W	±20%	URD-113
R7	Carbon resistor	150 ohm	½ W	±20%	URD-029
R8	Carbon resistor	2700 ohm	2 W	±20%	URE-059
R9	Carbon resistor	18 ohm	½ W	±10%	URD-007
R10	Carbon resistor	470,000 ohm	½ W	±10%	URD-113
R11	Carbon resistor	470 ohm	½ W	±20%	URD-041
R12	Carbon resistor	470,000 ohm	½ W	±20%	URD-113

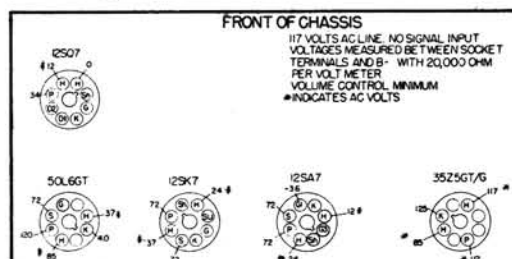
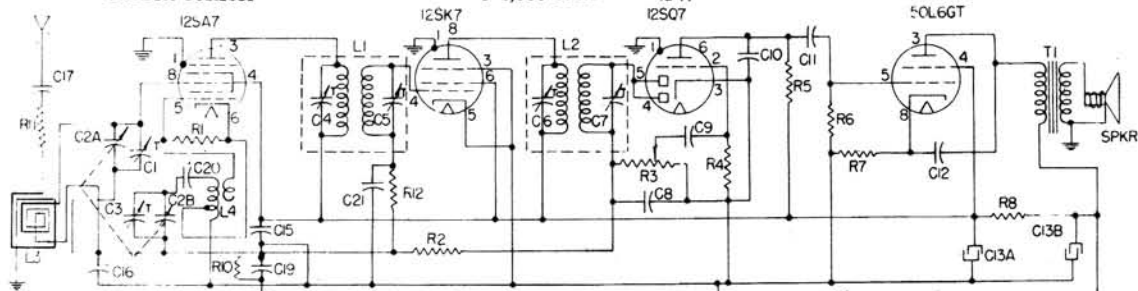

MANUAL OF 1948 MOST-OFTEN-NEEDED RADIO DIAGRAMS

Gamble-Skogmo, Inc.

CORONADO RADIO MODEL 43-8201

FREQUENCY	SIGNAL COUPLING CAPACITOR	GENERATOR CONNECTION TO RADIO	GROUND CONNECTION	TUNING CONDENSER SETTING	ADJUST TRIMMERS FOR MAXIMUM OUTPUT (in order shown)
455 KC	0.1 mf	Converter grid	Chassis	Wide open	2nd IF transformer trimmer 1st IF transformer trimmer
1720 KC	200 mmf	Receiver antenna post	Chassis	Wide open	Oscillator trimmer C11
1500 KC	200 mmf	Receiver antenna post	Chassis	Tune for maximum output	Antenna trimmer C9

PARTS DESCRIPTION LIST

SYMBOL	TITLE	VALUE	RATING	TOLERANCE	PART NO
C1	Paper capacitor	.05mf	600WDVC	+40-10%	UCC-045
C2A	Electrolytic capacitor	40mf	150WVDC	+100-10%	SCE-003
C2B	Electrolytic capacitor	40mf	150WVDC	+100-10%	SCE-003
C3	Paper capacitor	.02mf	600WDVC	+40-10%	UCC-041
C4	Mica capacitor	330mmf	500WVDC	±20%	UCU-1040
C5	Paper capacitor	.01mf	600WDVC	+40-10%	UCC-040
C6	Paper capacitor	.005mf	600WDVC	+40-10%	UCC-039
C7	Mica capacitor	330mmf	500WVDC	±20%	UCU-1040
C8	Mica capacitor	47mmf	500WVDC	±20%	UCU-1020
C12	Paper capacitor	.05mf	600WDVC	+40-10%	UCC-045
C18	Paper capacitor	.05mf	600WDVC	+40-10%	UCC-045
C19	Paper capacitor	.005mf	600WDVC	+40-10%	UCC-039
R1	Carbon resistor	18 ohm	1w	±20%	URE-007
R2	Carbon resistor	150 ohm	2w	±20%	URE-053
R3	Carbon resistor	150 ohm	½ w	±20%	URD-029
R4	Carbon resistor	470,000 ohm	½ w	±20%	URD-113
R5	Carbon resistor	220,000 ohm	½ w	±20%	URD-105
R6	Carbon resistor	10 megohm	½ w	±20%	URD-145
R7	Volume control	.5 megohm			SRC-004
R8	Carbon resistor	2.2 megohm	½ w	±20%	URD-129
R9	Carbon resistor	22,000 ohm	½ w	±20%	URD-081

SOCKET VOLTAGE LAYOUT

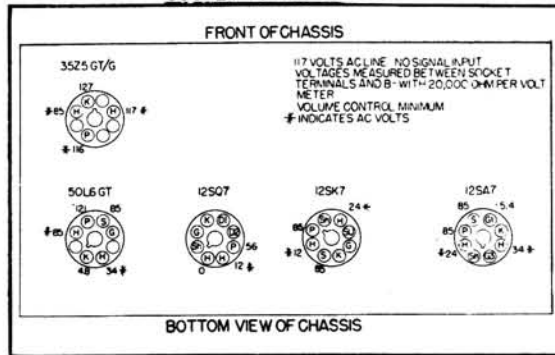

TUBE & TRIMMER LOCATION

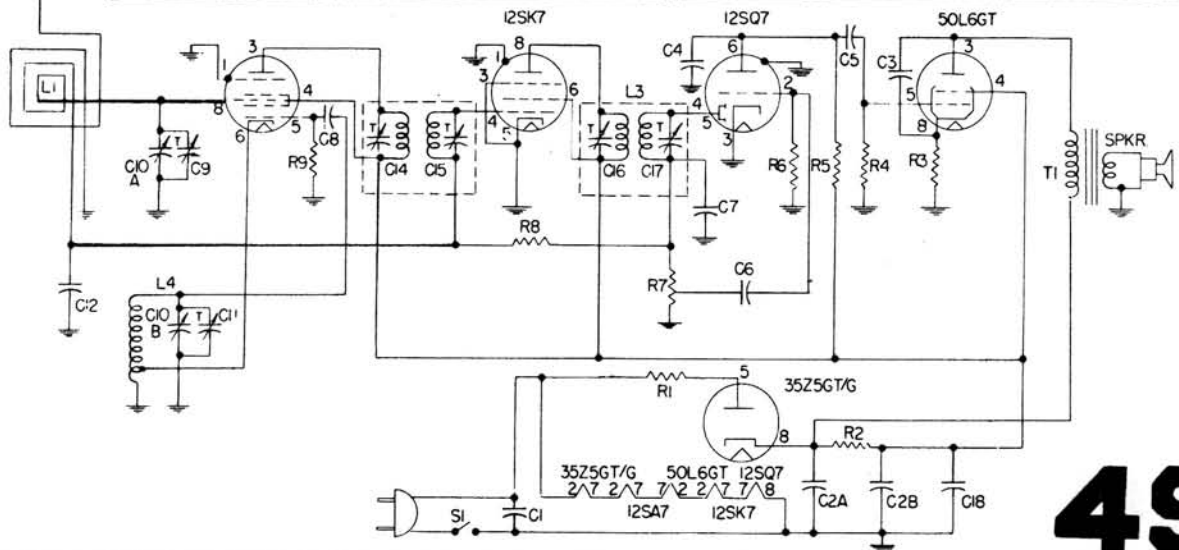
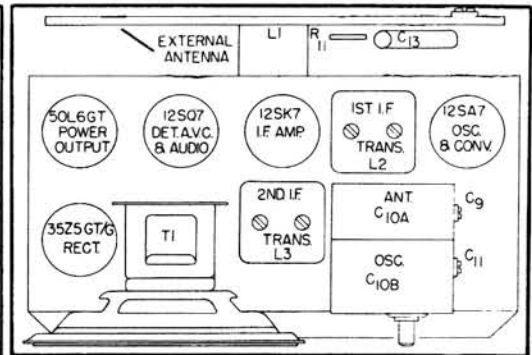

MANUAL OF 1948 MOST-OFTEN-NEEDED RADIO DIAGRAMS

Gamble-Skogmo, Inc. Coronado Models 43-8353 & 43-8354

ALIGNMENT PROCEDURE

(Refer to Chassis View)

- Output meter across 3.2-ohm output load.
- Volume control at maximum.
- Connect ground post of signal generator to B— of radio.
- Align for maximum output. Reduce input as needed to keep output near 0.4 volts.

SIGNAL GENERATOR

Frequency	Dummy Antenna	Connection to Radio
455 kc	0.1 mf	Stator of antenna section of gang
1650 kc	0.1 mf	Stator of antenna section of gang
1400 kc	200 mmf	External antenna clip

TUNER SETTING

Rotor full open
(plates out of mesh)

Rotor full open
(plates out of mesh)

1400 kc

ADJUST FOR MAXIMUM OUTPUT (in order shown)

Trimmers on output and input I.F. cans

Oscillator trimmer C-3B

Antenna trimmer C-3A

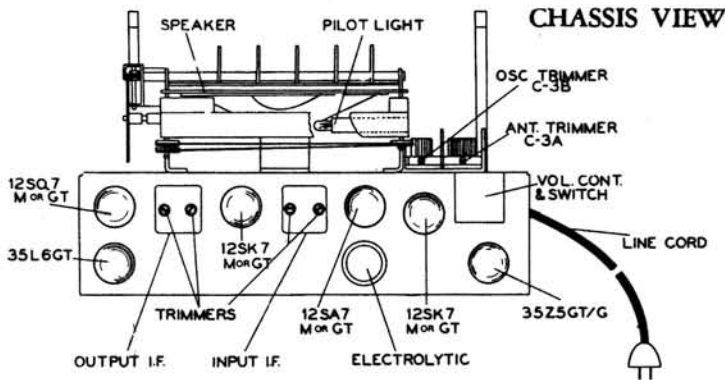

DRIVE CORD REPLACEMENT

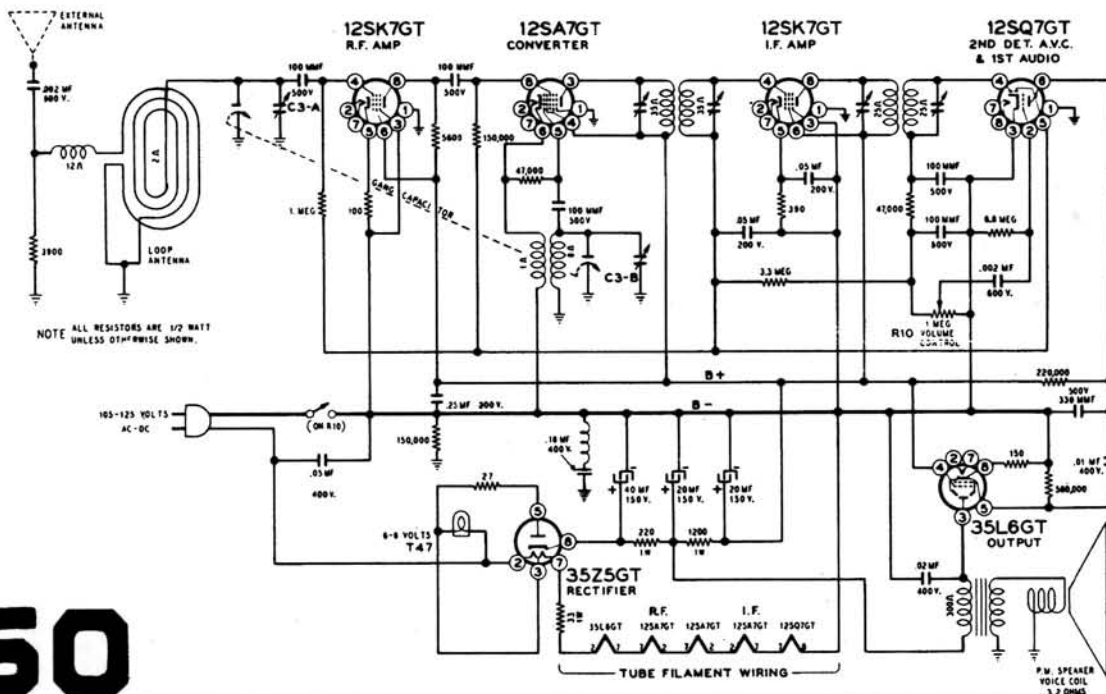
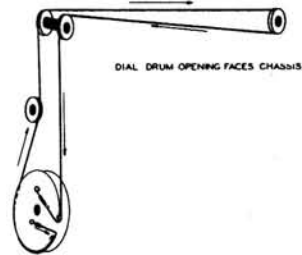

MANUAL OF 1948 MOST-OFTEN-NEEDED RADIO DIAGRAMS

GAROD RADIO

MODEL 5A1

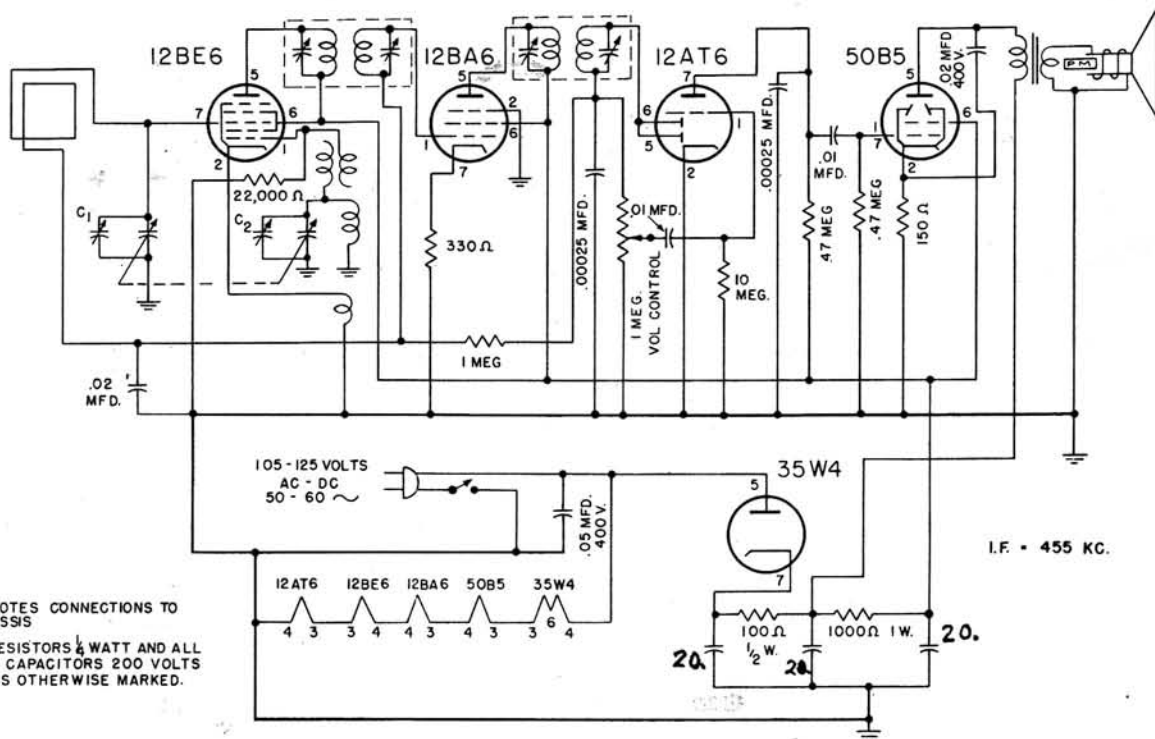

⊥ DENOTES CONNECTIONS TO CHASSIS

ALL RESISTORS $\frac{1}{8}$ WATT AND ALL PAPER CAPACITORS 200 VOLTS UNLESS OTHERWISE MARKED.

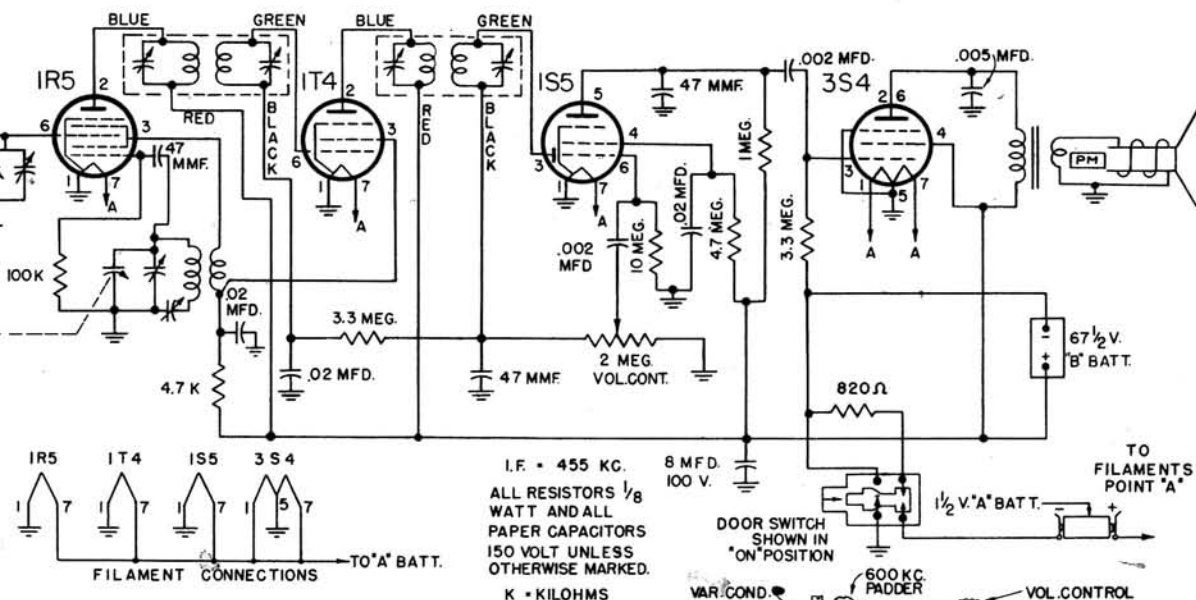

MODEL 4A-1 & 4A-2

4 TUBE SUPERHETERODYNE
PERSONAL BATTERY RECEIVER

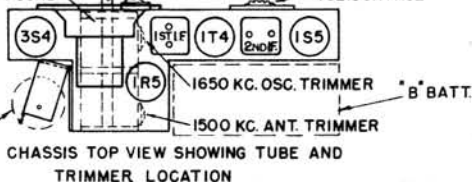

52

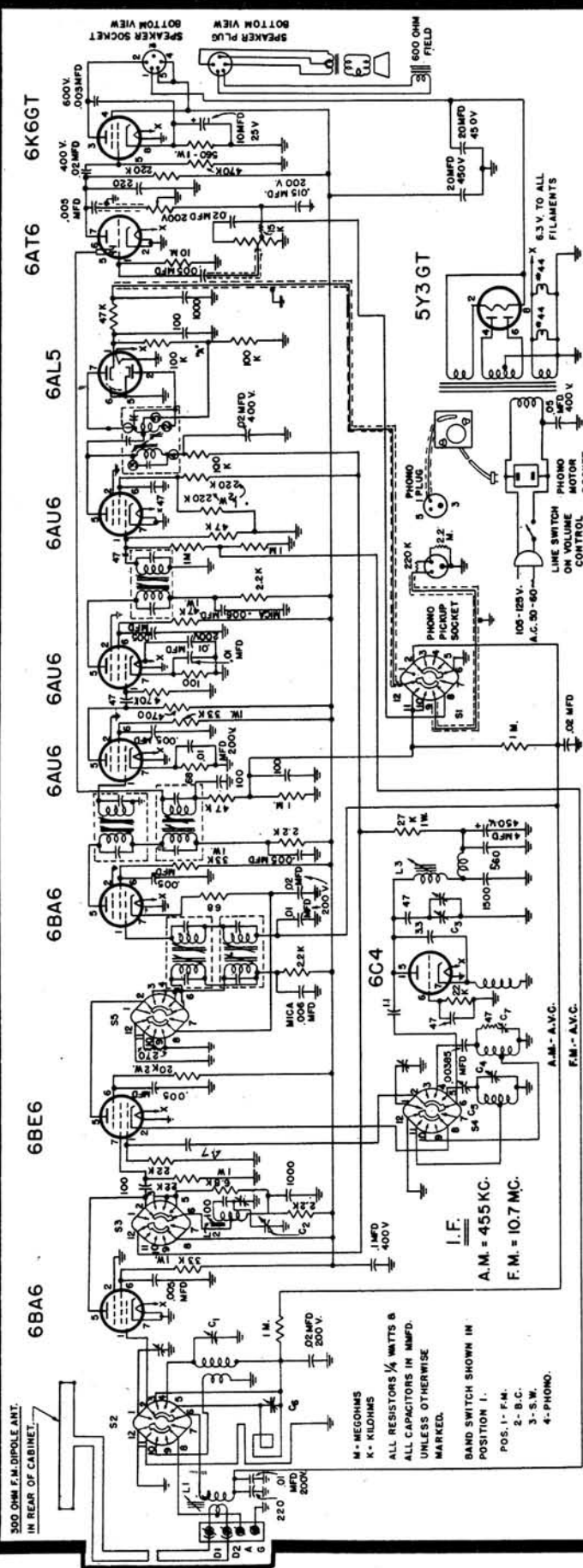

GARROD

MODEL 11 FMP

TUNING RANGE:
 Broadcast Band: 540 to 1650 Kilocycles
 (180 to 555 Meters)
 Short Wave Band: 5.3 to 18.5 Megacycles
 (16 to 56 Meters)
 F-M Band:
 87.5 to 108.5 Megacycles
 (2.7 to 3.4 Meters)

TRIMMERS

- C₁ S-W ANT.
- C₂ F-M R-F
- C₃ F-M OSC.
- C₄ B-C OSC.
- C₅ B-C PADDER
- C₆ B-C ANT.
- C₇ S-W OSC.

TRIMMER RANGES (MINF)

C ₁	2-18
C ₂	2-18
C ₃	1.0-3.5 (CERAMIC)
C ₄	3-35
C ₅	110-560
C ₆	2-12
C ₇	2-18

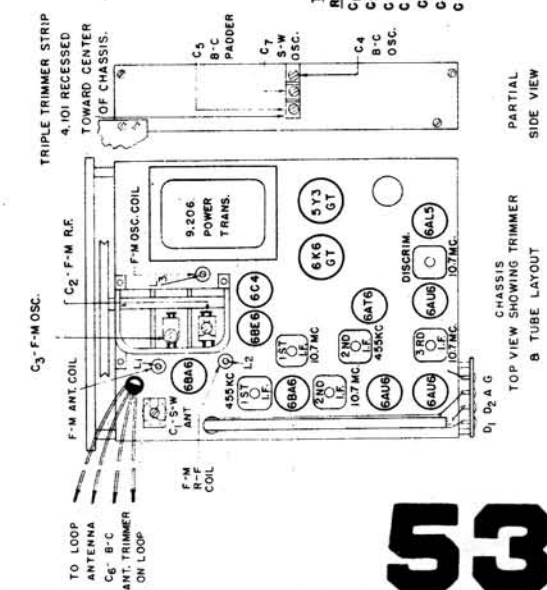

500 OHM F.M. DIPOLE ANT. IN REAR OF CABINET.

M - MEGOHMS
 K - KILOHMS
 ALL RESISTORS 1/2 WATTS & ALL CAPACITORS IN MFD. UNLESS OTHERWISE MARKED.

I.F. = 455 KC.
 A.M. = 10.7 MC.
 F.M. = 10.7 MC.

BAND SWITCH SHOWN IN POSITION 1.
 POS. 1 - F.M.
 2 - B.C.
 3 - S.W.
 4 - PHONO.

MANUAL OF 1948 MOST-OFTEN-NEEDED RADIO DIAGRAMS

GENERAL ELECTRIC COMPANY
MODELS 41, 42, 43, 44, 45

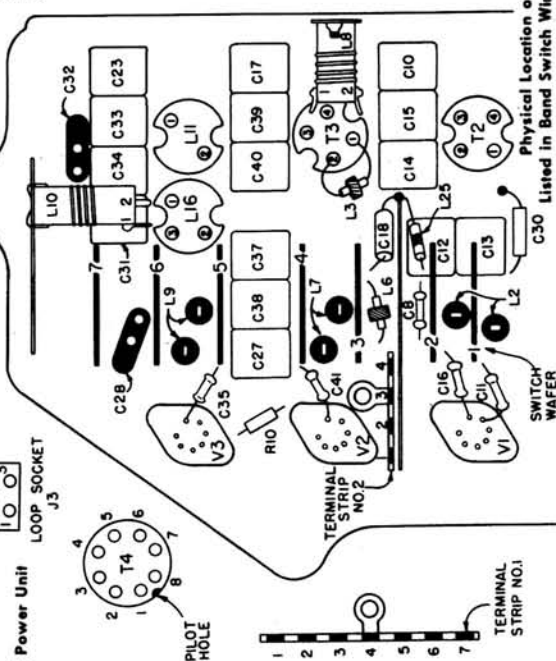
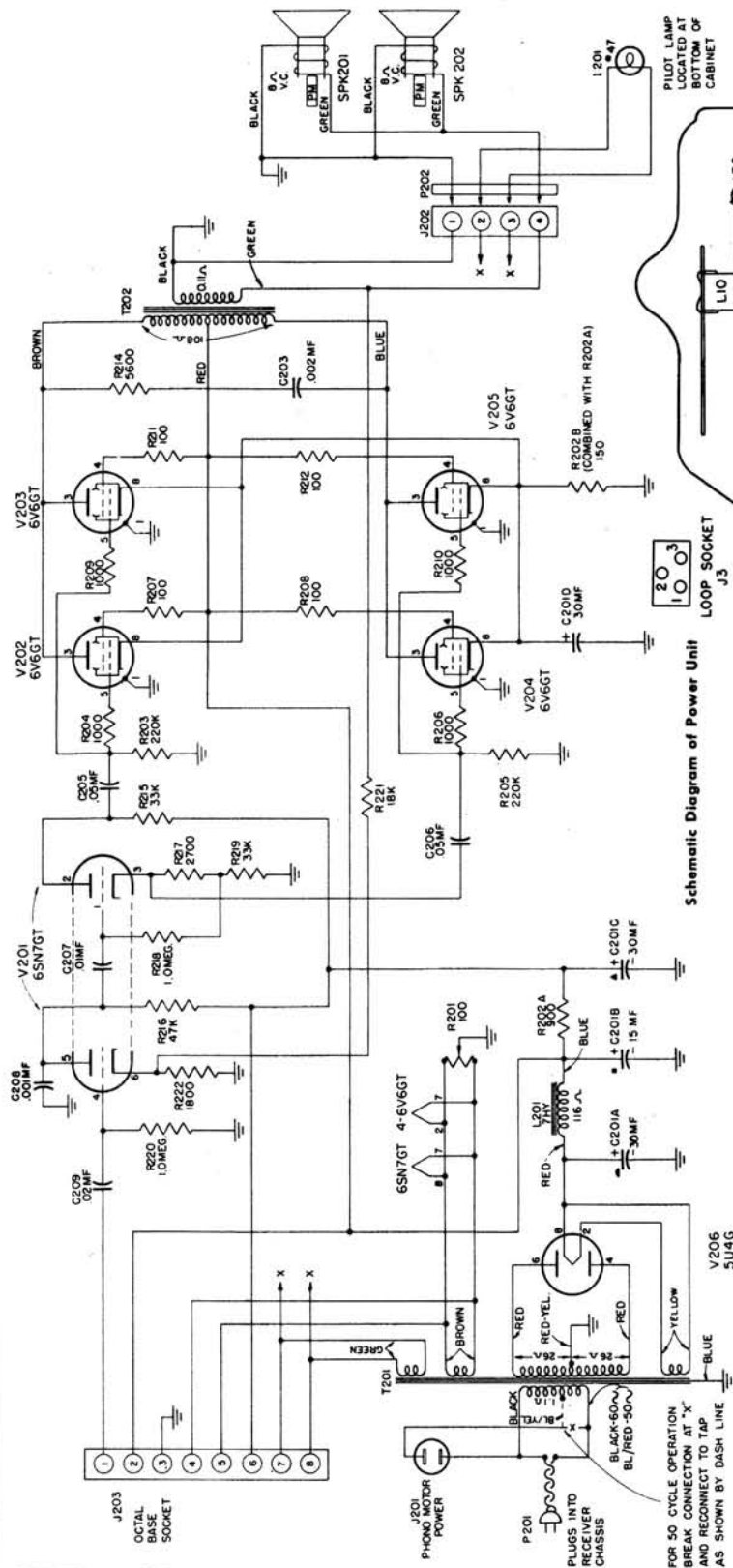

Schematic Diagram of Power Unit

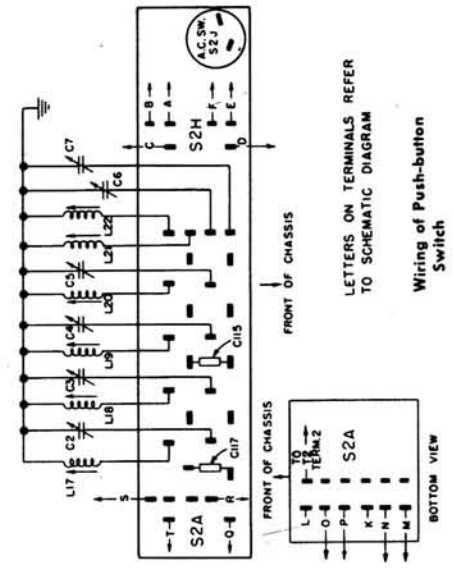

MANUAL OF 1948 MOST-OFTEN-NEEDED RADIO DIAGRAMS

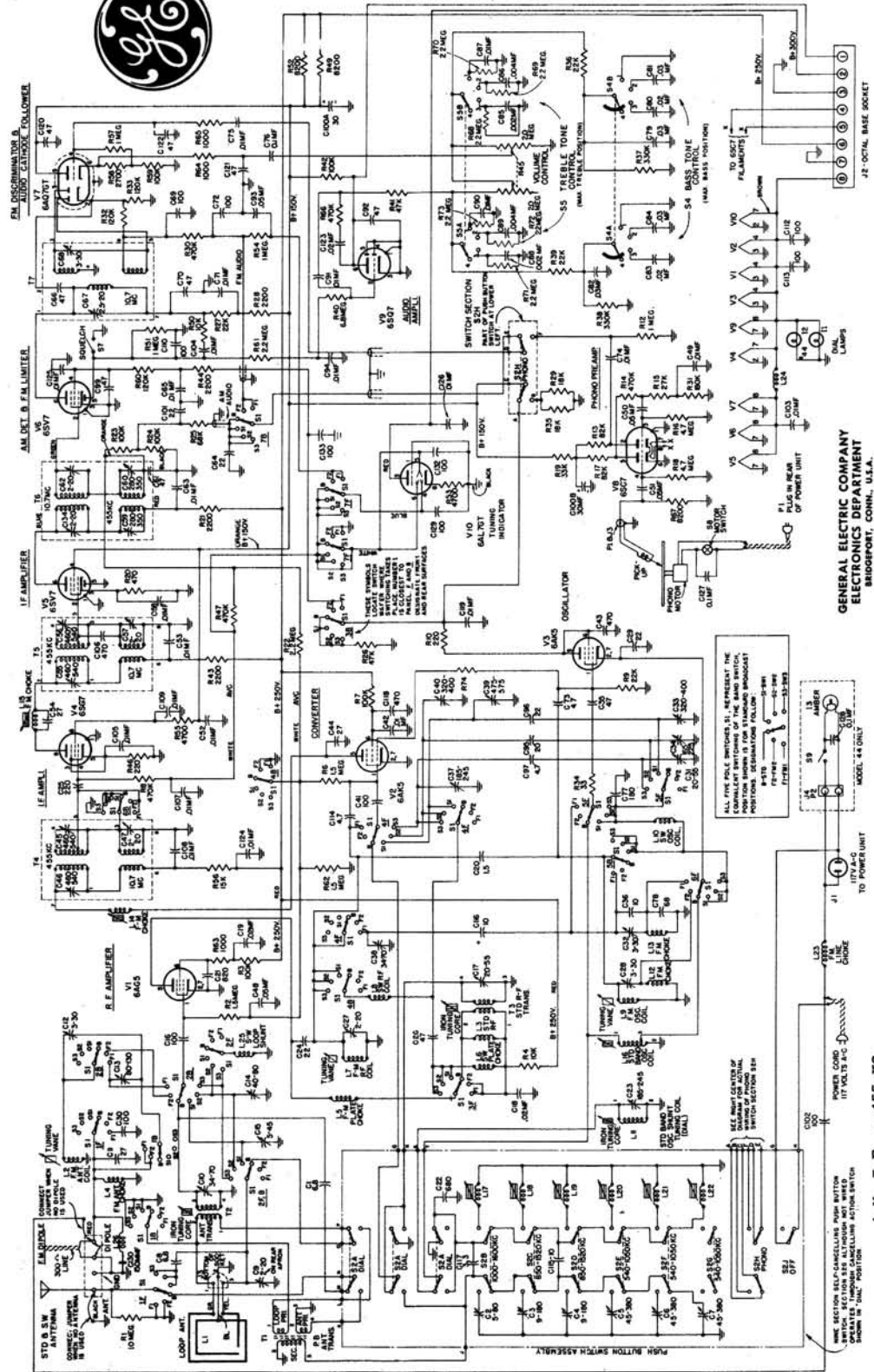

GENERAL ELECTRIC COMPANY
ELECTRONICS DEPARTMENT
SHELTON, CONN., U.S.A.

Schematic Diagram, Mouserhand Model 41 through 43

A.M. I.F. = 455 KC.
P.M. I.F. = 10.7 MC.

MANUAL OF 1948 MOST-OFTEN-NEEDED RADIO DIAGRAMS

GENERAL ELECTRIC

RADIO SERVICE DATA FOR

MODELS YRB 83-1, YRB 79-1, YRB 79-2

Rating: 105-125 volts d-c
105-125 volts 40-60 cycles a-c
28 watts at 117 volts

Tuning Frequency Range:540-1720 KC

Intermediate Frequency:455 KC

LOUDSPEAKER "ALNICO V" MAGNET DYNAMIC

Outside Cone Diameter.....5 1/4 in.
Voice Coil Impedance (400 cycles).....3.2 ohms

I.F. ALIGNMENT

Connect an output meter across the voice coil. Turn the volume control to maximum. Set test oscillator to 455 KC and keep the oscillator output as low as a readable meter reading will permit.

Apply signal to the converter grid through a .05 mfd capacitor and align progressively the trimmers in the 2nd and 1st I.F. transformer cans.

R.F. ALIGNMENT

Apply the R.F. alignment signals through a standard I.R.E. dummy antenna to the receiver antenna post. With the gang condenser wide open, align the oscillator trimmer (C17B) to 1720 KC. Change the generator signal to 1500 KC, tune the receiver to the signal and peak antenna trimmer (C17A) for maximum output.

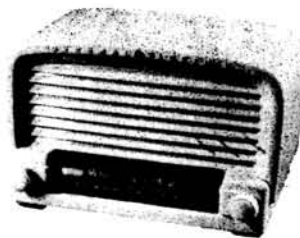

Model YRB 79-2

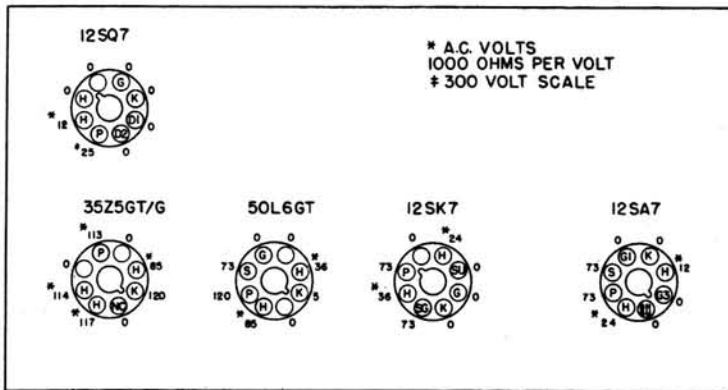
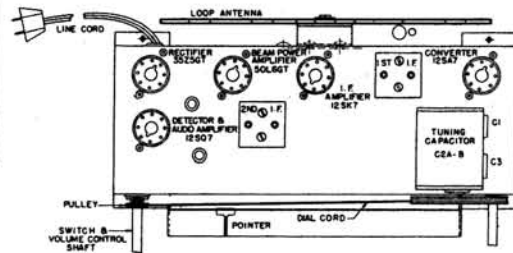

* A.C. VOLTS
1000 OHMS PER VOLT
300 VOLT SCALE

BOTTOM VIEW OF CHASSIS

LINE VOLTS - 117

VOL. CONT. MAX.

NO SIGNAL

Symbol	Description	Symbol	Description	Symbol	Description
C1	Antenna trimmer condenser	C14	.05 mfd paper capacitor	R1	22,000 ohm carbon resistor
C2A	Tuning condenser, antenna section	C15	.05 mfd paper capacitor	R2	2.2 megohm carbon resistor
C2B	Tuning condenser, oscillator section	C16	.05 mfd paper capacitor	R3	Volume control, .5 megohm
C3	Oscillator trimmer condenser	C17	.01 mfd paper capacitor	R4	4.7 megohm carbon resistor
C8	220 mmfd mica capacitor	L1	1st I.F. transformer	R5	470,000 ohm carbon resistor
C9	.005 mfd paper capacitor	L2	2nd I.F. transformer	R6	470,000 ohm carbon resistor
C10	220 mmfd mica capacitor	L3	Loop assembly	R7	150 ohm carbon resistor
C11	.01 mfd paper capacitor	L4	Oscillator coil	R8	2700 ohm carbon resistor
C12	.02 mfd paper capacitor	P1	Pilot lamp	R9	18 ohm carbon resistor
C13A	30 mfd electrolytic capacitor	T1	Output transformer	R10	470 ohm carbon resistor
C13B	30 mfd electrolytic capacitor				

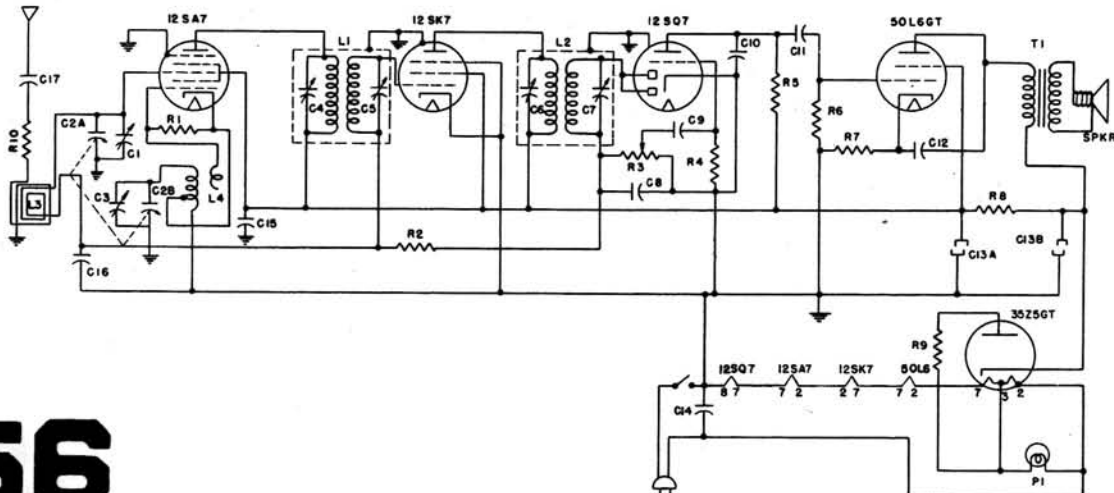

MANUAL OF 1948 MOST-OFTEN-NEEDED RADIO DIAGRAMS

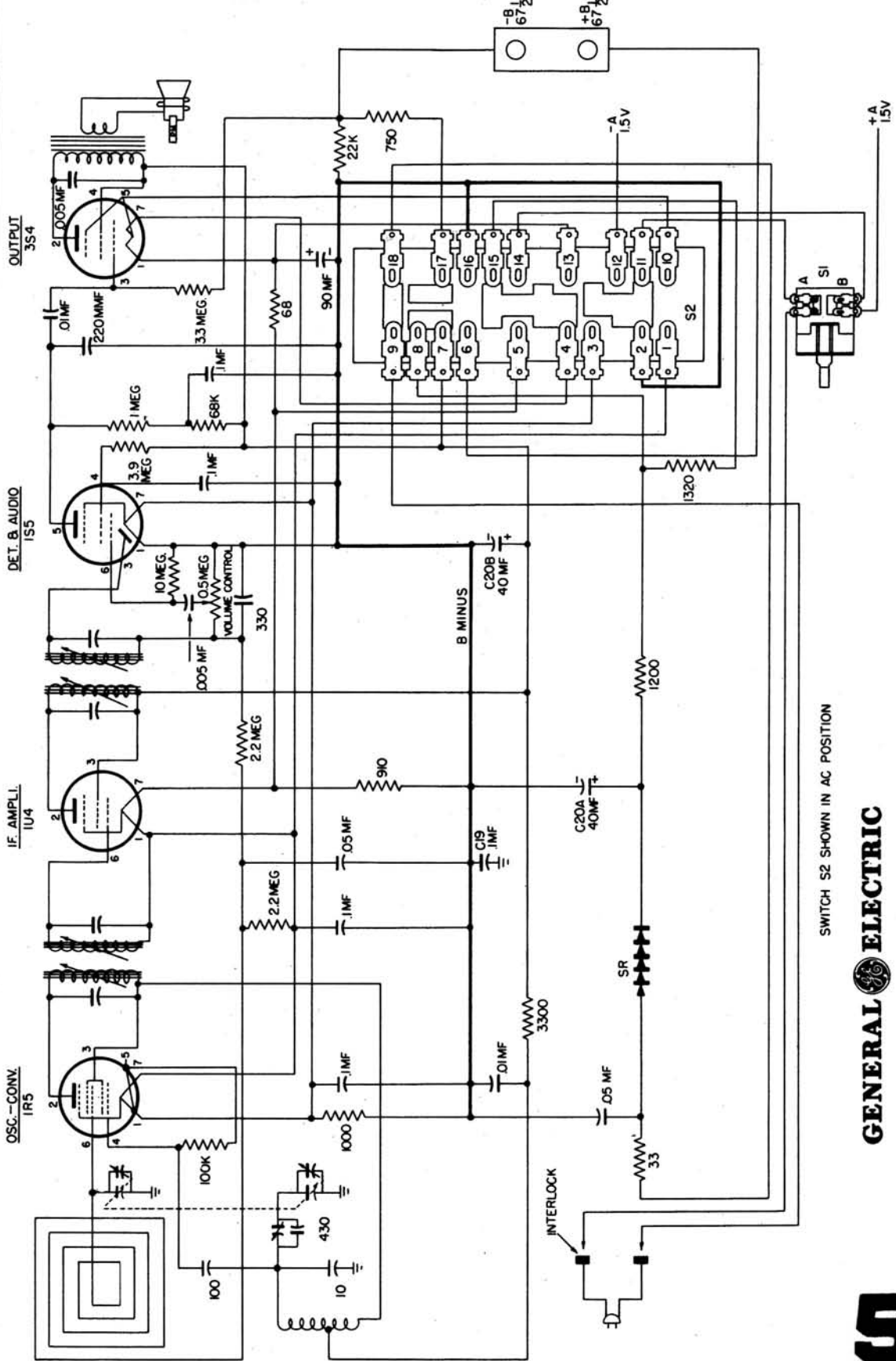

SWITCH S2 SHOWN IN AC POSITION

GENERAL ELECTRIC
RADIO
MODEL 140

ALIGNMENT FREQUENCIES

R-F 1620, 1500 and 580 kc
 I-F 455 kc

MANUAL OF 1948 MOST-OFTEN-NEEDED RADIO DIAGRAMS

GENERAL ELECTRIC

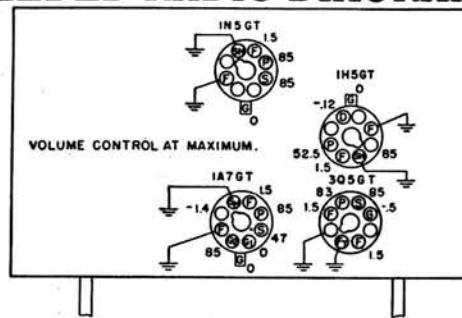
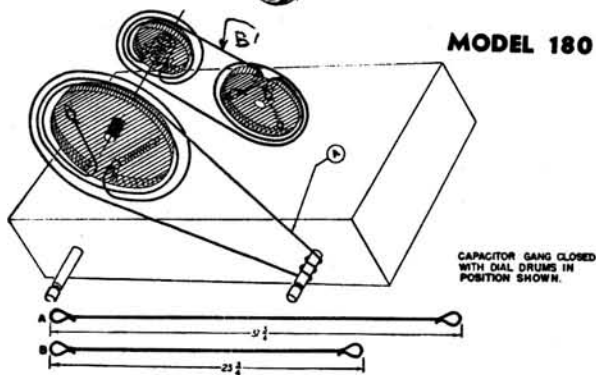

BOTTOM VIEW OF CHASSIS

MEASUREMENTS TAKEN ON 20,000 OHMS PER VOLT METER.
MEASURED FROM PIN TO CHASSIS.
1.5 V "A" - 90 V "B" BATTERY PACK. NO SIGNAL INPUT.

ALIGNMENT CHART

Step	Connect Test Oscillator To	Test Oscillator Setting	Pointer Setting On Radio	Adjust For Max. Output
1	1N5GT IF grid in series with .05 mfd.	455 KC	550 KC	1st IF trans. trimmers
2	1A7GT Conv. grid in series with .05 mfd.	455 KC	550 KC	2nd IF trans. trimmers
3	To Ant. Post through 200 mmf. dummy and to Grd. Post.	1500 KC	1500 KC	C7* (osc.) and C3 (R-F)

*Rock gang condenser when making alignment.

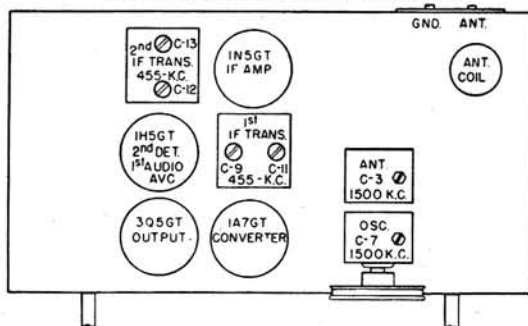

PART NO.	SYMBOL	DESCRIPTION
UCC-011	C4, 8, 10	CAPACITOR—.05 mfd., 200 v., paper
UCC-028	C16	CAPACITOR—.05 mfd., 400 v., paper
UCC-037	C20	CAPACITOR—.003 mfd., 600 v., paper
UCC-039	C15, 19	CAPACITOR—.005 mfd., 600 v., paper
UCC-040	C14	CAPACITOR—.01 mfd., 600 v., paper
UCU-1028	C6, 18	CAPACITOR—100 mmf., mica
UOP-629	SP	SPEAKER—6 1/2 in. permanent magnet
UOX-001		CONE—Replacement speaker cone
URD-037	R12	RESISTOR—330 ohm, 1/2 w., carbon
URD-065	R4	RESISTOR—4700 ohm, 1/2 w., carbon
URD-073	R1	RESISTOR—10,000 ohm, 1/2 w., carbon
URD-089	R5	RESISTOR—47,000 ohm, 1/2 w., carbon
URD-105	R3	RESISTOR—220,000 ohm, 1/2 w., carbon
URD-113	R7	RESISTOR—470,000 ohm, 1/2 w., carbon
URD-121	R10, 11	RESISTOR—1 meg., 1/2 w., carbon
URD-133	R2	RESISTOR—3.3 meg., 1/2 w., carbon
URD-137	R6	RESISTOR—4.7 meg., 1/2 w., carbon
URD-145	R9	RESISTOR—10 meg., 1/2 w., carbon
RCE-5001	C17	CAPACITOR—8 mfd., 150 v., electrolytic
RCT-5001	C5A, 5B	CAPACITOR—Tuning condenser
RCU-5002	C2	CAPACITOR—4.7 mmf., mica
RLA-5001	T2	COIL—Antenna coil
RLC-5001	T3	COIL—Oscillator coil
RRC-5001	R8, S3	VOLUME CONTROL—2 meg. vol. control and switch
RTL-5001	T5	TRANSFORMER—2nd i-f transformer
RTL-5002	T4	TRANSFORMER—1st i-f transformer

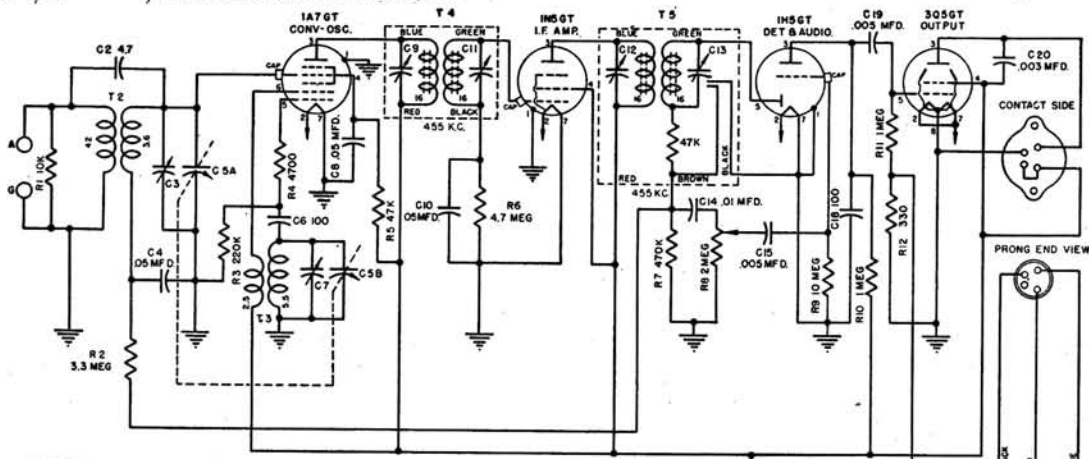

CAPACITY VALUES IN MMF UNLESS SPECIFIED
RESISTANCE VALUES IN OHMS
*K=1000, I., 22K=22,000

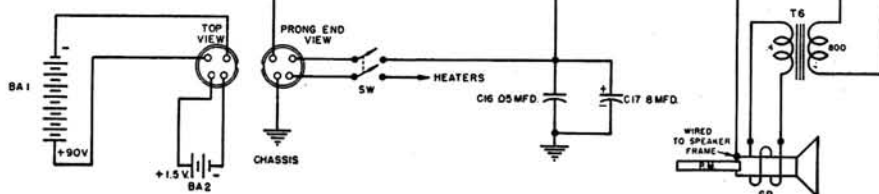

MANUAL OF 1948 MOST-OFTEN-NEEDED RADIO DIAGRAMS

GENERAL ELECTRIC

RADIO SERVICE DATA FOR MODEL 254



Stage gain by vacuum tube voltmeter or similar measuring devices may be used to check circuit performances and isolate trouble. The gain values listed may have tolerances of 20 per cent. Readings should be taken with low signal input so that the AVC is not effective.

- (1) **RF STAGE GAINS.**
 1N5GT i-f grid to 1A7GT grid 25 at 1000 kc
 1A7GT grid to 1N5GT i-f grid 25 at 1000 kc
 1A7GT grid to 1N5GT i-f grid 30 at 455 kc
 1N5GT i-f grid to 1H5GT diode plate 65 at 455 kc
- (2) **AUDIO GAIN.**
 .06 volt at 400 cycles across volume control (R17) with control set at maximum will give approximately .05 watt output across speaker voice coil.
- (3) **DC voltage developed across oscillator grid resistor (R6) averages 13 volts at 1000 kc.**

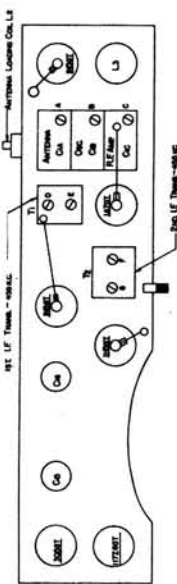

ALIGNMENT CHART

Step	Connect Test Oscillator to	Test Oscillator Setting	Pointer Setting on Radio	Adjustment for Maximum Output
1	1N5GT i-f grid in series with .05 mfd	455 kc	550 kc	2nd i-f Trns. (T2) Trimmers
2	1A7GT Conv. grid in series with .05 mfd	455 kc	550 kc	1st i-f Trns. (T1)
3	Repeat Steps 1 and 2			
4	Inductively coupled	1620 kc	Max. freq. cond. open	CIB OSC
5	Inductively coupled	1500 kc	1500 kc	C1A Ant. CIC RF
6	Inductively coupled	600 kc	600 kc	L2 Ant. Loading Coil
7	Inductively coupled	1500 kc	1500 kc	C1A Ant. CIC RF
8	Recheck Steps 5, 6, and 7			

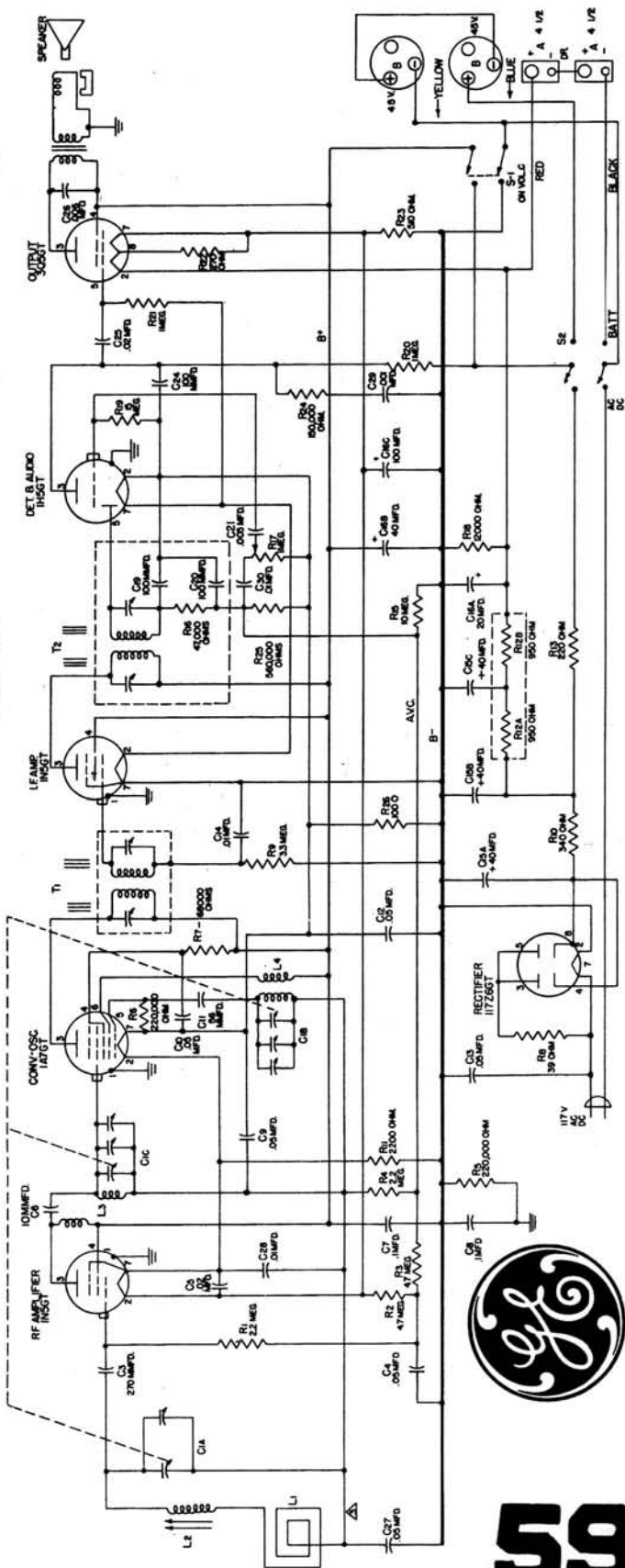

59

MANUAL OF 1948 MOST-OFTEN-NEEDED RADIO DIAGRAMS

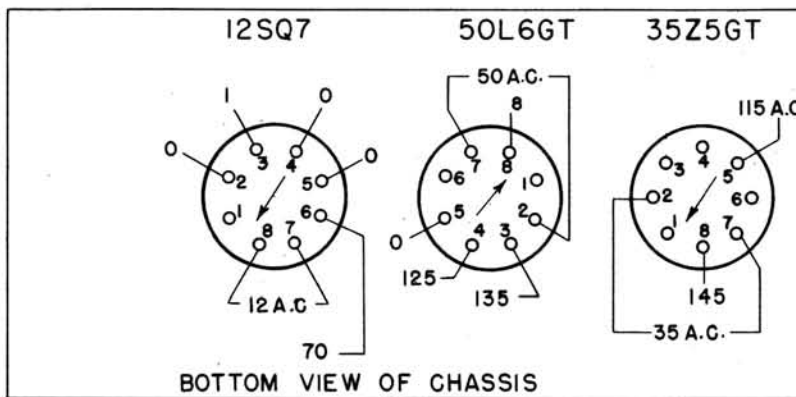
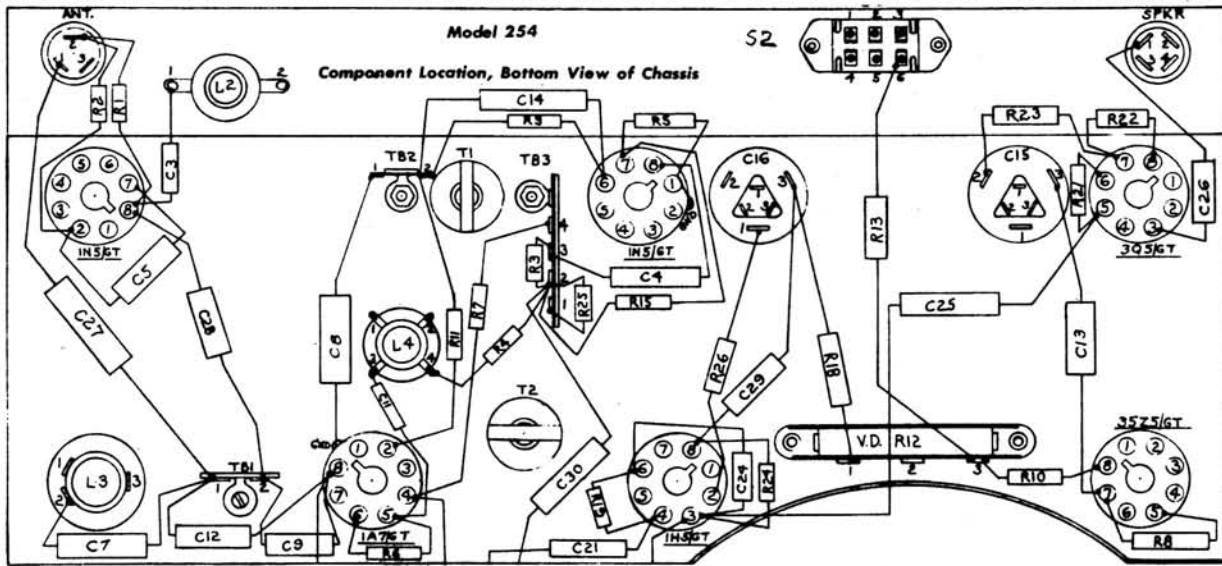

GENERAL ELECTRIC

SERVICE DATA
FOR
PORTABLE RECORD PLAYER
MODEL 15



CONDITIONS OF TEST

USE 1000 OHMS PER VOLT METER
ALL MEASUREMENTS TO B-
UNLESS SPECIFIED
LINE VOLTAGE — 115 V.A.C.

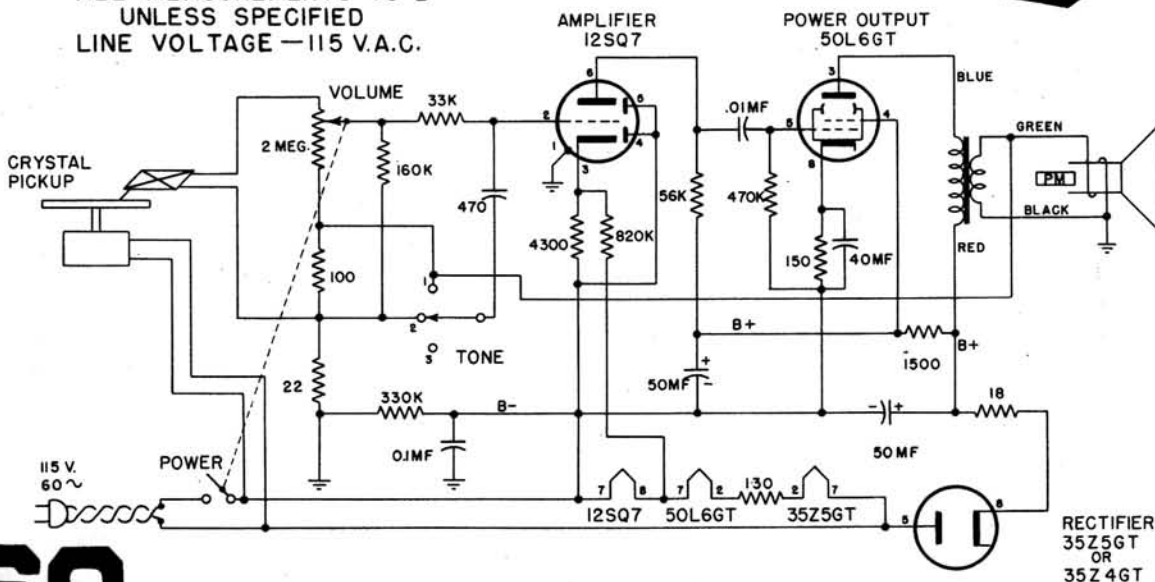

MANUAL OF 1948 MOST-OFTEN-NEEDED RADIO DIAGRAMS

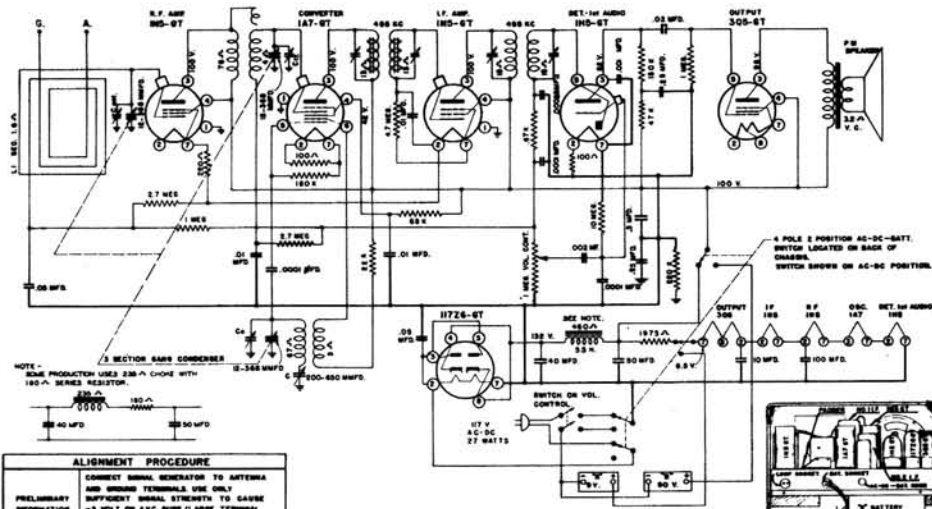

ALIGNMENT PROCEDURE

CONNECT SIGNAL GENERATOR TO ANTENNA AND OSC. TERMINALS USE ONLY SUFFICIENT SIGNAL STRENGTH TO GAIN -3 VOLT ON AVC BURE (LARGE TERMINAL OF LOOP PLATE) AS READ ON RCA VOLTMETER. ADJUST TUNE VOLTAGES ON CONTROLS.

STEPS	TUNE TEST	TUNE RADIO	DIAL TO	MAXIMUM READING
1	455 KC	CONDENSER BARR FULLY WOUND SET POINTER HORIZONTAL	IF TRANSFORMERS T1 AND T2	OSC TRIMMER C ₆ R.F. TRIMMER C11 SET TRIMMER C14H
2	1600 KC	1600 KC		PAGE 6 C WHILE POOLING BARR
3	800 KC	800 KC		
4	REPEAT STEP 2			
5	MOVE POINTER SLIGHTLY IF CALIBRATION CAN BE IMPROVED			



THE OVERLAND-MODEL 66B
SERIES 2

THIS RADIO IS SUPPLIED WITH COMBINATION A-B BATTERY PACK. FOR YOUR CONVENIENCE AN EXTRA BATTERY CABLE MAY BE OBTAINED FROM YOUR DEALER SO THAT YOU MAY MAKE BATTERY REPLACEMENTS BY MEANS OF SEPARATE "A" AND "B" BATTERIES. YOUR GILFILLAN PORTABLE RADIO HAS BEEN ESPECIALLY DESIGNED TO GIVE 200-300 HOURS OF BATTERY LIFE WHEN USED ON BATTERIES AN AVERAGE OF 4 HOURS PER DAY WHEN OPERATED ON A.C. OR D.C. HOUSE CURRENT YOUR BATTERIES ARE NOT USED.

MPN	A-B PAGES NO.	"A" BATTERIES NO.	"B" BATTERIES NO.
GENERAL	60A-60B-6	3W3	V50A OR F50A
EVEREST	60B60	4B	52B
EVEREST	60B60	52B	52B
BAT-D-VAC	4800A	P58A	P480
PHILCO	P641A	P160	P510

General TELEVISION and RADIO CORP.

MODEL No. 23 A 6

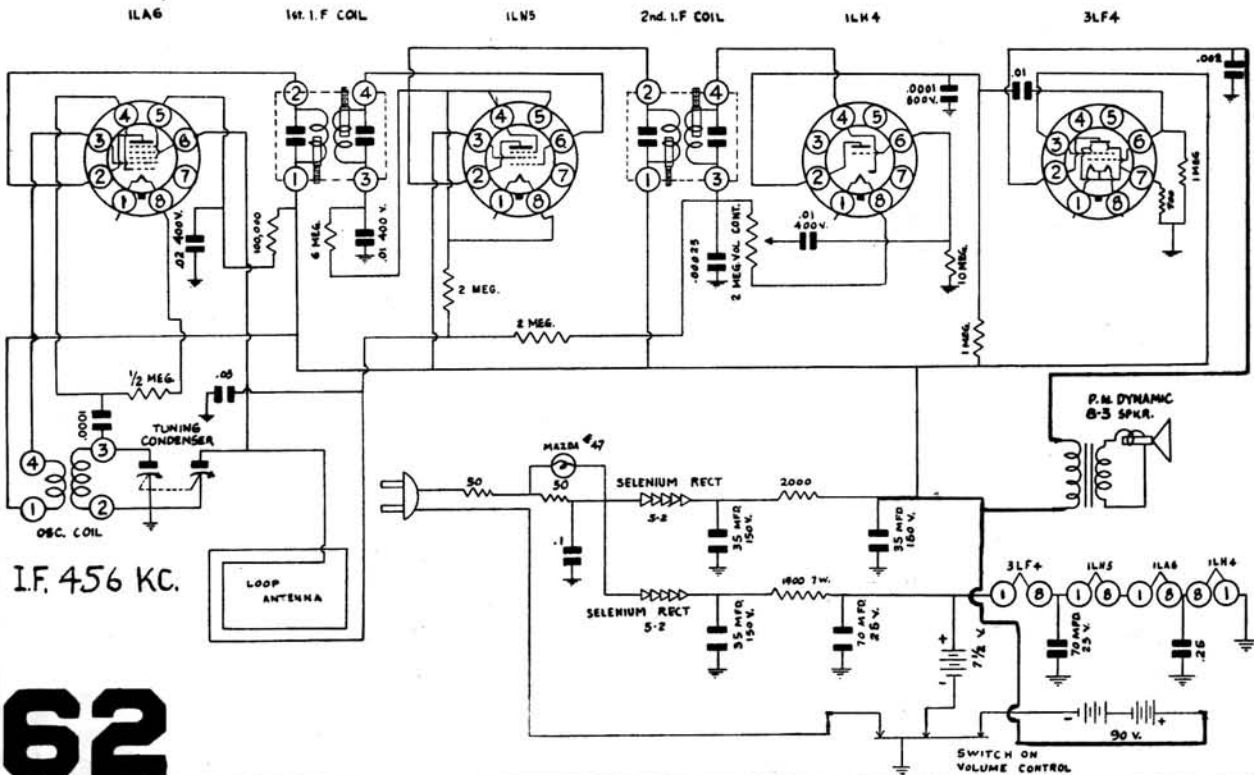

MANUAL OF 1948 MOST-OFTEN-NEEDED RADIO DIAGRAMS

Mantola

Models R662
R662N

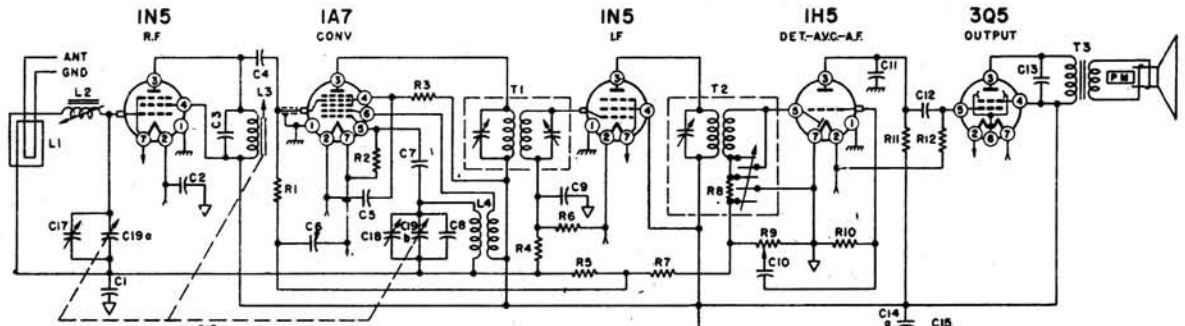

▽ COMMON LINE CONNECTION (B-)
⊕ CHASSIS GROUND

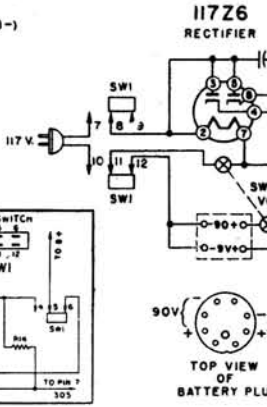
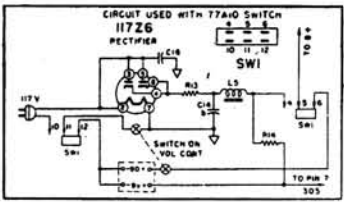
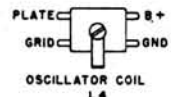

INTERMEDIATE FREQUENCY: 455 K C

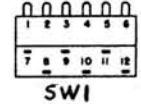

NOTES: I.F.=455 Kilocycles
Power change switch (SW1) shown in battery operation position.
In some models, loop loading coil (L2) was fixed.

CONDENSERS

Symbol	Description	Part No.
C1	.05 Mfd., 200 Volt, Paper	64B1-32
C2	.25 Mfd., 200 Volt, Paper	64B1-28
C3	.00042 Mfd., Mica	65B1-9
C4, C11	.00025 Mfd., Mica	65B5-22
C5, C6, C9,	.01 Mfd., 400 Volt, Paper	64B1-25
C10, C12	.00005 Mfd., Mica	65B5-11
C7	.000015 Mfd., Mica	65B5-3
C8	.002 Mfd., 600 Volt, Paper	64B1-14
C13	50 Mfd., 150 Volt	Elect. 67C7-42
C14a	30 Mfd., 150 Volt	Cond.
C14b	100 Mfd., 25 Volt	
C14c	2 Mfd., 400 Volt, Paper	64A2-1
C15	.2 Mfd., 400 Volt, Paper	64A2-2
C16	.05 Mfd., 400 Volt, Paper	64B1-22
C17	Antenna Trimmer	66A12-5
C18	Oscillator Trimmer (Part of Gang)	
C19	{ C19a } Condenser, Gang	68B4
	{ C19b }	

RESISTORS

Symbol	Description	Part No.
R6	4.7 Megohms, 1/2 Watt, Carbon	60B2-475
R7	3.3 Megohms, 1/2 Watt, Carbon	60B2-335
R8	50,000 Ohms, 1/2 Watt, Carbon	60B8-503
R9	1 Megohm Volume Control	75B1-100
R10	15 Megohms, 1/2 Watt, Carbon	60B2-156
R11	1 Megohm, 1/2 Watt, Carbon	60B2-105
R12	2.2 Megohms, 1/2 Watt, Carbon	60B2-225
R13	22 Ohms, Wire Wound, 1/2 Watt	61A2-2
R14	2,450 Ohms, Wire Wound, 5 Watt	61A3-5
R16	1,500 Ohms, 1/2 Watt, Carbon	60B8-152
R17	560 Ohms, 1/2 Watt, Carbon	60B8-561
R18	220 Ohms, 1/2 Watt, Carbon	60B8-221
R19	120 Ohms, 1/2 Watt, Carbon	60B8-121

COILS & TRANSFORMERS

Symbol	Description	Part No.
T2	2nd I.F. Transformer	72B10-2
T3	Transformer, Output	*
SW1	{ Switch, Power Change (R662)	77A6
	{ Switch, Power Change (R662N)	77A10

MISCELLANEOUS

Description	Part No.
Dial Background	21A18-2
Dial Cord, 12"	50A1-3
Dial Cord Tension Spring	19A1-2
Escutcheon and Dial Scale	23C14
Knob, Tuning	33A14-6
Knob, Volume	33A14-5
Plug, Battery (9 prong)	88A3-3
Pointer, Cream Tenite	25A15-1
Speaker & Output Transformer	78B8
Tube Shields	87A8

RESISTORS

R1	100,000 Ohms, 1/2 Watt, Carbon	60B8-104
R2	220,000 Ohms, 1/2 Watt, Carbon	60B8-224
R3	47,000 Ohms, 1/2 Watt, Carbon	60B8-473
R4, R5	4.7 Megohms, 1/2 Watt, Carbon	60B2-475

COILS & TRANSFORMERS

L2	{ Coil, Loop Loading, (fixed)	AA114
	{ Coil, Loop Loading, (variable)	AA115
L3	{ Iron Slug for plate coil	71B1-3
	{ Coil, Plate	70A1-30
L4	Oscillator Coil	69A7
L5	Choke Filter	74A5
T1	1st I.F. Transformer	72B9-2

VOLTAGE CHART

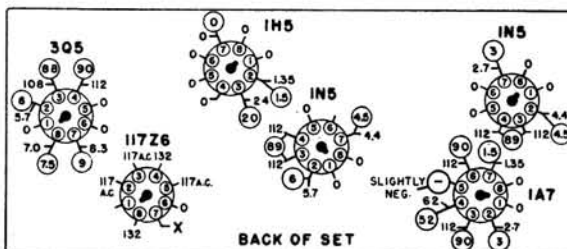

VOLTAGE DATA

1. Voltage readings circled (O) are for Battery Operation.
2. All readings made between Tube Socket Terminals and Terminal No. 7 on the 117Z6 (Point "X" on Voltage Chart).
3. A.C. Voltages measured on a 117 Volt A.C. line.
4. Battery Voltages measured with a fresh battery.
5. Dial turned to low frequency end, no signal.
6. All Voltages measured with a 1000 ohm-per-volt meter.

THE B. F. GOODRICH CO.

63

MANUAL OF 1948 MOST-OFTEN-NEEDED RADIO DIAGRAMS

the hallicrafters co.

MODEL S-38

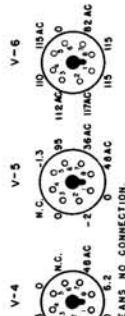
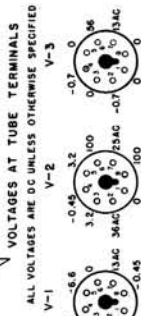
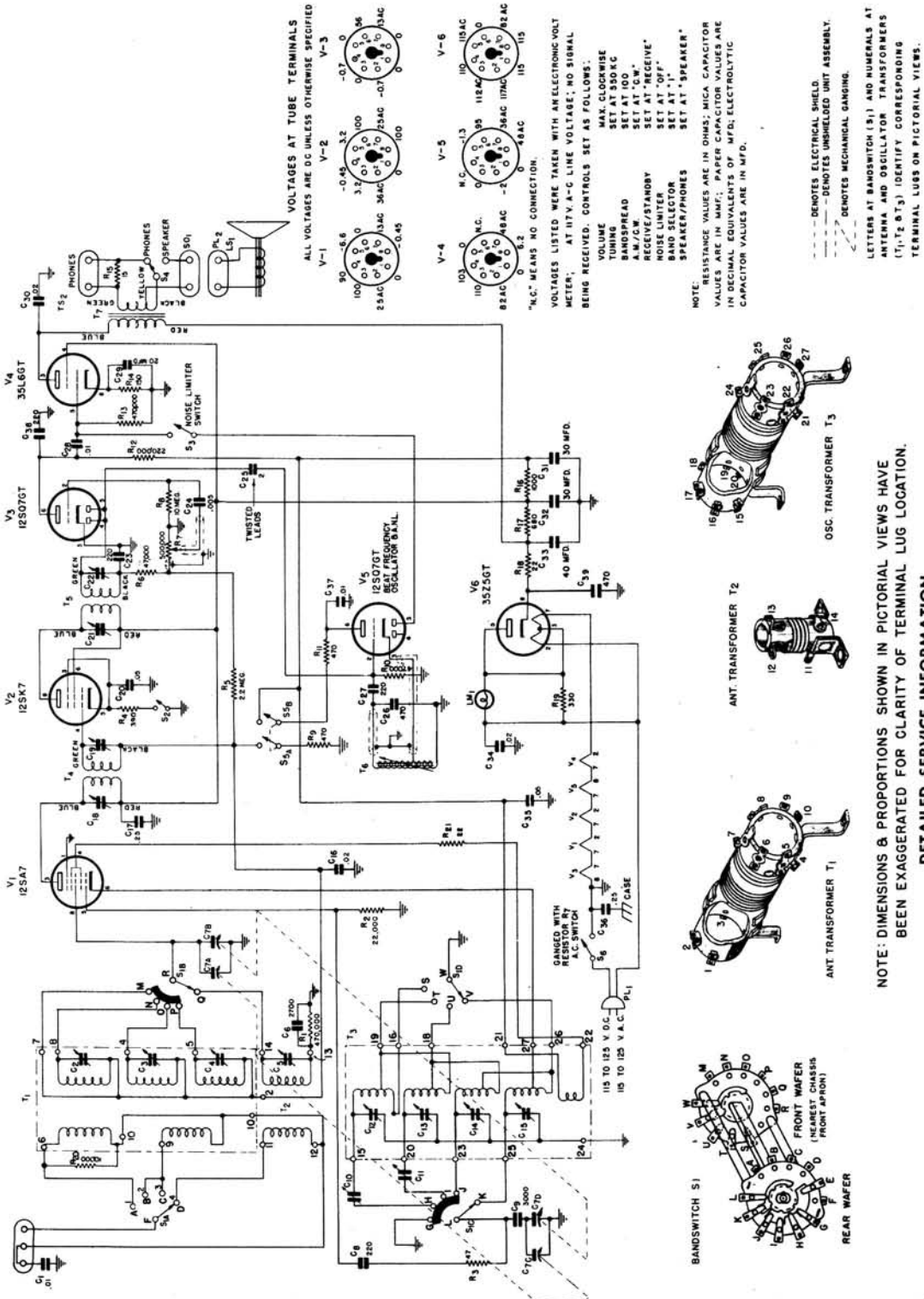

VOLUME
MAX. CLOCKWISE
SET AT 100 KC
BANDSPREAD
A.M./G.W.
RECEIVE/STANDBY
NOISE LIMITER
BAND SELECTOR
SPEAKER/PHONES

NOTE: RESISTANCE VALUES ARE IN OHMS; MICA CAPACITOR VALUES ARE IN DECIMAL EQUIVALENTS OF MFD; ELECTROLYTIC CAPACITOR VALUES ARE IN MFD.

--- DENOTES ELECTRICAL SHIELD
- - - - - DENOTES UNSHIELDED UNIT ASSEMBLY.
- - - - - DENOTES MECHANICAL GROUNDING.

LETTERS AT BANDSWITCH (S1) AND NUMERALS AT ANTENNA AND OSCILLATOR TRANSFORMERS (T1, T2, T3) IDENTIFY CORRESPONDING TERMINAL LUGS ON PICTORIAL VIEWS.

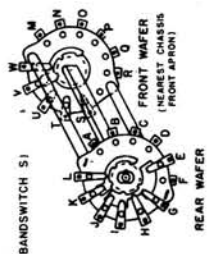
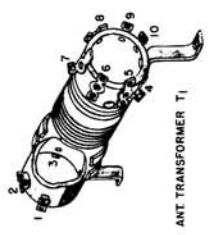
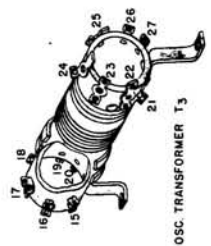

NOTE: DIMENSIONS & PROPORTIONS SHOWN IN PICTORIAL VIEWS HAVE BEEN EXAGGERATED FOR CLARITY OF TERMINAL LUG LOCATION.

DETAILED SERVICE INFORMATION

IF FREQUENCY	IF SELECTIVITY	IMAGE RATIO	SENSITIVITY	AUDIO OUTPUT
455 kc	7 kc wide at 6 db down 65 kc wide at 60 db down (for 50 milliwatt output)	2.7:1 at 30 mc 6:1 at 1.4 mc 10:1 at 5 mc 35:1 at 1500 kc	12 microvolt at 600 kc 1.2 microvolt at 1.4 mc 1.1 microvolt at 1.4 mc 2.3 microvolt at 30 mc (for 50 milliwatt output)	675 milliwatt with less than 10% distortion at 400 cycles

MANUAL OF 1948 MOST-OFTEN-NEEDED RADIO DIAGRAMS

the hallicrafters co. MODELS EC-306 AND EX-306

66

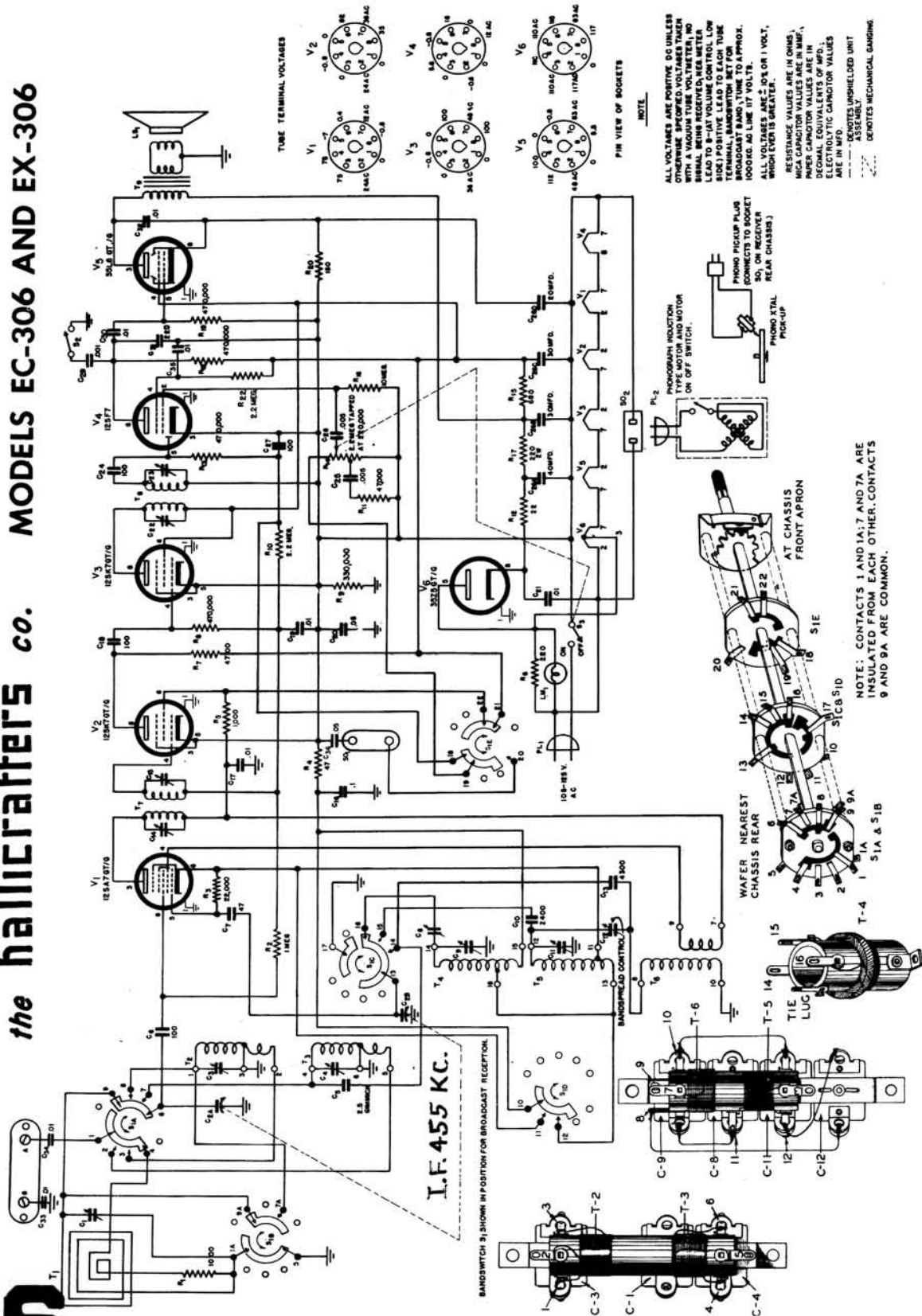

TUBE TERMINAL VOLTAGES

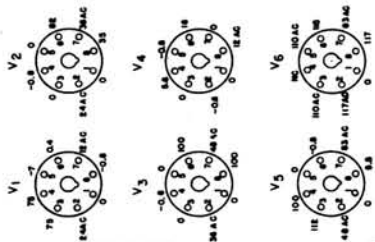

PIN VIEW OF SOCKETS

NOTE
 ALL VOLTAGES ARE POSITIVE 50 UNLESS OTHERWISE NOTED. ALL VOLTAGES MEASURED WITH A VACUUM TUBE VOLTMETER. SIGNAL BEING RECEIVED. VOLUME CONTROL LEAD TO 8-INCH VOLUME CONTROL. LOW SIDE POSITIVE LEAD TO EACH TUBE SOCKET. BROADCAST BAND TUNE TO APPROX. 1000 KC. AS LINE 117 VOLTS. ALL VOLTAGES ARE 2.0% OR 1.0% LOWER. RESISTANCE VALUES ARE IN OHMS, PAPER CAPACITOR VALUES ARE IN MMF., DECIMAL EQUIVALENTS OF MFD., ELECTROLYTIC CAPACITOR VALUES ARE IN MFD. --- DENOTES UNSHIELDED UNIT ASSEMBLY --- DENOTES MECHANICAL DAMPING

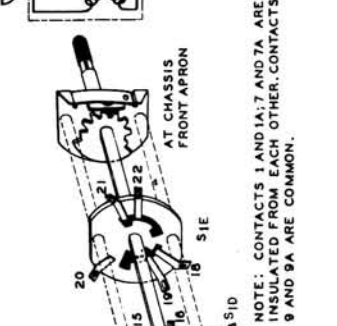
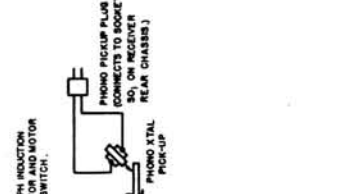

NOTE: CONTACTS 1 AND 1A; 7 AND 7A ARE INSULATED FROM EACH OTHER. CONTACTS 9 AND 9A ARE COMMON.

MANUAL OF 1948 MOST-OFTEN-NEEDED RADIO DIAGRAMS

OLYMPIC RADIO & TELEVISION

DIVISION OF
HAMILTON RADIO CORPORATION

Model 6-507

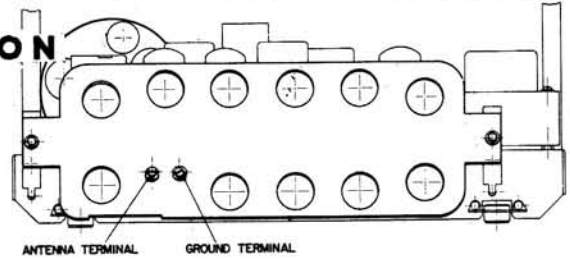
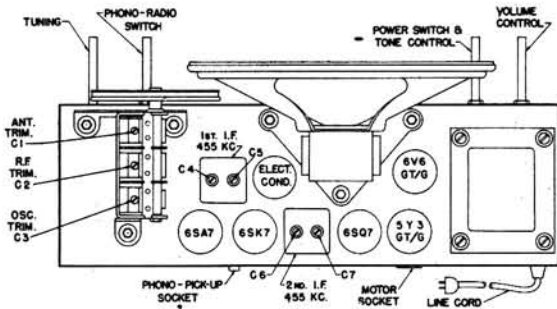

REAR VIEW OF RECEIVER CHASSIS WITH CABINET BACK REMOVED

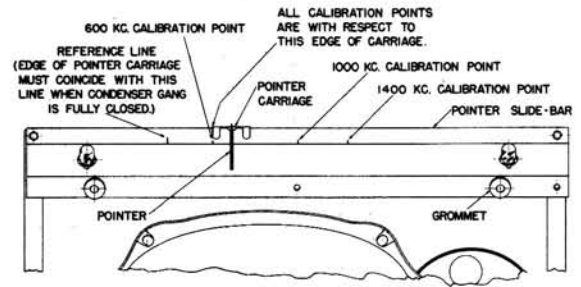

FRONT VIEW OF DIAL BACK-PLATE
SHOWING CALIBRATION POINTS

ALIGNMENT PROCEDURE CHART

STEP	CONNECT HIGH SIDE OF SIGNAL GENERATOR TO-	SET SIGNAL GENERATOR TO-	TURN POINTER TO-	ADJUST THE FOLLOWING FOR MAXIMUM OUTPUT. (KEEP SIGNAL FROM SIGNAL GENERATOR AS LOW AS POSSIBLE.)
1	R.F. SECTION OF THE VARIABLE CONDENSER.	455 KC.	EXTREME RIGHTHAND POSITION. (CONDENSER PLATES FULLY OPEN.)	C7, C6, C5, C4 AND REPEAT IN SAME ORDER (1st. AND 2nd. I.F. TRANSFORMERS.)
2	ANTENNA TERMINAL OF ANTENNA LOOP IN SERIES WITH 50 MMFD. COND.	1400 KC.	1400 KC. CALIBRATION POINT.	C3, C2, C1.
3		600 KC.	RESONANCE	CHECK THAT POINTER EDGE AT RESONANCE COINCIDES WITH 600 KC. CALIBRATION POINT. IF DEVIATION IS TOO LARGE REPEAT STEP 2.

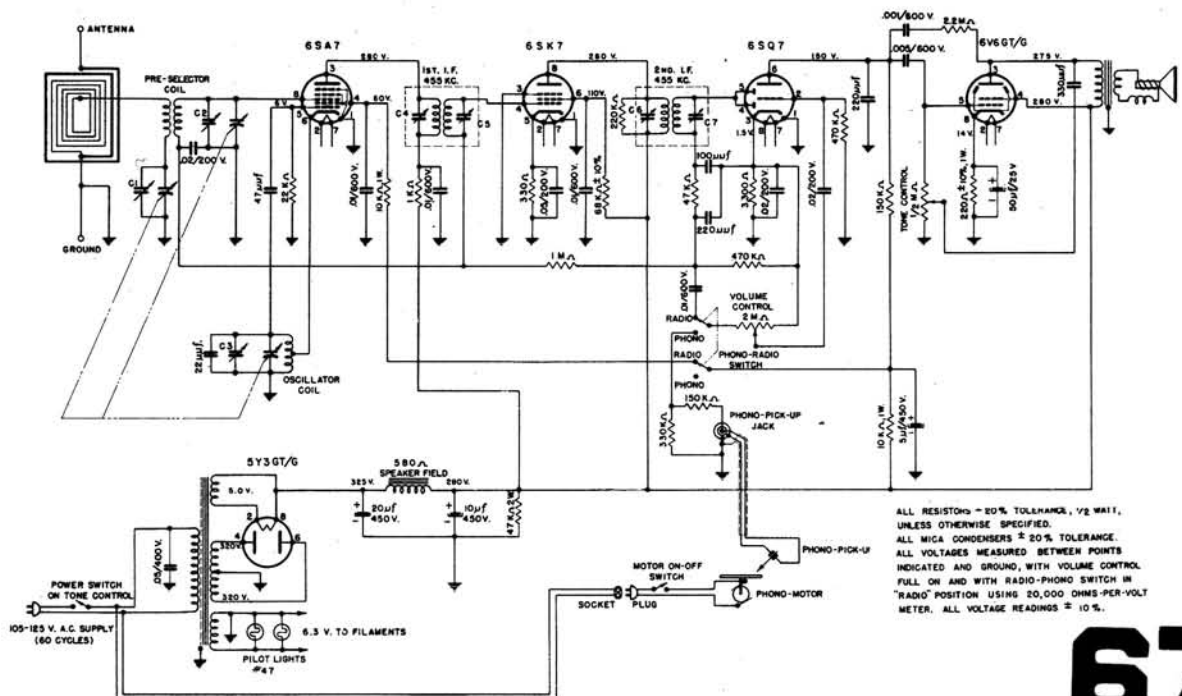

MANUAL OF 1948 MOST-OFTEN-NEEDED RADIO DIAGRAMS

Olympic Radio & Television
Hamilton Radio Corp.

Models 6-608-110 & 6-608-220

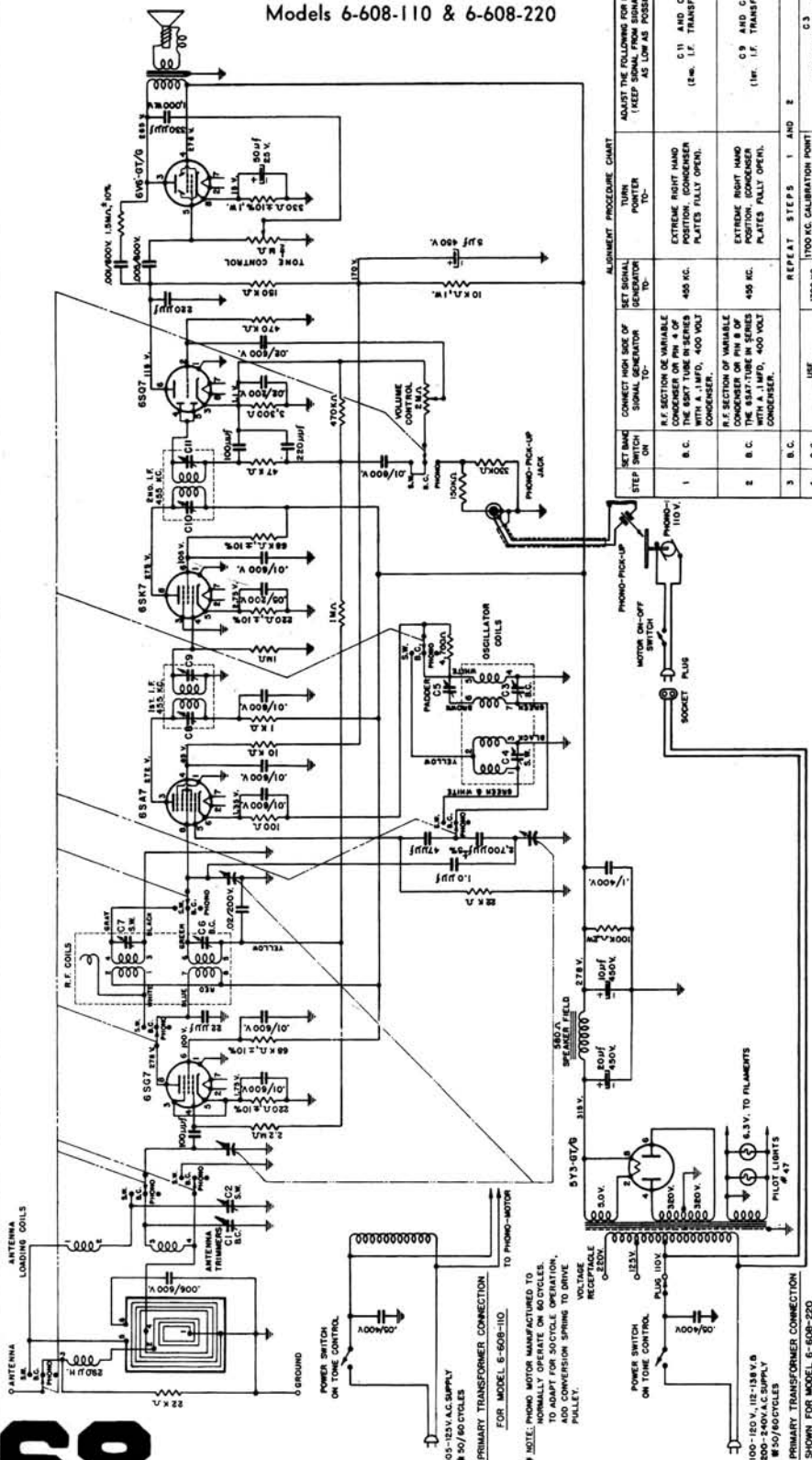

ALIGNMENT PROCEDURE CHART

STEP	SET BNC SIGNAL GENERATOR ON	CONNECT HIGH SIDE OF SIGNAL GENERATOR TO:	SET SIGNAL GENERATOR TO:	TUNE POWER TO:	ADJUST THE FOLLOWING FOR MAXIMUM OUTPUT (KEEP SIGNAL FROM SIGNAL GENERATOR AS LOW AS POSSIBLE).
1	B.C.	R.F. SECTION OF VARIABLE CONDENSER ON PH. 4 OF THE 6S7 TUBE IN SERIES WITH A .1MFD., 400 VOLT CONDENSER.	455 KC.	EXTREME RIGHT HAND POSITION. (CONDENSER PLATES FULLY OPEN).	C 11 AND C 10 (2nd. I.F. TRANSFORMER)
2	B.C.	R.F. SECTION OF VARIABLE CONDENSER ON PH. 8 OF THE 6S7-TUBE IN SERIES WITH A .1MFD., 400 VOLT CONDENSER.	455 KC.	EXTREME RIGHT HAND POSITION. (CONDENSER PLATES FULLY OPEN).	C 9 AND C 8 (1st. I.F. TRANSFORMER)
3	B.C.	USE RADIATED SIGNAL (CONNECT BOTH SIDES TO SIGNAL GENERATOR IN RADIATION LOOP).	1700 KC.	1700 KC. CALIBRATION POINT ON DIFFUSER PLATE.	C 3 (OSCILLATOR TRIMMER)
4	B.C.		1400 KC.	1400 KC. CALIBRATION POINT ON DIFFUSER PLATE.	C 6 AND C 1 (R.F. AND ANTENNA TRIMMERS)
5	B.C.		600 KC.	600 KC. CALIBRATION POINT ON DIFFUSER PLATE.	C 5 (PADDER)
6	B.C.		18 MC.	18 MC. CALIBRATION POINT ON DIFFUSER PLATE.	C 7 (R.F. TRIMMER)
7	B.C.		6 MC.	6 MC. CALIBRATION POINT ON DIFFUSER PLATE.	C 8 (ANTENNA TRIMMER)
8	S.W.		18 MC.	18 MC. CALIBRATION POINT ON DIFFUSER PLATE.	C 2 (MUSIC BRASS TRIMMER) SECOND PEAK FROM TIGHT POSITION.
9	S.W.		6 MC.	6 MC. CALIBRATION POINT ON DIFFUSER PLATE.	C 3 (ANTENNA TRIMMER) CHECK THAT POINTER (AT RESONANCE) COINCIDES WITH 6 MC. CALIBRATION POINT.
10	S.W.				REPEAT STEPS 8 AND 9.

NOTE: In order to adjust the short wave oscillator trimmer accurately to the fundamental frequency and not to the image signal, turn the trimmer first to the maximum capacity position (fully tight). From this position loosen the trimmer through one peak indication on the output meter until a second peak is obtained. Adjust for maximum output on this second peak.

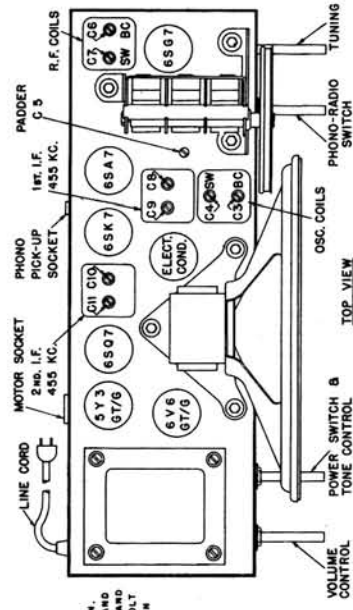

NOTES:

- RESISTORS ±20% TOLERANCE, 1/2 WATT, UNLESS OTHERWISE SPECIFIED.
- ALL MICA CONDENSERS ±20% TOLERANCE, UNLESS OTHERWISE SPECIFIED.
- BAND SELECTOR SWITCH SHOWN IN BROADCAST POSITION. ALL VOLTAGES MEASURED BETWEEN POINTS INDICATED AND GROUND, WITH YOUR METER COMMON LEAD TO GROUND. METER, WITH 1000 Ω RESISTOR IN SERIES WITH AN INPUT VOLTAGE OF 117 V., 60 CYCLES, A.C.
- TERMINAL NUMBERS ON ANTENNA LOOP CORRESPOND WITH TERMINAL LUGS ON LOOP ON BACK OF CHASSIS.

MANUAL OF 1948 MOST-OFTEN-NEEDED RADIO DIAGRAMS

OLYMPIC RADIO

Hamilton Radio Corp.

Model 7-526

ALIGNMENT PROCEDURE CHART

STEP	CONNECT HIGH SIDE OF SIGNAL GENERATOR TO -	SET SIGNAL GENERATOR TO -	SET POINTER TO -	ADJUST THE FOLLOWING FOR MAXIMUM OUTPUT. (KEEP SIGNAL FROM SIGNAL GENERATOR AS LOW AS POSSIBLE.)
1	R.F. SECTION OF VARIABLE CONDENSER IN SERIES WITH .1 MFD. COND.	455 KC.	EXTREME RIGHT HAND POSITION. (CONDENSER PLATES FULLY OPEN)	C8, C7, C6, C5 AND REPEAT IN SAME ORDER (1st. AND 2nd. I.F. TRANSFORMERS.)
2	USE RADIATED SIGNAL	1500 KC.	1500-KC. (150 ON DIAL)	C2, C3, C1 (OSCILLATOR, R.F. AND ANTENNA TRIMMERS)
3	(CONNECT BOTH SIDES OF SIGNAL GENERATOR TO RADIATION LOOP).	600 KC.	600 KC. (APPROX. 60 ON DIAL)	C4 (PADDER) ROCK DIAL FOR MAXIMUM SIGNAL
4				REPEAT STEPS 2 AND 3

POWER SWITCH & VOLUME CONTROL. 5 TUBE + RECT., 3 WAY (A.C.-D.C.-BATTERY) PORTABLE
 LINE VOLTAGE FOR POWER OPERATION: 105-125 VOLTS A.C., 50 TO 60 CYCLES
 OR 105-125 VOLTS D.C.

WATTAGE CONSUMPTION: 11 WATTS

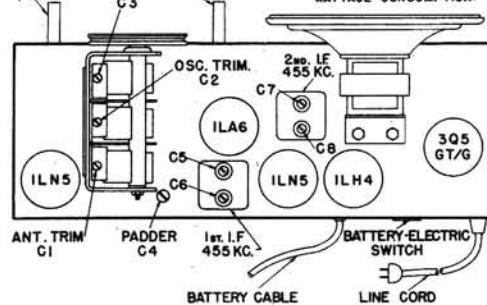

TOP VIEW OF CHASSIS

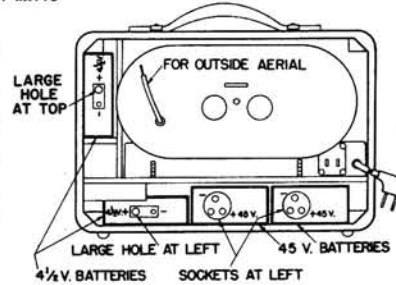

REAR VIEW OF CABINET
 SHOWING PLACEMENT OF BATTERIES

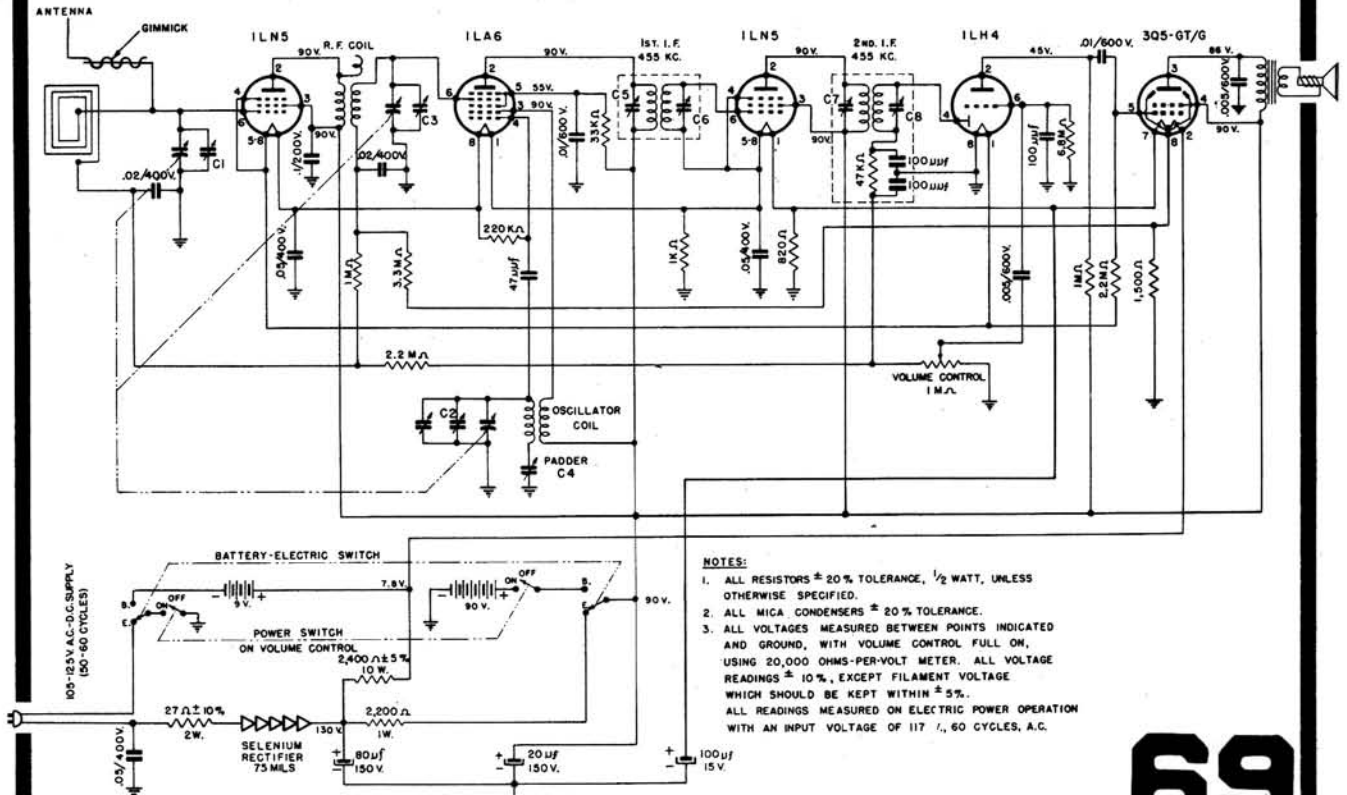

NOTES:

1. ALL RESISTORS $\pm 20\%$ TOLERANCE, $\frac{1}{2}$ WATT, UNLESS OTHERWISE SPECIFIED.
2. ALL MICA CONDENSERS $\pm 20\%$ TOLERANCE.
3. ALL VOLTAGES MEASURED BETWEEN POINTS INDICATED AND GROUND, WITH VOLUME CONTROL FULL ON, USING 20,000 OHMS-PER-VOLT METER. ALL VOLTAGE READINGS $\pm 10\%$, EXCEPT FILAMENT VOLTAGE WHICH SHOULD BE KEPT WITHIN $\pm 5\%$. ALL READINGS MEASURED ON ELECTRIC POWER OPERATION WITH AN INPUT VOLTAGE OF 117 V., 60 CYCLES, A.C.

MANUAL OF 1948 MOST-OFTEN-NEEDED RADIO DIAGRAMS

Hoffman

RADIO CORP.

MODEL A300
CHASSIS 100
CHASSIS 100S

Hoffman Model A300 with Chassis number 100S is electrically identical with Chassis number 100 except for the following:

1. Five-inch P.M. speaker, part number 9003, has been substituted for 4 x 6 inch oval dynamic speaker, part number 9000.
2. A 1500-ohm resistor, part number 4701, has been connected in the filter circuit in place of the 1500-ohm speaker field.

These changes have been incorporated in the schematic diagram shown below.

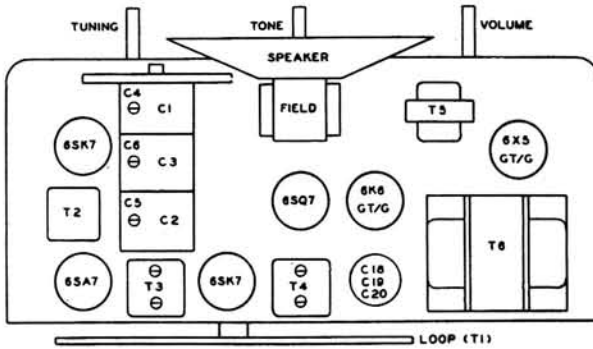

SYMBOL	DESCRIPTION	HOFFMAN NO
C1-C2-C3	Three-Section Variable (388-388-180 Mmf.)	4400
C4, C5, C6	Trimmers; Part of Variable Condenser	
C7, C8	.05 Mfd, 200 Volt, Tubular Paper	4100
C9, C12, C13, C15	100 Mmf ±20%, Mica	4000
C10, C11	.05 Mfd, 400 Volt, Tubular Paper	4101
C14, C16	.005 Mfd, 600 Volt, Tubular Paper	4102
C17	.01 Mfd, 600 Volt, Tubular Paper	4103
C18-C19-C20	Dry Electrolytic Condenser (20-20-20 Mfd 450-450-25 Volt)	4200
C21	.001 Mfd, 600 Volt, Tubular Paper	4104
C22	.01 Mfd, 600 Volt, Tubular Paper (Metal Can)	4105
L1	Oscillator Coil	5200
L5	5" PM Loudspeaker	9003
R1, R8	.22 Megohm ±20%, ½ Watt	4500
R2	22,000 Ohm ±20%, ½ Watt	4501
R3	2.2 Megohm ±20%, ½ Watt	4502
R4	10,000 Ohm ±10%, 2 Watt	4503
R5	47,000 Ohm ±20%, ½ Watt	4504
R6	.5 Megohm Potentiometer (Volume)	4800
R7	10 Megohm ±20%, ½ Watt	4505
R9	.47 Megohm ±20%, ½ Watt	4506
R10	560 Ohm ±10%, ½ Watt	4507
R11	.25 Megohm Potentiometer With Switch (Tone)	4801
R12	47 Ohm ±20%, ½ Watt	4508
R13	330 Ohm ±20%, ½ Watt	4509
R14	1500 Ohm ±10%, 10 Watt, W.W.	4702
S1	On-Off Switch (On Tone Control)	
T1	Antenna Loop	5201
T2	R.F. Coil (Shielded)	5202
T3	Input I.F. Transformer (455 K.C.)	5203
T4	Output I.F. Transformer (455 K.C.)	5204

PIN NO.	1	2	3	4	5	6	7	8
6SK7 (R.F.)	0	0	0	-.5	0	+85	6.1 A.C.	+227
6SA7	0	0	+227	+85	-7	0	6.1 A.C.	-.7
6SK7 (I.F.)	0	0	0	-.7	0	+85	6.1 A.C.	+227
6SQ7	0	-.5	0	-.25	0	+95	6.1 A.C.	0
6K6GT/G	0	0	+217	+227	0	+325 *	6.1 A.C.	+15
6X5GT/G	0	6.1 A.C.	290 A.C.	-	290 A.C.	-	0	+325

D.C. voltages measured with 20,000 ohm/volt meter.
A.C. voltages measured with 1,000 ohm/volt meter.
All voltages measured with reference to chassis.
Line voltage 117.5.

* Means tie point.

NOTE: The above readings are obtained with no signal input to the receiver.

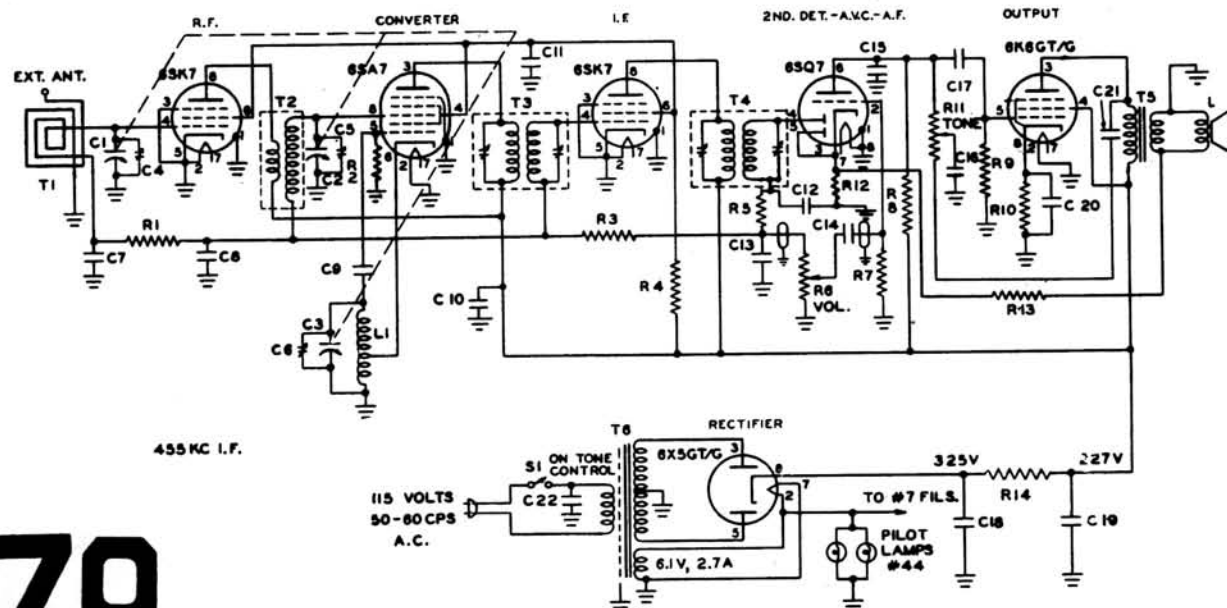

MANUAL OF 1948 MOST-OFTEN-NEEDED RADIO DIAGRAMS

Hoffman

RADIO CORP.

MODEL A700

CHASSIS 110S

I. F. Alignment

1. Connect output meter across speaker voice coil; set meter on 1-volt scale.
2. Connect output of signal generator to trimmer C3 (blue wire on trimmer located at rear of chassis). The ground side of the signal generator should be connected to B through a .1 Mfd. condenser. Set signal generator on 455 Kc (modulated).
3. Adjust I.F. trimmers (first T2 and then T1) for maximum reading on output meter.
NOTE: Keep signal level low, just enough to keep the maximum reading on the output meter at 0.4 volt or less. tuning gang should be set with plates all the way out; volume control full on.
4. Replace bottom cover plate.

R. F. Alignment

1. Leave tuning gang with plates all the way out.
2. Set signal generator on 1650 Kc (modulated) and feed generator output into a loop of wire approximately 6" in diameter. Place the loop about one foot away and parallel to the receiver loop antenna.
3. Tune in signal by adjusting oscillator trimmer C7.
4. Adjust output of signal generator to obtain deflection of .4 volt or less on output meter.
5. Adjust oscillator trimmer for maximum output.
6. Set signal generator to 1400 Kc and tune in signal with tuning condenser.
7. Adjust loop antenna trimmer C1 and R. F. Coil assembly for maximum output. The R. F. coil adjustment is made by loosening the coil mounting clamp and sliding the coil up or down as required.
8. Set signal generator and tuning gang to 600 Kc and adjust R. F. trimmer C3 for maximum output.
9. Go back to 1400 Kc to check tracking and readjust at 1400 Kc and 600 Kc as required.

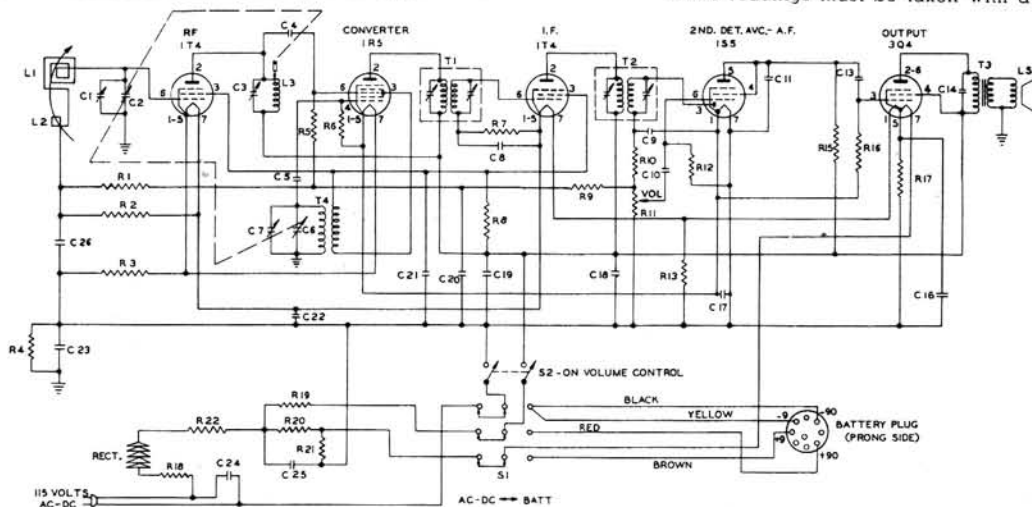
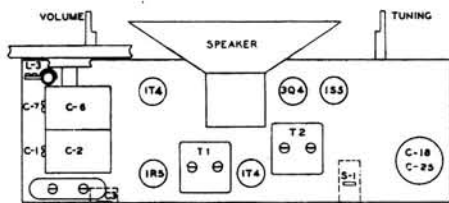

SYMBOL	DESCRIPTION	Hoffman No.
C1-C7	Trimners—Part of Variable Condenser	
C2-C6	Two Section Variable (388-180 Mmf.)	4401
C3	60-260 Mmf. Mica Trimmer	4306
C4-C9-C11	.0001 Mfd. Mica	4000
C5	47 Mfd. Mica	4009
C8-C26	.01 Mfd. 400 Volt Tubular Paper	4112
C10-C12- C13-C14	.005 Mfd. 600 Volt Tubular Paper	4102
C15-C16	100 Mfd. 25 Volt Dry Electrolytic	4204
C17-C19- C20-C21	.05 Mfd. 200 Volt Tubular Paper	4100
C18-C25	Dry Electrolytic Condenser (30-50 Mfd. 150-150 Volt)	4201
C22-C23	.2 Mfd. 200 Volt Tubular Paper	4108
C24	.05 Mfd. 400 Volt Tubular Paper	4101
L1	Antenna Loop	55208
L2	Antenna Loop Compensator	5250
L3	R.F. Coil Permeability Tuned	5245
L5	5 1/4" P.M. Speaker	9019
R1-R14	3.3 Megohm, 1/2 Watt	4535
R2-R7-R9- R16	2.2 Megohm, 1/2 Watt	4502
R3	680 Ohms, 1/2 Watt	4514
R4	.47 Megohm, 1/2 Watt	4506
R5-R15	1 Megohm, 1/2 Watt	4513
R6-R10	.1 Megohm, 1/2 Watt	4511
R8	3900 Ohms ± 10%, 1/2 Watt	4527
R11	1 Megohm Potentiometer with D.P.S.T. Switch (Volume)	4808
R12	10 Megohm, 1/2 Watt	4505
R13*	820 Ohm ± 10%, 1/2 Watt	4533
R17	1500 Ohm, 1/2 Watt	4534
R18-R22	47 Ohm, 2 Watt	4532
R19	1000 Ohm, 1 Watt	4522
R20	1500 Ohm, 6 1/2 Watt ± 5% Wirewound	4701
R21	470 Ohm, 1 Watt ± 10%	4531
S1	AC/DC Battery Switch Plug Operated	6010
S2	On-Off Switch (on Volume Control)	
T1	Input I.F. Transformer (455 K.C.)	5242
T2	Output I.F. Transformer (455 K.C.)	5243
T3	Output Audio Transformer	5104
T4	Oscillator Coil	5244
Rect.	Selenium Rectifier	9517

* Some sets use 1000 ohms ± 20%, 1/2 Watt, Part No. 4542.

The following table lists the normal operating voltages to be expected at the various socket terminals.

PIN NO.	1	2	3	4	5	6	7	8
1T4 (RF)	2.6	84	65		2.6		3.9	
1R5	1.3	84	64	-5.0*	1.3	3*	2.6	
1T4 (RF)	3.9	84	65	1.2*	3.9	1.5*	5.2	
1S5	1.3	0	.5*	20*	1	-.5*	0	
3Q4	5.2	84	-1.3*	84	6.5	84	7.8	

NOTE: All voltages are measured with reference to B- (black wires on volume control switch) and no signal input to receiver.

* These readings must be taken with a V. T. V. M.

MANUAL OF 1948 MOST-OFTEN-NEEDED RADIO DIAGRAMS

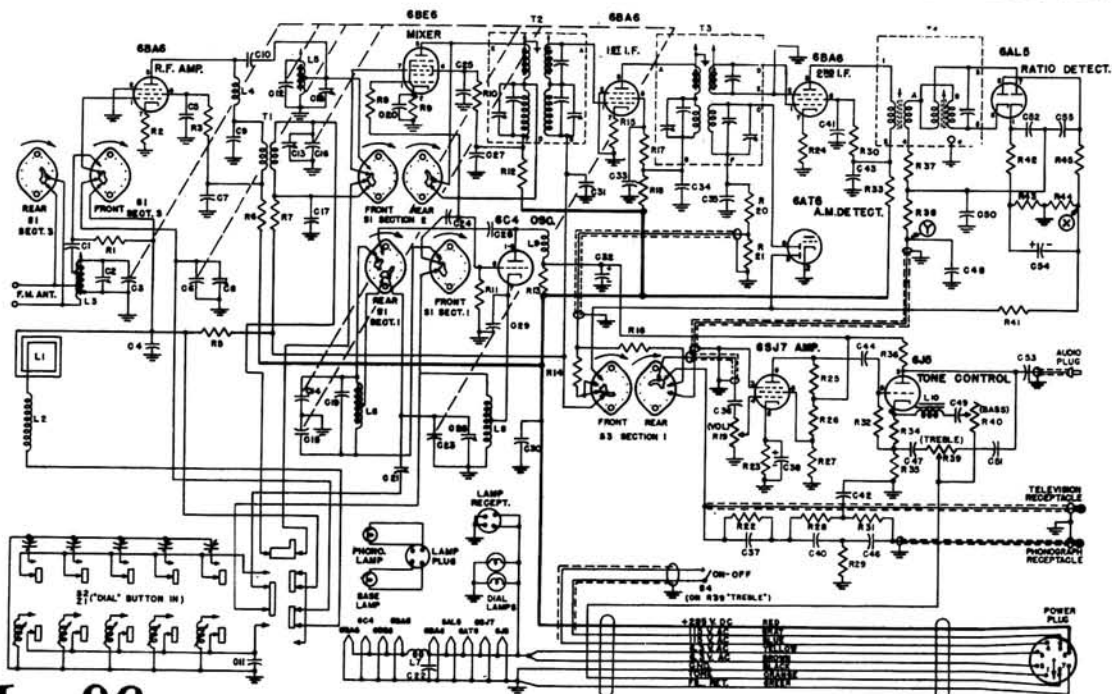

Tuner Schematic Diagram

Hoffman

RADIO CORP.

MODEL B502 CHASSIS 113

TUNING RANGES:
 Broadcast Band 535 Kc to 1650 Kc
 FM Band 88 Mc to 108 Mc
 INTERMEDIATE FREQUENCIES:
 Broadcast Band 455 Kc
 FM Band 10.7 Mc

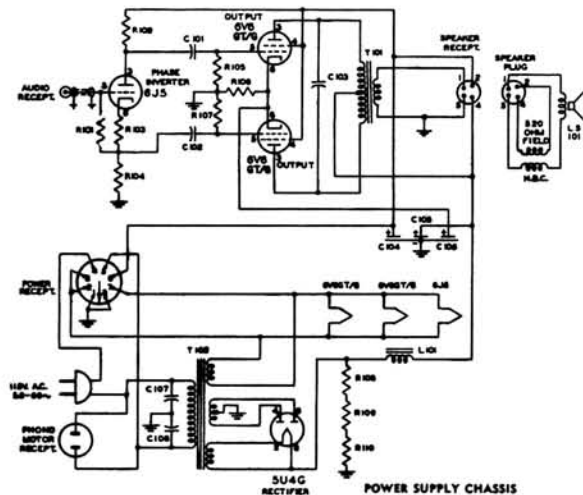

SYMBOL	DESCRIPTION	HOFFMAN NO.
C101, C102	.05 Mfd. 400 Volt Tub. Paper	4101
C103	470 Mmf. $\pm 20\%$ Mica	4003
C104, C105	20/20 Mfd. 450V. 20 Mfd. 25V. Electrolytic	4200
C106		
C107, C108	.01 Mfd. 600 Volt. Metal Case	4105
R101	1 Meg. $\pm 20\%$ $\frac{1}{2}$ Watt	4513
R102, R104	47000 Ohm $\pm 10\%$ $\frac{1}{2}$ Watt	4559
R103	2200 Ohm $\pm 20\%$ $\frac{1}{2}$ Watt	4512
R105, R107	.22 Meg. $\pm 20\%$ $\frac{1}{2}$ Watt	4500
R106	220 Ohm $\pm 20\%$ 3 Watt W.W.	4706
R108, R109	10,000 Ohm $\pm 10\%$ 2 Watt	4503
R110		
L101	Filter Choke	5116
T101	Audio Output Transformer	5108
T102	Power Transformer	5007
LS101	Speaker—12" Electrodynamic	9044

SYMBOL	DESCRIPTION	HOFFMAN NO.
C1, C9, C10, C28, C35, C37	100 Mmf. $\pm 10\%$ Ceramic	4012
C2, C18	1 - 8 Mmf. Trimmer	4315
C3, C6, C12, C14, C15, C16, C23	3 Sect. Variable with Split Stator	4408
C4, C17, C22, C31	.05 Mfd. 200 Volt Tub. Paper	4100
C5, C25	470 Mmf. $\pm 20\%$ Mica	4003
C7, C30, C34, C44, C51, C53	.01 Mfd. 400 Volt Tub. Paper	4112
C8, C13, C26	1.8 - 30 Mmf. Trimmer	4313
C11	500 Mmf. $\pm 5\%$ Silver Mica	4004
C19	50 Mmf. $\pm 2\%$ Ceramic	4023
C20	220 Mmf. $\pm 20\%$ Ceramic	4026
C21	110-560 Mmf. Trimmer	4301
C24	22 Mmf. $\pm 10\%$ Ceramic	4021
C27	5000 Mmf. (Min.) Ceramic	4029
C29	50 Mmf. $\pm 20\%$ Ceramic	4031
C32	20 Mfd. 450 Volt Electrolytic	4207
C33, C41	.001 Mfd. 600 Volt Tub. Paper	4104
C36	.02 Mfd. 400 Volt Tub. Paper	4106
C38	25 Mfd. 25 Volt Electrolytic	4205
C40, C46, C50, C52, C55	330 Mmf. $\pm 5\%$ Mica	4010
C42	650 Mmf. $\pm 5\%$ Mica	4011
C47	.005 Mfd. 600 Volt Tub. Paper	4102
C48	.002 Mfd. 600 Volt Tub. Paper	4118
C49	5 Mfd. 200 Volt Tub. Paper	4110
C54	5 Mfd. 50 Volt Electrolytic	4209
C43	2300 Mmf. $\pm 5\%$ Mica	4006
R1	.27 Meg. $\pm 20\%$ $\frac{1}{2}$ Watt	4545
R2, R9, R15, R24	56 Ohm $\pm 10\%$ $\frac{1}{2}$ Watt	4561
R3, R10, R17, R30	33,000 Ohm $\pm 20\%$ 1 Watt	4556
R5, R7	.1 Meg. $\pm 20\%$ $\frac{1}{2}$ Watt	4511
R6, R12, R18, R33	1500 Ohm $\pm 20\%$ $\frac{1}{2}$ Watt	4534
R8	22 Ohm $\pm 20\%$ $\frac{1}{2}$ Watt	4560
R11, R35, R36	22,000 Ohm $\pm 20\%$ $\frac{1}{2}$ Watt	4501
R13	4700 Ohm $\pm 20\%$ 2 Watt	4551
R14	2.2 Meg. $\pm 20\%$ $\frac{1}{2}$ Watt	4502
R16, R32	1 Meg. $\pm 20\%$ $\frac{1}{2}$ Watt	4513
R19	.5 Meg. Pot. (Volume)	4804
R20, R38	47,000 Ohm $\pm 20\%$ $\frac{1}{2}$ Watt	4506
R21	.68 Meg. $\pm 20\%$ $\frac{1}{2}$ Watt	4555
R22	4.7 Meg. $\pm 20\%$ $\frac{1}{2}$ Watt	4544
R23, R34	2200 Ohm $\pm 20\%$ $\frac{1}{2}$ Watt	4512
R25	.22 Meg. $\pm 20\%$ $\frac{1}{2}$ Watt	4500
R26	.12 Meg. $\pm 10\%$ $\frac{1}{2}$ Watt	4548
R27	15,000 Ohm $\pm 20\%$ $\frac{1}{2}$ Watt	4521
R28, R31	47,000 Ohm $\pm 10\%$ $\frac{1}{2}$ Watt	4559
R29	22,000 Ohm $\pm 5\%$ $\frac{1}{2}$ Watt	4538
R37	120 Ohm $\pm 10\%$ $\frac{1}{2}$ Watt	4546
R39	.25 Meg. Pot. With Switch (Treble)	4805
R40	50,000 Ohm Pot. (Bass)	4806
R41	.47 Meg. $\pm 20\%$ $\frac{1}{2}$ Watt	4506
R42, R45	390 Ohm $\pm 10\%$ $\frac{1}{2}$ Watt	4549
R43, R44	6800 Ohm $\pm 10\%$ $\frac{1}{2}$ Watt	4557
L1	Loop Antenna	55210
L2	Antenna Coil—Broadcast	5265
L3	Coil—F.M. Ant.	5253
L4, L9	Coil—F.F.	5254
L5	Coil—F.M. R.F.	5252
L6	Coil—F.M. Osc.	5251
L7	Coil—Fil. R.F.	5266
L8	Coil—B.C. Osc.	5263

MANUAL OF 1948 MOST-OFTEN-NEEDED RADIO DIAGRAMS

Hoffman

RADIO CORP.

MODEL B400

CHASSIS 118

I. F. ALIGNMENT:

1. Connect output meter across speaker voice coil; set meter on 2.5 volt scale.
2. Connect output of signal generator directly to antenna post on loop; connect ground side of generator to chassis of receiver through .1 Mfd. condenser. Set signal generator on 455 Kc (modulated).
3. Adjust I.F. trimmers (first T4 and then T3) for maximum reading on output meter.

R.F. ALIGNMENT:

1. Set tuning condenser with plates completely out.
2. Set signal generator at 1650 Kc (modulated) and feed its output into a loop of wire about 6" in diameter. Place this loop about one foot away from and parallel to the receiver loop antenna.
3. Tune in signal by adjusting oscillator trimmer (C4).
4. Adjust output of signal generator to obtain deflection on lower half of meter scale.
5. Adjust oscillator trimmer (C4) for maximum output.
6. Set signal generator at 1400 Kc and tune in signal with tuning condenser.
7. Adjust antenna trimmer (C3) while rocking gang condenser for maximum reading on output meter. Feed only enough signal from generator to keep maximum reading on lower half of meter scale.

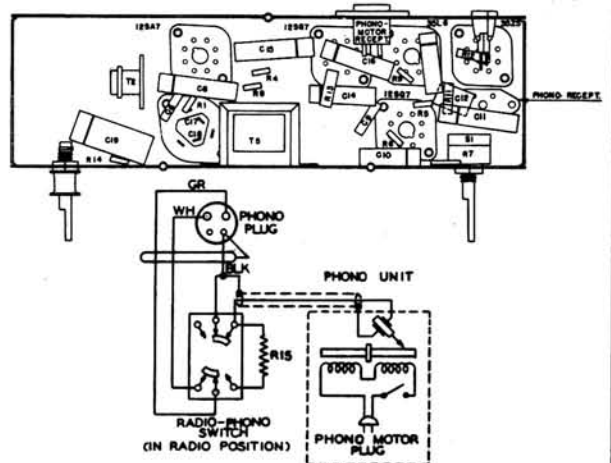
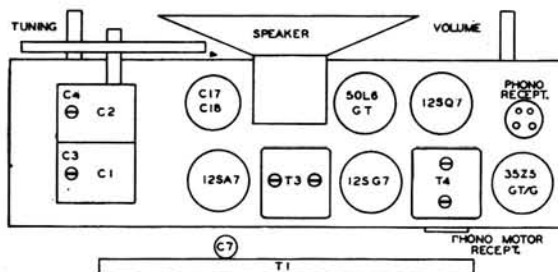

SYMBOL	DESCRIPTION	HOFFMAN No.
C1, C2	Two Section Variable (388-180 Mmf.)	4401
C3, C4	Trimmer; Part of Variable Cond.	
C6	100 Mmf. ±20% Mica	4000
C7, C10, C13	.005 Mfd. 600 Volt Tubular Paper	4102
C8, C11, C15	.05 Mfd. 200 Volt Tubular Paper	4100
C9, C12	270 Mmf. ±20% Mica	4001
C14	.02 Mfd. 400 Volt Tubular Paper	4106
C16	.05 Mfd. 400 Volt Tubular Paper	4101
C17, C18	Dry Electrolytic (50 30 Mfd. 150 V.)	4201
C19	.1 Mfd. 200 Volt Tubular Paper	4108
C20	.001 Mfd. 600 Volt Tubular Paper	4104
R1	22,000 Ohm ±20% 1/2 Watt	4501
R4	2.2 Megohm ±20% 1/2 Watt	4502
R5	47,000 Ohm ±20% 1/2 Watt	4504
R6, R8	10 Megohm ±20% 1/2 Watt	4505
R7	.5 Megohm Pot. with Switch (Vol.)	4802
R9	.22 Megohm ±20% 1/2 Watt	4500
R10, R14, R15	.47 Megohm ±20% 1/2 Watt	4506
R11	150 Ohm ±20% 1/2 Watt	4510
R12	47 Ohm ±20% 1/2 Watt	4508
R13	1500 Ohm ±20% 1 Watt	4552
S2	Phono-Radio-Tone Switch	6021
L5	PM Loudspeaker	9023
S1	On-Off Switch (on Vol. Control)	
T1	Antenna Loop	5255
T2	Oscillator	5208
T3	Input I.F. Transformer (455Kc.)	5205
T4	Output I.F. Transformer (455Kc.)	5206
T5	Audio Output Transformer	5117

PIN NO.	1	2	3	4	5	6	7	8
12SA7	0	24 A.C.	+85	+92	-5.5	0	11.5 A.C.	-4
12SG7	0	22 A.C.	0	-4	0	+92	36 A.C.	+86
12SQ7	0	-8	0	0	-1.0	+60	0	9 A.C.
50L6	0	36 A.C.	+101	+93	+2	0	87 A.C.	+7.5
35Z5	0	117 A.C.	114 A.C.	+112	114 A.C.	0	87 A.C.	+116

D.C. voltages measured with 20,000 ohm/volt meter.
A.C. voltages measured with 1,000 ohm/volt meter.
All voltages measured with reference to B-.

NOTE: The above readings are obtained with no signal input to the receiver, radio-phono switch in the RADIO position, and volume control full on.

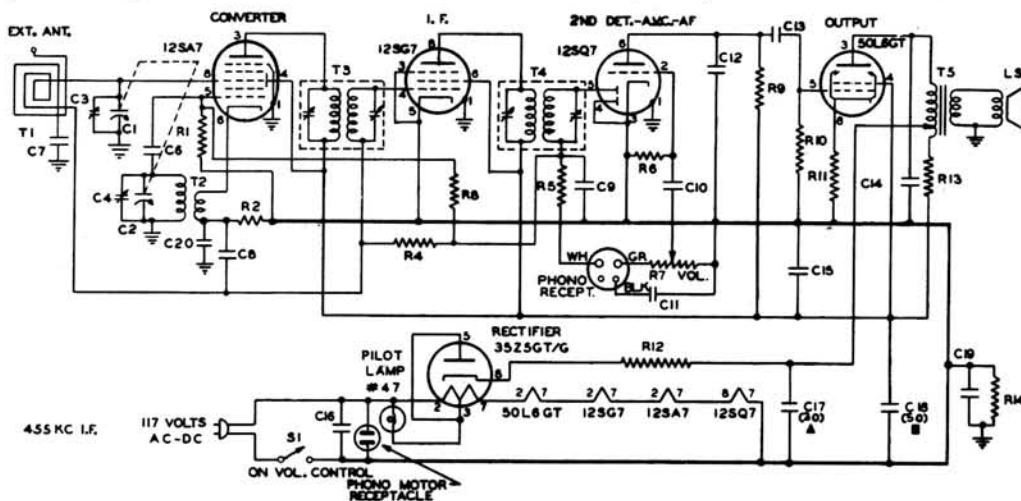

MANUAL OF 1948 MOST-OFTEN-NEEDED RADIO DIAGRAMS

Hoffman

RADIO CORP.

MODELS A202 & A309

CHASSIS 119

SYMBOL	DESCRIPTION	HOFFMAN No.
C1	.005 Mfd. 600 Volt Tubular Paper	4102
C2, C5	Dual Padder 280 Mmf. Per Section	4307
C3, C6	100 Mmf. ± 20% Mica	4000
C4	.05 Mfd. 400 Volt Tubular Paper	4101
C7, C8	100 Mmf. ± 10% Ceramic	4012
C9	.05 Mfd. 200 Volt Tubular Paper	4100
C10, C11	100 Mmf. ± 10% Ceramic	4012
C12	270 Mmf. ± 20% Mica	4001
C13, C15	Dry Electrolytic (30-50 Mfd./150 V)	4201
C14	.2 Mfd. 200 Volt Paper Tubular	4108
C16	.005 Mfd. 600 Volt Paper Tubular	4102
C17	270 Mmf. ± 20% Mica	4001
C18	.005 Mfd. 600 Volt Tubular Paper	4102
C19	.02 Mfd. 400 Volt Tubular Paper	4106
L5	5" PM Loudspeaker	9003
R1	2200 Ohm ± 20% ½ Watt	4512
R2, R6	47,000 Ohm ± 20% ½ Watt	4504
R3	22,000 Ohm ± 20% ½ Watt	4501
R4	47 Ohm ± 20% ½ Watt	4508
R5	2.2 Megohm ± 20% ½ Watt	4502
R7	10 Megohm ± 20% ½ Watt	4505
R8	.5 Megohm Pot. with Switch (Volume)	4802
R9	500 Ohm ± 10% 5 Watt	4700
R10, R12	.47 Megohm ± 20% ½ Watt	4506
R11	.22 Megohm ± 20% ½ Watt	4500
R13	150 Ohm ± 20% ½ Watt	4510

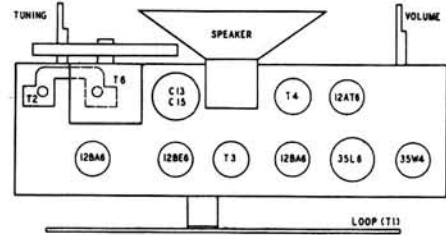
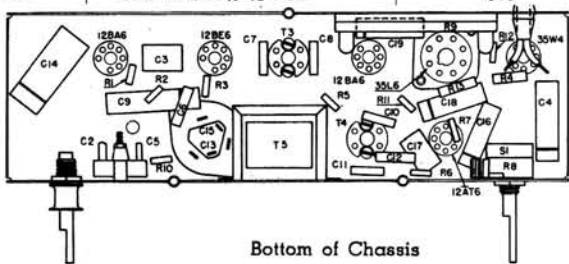

PIN NO.	1	2	3	4	5	6	7	8
12BA6 (R.F.)	— .45	0.	25. A.C.	37.5 A.C.	+65.	+80.	0.	
12BE6	4.6*	0.	12.5 A.C.	25. A.C.	+80.	+80.	0.	
12BA6 (I.F.)	— .45	0.	37.5 A.C.	50. A.C.	+80.	+80.	0.	
12AT6	—1.5*	0.	0.	12.5 A.C.	0.	—15.	+37.5	
35L6	0.	85 A.C.	+75 D.C.	+80. D.C.	0.	0.	50. A.C.	+4.6
35W4	115 A.C.	0.	85. A.C.	115. A.C.	110. A.C.	110. A.C.	+110. D.C.	

D.C. voltages measured with 1000 ohm/volt meter
 A.C. voltages measured with 1000 ohm/volt meter
 All voltages measured with reference to B-

* These readings taken with V. T.V. M.
 NOTE: The above readings are obtained with no signal input to receiver.

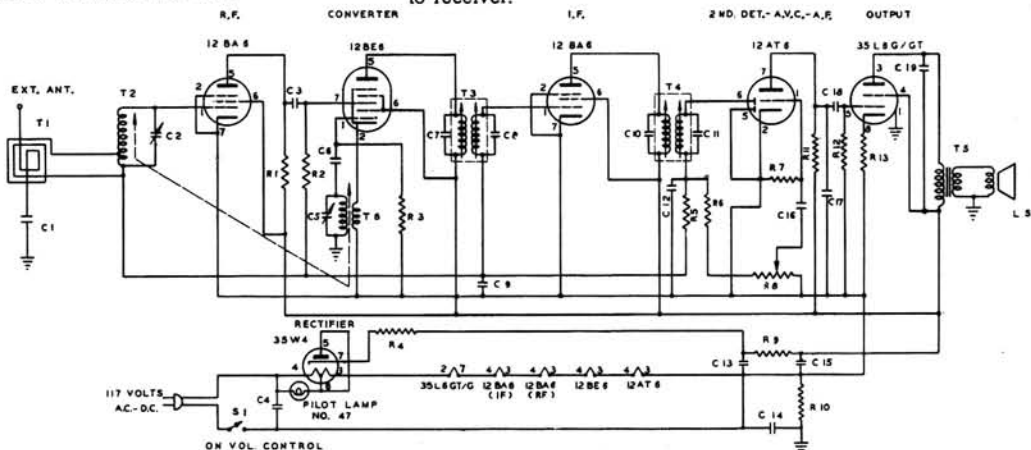

I.F. ALIGNMENT:

1. Connect output meter across speaker voice coil; set meter on 2.5 volt scale.
2. Connect output of signal generator directly to 12BE6 control grid; connect ground side of generator to chassis of receiver through .25 Mfd. condenser. Set signal generator on 455 Kc (modulated).
3. Adjust I.F. slugs (first T4 and then T3) for maximum reading on output meter.
 Note: Keep signal level low, just enough to keep maximum reading on lower half of meter scale. Tuning condenser plates should be all the way out; volume control should be on full. After adjustment, put a drop of wax on each I.F. tuning slug to hold it in place.

R.F. ALIGNMENT: control slugs

1. Set receiver tuning control with slugs all the way in.
2. Set signal generator on 540 Kc (modulated) and connect generator output to antenna post on receiver. The ground side of the generator should be connected to receiver B- through a .25 Mfd. condenser.
3. Tune in signal by adjusting oscillator trimmer C5.
4. Adjust output of signal generator to obtain deflection on lower half of meter scale.
5. Adjust oscillator trimmer for maximum output.
6. Set signal generator on 1650 Kc and check signal with tuning condenser plates all the way out.
7. Set signal generator on 1470 Kc.
8. Tune in signal on receiver and adjust rf trimmer C2 for maximum reading on output meter. Feed only enough signal from the generator to keep maximum reading on lower half of meter scale.
9. Recheck at 600 Kc, 1000 Kc and 1410 Kc for tracking and readjust as required.

1948 MOST-OFTEN-NEEDED RADIO DIAGRAMS

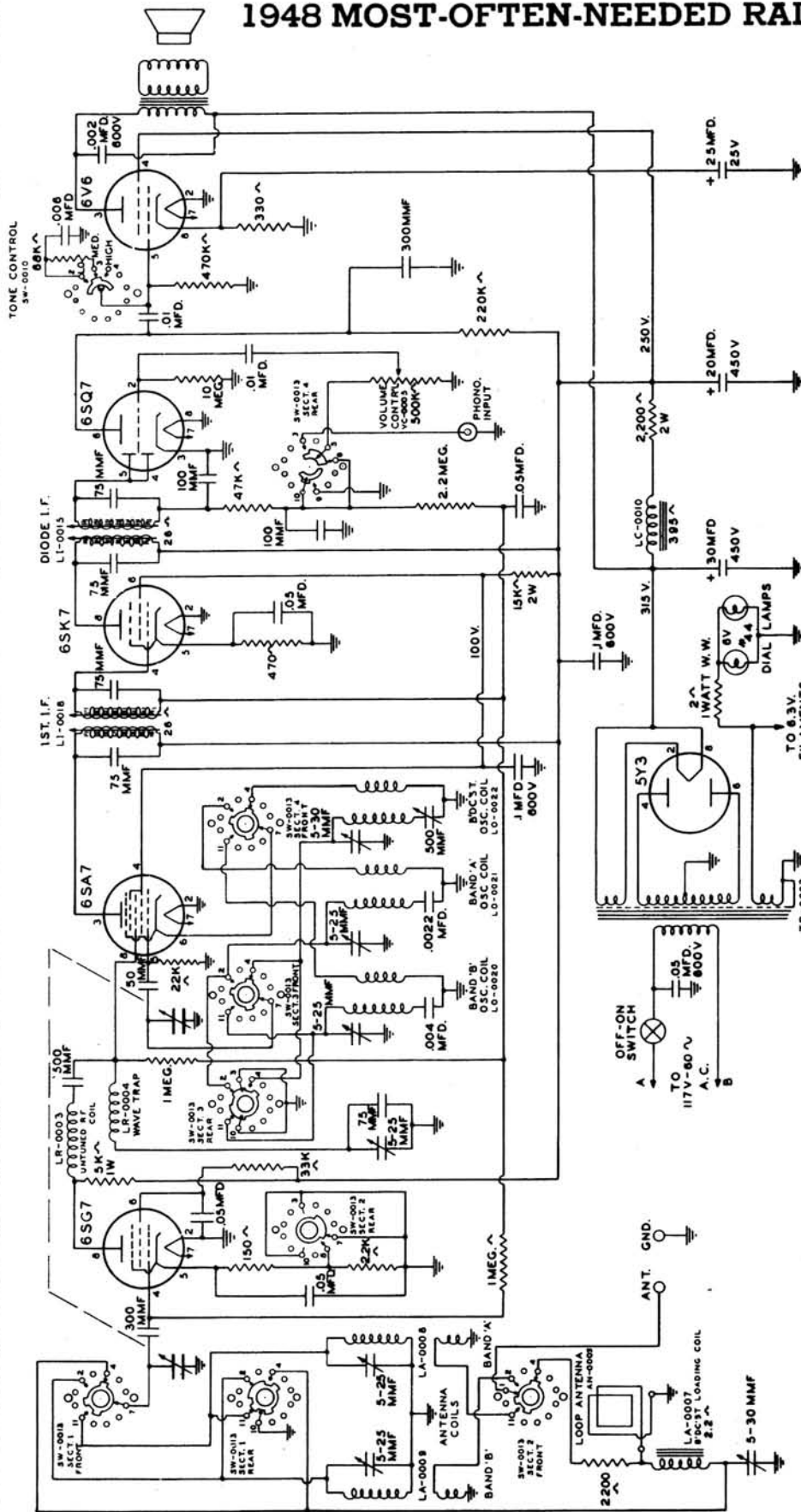

- NOTES -**
1. BAND SWITCH, SW-0013, SHOWN IN BROADCAST POSITION
 2. FRONT AND REAR SECTIONS OF SWITCH SHOWN VIEWED FROM KNOB END.
 3. TONE CONTROL SWITCH, SW-0010, SHOWN VIEWED FROM KNOB END.
 4. BAND SWITCH POSITIONS:
 1. PHONOGRAPH.
 2. RADIO SHORT WAVE BAND.
 3. RADIO SHORT WAVE BAND 'A'.
 4. RADIO SHORT WAVE BAND 'B'.
 5. RADIO SHORT WAVE BAND 'C'.
 5. PRIMARY LEADS 'A' AND 'B' CONNECT TO 'A' AND 'B' ON PRIMARY CIRCUIT FOR UNIVERSAL 110-220 VOLT OPERATION.

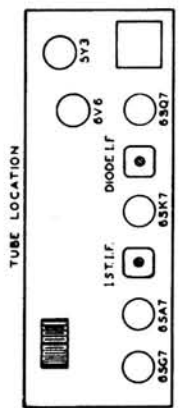
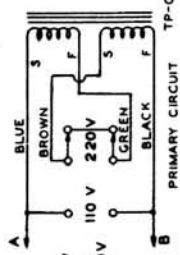

Model 906-S
See Page 76 for Alignment

HOWARD RADIO COMPANY

75

MANUAL OF 1948 MOST-OFTEN-NEEDED RADIO DIAGRAMS

Howard Radio Company. Model 906-S. See page 75 for Schematic.

Voltage reading taken from ground with voltage at line set at 117 volts A.C. These readings were taken with a vacuum tube voltmeter of the VoltOhmyst Junior type.

TUBE	FUNCTION	CATH.	*	SC.	*	PLATE	*	B	*
6SG7	R.F	7.2	5 3	200.	6	210.	8		
6SA7	Convertor			-10. 85.	5 4	225.	3		
6SK7	1st. I.F.	3.	5	90.	6	230.	8		
6SQ7	Det. & 1st. Audio.					110.	6		
6V6	Output.	13.	8	230.	4	280.	3		
5Y3	Rectifier							290.	8

Voltage drop across filter choke 10 volts

* Socket Terminal Number.

	DUMMY ANTENNA	SIG. GEN. CONNECTION	GEN. FREQ.	BAND POSITION	DIAL SETTING	ORDER OF TRIMMER ADJUSTMENTS	TRIMMER FUNCTION	SEE NOTE	
1	.05 Mfd.	Grid of 6SA7	455 KC	BC	Off Station	①②③④	I.F. Peak to Maximum	A	
2	.05 Mfd.	Ant.	455 KC	BC	Off Station	⑤	Null	B	
3	400 Ohm. Line	"A" Ant. Post	600 KC	BC	600 KC	⑦	Maximum	C	
4	400 Ohm. Line	"A" Ant. Post	1400 KC	BC	1400 KC	⑥⑧	BC Osc. and R.F.	D	
5	Repeat operations 3 and 4								E
6	400 Ohm. Line	"A" Ant. Post	6 MC	A	6 MC	⑨⑩	Maximum	F	
7	400 Ohm. Line	"A" Ant. Post	20 MC	B	20 MC	⑪⑫	Maximum	G	
8	Accurately set signal generator at one MC and check through both short wave dials, harmonics to be one MC apart.								

NOTE A. The I.F. adjustments are iron core slug tuning and it should not be necessary to move them very far in either direction from the factory setting, since they are of a very stable nature.

NOTE B. Important. Connect the signal generator to the antenna screw on the outside of the radio chassis and keep the metal of the chassis between the generator lead and the wave trap coil. Use your signal generator to the desired turned up powerful position and adjust the wave trap trimmer to null.

NOTE C. Padding condenser adjustment for calibration at low frequency end of broadcast band.

NOTE D. Set dial at 1400 KC. Adjust oscillator and R.F. trimmer for maximum sensitivity.

NOTE E. Check broadcast stations across dial for accuracy.

NOTE F. True Signal at 6. Image at 5.

NOTE G. True signal at 20. Image at 19.

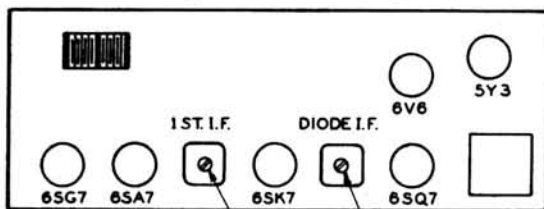

TOP VIEW

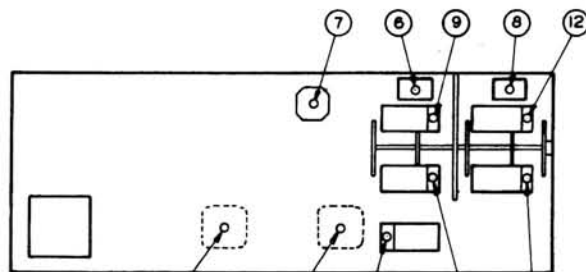

BOTTOM VIEW

MANUAL OF 1948 MOST-OFTEN-NEEDED RADIO DIAGRAMS

HOWARD RADIO COMPANY

Model 909-M
Continued on page 78.

	DUMMY ANTENNA	SIG. GEN. CONNECTION	GEN. FREQ.	BAND POSITION	DIAL SETTING	ORDER OF TRIMMER ADJUSTMENTS	TRIMMER FUNCTION	SEE NOTE
1	.05 Mfd.	Grid of 6SA7	455 KC	BC	Low end of BC	1,2,3,4	I.F.	A
2	.05 Mfd.	Pin #4 6SK7	1400 KC	BC	1400 KC	5,6	BC Osc. and R.F.	
3	Note B	Note B	1400 KC	BC	1400 KC	7	Loop	B
4	400 Ohm. Line	Antenna on loop	11.9 MC	SW	11.9 MC	8,9,10	SW	C
5	Accurately set signal generator at one MC and check through short wave dial, harmonics to be one MC apart.							

NOTE A. The I.F. adjustments are iron core slug tuning and it should not be necessary to move them very far in either direction from the factory setting, since they are of a very stable nature.

NOTE B. Inductively couple signal generator to loop by wrapping one or two turns of wire around outside wire of loop and fasten one end to the high side of the signal generator.

NOTE C. In adjusting trimmer #8, be sure the image of the I.F. is at approximately 11.MC.

CAUTION: Do not knife gang unless absolutely necessary, and then with extreme care.

RECOMMENDED DUMMY ANTENNA. Although the values as shown in above table for antenna load may be satisfactory, we urgently recommend the circuit as shown at the right to properly take care of the various frequencies to accomplish the correct alignment.

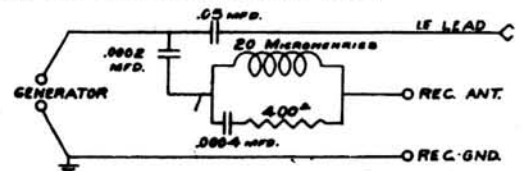

NOTES -

1. RESISTORS ARE 1/4 W., 20% UNLESS OTHERWISE NOTED. "K" = 1000 OHMS
2. 6.3V FILAMENT STRING IS ENTIRELY UNGROUNDED ON POWER PACK CHASSIS. ONE SIDE IS GROUNDED ON R.F. CHASSIS ONLY.
3. VOLTAGES SHOWN ARE MEASURED TO GROUND WITH ELECTRONIC VOLT-OHM METER UNDER NO SIGNAL CONDITIONS, AND ARE SUBJECT TO ±20% NORMAL VARIATION.

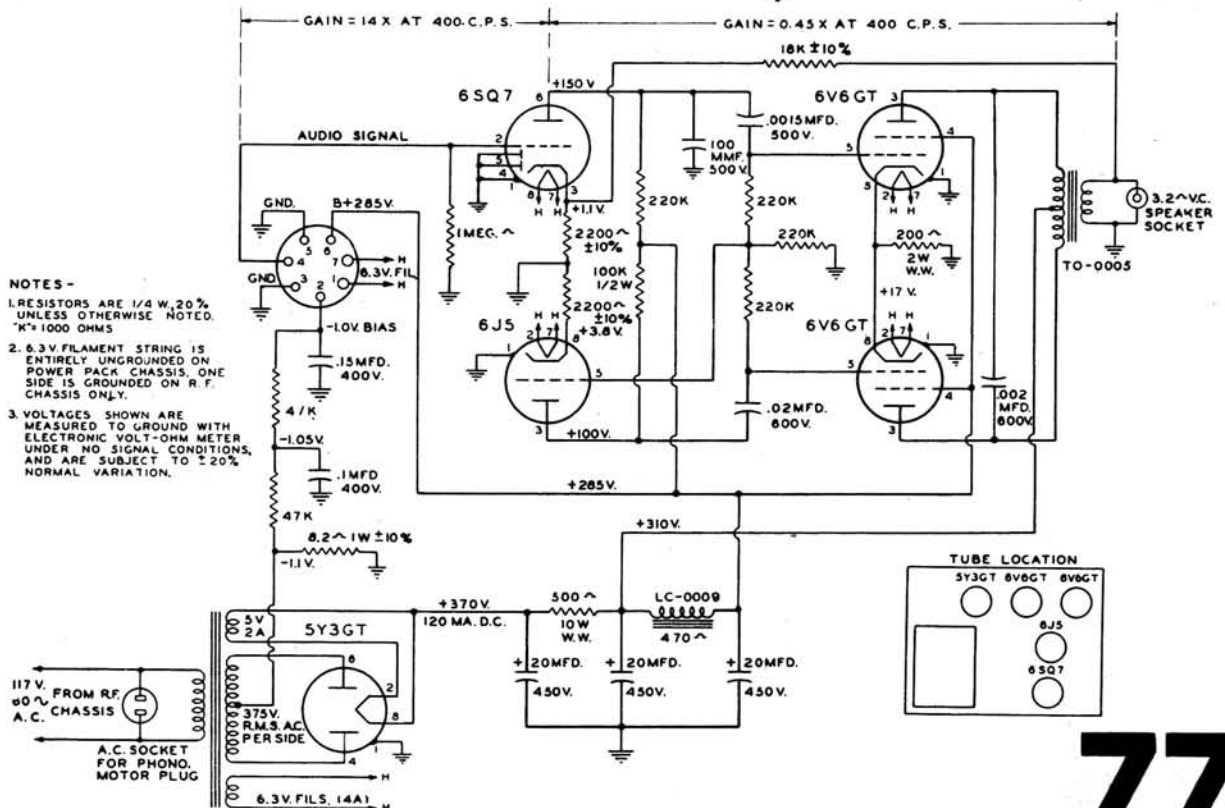

MANUAL OF 1948 MOST-OFTEN-NEEDED RADIO DIAGRAMS

HOWARD RADIO COMPANY

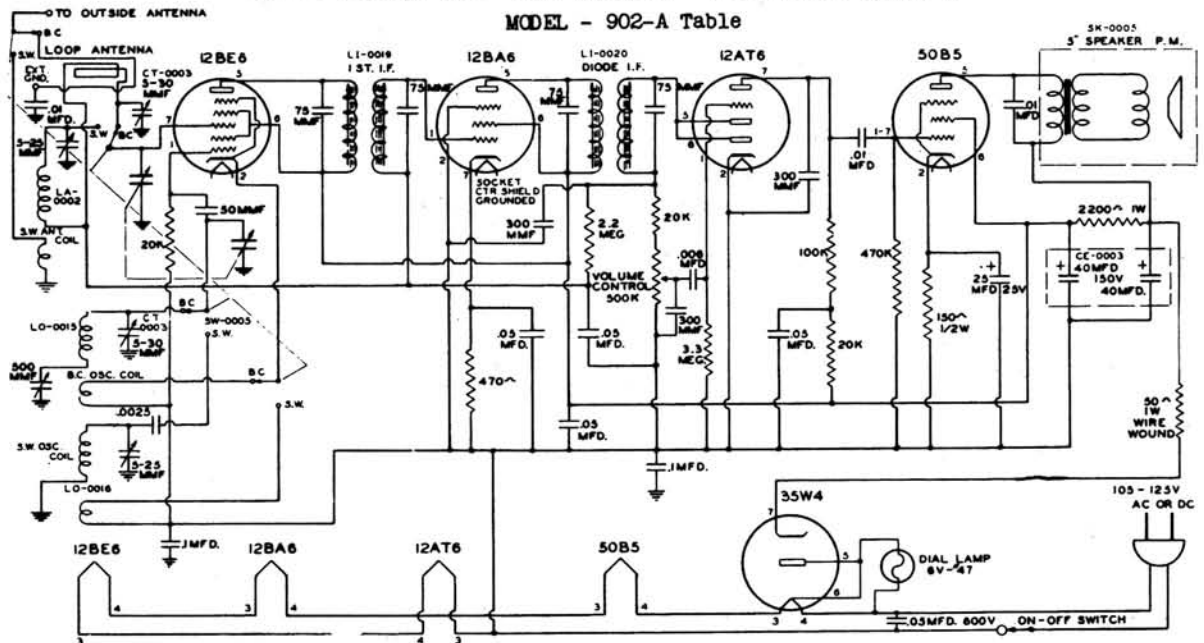

VOLTAGE AND ALIGNMENT CHARTS

TUBE	FUNCTION	CATH.	SCR. GRID	PLATE	TUBE	FUNCTION	CATH.	SCR. GRID	PLATE
12BE6	Mixer	0	79	79	12AT6	Det.	0	--	56
12BA6	I.F. Det.	2	79	79	50B5	Output.	4.6	79	110

	DUMMY ANTENNA	SIG. GEN. CONNECTION	GEN. FREQ.	BAND POSITION	DIAL SETTING	ORDER OF TRIMMER ADJUSTMENTS	TRIMMER FUNCTION
1	.05 MFD.	Grid of 12BE6	445 KC	BC	Off Station	1 2 3 4	I.F. Peak to Max. Output
2	400 Ohm Resistor	Ant.	1400 KC	BC	1400 KC	5 7	BC Osc. and R.F.
3	400 Ohm Resistor	Ant.	600 KC	BC	600 KC	6	BC Osc., Pad.
4	400 Ohm Resistor	Ant.	16 MC	SW	16 MC	9, 8	SW Osc. and R.F.

TRIMMER LOCATIONS

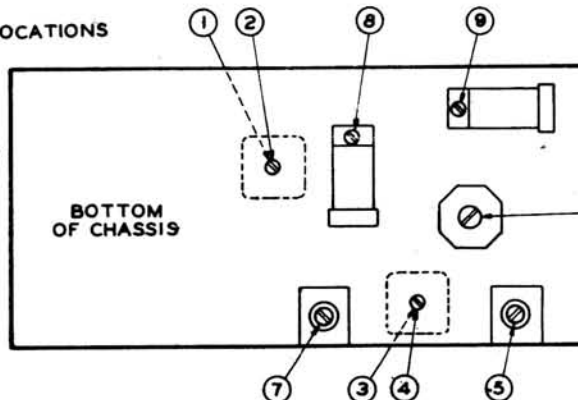

For Model 906-C
See Page 63 in
Volume 7, 1947
Diagram Manual.

BROADCAST BAND 535-1850KC
SHORT WAVE BAND 8-18MEGACYCLES
(IF. 455KC)

NOTE -
ALL COND. ARE 400V
UNLESS OTHERWISE NOTED.
ALL RESISTORS ARE 1/4W
UNLESS OTHERWISE NOTED.
BAND SWITCH, SW-0005, SHOWN IN BROADCAST POSITION

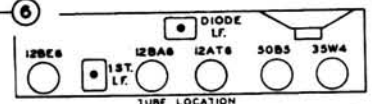

79

MANUAL OF 1948 MOST-OFTEN-NEEDED RADIO DIAGRAMS

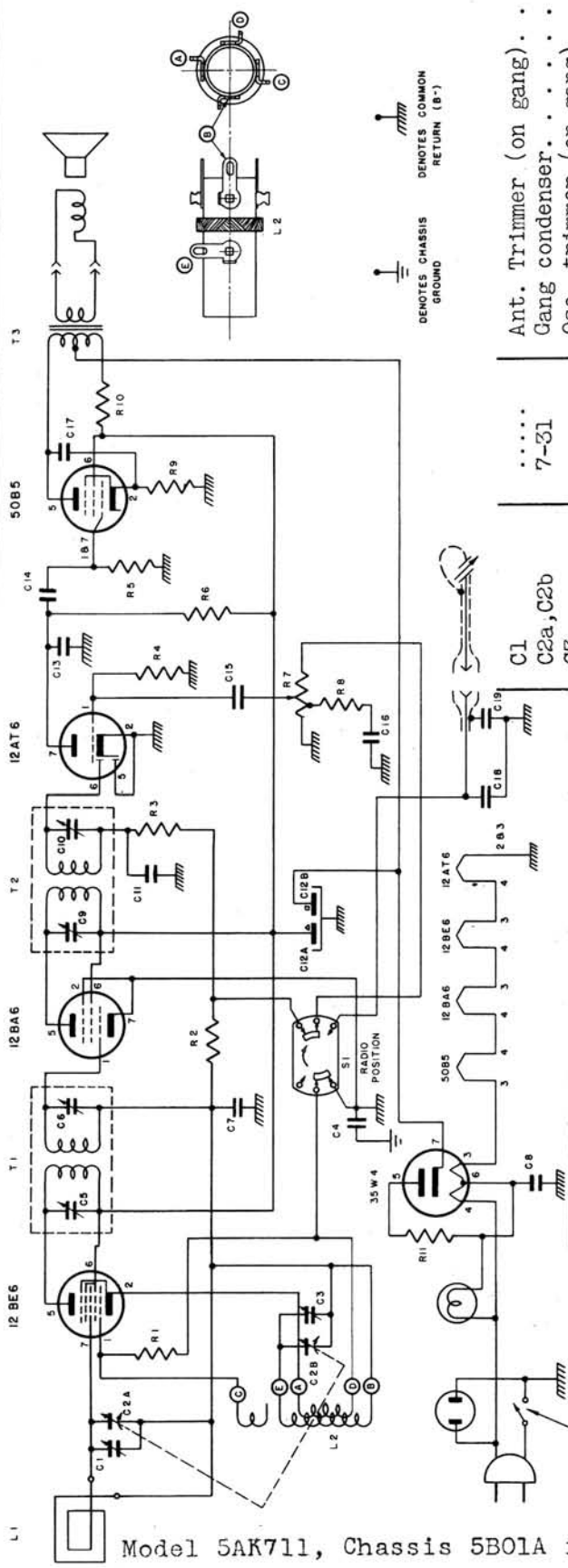

- Ant. Trimmer (on gang)
- Gang condenser
- Osc. trimmer (on gang)
- 0.1 mfd. 200V
- On 1st I.F. Transformer
- .05 mfd. 200V
- On 2nd I.F. Transformer
- 220 mmf. 500V mica
- 20 mfd. 40 mfd. 150V Elec
- .01 mfd. 200V
- .002 mfd. 200V
- .04 mfd. 400V
- 22K ohm, 1/4 watt
- 3.3 megohm, 1/4 watt
- 10 megohm, 1/4 watt
- 470K ohm, 1/4 watt
- 330K ohm, 1/2 watt
- 500K ohm volume control
- 18K ohm, 1/4 watt
- 150 ohm, 1 watt
- 1200 ohm, 1 watt
- 27 ohm, 1/4 watt
- Loop Assembly
- Oscillator coil

- 7-31
- 5-39
- 5-40
- 6-151
- 19-25
- 5-57
- 5-52
- 5-58
- 01-143
- 01-234
- 01-255
- 01-199
- 02-192
- 13-28
- 01-139
- 03-52
- 03-90
- 01-20
- S-1354
- S-1374

TUBE	ELEMENT	PIN	VOLTS
12BE6 Converter	Plate	5	88
	Screen Grid	6	88
	Grid	7	0.6
12BA6 I.F. Amp.	Plate	5	88
	Screen Grid	6	88
	Grid	1	-0.6
12AT6 2nd Det., AVC	Plate	7	38
	Grid	1	-0.6
50B5 Output	Plate	5	107
	Screen Grid	6	88
	Cathode	2	4.9
35W4 Rectifier	Grid	1 & 7	0
	Plate	5	117AC
	Cathode	7	115

NOTE: All voltages measured with a vacuum tube voltmeter to B---. A full line voltage of 117 V.A.C., volume control at minimum

Majestic

MODELS 5AK731-5AK780
CHASSIS 5B05A

See page 82 for alignment

Model 5AK711, Chassis 5B01A is similar, but less phono.

MANUAL OF 1948 MOST-OFTEN-NEEDED RADIO DIAGRAMS

Majestic

Models 5AK731, 5AK780

Chassis 5B05A

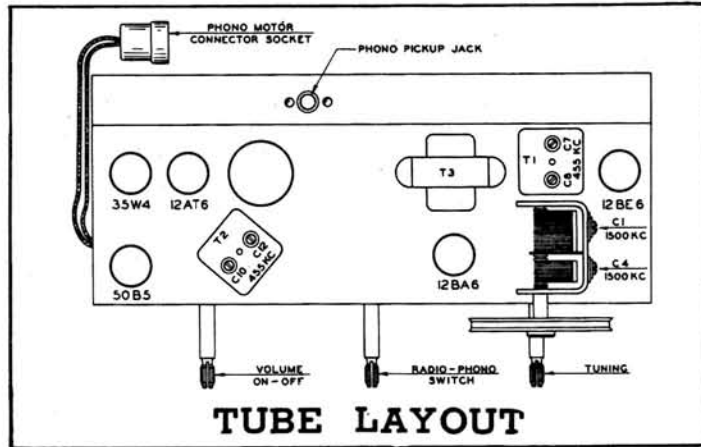

ALIGNMENT

Before aligning, set the dial pointer as follows: Close the tuning gang condenser (plates fully closed). Set the dial pointer so that it is in line with the last mark at the low frequency end of the dial scale.

While aligning this receiver, turn the volume control full on, and keep the signal generator output as low as possible to prevent AVC action and false readings.

OPERATION	CONNECT OSC. TO	DUMMY ANTENNA	INPUT SIGNAL FREQUENCY	SET DIAL TO	ADJ. TRIMMERS	PURPOSE
1	Pin 7 on converter tube 12BE6 socket	.05mfd	455KC Modulated	600KC	C5, C6, C9 and C10	Align I.F. channel for maximum output
2	2 turns loosely cpld. to loop ant.	-----	1500KC Modulated	1500KC	C3	Set oscillator to dial scale
3	2 turns loosely cpld. to loop ant.	-----	1500KC Modulated	1500KC	C1	Align ant. for maximum output

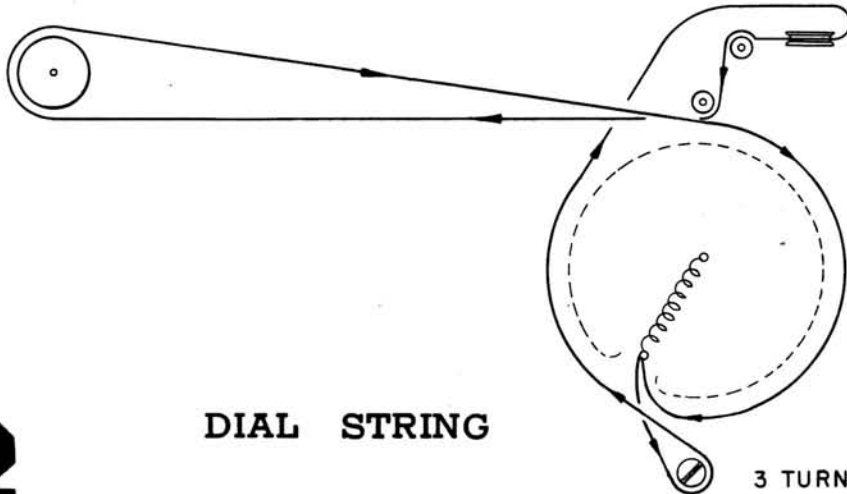

DIAL STRING

MANUAL OF 1948 MOST-OFTEN-NEEDED RADIO DIAGRAMS

MODEL 8S473
CHASSIS 4810

Majestic

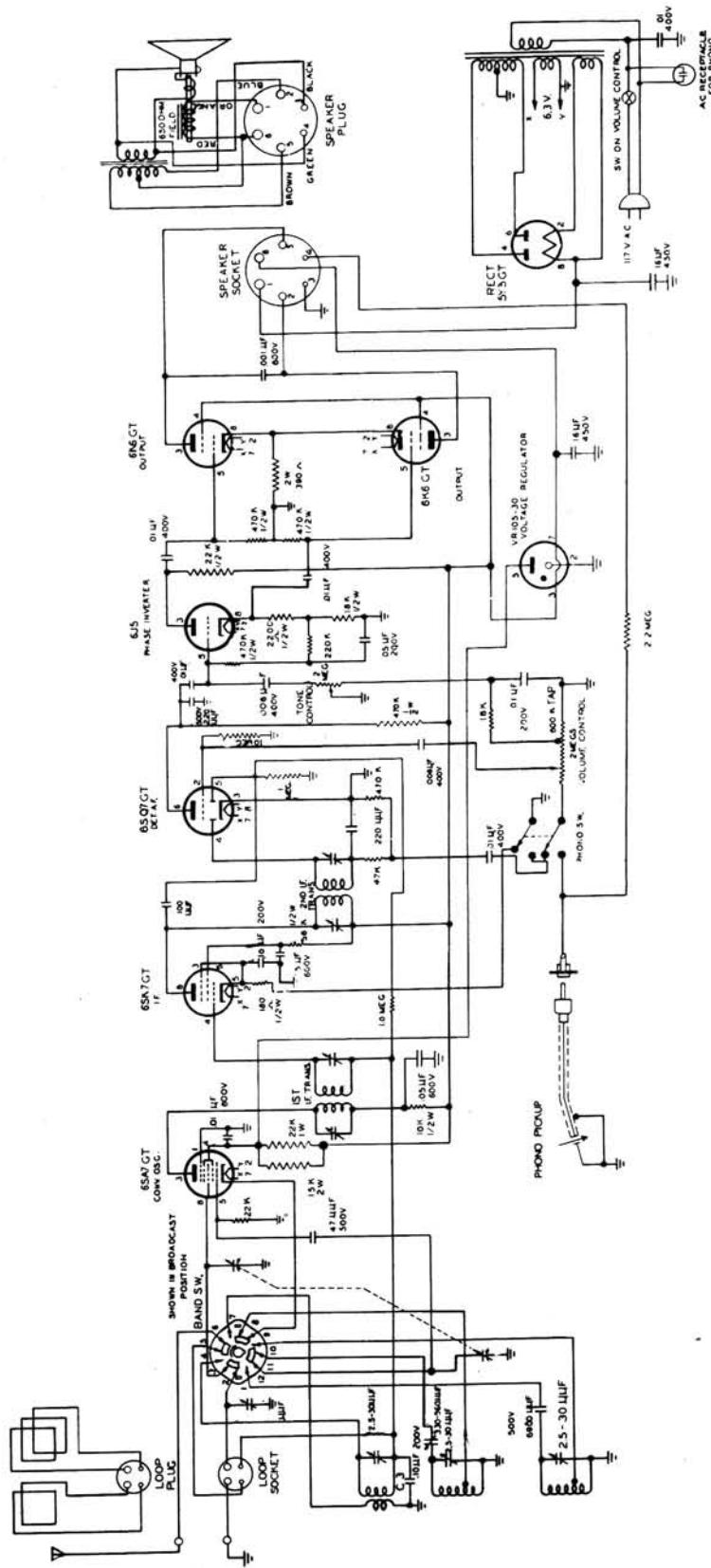

I.F. 455 KC.

SCHEMATIC DIAGRAM - CHASSIS 4810
(LATE PRODUCTION - SERIAL NUMBERS HIGHER THAN A235000)

MANUAL OF 1948 MOST-OFTEN-NEEDED RADIO DIAGRAMS

Majestic

MODEL 7P420
CHASSIS 4705

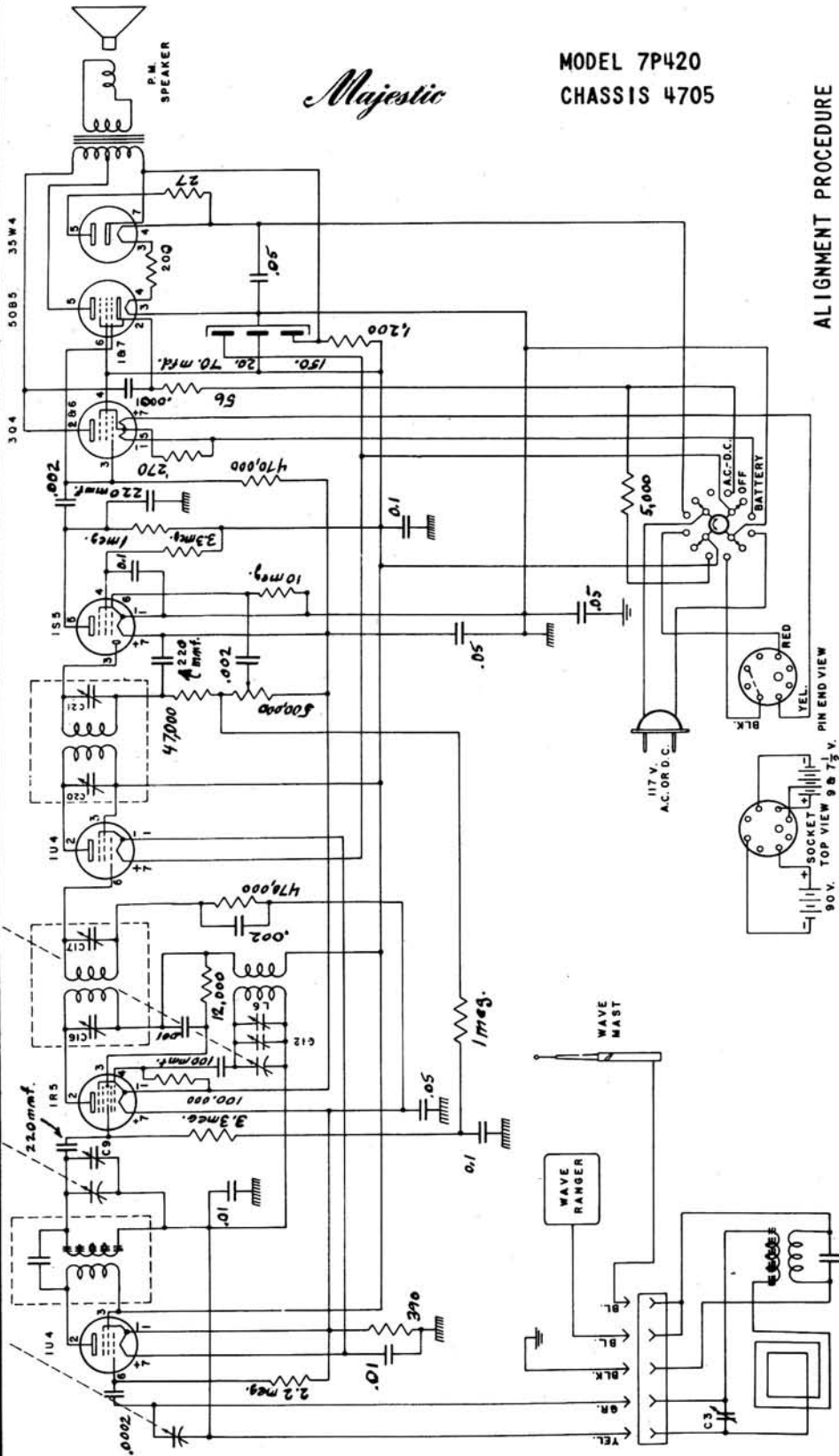

ALIGNMENT PROCEDURE

STEP	DUMMY ANTENNA	TEST OSCILLATOR CONNECTION	TEST OSCILLATOR FREQUENCY	RECEIVER DIAL	ADJUST FOR MAXIMUM
1	.01 MFD.	1R5 GRID	455 KC	ANY QUIET SPOT	C16, C17 C20, C21
2	LOOP		1500 KC	150	C12, C9, C3

NOTE: ALL RESISTORS TO BE 1/2 WATT, UNLESS OTHERWISE SPECIFIED.

⏏ DENOTES COMMON RETURN (B-)

⏏ DENOTES CHASSIS

MANUAL OF 1948 MOST-OFTEN-NEEDED RADIO DIAGRAMS

MASCO PORTABLE PHONOGRAPH AMPLIFIER

MARK SIMPSON MANUFACTURING CO., INC.

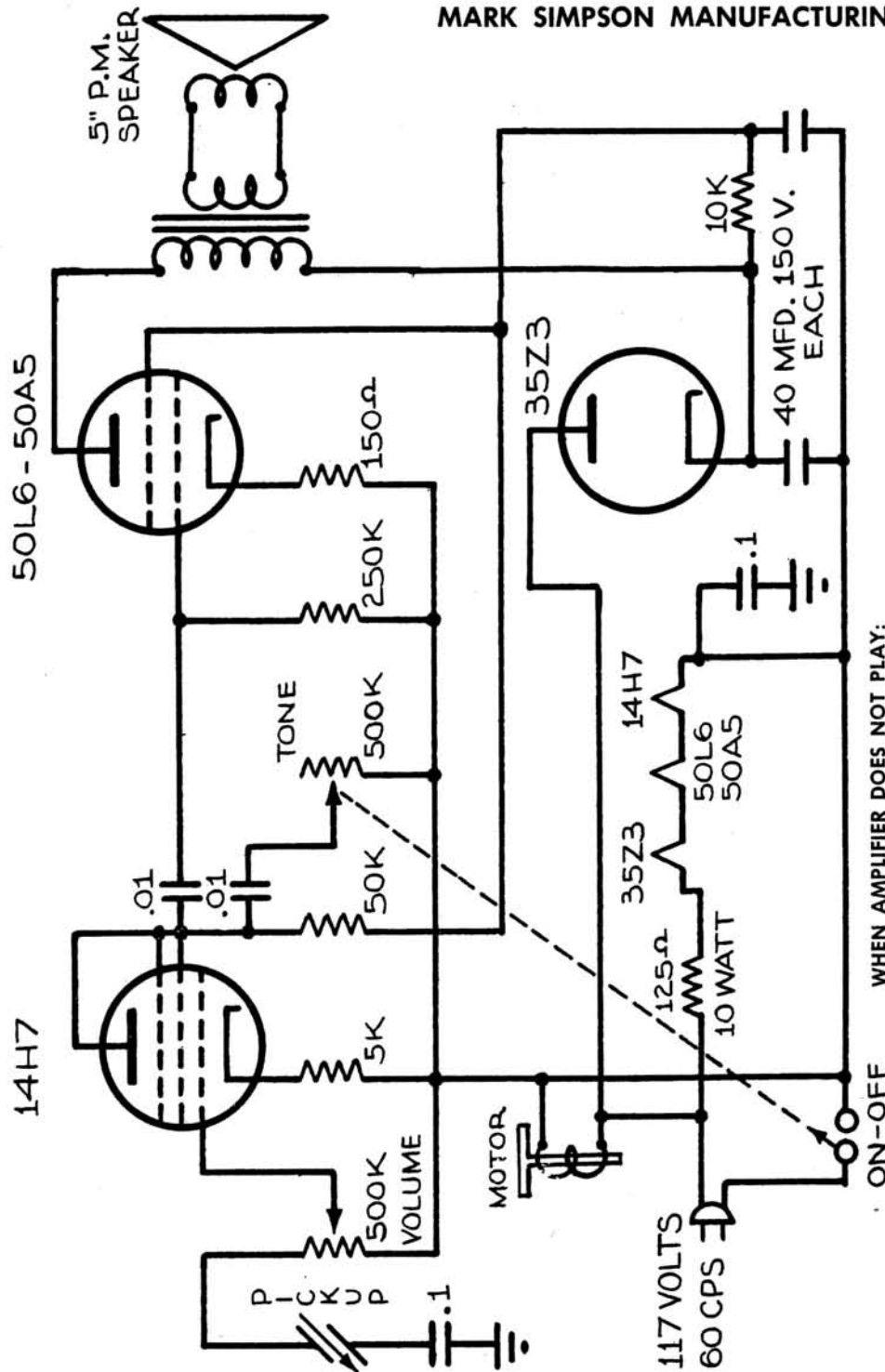

WHEN AMPLIFIER DOES NOT PLAY:

1. SEE THAT ALL TUBES ARE INSERTED IN CORRECT SOCKETS.
2. CHECK ALL CONNECTIONS.
3. CHECK FILTER CONDENSER FOR OPEN OR SHORT.
4. CHECK LINE CORD FOR OPEN CIRCUIT.
5. TEST 125 OHM 10 WATT WIRE WOUND RESISTOR FOR OPEN CIRCUIT.

NOTE: WHEN 35A5 IS USED, 125 OHM 10 WATT RESISTOR IS REPLACED BY 200 OHM 10 WATT RESISTOR.
WHEN ASTATIC RL-267 PICKUP IS USED A .1 MFD. CONDENSER IS CONNECTED ACROSS THE 14H7 CATHODE RESISTOR.

MANUAL OF 1948 MOST-OFTEN-NEEDED RADIO DIAGRAMS

JOHN MECK INDUSTRIES, Inc., CHASSIS RC-5C5-P or PM-5C5-P

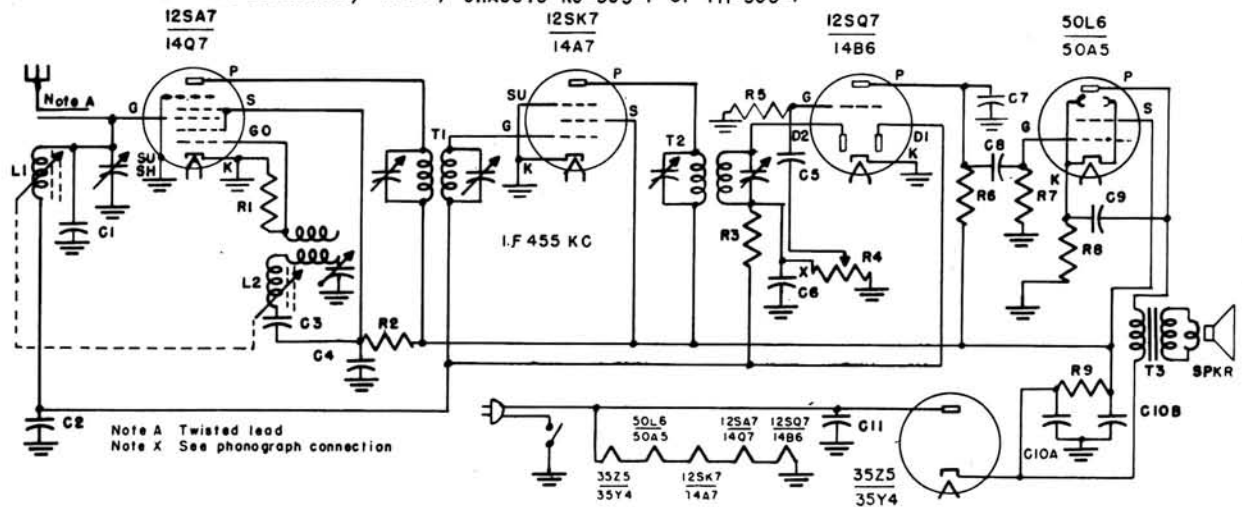

Circuit Symbol	Part Number	Description	Circuit Symbol	Part Number	Description
C1	CM-15250	Condenser-Mica, 25 mfd., 500 volt	R8	RC-31500	Resistor-Carbon, 150 ohms, 1/2 watt
C2, C9, C11	CP-145031	Condenser-Paper, 0.05 mfd., 400 volt	R9	RC-31001	Resistor-Carbon, 1000 ohms, 1/2 watt
C3, C5, C8	CP-14103	Condenser-Paper, 0.01 mfd., 400 volt	SPKR	SR-10000	Speaker-P.H. 4" round less T3
C4	CM-15301	Condenser-Mica, 300 mfd., 500 volt	T1	TS-10000	Transformer-1st. I.F.
C6, C7	CM-15251	Condenser-Mica, 250 mfd., 500 volt	T2	TS-10001	Transformer-2nd. I.F.
C10A, C10B	CL-10001	Condenser-Elect., 20/20 mfd., 150 volt	T3	TO-10000	Transformer-Output
L1, L2	YP-10000	Tuner-Permeability, assembly	PHONOGRAPH MODEL		
R1	RC-32002	Resistor-Carbon, 20,000 ohms, 1/2 watt	MI	PRS-10000	Motor-Phono, with turntable
R2	RC-34001	Resistor-Carbon, 4000 ohms, 1/2 watt	PI	PA-10000	Pickup-Crystal
R3	RC-32004	Resistor-Carbon, 2 megohms, 1/2 watt	R10	RC-31004	Resistor-Carbon, 1 megohm, 1/2 watt
R4	YC-10105	Control-Volume, 1 megohm with switch	R11	RC-37503	Resistor-Carbon, 750,000 ohms, 1/2 watt
R5	RC-31005	Resistor-Carbon, 10 megohms, 1/2 watt	SI	VS-10000	Switch-Radio, phono
R6	RC-32502	Resistor-Carbon, 250,000 ohms, 1/2 watt			
R7	RC-35003	Resistor-Carbon, 500,000 ohms, 1/2 watt			

VOLTAGE TABLE - Use high resistance voltmeter of 1000 ohms per volt

Type tube	1	2	3	4	5	6	7	8
12SA7	0	24AC	78	78	-7 to -12	0	12AC	-.65 to -1.2
12SK7	0	36AC	0	-8 to -1.2	0	78	24AC	78
12SQ7	0	-9 to -1.2	0	0	-8 to -1.2	55	12AC	0
50L6	0	--	95	78	0	--	36AC	4 to 5
35Z5	-	82	--	78	115 AC	100	115 AC	110
14Q7	24AC	78	78	-7 to -12	0	-.65 to -1.2	0	12AC
14A7	36AC	78	78	0	0	-.8 to -1.2	0	24AC
14B6	0	55	-.9 to -1.2	0	0	0	0	12AC
50A5	82AC	95	78	--	--	0	4 to 5	36AC
35Y4	115AC	115AC	78	--	100	--	110	82AC

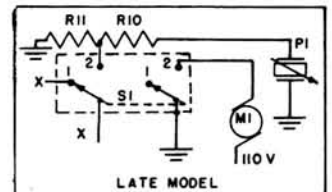
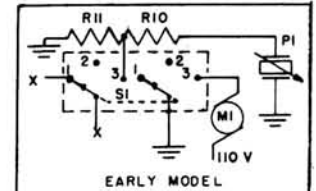

PHONOGRAPH CONNECTION

I.F. ALIGNMENT: The step-by-step routine given below should be carefully followed:

1. The signal generator must be set at 455 kilocycles.
2. Connect the output meter so that the output can be determined.
3. Connect the high side of the signal generator output to the antenna lead of the tuner, the white wire. The low side of the signal generator output lead is connected to the chassis through a 0.01 mfd. condenser.
4. Turn the volume control on full and turn the dial drive shaft so that the slugs of the tuner unit are all the way out against the stop.
5. Adjust the four I.F. trimmers, tuning each carefully to get the maximum deflection of the output meter. Reduce the signal generator output if the output meter goes off scale.
6. Repeat all four adjustments since the adjustment of each I.F. trimmer may effect the others to a certain extent.

OSCILLATOR and R.F. ALIGNMENT:

1. Connect the high side of the signal generator output to the insulation covering of the antenna wire and not the wire itself.
2. Set the signal generator to 1680 kilocycles with the slugs of the tuner all the way out against the stop. Adjust the oscillator trimmer, right hand trimmer screw, for maximum reading on the output meter.
3. Set the signal generator at 1120 kilocycles and turn the dial drive shaft until the 1120 kilocycle note is heard. Adjust the R.F. trimmer, left hand trimmer, for maximum reading on the output meter. Set the dial pointer on 1120 kilocycles on the dial scale. By aligning the R.F. section at 1120 kilocycles the overall alignment will be very good.

MANUAL OF 1948 MOST-OFTEN-NEEDED RADIO DIAGRAMS

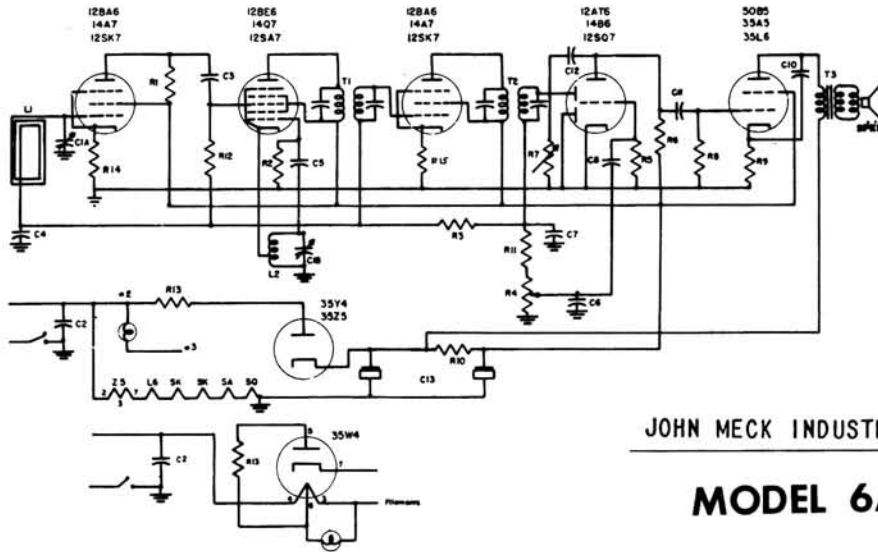

JOHN MECK INDUSTRIES, Inc.

MODEL 6A7

SYMBOL	PART NO.	DESCRIPTION	SYMBOL	PART NO.	DESCRIPTION
C1	CV-10009	Condenser, Variable with Pulley.	R4	VC-11105	Control, Volume 1 megohm with switch.
C2	CP-14503	Condenser, Paper .05 Mfd. 400 volts.	R5	RC-31005	Resistor, Carbon 10 megohm 1/2 watt.
C3	CH-15250	Condenser, Mica 25 mmf. 500 volts.	R6	RC-32203	Resistor, Carbon 220,000 ohm 1/2 watt.
C4	CP-12503	Condenser, Paper .05 Mfd. 200 volts.	R7	VC-13105	Control, Tone 1 megohm.
C5	CH-15500	Condenser, Mica 50 mmf. 500 volts.	R8, R12	RC-34703	Resistor, Carbon 470,000 ohm 1/2 watt.
C6-C7	CH-15251	Condenser, Mica 250 mmf. 500 volts.	R9, R14	RC-31500	Resistor, Carbon 150 ohm 1/2 watt.
C8, C11	CP-14103	Condenser, Paper .01 mfd. 400 volts.	R10	RC-41001	Resistor, Carbon 1000 ohm 1 watt.
C10	CP-14203	Condenser, Paper .02 mfd. 400 volts.	R11	RC-31003	Resistor, Carbon 100,000 ohm 1/2 watt.
C12	CP-14302	Condenser, Paper .003 mfd. 400 volts.	R13	RC-30220	Resistor, Carbon 22 ohm 1/2 watt.
C13	CL-10007	Condenser, Electrol. 50/30 mfd. 150	R15	RC-33300	Resistor, Carbon 330 ohm 1/2 watt.
L1	AL-10010	Loop Antenna.	SPKR	SO-10002	Speaker, Oval 4 x 6.
L2	TRC-10000D	Coil, Oscillator	T1	TS-10000	Transformer, I. F. Input.
R1	RC-34701	Resistor, Carbon 4700 ohm 1/2 watt.	T2	TS-10001	Transformer, I. F. Output.
R2	RC-32202	Resistor, Carbon 22000 ohm 1/2 watt.	T3	TO-10000	Transformer, Output.
R3	RC-32204	Resistor, Carbon 2.2 megohm 1/2 watt.			

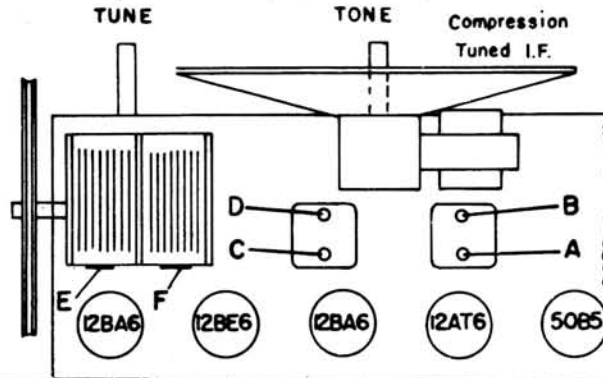
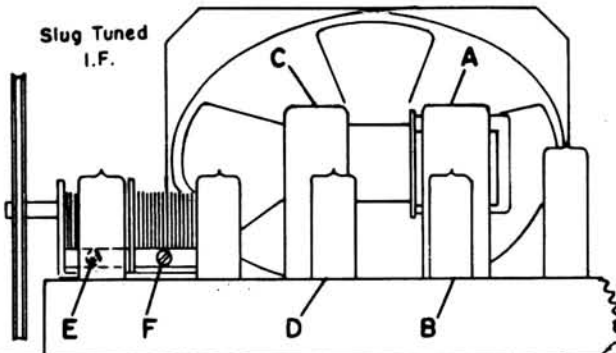

Signal Generator Coupling	Signal Generator Frequency	Gang Condenser Position	Output Meter	Adjust	Remarks
High side of Mixer tube Grid (12BE6)	455 Kc	Stator Turned out to minimum Capacity position	Across Voice Coil	A, B, C, D	Adjust for maximum output. If isolation transformer is not used, reduce dummy ant. to .001 MFD. to reduce hum modulation.
Loop	1720 Kc	Stator Turned out to minimum Capacity position	Across Voice coil	E	Fashion loop from few turns of wire and radiate signal into set. Adjust for maximum output.
Loop	1500 Kc	Tune gang to resonance	Across Voice coil	F	Fashion loop from few turns of wire and radiate signal into set. Adjust for maximum output.

RADIO DIAGRAMS

WATTAGE IS 1/2 EXCEPT WHERE INDICATED.
TOLERANCE IS ±2.0% UNLESS INDICATED.

CAPACITY IS GIVEN EXCEPT WHERE INDICATED.
0.1 & 100 ARE MFD.
RESISTANCE IS GIVEN IN OHMS
M=MEG OHM
K=1000 OHMS

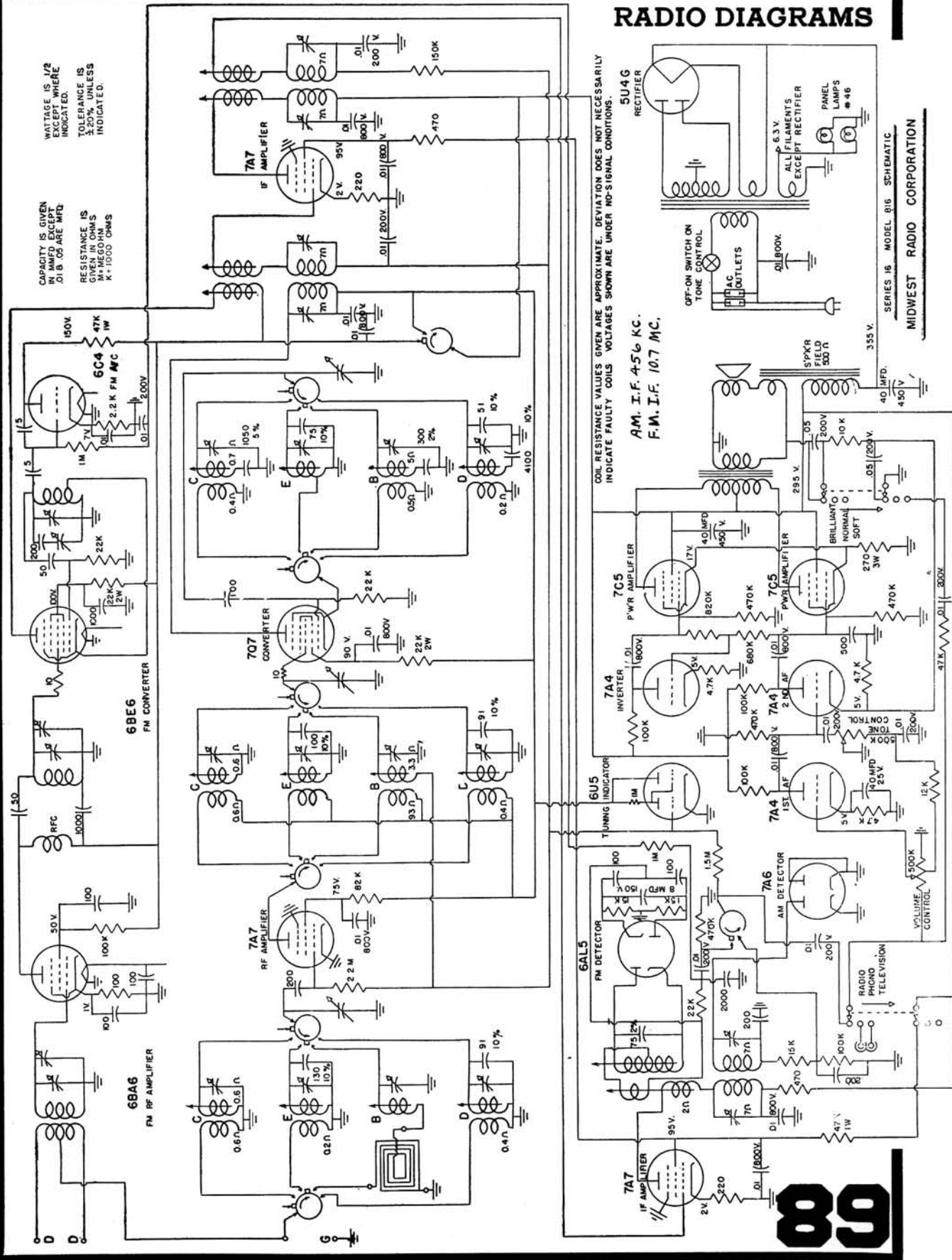

COIL RESISTANCE VALUES GIVEN ARE APPROXIMATE. DEVIATION DOES NOT NECESSARILY INDICATE FAULTY COILS. VOLTAGES SHOWN ARE UNDER NO-SIGNAL CONDITIONS.

AM. I. F. 456 KC.
F. M. I. F. 10.7 MC.

SERIES 16 MODEL B16 SCHEMATIC
MIDWEST RADIO CORPORATION

MANUAL OF 1948 MOST

NEEDED RADIO DIAGRAMS

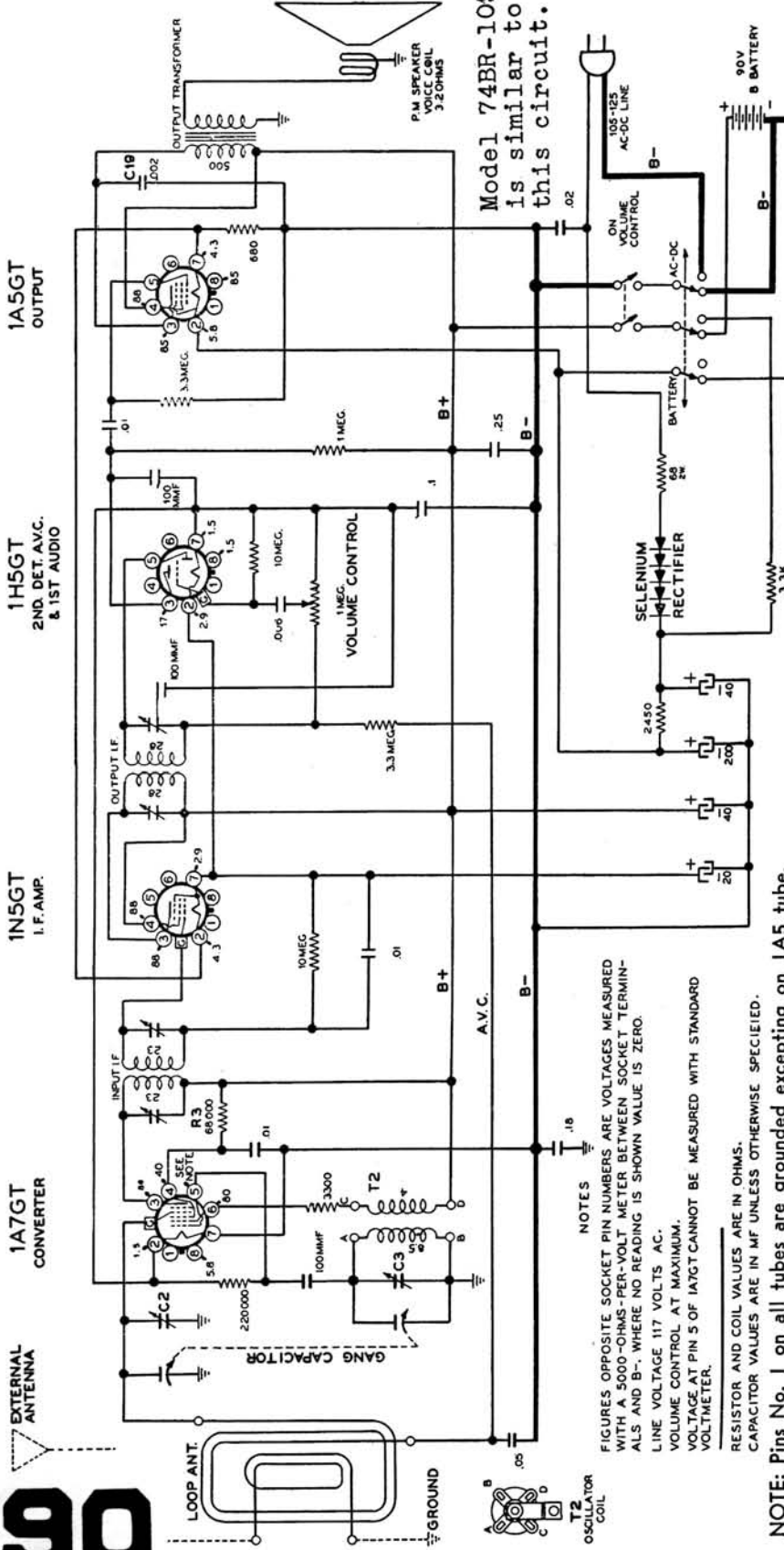

Model 74BR-1055A is similar to this circuit.

WARDS

MODEL 74BR-1053A

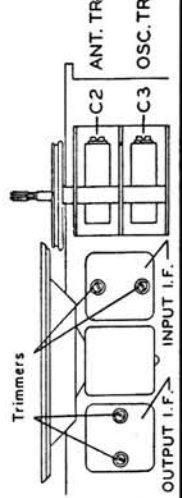

NOTES
 FIGURES OPPOSITE SOCKET PIN NUMBERS ARE VOLTAGES MEASURED WITH A 5000-OHMS-PER-VOLT METER BETWEEN SOCKET TERMINALS AND B-. WHERE NO READING IS SHOWN VALUE IS ZERO.
 LINE VOLTAGE 117 VOLTS AC.
 VOLUME CONTROL AT MAXIMUM.
 VOLTAGE AT PIN 5 OF 1A7GT CANNOT BE MEASURED WITH STANDARD VOLTMETER.
 RESISTOR AND COIL VALUES ARE IN OHMS.
 CAPACITOR VALUES ARE IN MF UNLESS OTHERWISE SPECIFIED.

NOTE: Pins No. 1 on all tubes are grounded excepting on 1A5 tube.

SIGNAL GENERATOR		Ground Connection	DIAL SETTING	ADJUST TRIMMERS TO MAXIMUM OUTPUT in order shown
Frequency	Coupling Capacitor			
455 kc	.1 mf	1A7GT Pin 7	Rotor full open (plates out of mesh)	Input and output trimmers on IF cans
1650 kc	.1 mf	1A7GT Pin 7	Rotor full open (plates out of mesh)	Osc. trimmer on gang (see trimmer view)
1400 kc	Chassis installed in cabinet. Lay lead from generator about 1 ft. from loop. Back cover must be snapped shut. Trimmer is reached thru small hole in end of cabinet. Do not move loop leads after alignment.		Set dial to 1400 kc.	Ant. trimmer on gang (see trimmer view)

*For these adjustments chassis must be removed from cabinet. Insert a 1 megohm resistor between A.V.C. Buss and 1A7GT grid cap. It is assumed loop is disconnected from chassis.

MANUAL OF 1948 MOST-OFTEN-NEEDED RADIO DIAGRAMS

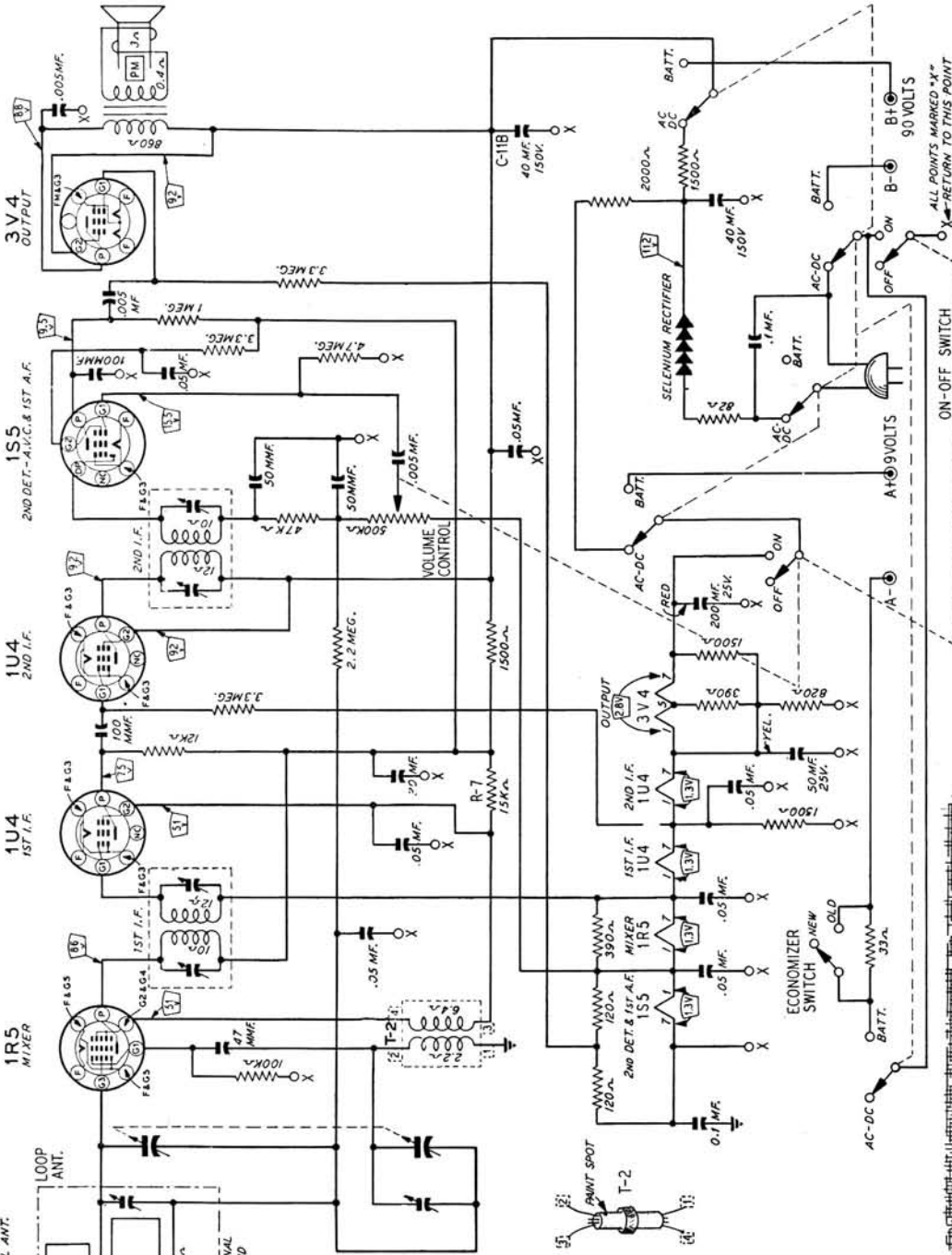

MODEL 74 WG-1054A

WARDS *Airline*

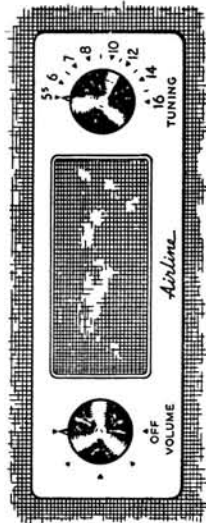

TUBE SOCKET VOLTAGES

The readings were taken with a 1000 ohm-per-volt meter and all plate and screen voltages read on a 500 volt scale. Conditions of measurement are:

- Line voltage.....117 volts AC
- Volume control.....maximum
- Signal input.....none

A variation of ±10% is usually permissible.

Frequency Range.....540-1600 KC
Intermediate Frequency 455 KC

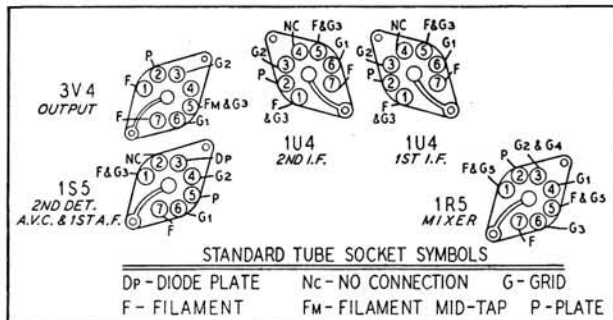

MANUAL OF 1948 MOST-OFTEN-NEEDED RADIO DIAGRAMS

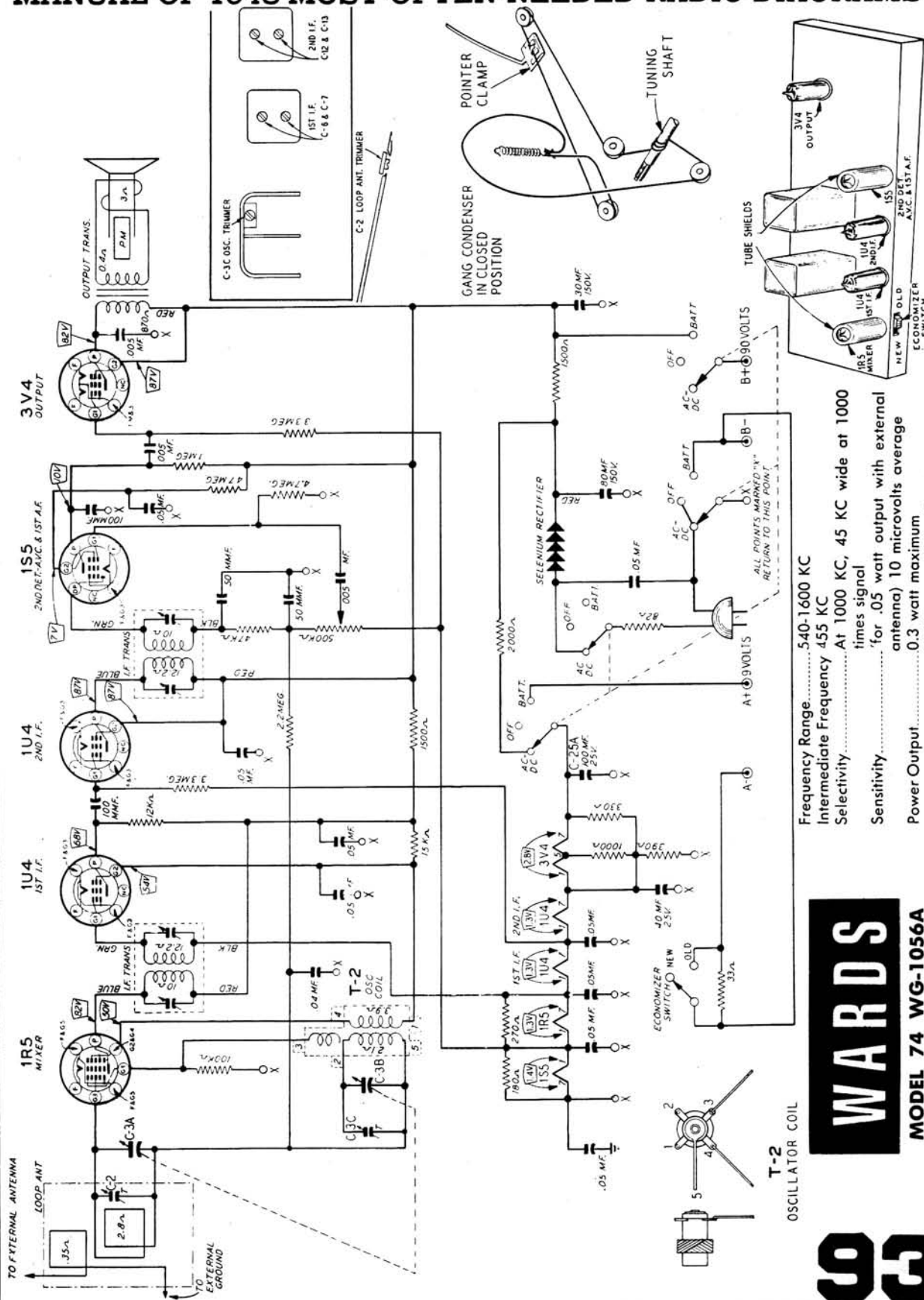

Frequency Range.....540-1600 KC
 Intermediate Frequency 455 KC
 Selectivity.....At 1000 KC, 45 KC wide at 1000 times signal
 Sensitivity.....for .05 watt output with external antenna) 10 microvolts average
 Power Output.....0.3 watt maximum
 0.125 watt 10% distortion

WARDS
 MODEL 74 WG-1056A

93

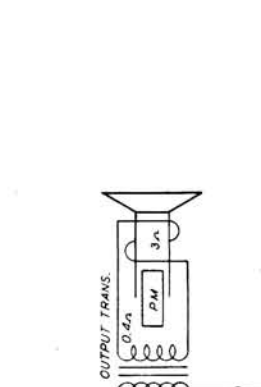
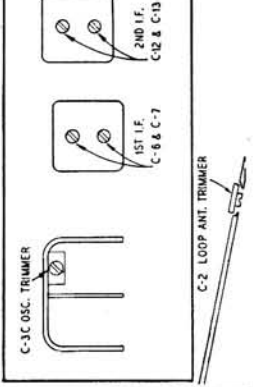
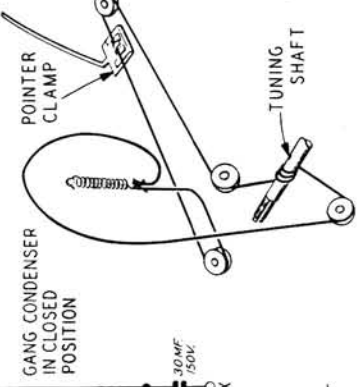
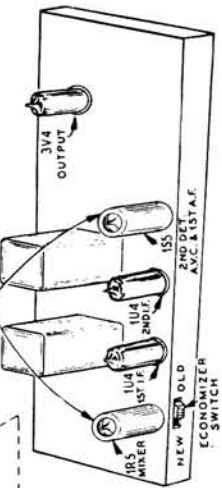
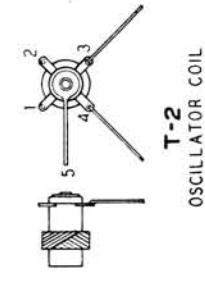

MODELS 74WG-1509A, 74WG-1510A

74WG-1804D, 74WG-1805A are similar.

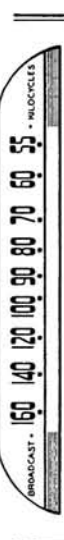

TUBE SOCKET VOLTAGES

Socket voltages are shown on the schematic diagram at the tube socket terminals. All voltages except those for the heater and dial lamp are between the socket terminal and "X" point.

The readings were taken with a 1000 ohm-per-volt meter and all plate and screen voltages read on a 500 volt scale. Conditions of measurement are:

- Line voltage.....117 volts AC
- Volume control.....maximum
- Signal input.....none
- A variation of $\pm 10\%$ is usually permissible.

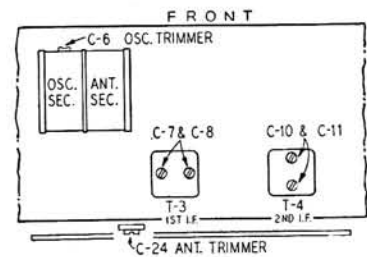

NOTE A:—Index line is on dial light diffuser strip.

Socket voltages are shown on the schematic diagram at the tube socket terminals. All voltages except those for the heater and dial lamp are between the socket terminal and "X" point.

MODELS 74WG-1509A, 74WG-1510A
74WG-1804D, 74WG-1805A are similar.

Frequency Setting	Connection to Receiver	Ground Connection	Coupling Capacitor	DIAL SETTING	ADJUST TRIMMERS TO MAXIMUM OUTPUT IN ORDER SHOWN (See Trimmer Illustration)
455 kc	Control Grid 12SF7—I-F (Prong No. 2)	Point "X" 12SK7—R-F (Prong No. 3)	.1 mf	Turn Rotor to full open	2nd I-F (C10) & (C11)
455 kc	Control Grid 12SA7—1st Det. (Prong No. 8)	Same as above	.1 mf	Turn Rotor to full open	1st I-F (C7) & (C8)
1620 kc	Control Grid 12SA7—1st Det. (Prong No. 8)	Same as above	.1 mf	Turn Rotor to fully open position	Oscillator (C6)
1400 kc	External Antenna Clip on Loop	Chassis	50 mmf	Turn Rotor to 1400 kc Index Line. See Note A	Antenna (C24)

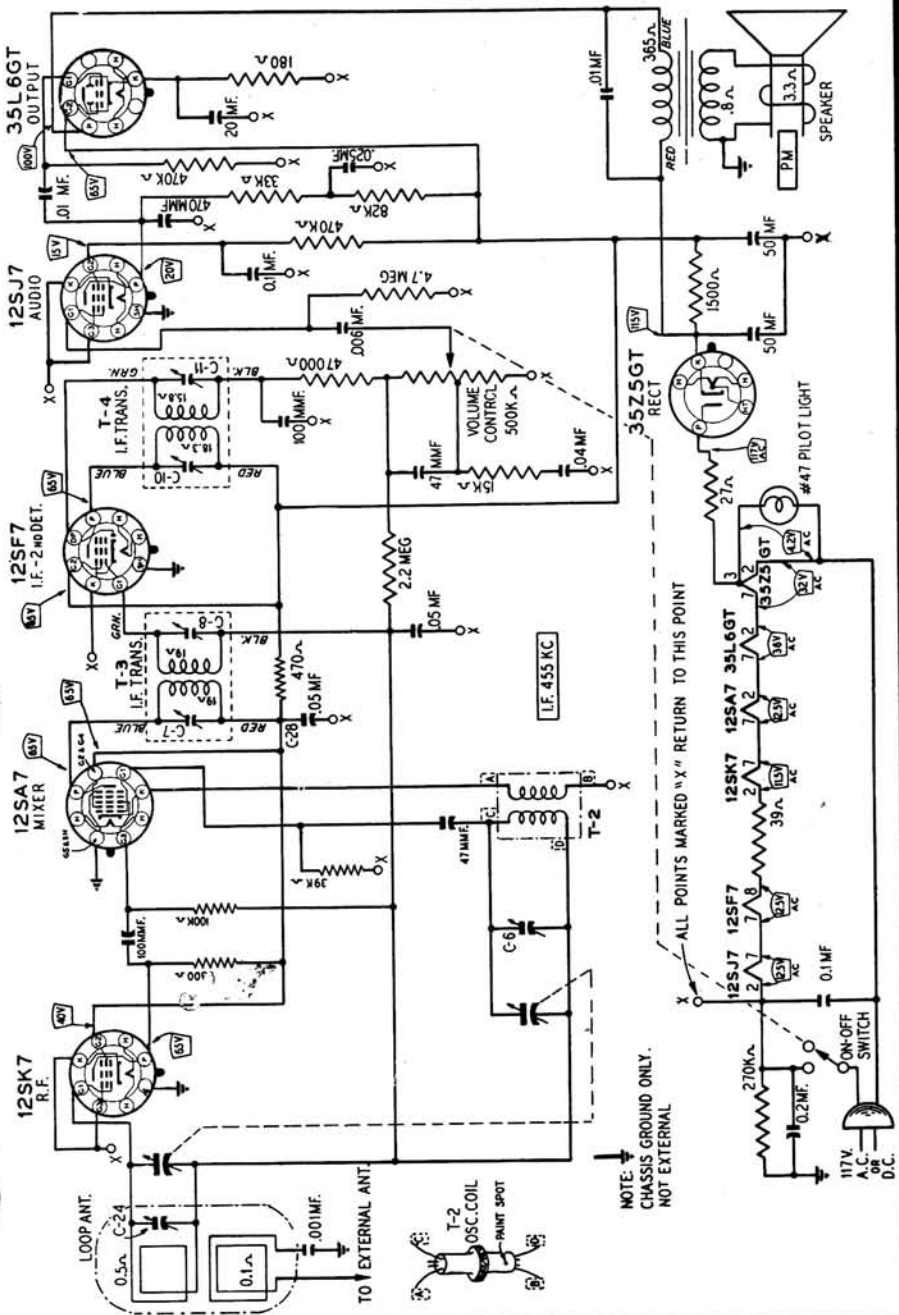

MANUAL OF 1948 MOST-OFTEN-NEEDED RADIO DIAGRAMS

SIGNAL GENERATOR				CONDENSER SETTING	ADJUST TRIMMERS TO MAXIMUM See Trimmer Illustration
Frequency Setting	Coupling Capacitor	Connection To Radio	Ground Connection		
455 kc	.1 mf	Control Grid 12SK7—1-F Prong No. 4	Point "X" 12SK7—1-F Prong No. 3	Turn Rotor to full open	2nd I-F (C7) & (C8)
455 kc	.1 mf	Control Grid 12SA7—1st Det. Prong No. 8	Same as above	Turn Rotor to full open	1st I-F (C5) & (C6)
1620 kc	.1 mf	Control Grid 12SA7—1st Det. Prong No. 8	Same as above	Turn Rotor to full open	Oscillator (C4)
1400 kc	50 mmf	External Antenna Clip on Loop See Note A	Chassis	Tune Rotor to Max. Output Set Indicator to 1400 KC— See Note B	Antenna (C19)

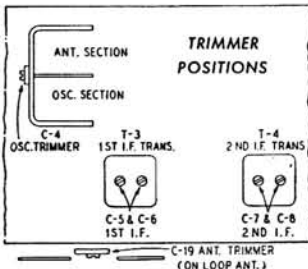

WARDS

74 WG-1802A
74 WG-1803A

NOTE A—Re-assemble chassis in cabinet. Replace back on cabinet.

NOTE B—Tune in a 1400 KC signal. If pointer is not at the 1400 KC mark on the dial scale, pull pointer off shaft. Set pointer at the 1400 KC mark and push back on shaft.

Model 74WG-2004 is similar, but has phono.

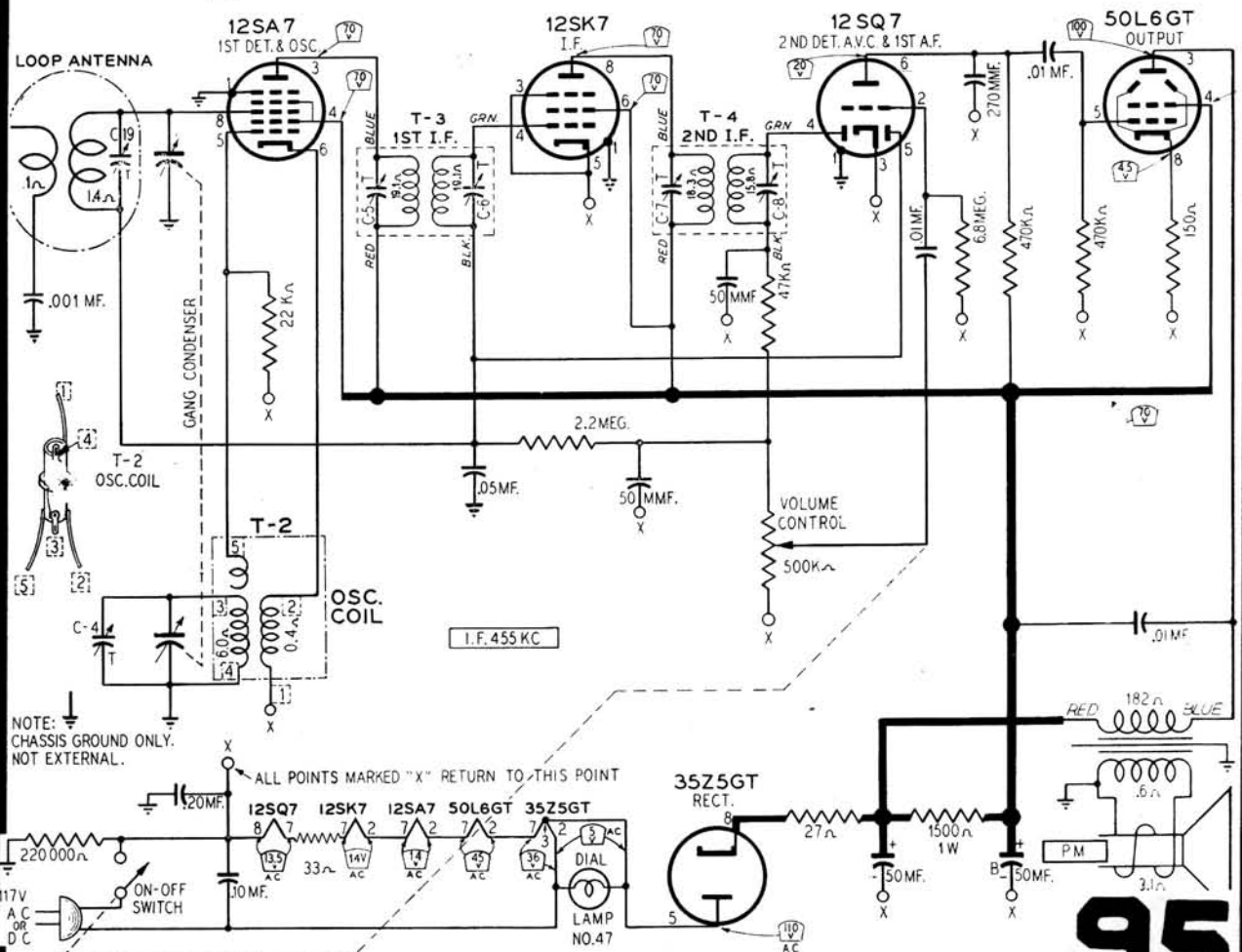

NOTE: CHASSIS GROUND ONLY. NOT EXTERNAL.

ALL POINTS MARKED "X" RETURN TO THIS POINT

MANUAL OF 1948 MOST-OFTEN-NEEDED RADIO DIAGRAMS

M O N T G O M E R Y W A R D

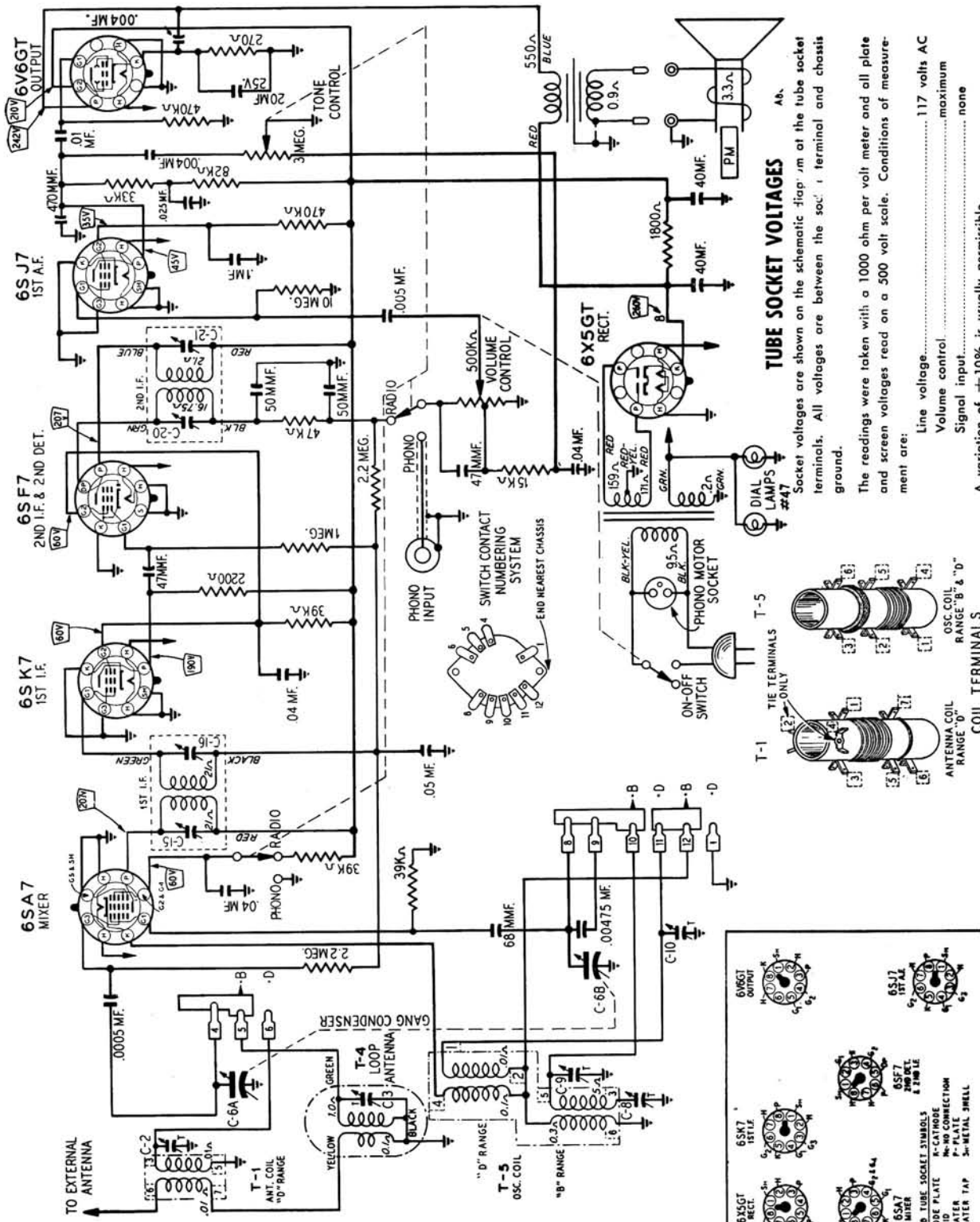

TUBE SOCKET VOLTAGES

Socket voltages are shown on the schematic diagram at the tube socket terminals. All voltages are between the socket terminal and chassis ground.

The readings were taken with a 1000 ohm per volt meter and all plate and screen voltages read on a 500 volt scale. Conditions of measurement are:

- Line voltage..... 117 volts AC
- Volume control..... maximum
- Signal input..... none
- A variation of ±10% is usually permissible.

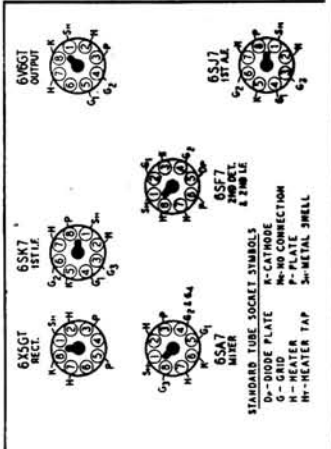
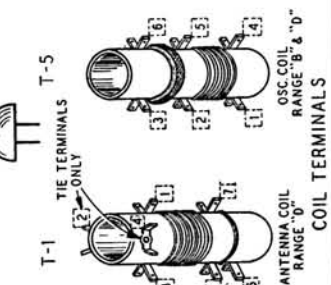

96

Montgomery Ward Model 74WG-2504C
 (Model 74WG-2704C is similar)
 See page 97 for more details.

MANUAL OF 1948 MOST-OFTEN-NEEDED RADIO DIAGRAMS

WARDS *Airline* RADIO

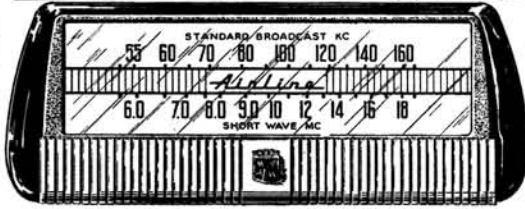

MODEL 74 WG-2504C

(Model 74WG-2704C is similar)
See page 96 for schematic.

Frequency Range.....B range—540-1600 KC
D range—5.75 to 18.3 MC

Intermediate Frequency..455 KC

DRIVE CORD REPLACEMENT

Turn the gang condenser to the fully open position. Use a new 10X65 drive cord assembly or a piece of cord 48 inches long and tie one end to the tension spring. Hook the other end of the tension spring to the tab on the drive pulley. Pass the cord through the slot in the drive pulley rim around idler stud A and wind three and one-half turns clockwise around the tuning shaft (turns must progress away from chassis). Then pass cord over idler pulleys B and C. Wrap cord counterclockwise around drive pulley, stretch tension spring and fasten free end of cord to spring.

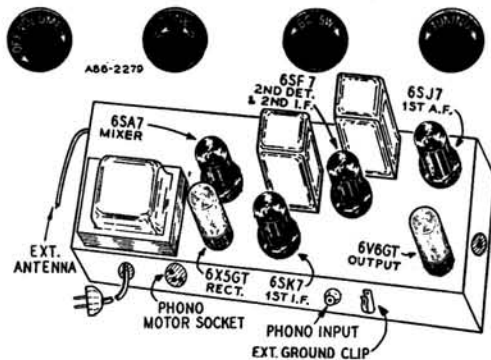

ALIGNMENT PROCEDURE

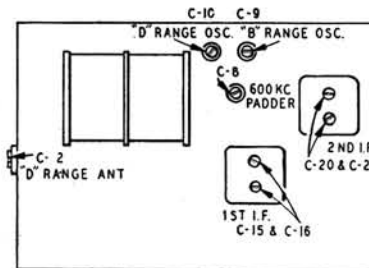

Volume Control—Maximum All Adjustments.
Connect Radio Chassis to Ground Post of Signal Generator with a Short Heavy Lead.
Allow Chassis and Signal Generator to "Heat Up" for several minutes.
The following equipment is required for aligning:
An All Wave Signal Generator which will provide an accurately calibrated signal at the test frequencies as listed.
Output Indicating Meter; Non-Metallic Screwdriver.
Dummy Antennas—.1 mf., 50 mmf., and 400 ohms.

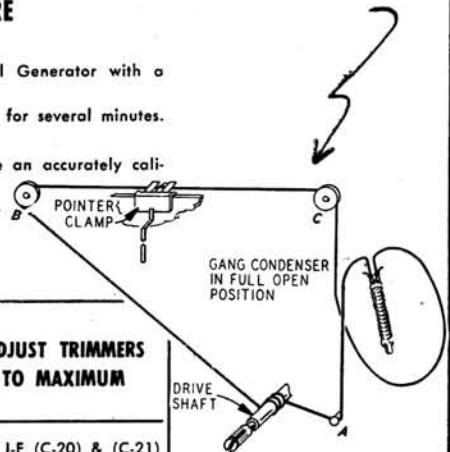

	SIGNAL GENERATOR		Dummy Antenna	Band Switch Setting	CONDENSER SETTING	ADJUST TRIMMERS TO MAXIMUM
	Frequency Setting	Connection at Radio				
I-F	455 kc	6SA7, Pin 8	.1 mf	B Range	Turn Rotor to Full Open	2nd I-F (C-20) & (C-21) 1st I-F (C-15) & (C-16)
RANGE B	1620 kc	Antenna Lead	50 mmf	B Range	Turn Rotor to Full Open	Oscillator Range B (C9)
	1400 kc	Antenna Lead	50 mmf	B Range	Tune Rotor to Max. Output. Set Indicator to 1400 KC. See Note A	Antenna Range B (C3)
	600 kc	Antenna Lead	50 mmf	B Range	Tune Rotor to Max. Output	600 kc (C8) Rock Rotor—See Note B

Repeat above oscillator adjustments at 1620 and 600 KC until readjusting the oscillator Range B Trimmer (C9) causes no further improvement in output.

RANGE D	18.3 mc	Antenna Lead	400 Ohm	D Range	Turn Rotor to Full Open	Oscillator Range D (C10)
	16 mc	Antenna Lead	400 Ohm	D Range	Tune Rotor to Max. Output	Antenna Range D (C2) Rock Rotor—See Note B
LOOP RANGE B	Reassemble chassis in cabinet.					
	1400 kc	Antenna Lead	50 mmf	B Range	Tune Rotor to Max. Output	Antenna Range B (C3)

After each range is completed, repeat the procedure as a final check.

NOTE A—If the pointer is not at 1400 KC on the dial, re-set pointer at the 1400 KC mark on the dial scale.

NOTE B—Turn the rotor back and forth and adjust the trimmer until the peak of greatest intensity is obtained.

MANUAL OF 1948 MOST-OFTEN-NEEDED RADIO DIAGRAMS

WARDS

MODEL 74 WG-2709A

See page 99 for alignment

ELECTRICAL SPECIFICATIONS

Power Supply..... 105-125 volts AC, 60 cycles,
55 watts normal, 77 watts phono
operating
Frequency Range..... B range—540-1600 KC
D range—5.75 to 18.3 MC
Intermediate Frequency..... 455 KC
Selectivity..... 43 KC broad at 1000 times signal,
1000 KC

TUBE SOCKET VOLTAGES

Socket voltages are shown on the schematic diagram at the tube socket terminals. All voltages are between the socket terminal and chassis ground.

The readings were taken with a 1000 ohm per volt meter and all plate and screen voltages read on a 500 volt scale.

Conditions of measurement are:

Line voltage..... 117 volts AC
Volume control..... maximum
Signal input..... none

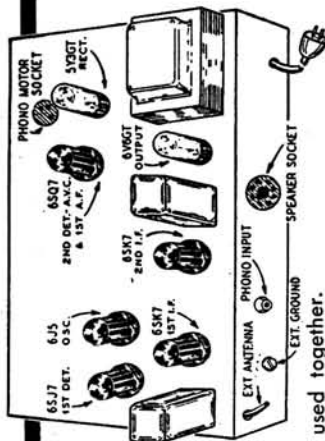

NOTE: Gimmick and 4.7 mmf capacitor used together.
7 mmf capacitor used without the gimmick.

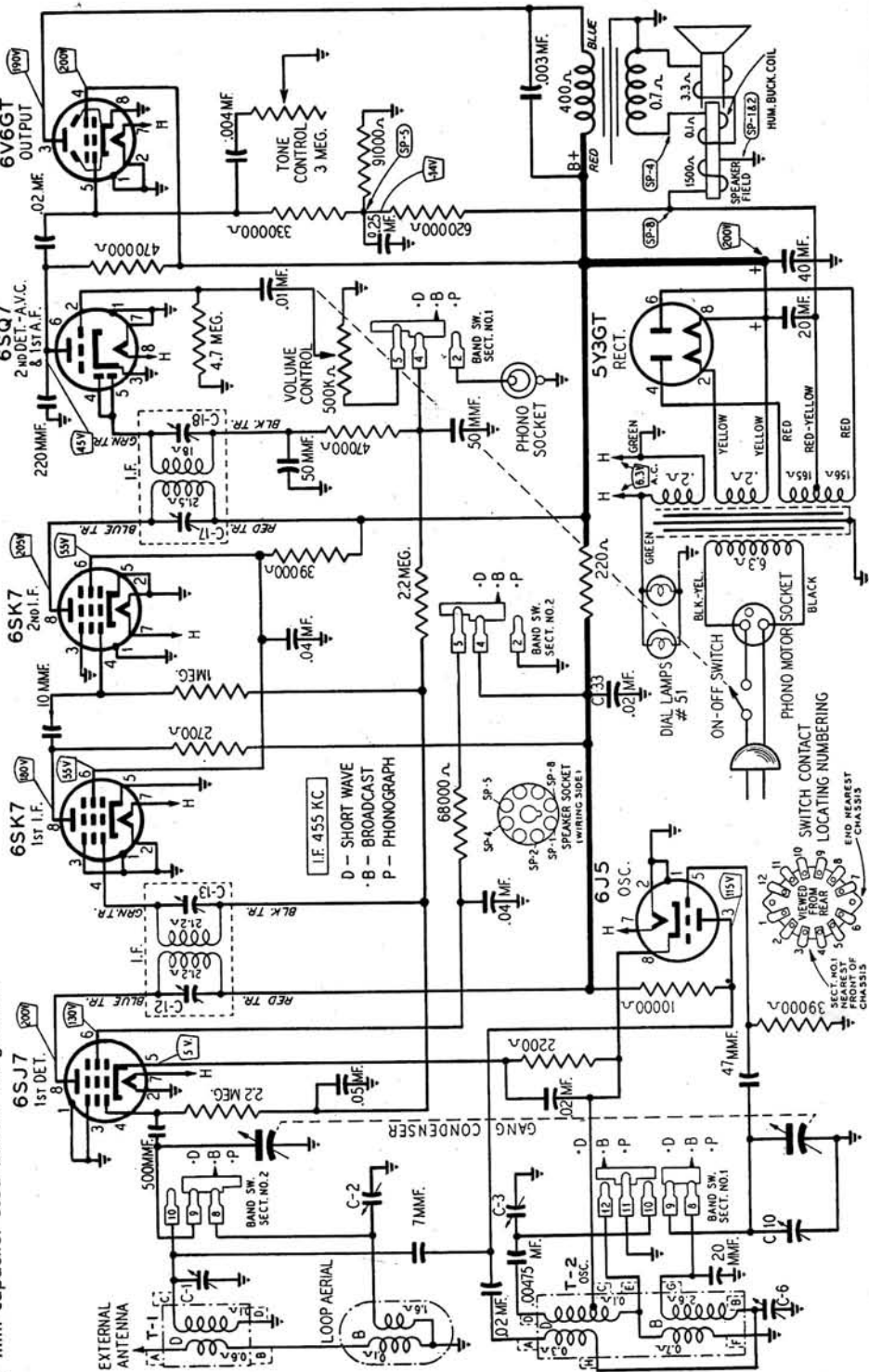

MANUAL OF 1948 MOST-OFTEN-NEEDED RADIO DIAGRAMS

WARDS *Airline*

MODEL 74 WG-2709A

Frequency Range..... B range—540-1600 KC
 D range—5.75 to 18.3 MC
 Intermediate Frequency .455 KC
 Selectivity 43 KC broad at 1000 times signal,
 1000 KC

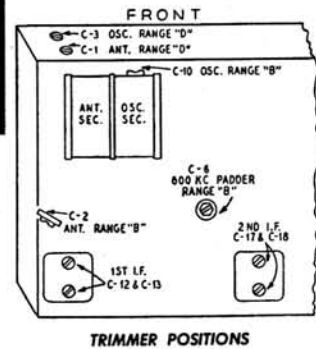

TRIMMER POSITIONS

ALIGNMENT PROCEDURE

Volume Control—Maximum All Adjustments.
 Connect Radio Chassis to Ground Post of Signal Generator with a Short Heavy Lead.
 Allow Chassis and Signal Generator to "Heat Up" for several minutes.

The following equipment is required for aligning:
 An All Wave Signal Generator which will provide an accurately calibrated signal at the test frequencies as listed.
 Output Indicating Meter; Non-Metallic Screwdriver.
 Dummy Antennas—.1 mf., 100 mmf., and 400 ohms.

	SIGNAL GENERATOR		Dummy Antenna	Band Switch Setting	Condenser Setting	ADJUST TRIMMERS TO MAXIMUM
	Frequency Setting	Connection at Radio				
I-F	455 kc	6SJ7, Pin 4	.1 mf	B Range	Turn Rotor to Full Open	2nd I-F (C17) & (C18) 1st I-F (C12) & (C13)
RANGE B	1600 kc	Antenna Lead	100 mmf	B Range	Turn Rotor to Full Open	Oscillator Range B (C10)
	1400 kc	Antenna Lead	100 mmf	B Range	Turn Rotor to Max. Output Set Indicator to 1400 KC See Note A	Antenna Range B (C2)
	600 kc	Antenna Lead	100 mmf	B Range	Turn Rotor to Max. Output	600 kc (C6) Rock Rotor—See Note B
Repeat above oscillator adjustments at 1600 and 600 kc until readjusting the oscillator Range B Trimmer (C10) causes no further improvement in output.						
RANGE D	18,300 kc	Antenna Lead	400 Ohm	D Range	Turn Rotor to Full Open	Oscillator Range D (C3)
	17,000 kc	Antenna Lead	400 Ohm	D Range	Turn Rotor to Max. Output	Antenna Range D (C1) Rock Rotor—See Note B
LOOP RANGE B	Reassemble chassis in cabinet. 1400 kc	Antenna Lead	100 mmf	B Range	Turn Rotor to Max. Output	Antenna Range B (C2)

After each range is completed, repeat the procedure as a final check.

NOTE A—If the pointer is not at 1400 KC on the dial, re-set

pointer at the 1400 KC mark on the dial scale.

NOTE B—Turn the rotor back and forth and adjust the trimmer until the peak of greatest intensity is obtained.

DRIVE CORD REPLACEMENT

Turn the gang condenser to the fully open position. Use a new 10X64 drive cord or a piece of cord 46" long and tie one end to the tension spring. Hook the other end of the tension spring to the tab on the drive pulley. Pass the cord through the slot in the drive pulley rim and continue one half turn counterclockwise around the drive pulley. Then pass the cord around idler stud A and wind three turns clockwise around the tuning shaft (turns must progress away from chassis). Pass cord through string guide B, over pulleys C and D and around idler stud E. Wrap 3/4 turn counterclockwise around drive pulley, stretch the tension spring and tie free end of the cord to spring.

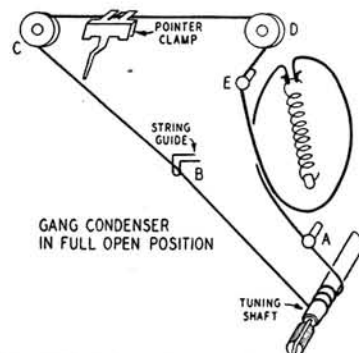

MANUAL OF 1948 MOST-OFTEN-NEEDED RADIO DIAGRAMS

Montgomery Ward Model 74WG-2010B (Alignment on page 101)

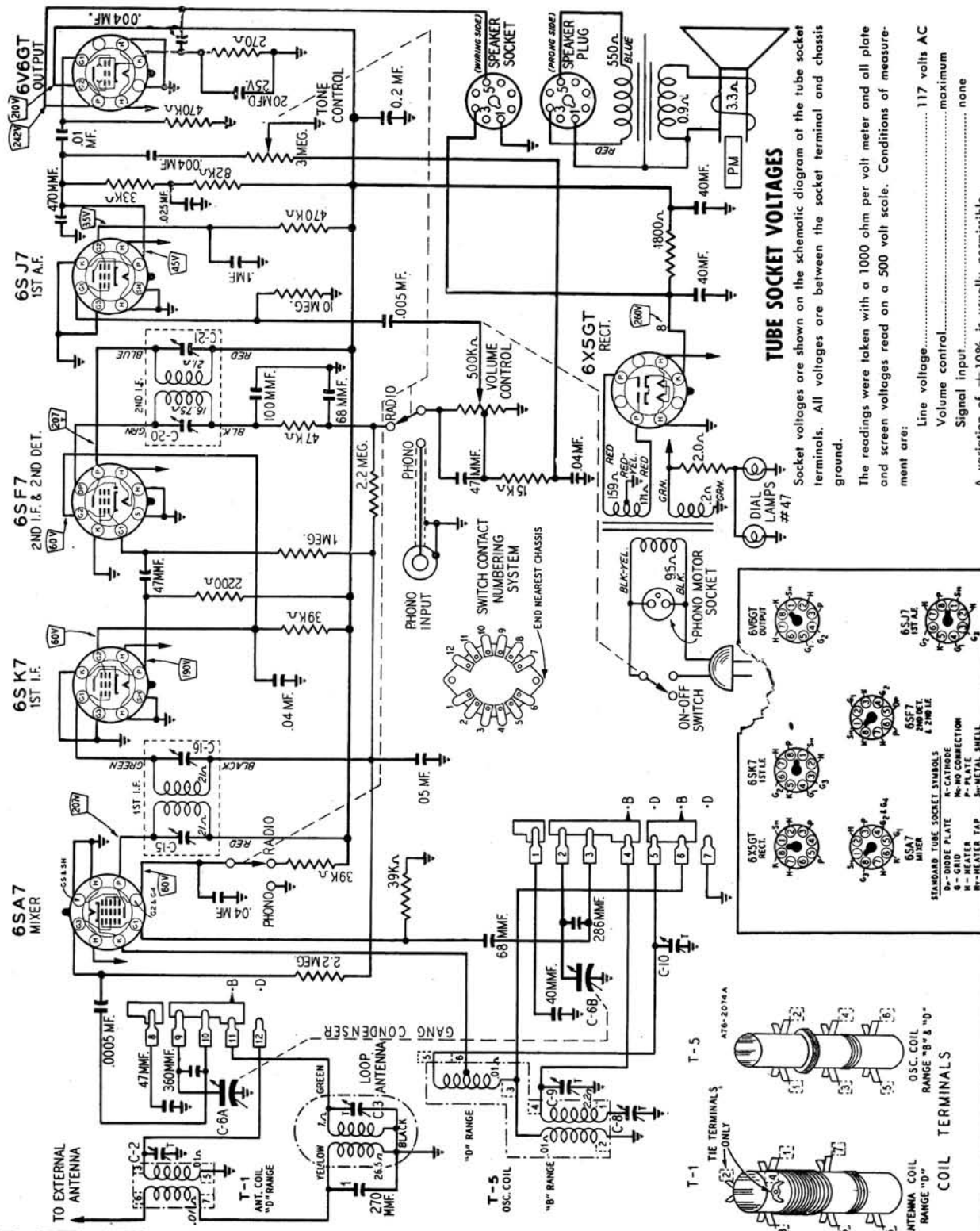

MANUAL OF 1948 MOST-OFTEN-NEEDED RADIO DIAGRAMS

WARDS

MODEL 74 WG-2010B

Frequency Range.....B range—540-1600 KC
D range—9 to 15.5 MC

Intermediate Frequency...455 KC

Selectivity.....40 KC broad at 1000 times signal,
1000 KC

Sensitivity.....(for .5 watt output) with external antenna
B range—9 microvolts average
D range—20 microvolts average

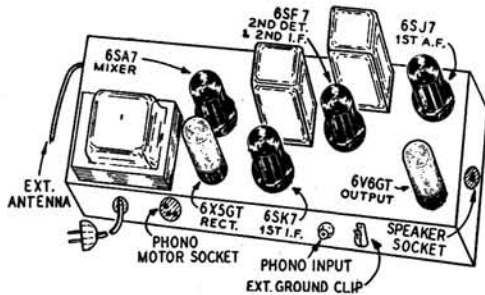

ALIGNMENT PROCEDURE

Volume Control—Maximum All Adjustments.

Connect Radio Chassis to Ground Post of Signal Generator with a Short Heavy Lead.

Allow Chassis and Signal Generator to "Heat Up" for several minutes.

The following equipment is required for aligning:
An All Wave Signal Generator which will provide an accurately calibrated signal at the test frequencies as listed.
Output Indicating Meter; Non-Metallic Screwdriver.
Dummy Antennas—.1 mf., 100 mmf., and 400 ohms.

DRIVE CORD REPLACEMENT

Turn the gang condenser to the fully open position. Use a new drive cord 46" long and tie one end to the tension spring. Hook the other end of the tension spring to the tab on the drive pulley. Pass the cord through the slot in the drive pulley rim and continue one and one-half turns counterclockwise around the drive pulley. Then pass the cord around idler stud A and wind three and one-half turns clockwise around the tuning shaft (turns must progress away from chassis). Pass cord around pulleys B and C and around idler stud D. Wrap cord counterclockwise around drive pulley, stretch the tension spring and tie free end of the cord to spring. Cut off any excess string.

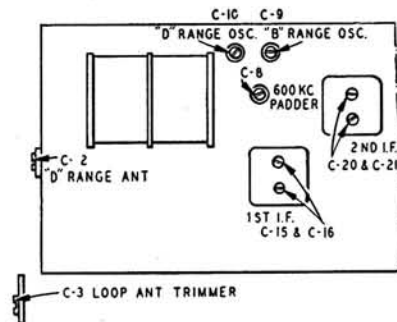
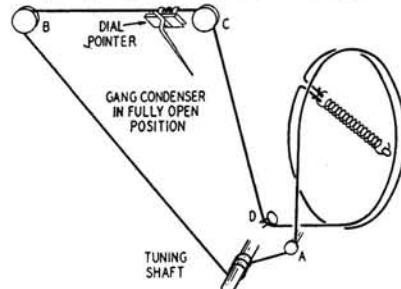

	SIGNAL GENERATOR		Dummy Antenna	Band Switch Setting	CONDENSER SETTING	ADJUST TRIMMERS TO MAXIMUM
	Frequency Setting	Connection at Radio				
I-F	455 kc	6SA7, Pin 8	.1 mf	B Range	Turn Rotor to Full Open	2nd I-F (C-20) & (C-21) 1st I-F (C-15) & (C-16)
RANGE B	1620 kc	Antenna Lead	100 mmf	B Range	Turn Rotor to Full Open	Oscillator Range B (C9)
	1400 kc	Antenna Lead	100 mmf	B Range	Tune Rotor to Max. Output. Set Indicator to 1400 KC. See Note A	Antenna Range B (C3)
	600 kc	Antenna Lead	100 mmf	B Range	Tune Rotor to Max. Output	600 kc (C8) Rock-Rotor—See Note B
Repeat above oscillator adjustments at 1620 and 600 KC until readjusting the oscillator Range B Trimmer (C9) causes no further improvement in output.						
RANGE D	15.6 mc	Antenna Lead	400 Ohm	D Range	Turn Rotor to Full Open	Oscillator Range D (C10)
	14 mc	Antenna Lead	400 Ohm	D Range	Tune Rotor to Max. Output	Antenna Range D (C2) Rock Rotor—See Note B
LOOP RANGE B	Reassemble chassis in cabinet. 1400 kc Antenna Lead		100 mmf	B Range	Tune Rotor to Max. Output	Antenna Range B (C3)

After each range is completed, repeat the procedure as a final check.

NOTE A—If the pointer is not at 1400 KC on the dial, re-set pointer at the 1400 KC mark on the dial scale.

NOTE B—Turn the rotor back and forth and adjust the trimmer until the peak of greatest intensity is obtained.

Montgomery Ward
Model 74WG-2705A
Alignment on page 103.

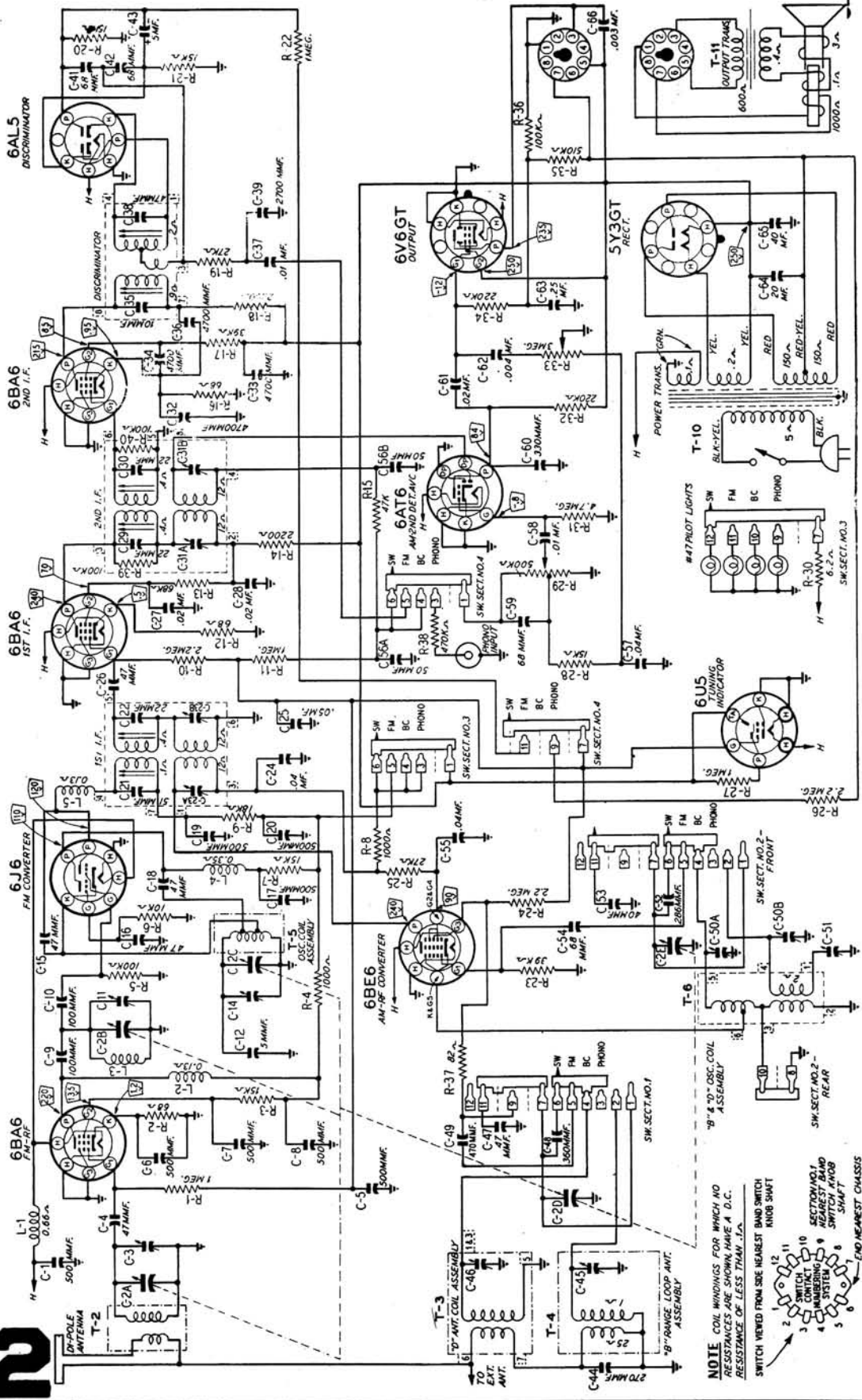
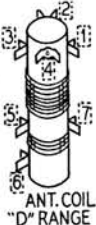
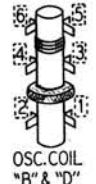
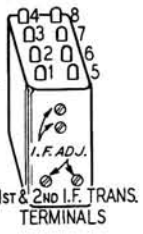

NOTE: COIL WINDINGS FOR WHICH NO RESISTANCES ARE SHOWN HAVE A D.C. RESISTANCE OF LESS THAN 1 Ω.

SWITCH WOUND FROM SIDE NEAREST BAND SWITCH KNOB SWAIT

SECTION NO. 1 CONTACT NEAREST BAND SWITCH KNOB SWAIT

SECTION NO. 2 CONTACT NEAREST BAND SWITCH KNOB SWAIT

SECTION NO. 3 CONTACT NEAREST BAND SWITCH KNOB SWAIT

SECTION NO. 4 CONTACT NEAREST BAND SWITCH KNOB SWAIT

SECTION NO. 5 CONTACT NEAREST BAND SWITCH KNOB SWAIT

SECTION NO. 6 CONTACT NEAREST BAND SWITCH KNOB SWAIT

SECTION NO. 7 CONTACT NEAREST BAND SWITCH KNOB SWAIT

SECTION NO. 8 CONTACT NEAREST BAND SWITCH KNOB SWAIT

SECTION NO. 9 CONTACT NEAREST BAND SWITCH KNOB SWAIT

SECTION NO. 10 CONTACT NEAREST BAND SWITCH KNOB SWAIT

SECTION NO. 11 CONTACT NEAREST BAND SWITCH KNOB SWAIT

SECTION NO. 12 CONTACT NEAREST BAND SWITCH KNOB SWAIT

MANUAL OF 1948 MOST-OFTEN-NEEDED RADIO DIAGRAMS

WARDS *Airline*

MODEL 74WG-2705A

	SIGNAL GENERATOR		DUMMY ANTENNA	BAND SWITCH SETTING	CONDENSER SETTING	ADJUST TRIMMERS TO MAXIMUM
	FREQUENCY SETTING	CONNECTION AT RADIO				
I-F	455 kc.	6BE6 Pin 7	.1 mf	Broadcast	Rotor Fully Open	2nd I-F C-31B & C-31A 1st I-F C-23B & C-23A
Broadcast	1620 kc	External ant. lead	200 mmf	Broadcast	Rotor Fully Open	Oscillator C-50B
	1400 kc	External antenna lead	200 mmf	Broadcast	Turn Rotor to Max. Output Set pointer to 1400 kc See Note A	Antenna C-45
	600 kc	External antenna lead	200 mmf	Broadcast	Turn Rotor to Max. Output and Rock See Note B	600 Kc padder C-51
Repeat above oscillator adjustments at 1620 and 600 KC until readjusting the oscillator Range B Trimmer C-50B causes no further improvement in output.						
Short Wave	15.5 MC	External antenna lead	400 ohm	Short Wave	Rotor Fully Open	Oscillator C-50A
	15 MC	External antenna lead	400 ohm	Short Wave	Turn Rotor to Max. Output	Antenna C-46
Reassemble chassis in cabinet						
Broadcast	1400 kc	External antenna lead	200 mmf	Broadcast	Turn Rotor to Max. Output	Antenna C-45

After each range is completed, repeat the procedure as a final check.
Note A—If the pointer is not at 1400 KC on the dial, reset pointer at the 1400 KC mark on the dial scale.

Note B—Turn the rotor back and forth and adjust the trimmer until the peak of greatest intensity is obtained.

Discriminator	10.7 MC Note B	6BA6 2nd I-F Pin 1 and Chassis	.01 mf	FM	Rotor to Full Open	Disc. Pri. ① Note A
	10.7 MC Note B	Same as above	.01 mf	FM	Same as above	Disc. Sec. Note C ②
	10.7 MC Note B	Same as above	.01 mf	FM	Same as above	Disc. Pri. ① Note A
	10.7 MC Note B	Same as above	.01 mf	FM	Same as above	Disc. Sec. Note C ②
I-F	10.7 MC	6BA6 1st I-F, Pin 1 and Chassis	.01 mf	FM	Same as above	2nd I-F Pri. Note A and D ③ 2nd I-F Sec. Note A and E ④
	10.7 MC	Connect to the FM-RF Gang Condenser terminal on underside of chassis	.01 mf	FM	Same as above	1st I-F Pri. ⑤ 1st I-F Sec. ⑥ Note A
Recheck I-F Adjustments in order given						
R-F & Osc.	108.4	Disconnect dipole and connect generator to dipole terminals with resistor in series	300 ohms	FM	Rotor to full open	Oscillator C-14
	104.5	Same as above	300 ohms	FM	Tune Rotor for Max. AVC voltage	R.F. C-11
	104.5	Same as above	300 ohms	FM	Same as above	Ant. C-3
Recheck R-F and Osc. Adjustments in order given						

Note A—Test Equipment connections are as given in the table. The zero center scale DC vacuum tube voltmeter is to be connected between chassis ground and the AVC line at the 1 megohm resistor R-22 and the band switch terminal (as shown in the illustration) for all adjustments except the discriminator secondary adjustment, for which see Note C.

Note B—A signal of .1 volt must be fed into the receiver for this adjustment.

Note C—Disconnect zero center DC vacuum tube voltmeter from AVC and reconnect to junction of R-19, C-37 and C-39 (See illustration). Adjust for zero voltage indication.

Note D—Before adjusting Pri. core connect 5000 ohm load resistor across the 2nd I.F. secondary terminals, (See illustration).

Note E—Disconnect 5000 ohm load resistor from secondary terminals and reconnect across the 2nd I.F. primary terminals, (See illustration).

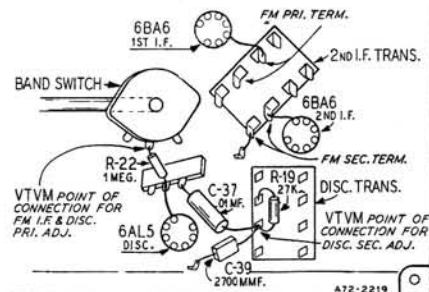
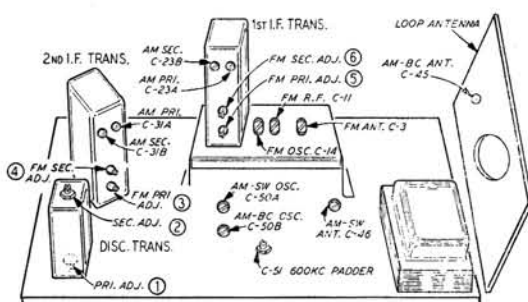

MANUAL OF 1948 MOST-OFTEN-NEEDED RADIO DIAGRAMS

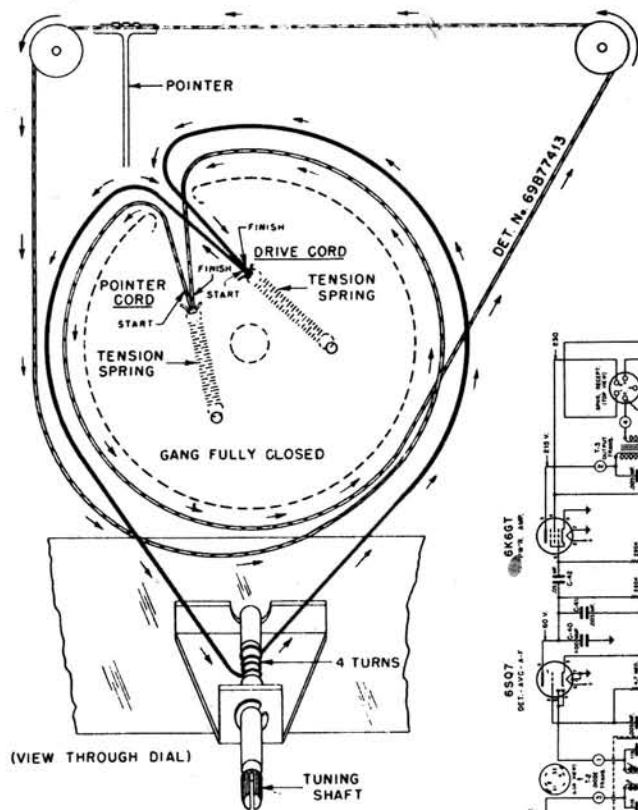

STRING DRIVE DETAIL

WAVEBAND SWITCH (K).

- "A" position - 532 to 1620 Kc.
- "B" position - 3.0 to 9.1 Mc.
- "C" position - 8.8 to 10.6 Mc.
- "D" position - 10.5 to 13.9 Mc.
- "E" position - 13.8 to 16.6 Mc.
- "F" position - 16.5 to 22.5 Mc.

Motorola

MODEL 67F61BN

CHASSIS HS-69

See page 105 for more details.

104

MOTOROLA
Model 67F61BN
Chassis HS-69

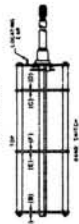
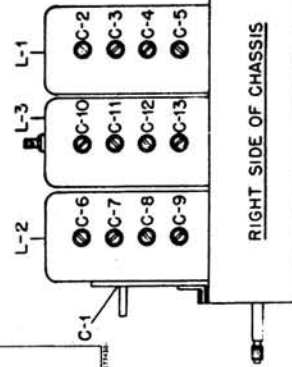
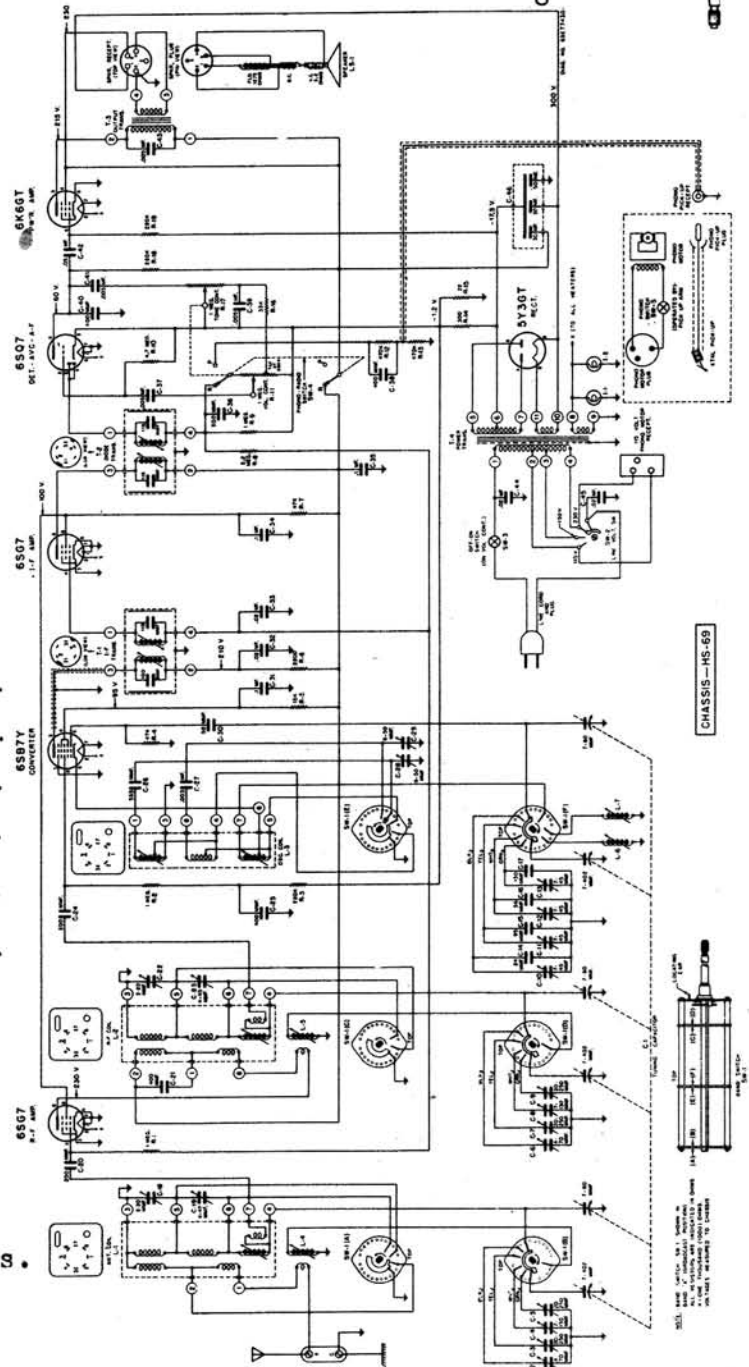

SEE PAGE 105 FOR MORE DETAILS ON HOW TO LOCATE AND IDENTIFY COMPONENTS IN THIS MANUAL TO CHASSIS

MANUAL OF 1948 MOST-OFTEN-NEEDED RADIO DIAGRAMS

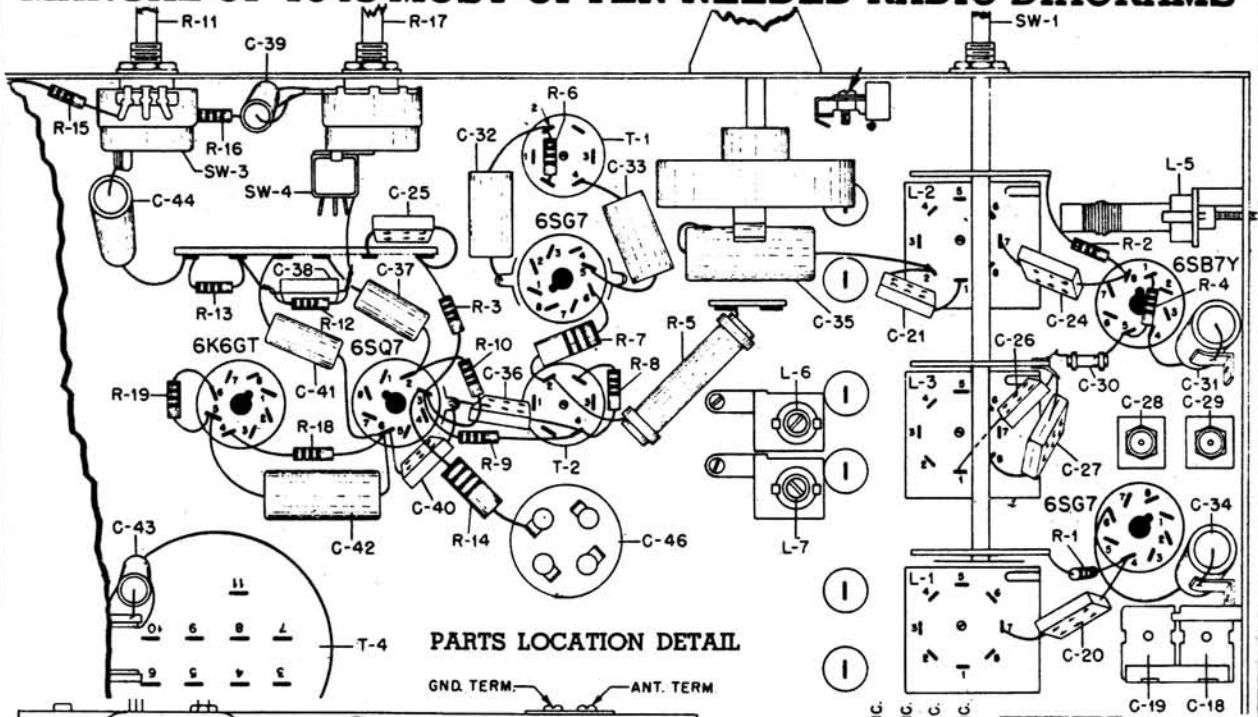

PARTS LOCATION DETAIL

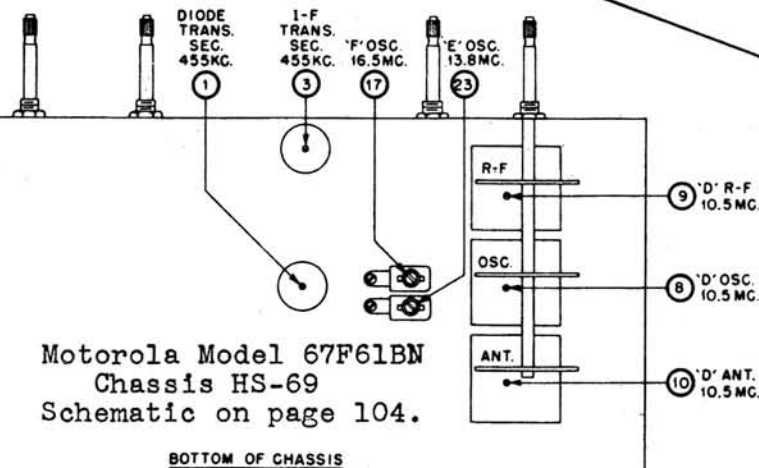
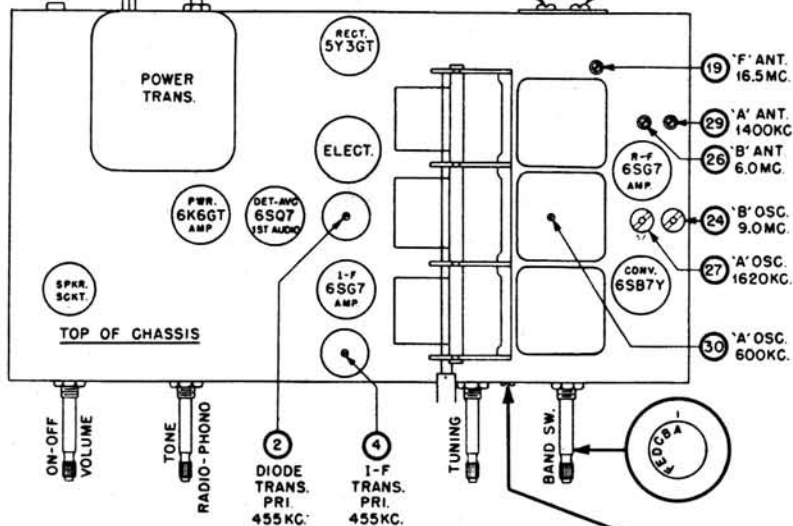

Motorola Model 67F61BN
Chassis HS-69
Schematic on page 104.

BOTTOM OF CHASSIS

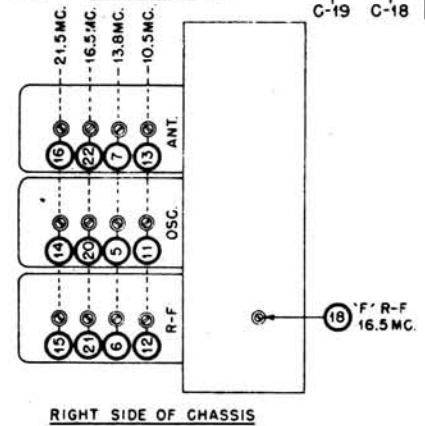

RIGHT SIDE OF CHASSIS

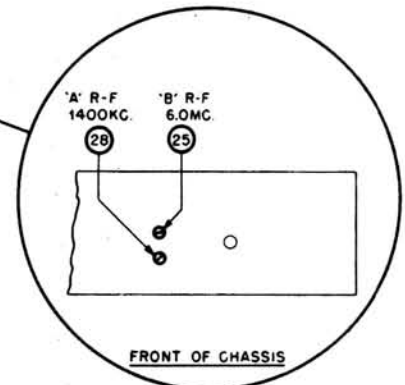

FRONT OF CHASSIS

TUBE AND TRIMMER LOCATIONS

MANUAL OF 1948 MOST-OFTEN-NEEDED R

Motorola
MODEL 47B11

Motorola
MODEL 47B11

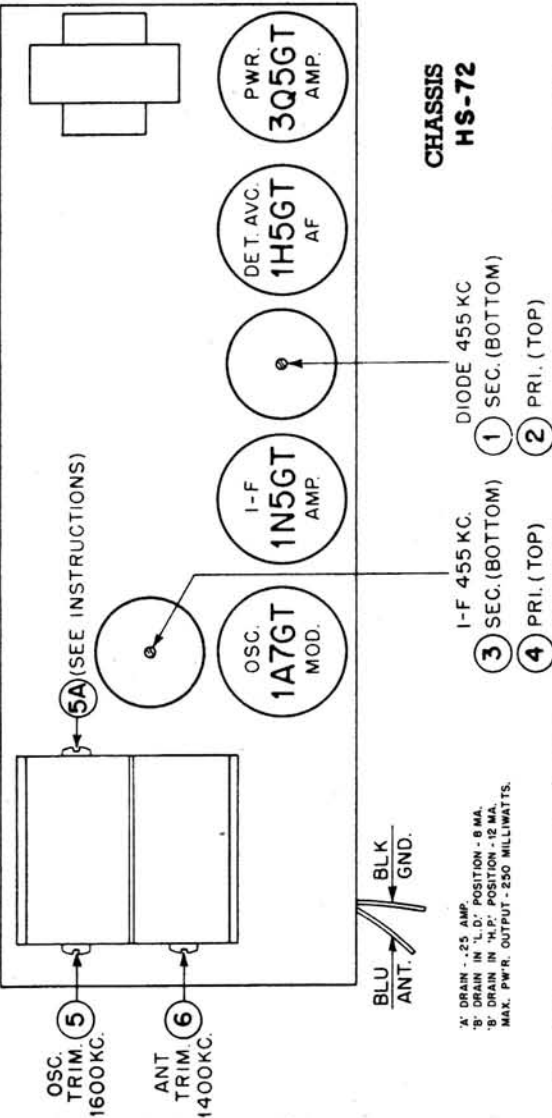
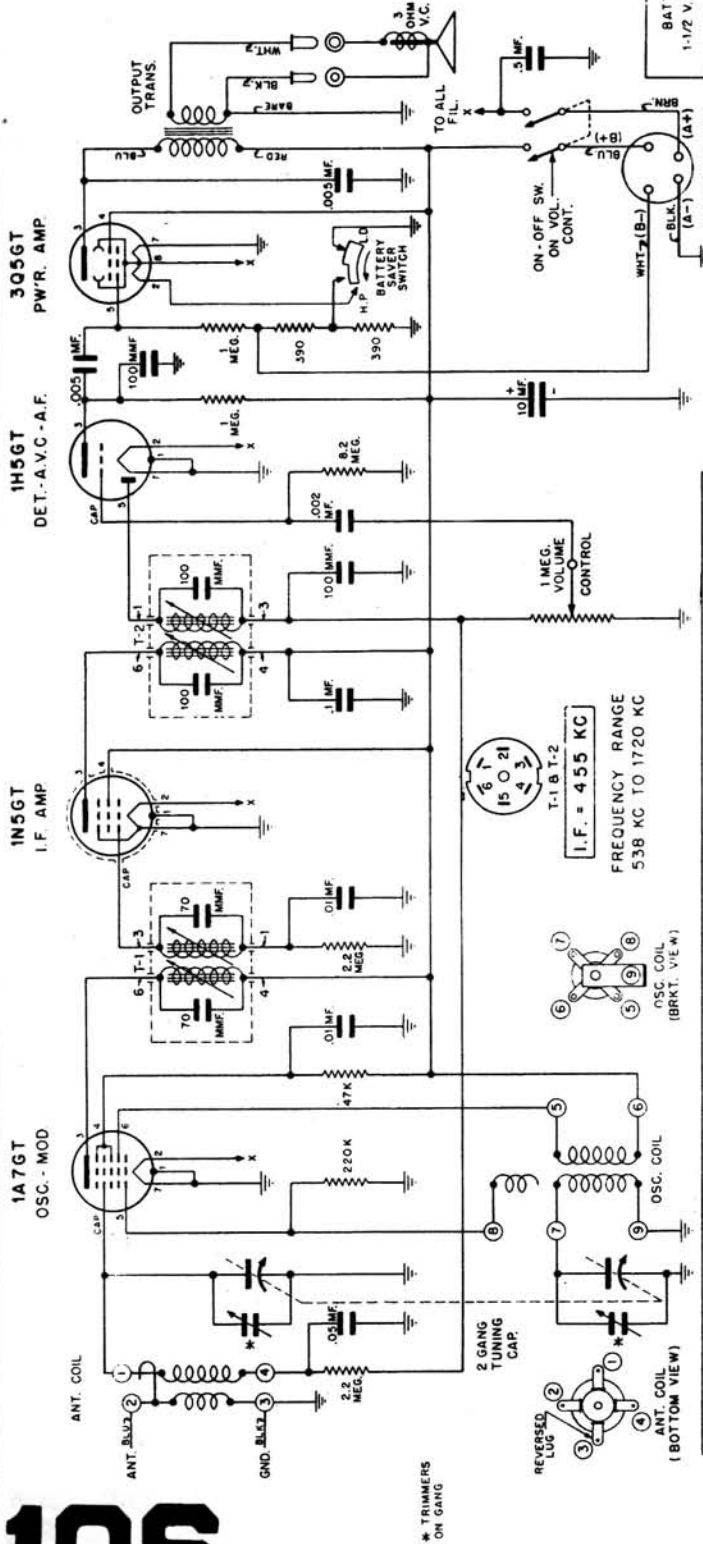

CHASSIS HS-72

- 1-F 455 KC.
 - ③ SEC. (BOTTOM)
 - ④ PRI. (TOP)
- DIODE 455 KC
 - ① SEC. (BOTTOM)
 - ② PRI. (TOP)

* A DRAIN - .25 AMP.
 * B DRAIN IN "D" POSITION - 8 MA.
 * C DRAIN IN "E" POSITION - 10 MA.
 MAX. P.W.R. OUTPUT - 250 MILLIWATTS.

MANUAL OF 1948 MOST-OFTEN-NEEDED RADIO DIAGRAMS

MOTOROLA INC.

Models 57X11, 57X12
Chassis HS-60
Alignment page 108

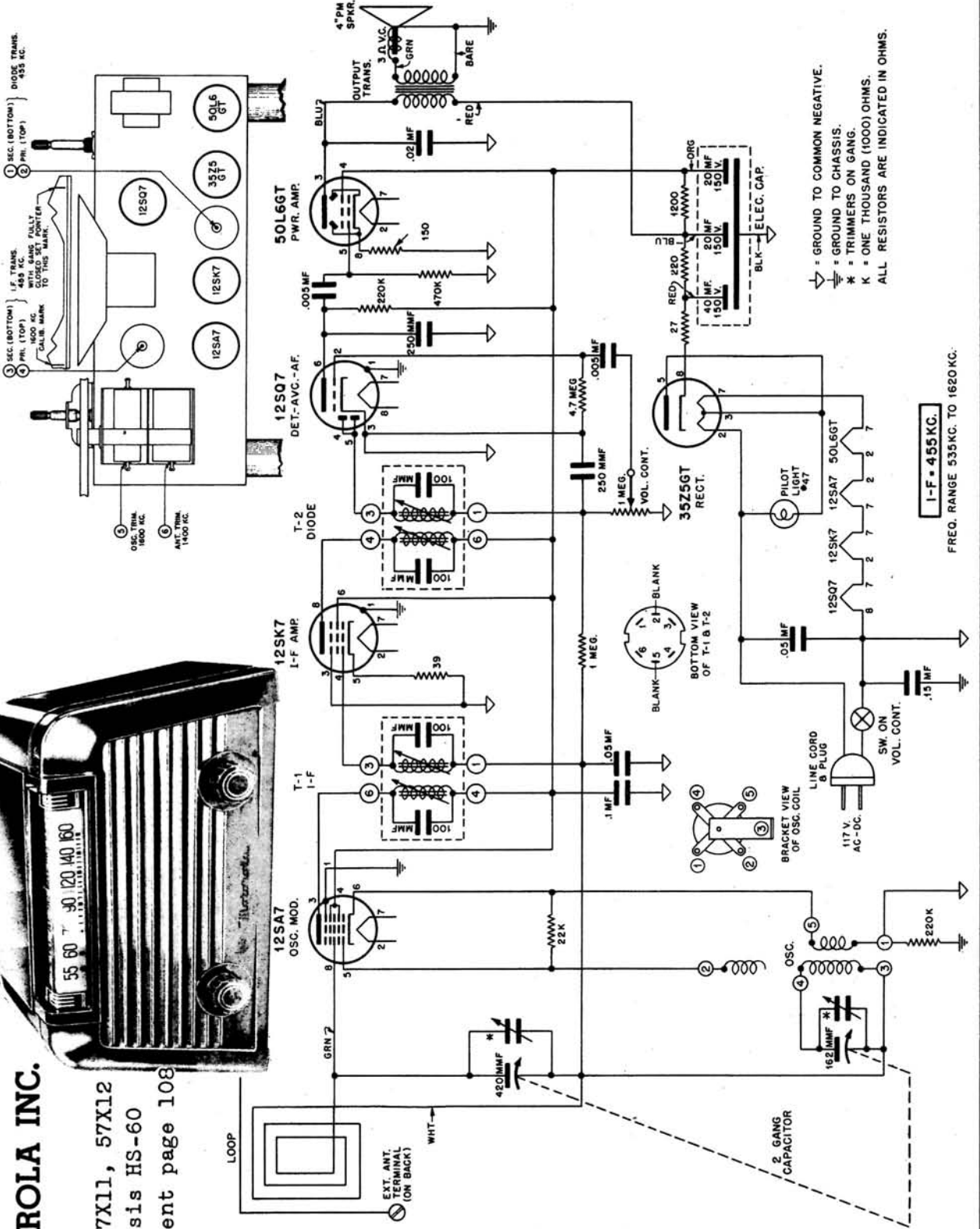

Motorola Models 57X11, 57X12, Chassis HS-60

MANUAL OF 1948 MOST-OFTEN-NEEDED RADIO DIAGRAMS

Motorola

CHASSIS
HS-60

MODELS 57X11 & 57X12

A low range output meter should be connected across the speaker voice coil. Set receiver volume control to maximum; for greatest accuracy keep output of receiver at approximately .05 watt throughout alignment by reducing generator output (not receiver volume control) as stages are brought into alignment. (.05 watt = .40 volt on output meter). The alignment tool should be of an insulated type.

If receiver is operated from AC line during alignment, it is suggested that an isolating transformer be used between receiver and power line. If no isolation transformer is used and hum is encountered during alignment, connect the ground side of the signal generator to B- instead of the receiver chassis.

STEP	DIAL SET TO	DUMMY	SIGNAL GENERATOR CONNECTED TO	SIGNAL GENERATOR SET TO	ADJUST TRIMMER OR CORE	REMARKS
IF ALIGNMENT						
1.	Gang fully opened	.1 mf.	Osc-Mod grid *	455 Kc	1,2,3 & 4	Adjust for maximum
RF ALIGNMENT						
2.	1600 Kc **	-	Radiation loop ***	1600 Kc	5	This sets osc. to dial scale
3.	1400 Kc	-	Radiation loop ***	1400 Kc	6	Tune signal for max. with receiver tuning knob, then peak trimmer 6.

* A convenient point is the stator of the antenna section of the tuning capacitor.

** Close gang fully and set pointer to calibration mark at left hand side of dial background; then set pointer to 1600 Kc by turning tuning knob till pointer lines up with right hand calibration mark.

*** Connect output of signal generator to a 5" diameter, 3 turn loop and bring loop close enough to receiver loop to obtain output of 50 milliwatts (.40V) on output meter. Vary distance between loops to maintain this output during alignment. Minimum distance between loops should never be less than 12".

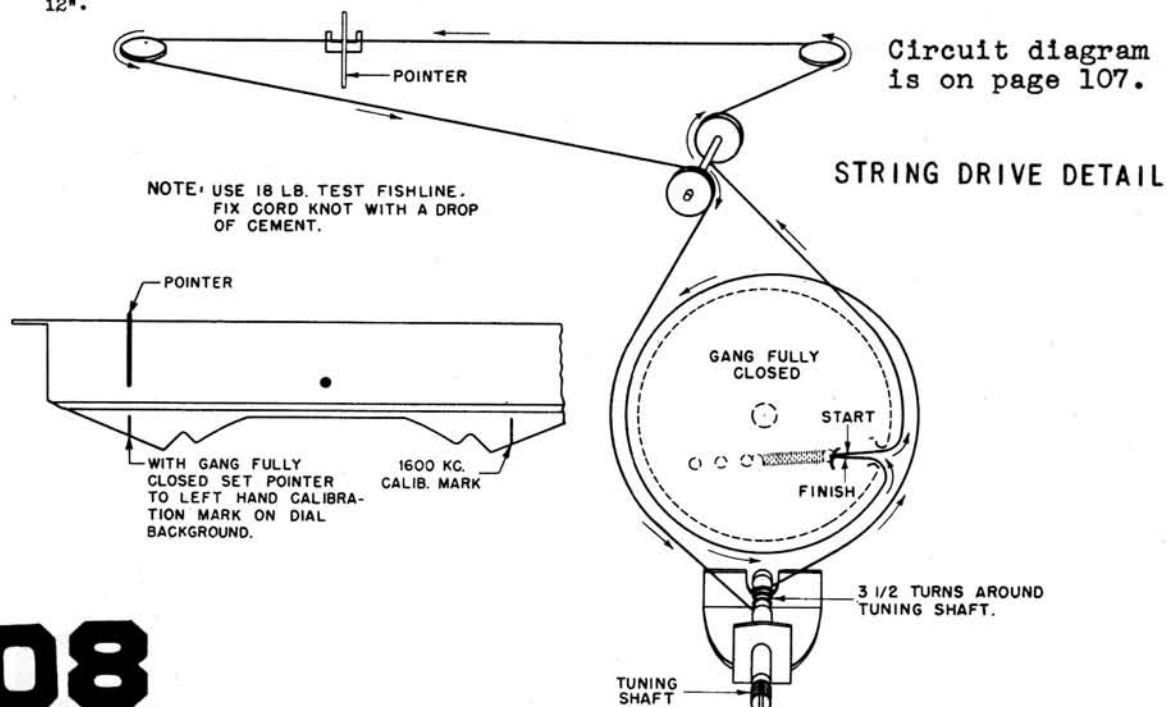

MANUAL OF 1948 MOST-OFTEN-NEEDED RADIO DIAGRAMS

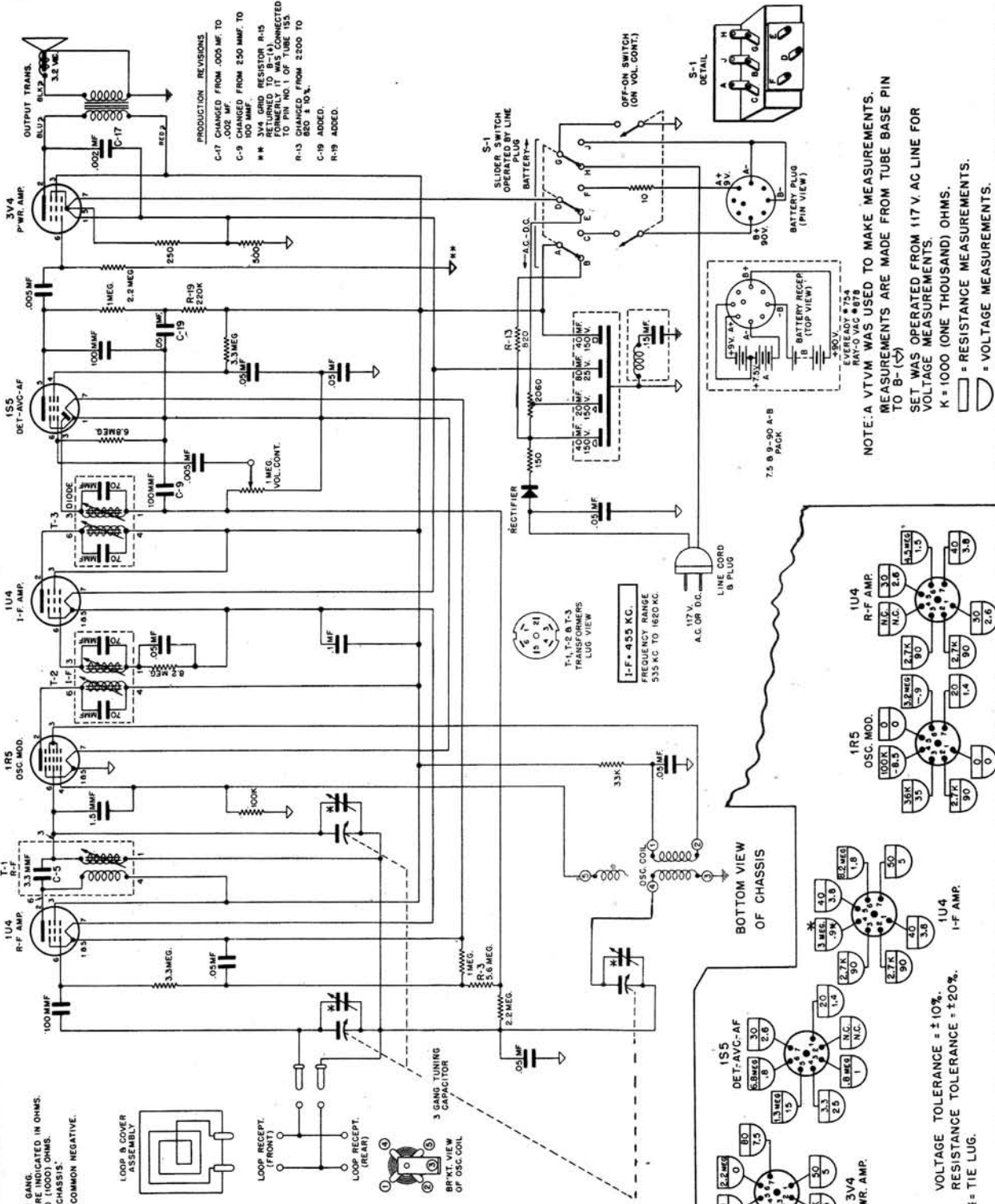

MANUAL OF 1948 MOST-OFTEN-NEEDED RADIO DIAGRAMS

MOTOROLA INC.

Model 67L11, Chassis HS-59
Schematic on page 109.

Normally, alignment can be made with trimmers 5, 6 and 7. However, if range of these trimmers is insufficient to obtain peak, adjustment can be made with trimmers 5A, 6A and 7A.

R.F. COIL. The inductance of this coil is set at time of manufacture by adjusting the iron core. No resetting of this core should be made unless it has been tampered with. If so, readjustment can be made by proceeding as follows:

Tune in 600 Kc signal and peak Padder Adj. (8). Next tune in 1400 Kc signal and peak trimmer (6). Repeat both adjustments until maximum response is obtained at both ends; the last adjustment should be trimmer (6).

STEP	DIAL SET TO	DUMMY	SIGNAL GENERATOR CONNECTED TO	SIGNAL GENERATOR SET TO	ADJUST TRIMMER OR CORE	REMARKS
IF ALIGNMENT						
1.	Gang fully opened.	.1 mf	OSC-MOD grid*	455 Kc	1,2,3 & 4	Adjust for maximum output
RF ALIGNMENT						
2.	1600 KC**	-	Radiation loop***	1600 Kc	5	This sets osc. to dial scale.
3.	1400 Kc	-	Radiation loop***	1400 Kc	6 & 7	Tune signal for max. with receiver tuning knob, then peak trimmers 6 & 7.
4.	1400 Kc	-	Radiation loop***	1400 Kc	7	With chassis assembled into cabinet, repeak antenna trimmer.

* A convenient point is the stator of the tuning capacitor.

** Close gang fully and set pointer to calibration mark at left hand side of dial background, then set to 1600 Kc by setting pointer at right hand calibration mark.

*** Connect output of signal generator to a 5" diameter, 3 turn loop and bring loop close enough to receiver loop to obtain output of 50 milliwatts (.40V) on output meter. Vary distance between loops to maintain this output during alignment. Minimum distance between loops should never be less than 12".

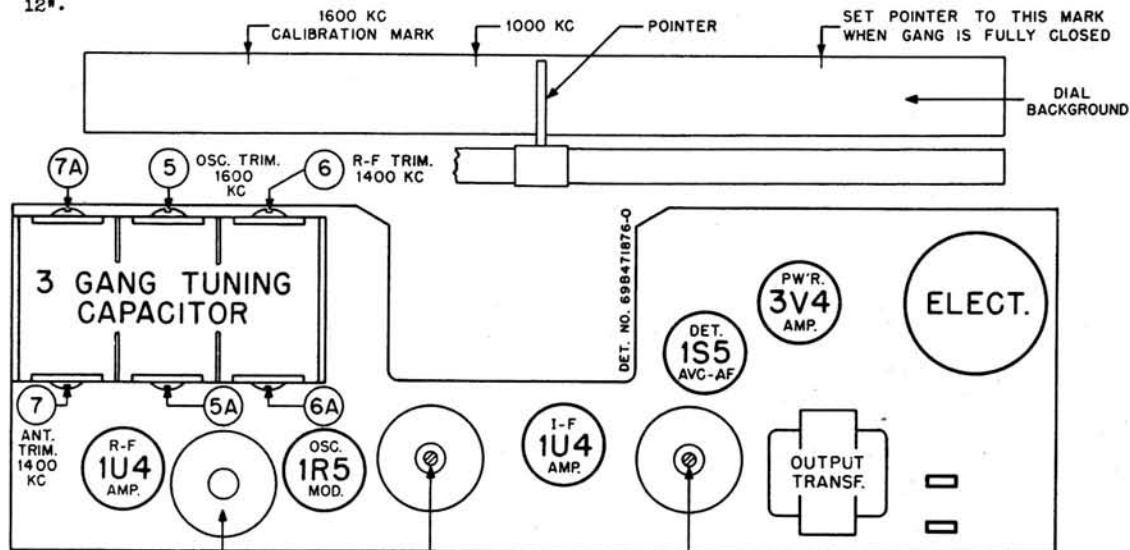

R-F COIL INDUCTANCE ADJUSTMENT (BOTTOM) (SEE INSTRUCTIONS FOR ADJUSTMENT)

I-F 455 KC
3 SEC. (BOTTOM)
4 PRI. (TOP)

DIODE 455 KC
1 SEC. (BOTTOM)
2 PRI. (TOP)

MANUAL OF 1948 MOST-OFTEN-NEEDED RADIO DIAGRAMS MOTOROLA INC.

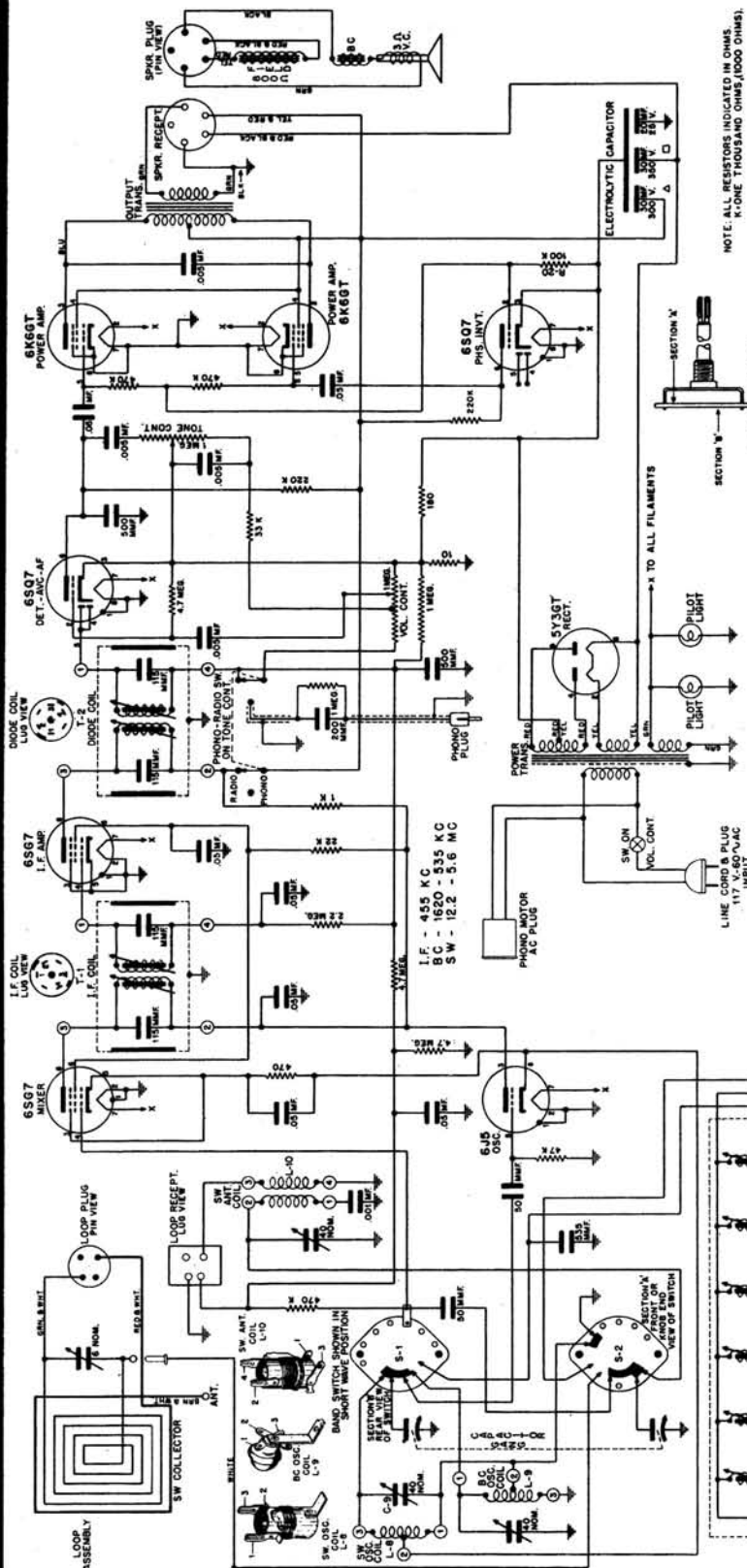

VOLUME CONTROL ON FULL.
VOLTAGE TOLERANCE $\pm 10\%$
RESISTANCE TOLERANCE $\pm 20\%$

BAND SWITCH IN B.C. POSITION.
PHONO RADIO SWITCH IN RADIO POSITION
* MEASUREMENTS MAY VARY DUE TO ELECTROLYTIC CAPACITOR IN CIRCUIT.

= RESISTANCE MEASUREMENTS.
= VOLTAGE MEASUREMENTS

NOTE: A VTVM. WAS USED TO MAKE MEASUREMENTS. IF A 20,000 OHM PER VOLT METER IS USED ALL GRID & AVC VOLTAGES WILL READ LOWER.
MEASUREMENTS ARE MADE FROM TUBE BASE PIN TERMINALS TO CHASSIS.

6S07
PHASE INV.

6S07
DET-AVC-AF

6S07
MIXER

6K6GT
PWR. AMP.

6K6GT
PWR. AMP.

6S07
I-F AMP.

6S07
I-F AMP.

6S07
I-F AMP.

6S07
I-F AMP.

6S07
I-F AMP.

6S07
I-F AMP.

6S07
I-F AMP.

6S07
I-F AMP.

6S07
I-F AMP.

PERMEABILITY TUNER PT-8

Motorola Model 85F21
Chassis HS-22
(Models 65F21, 85K21,
Chassis HS-26, HS-52,
are similar).

MANUAL OF 1948 MOST-OFTEN-NEEDED RADIO DIAGRAMS

Motorola

Model 85F21
Chassis HS-22

(Schematic on previous page)

ALIGNMENT

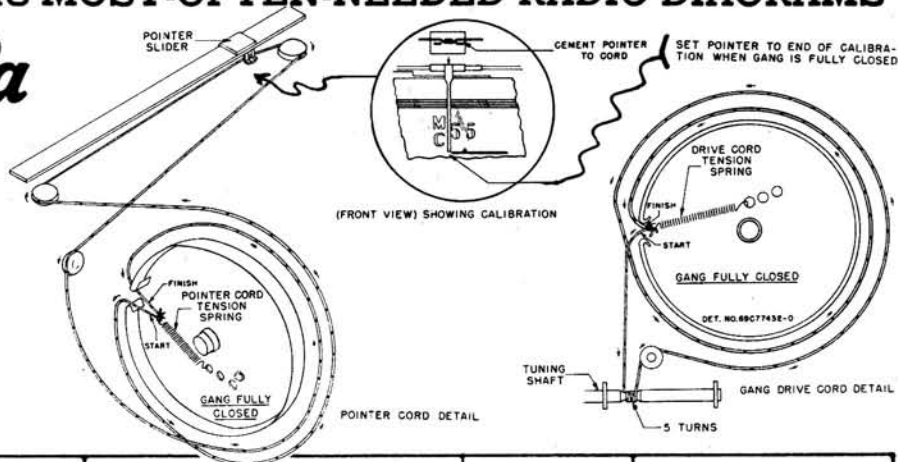

Step	Gang Setting	Band	Dummy	Generator Connected to	Generator Frequency	Trimmer or Core	Remarks
1	Fully opened	B. C	.1mf	Mixer grid & chassis	455 kc	1, 2, 3, & 4	Adjust I. F. & Diode trans. for maximum
2	Fully opened	B. C	-	Radiation loop*	1620 kc	5	Set oscillator to dial scale
3	1400 KC	B. C	-	Radiation loop*	1400 kc	6 †	Tune signal generator for max. on output meter, then peak trimmer.
4	12.2 MC	SW	50mmf	Short wave antenna terminal	12.2 Mc	7	Set osc. to dial scale.
5	11.5 MC	SW	50mmf	Short wave antenna terminal	11.5 Mc	8	Tune signal generator for max. on output meter, then peak trimmer.

† Repeat after chassis and loop are installed in cabinet.

* Connect output of signal generator to a 5" diameter, 3 turn loop. With volume on full, bring loop close enough to receiver until output of 50 milliwatts is obtained (.38V on output meter). Vary distance between generator and receiver loops to maintain this output during alignment. Minimum distance between loops should never be less than 12".

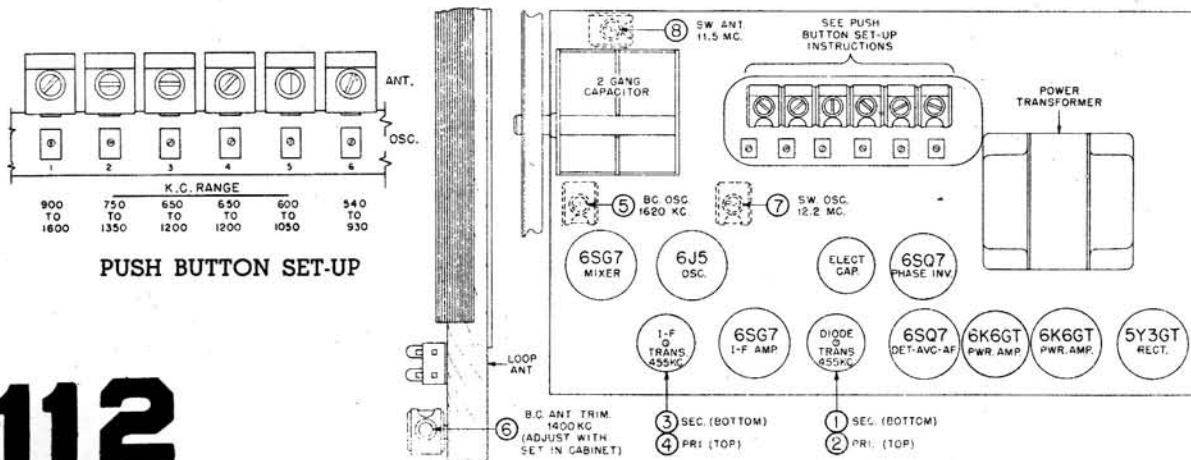

MANUAL OF 1948 MOST-OFTEN-NEEDED RADIO DIAGRAMS

Motorola Model CT6 for Chevrolet (Many other Motorola Auto Sets for other cars are similar in some respects).

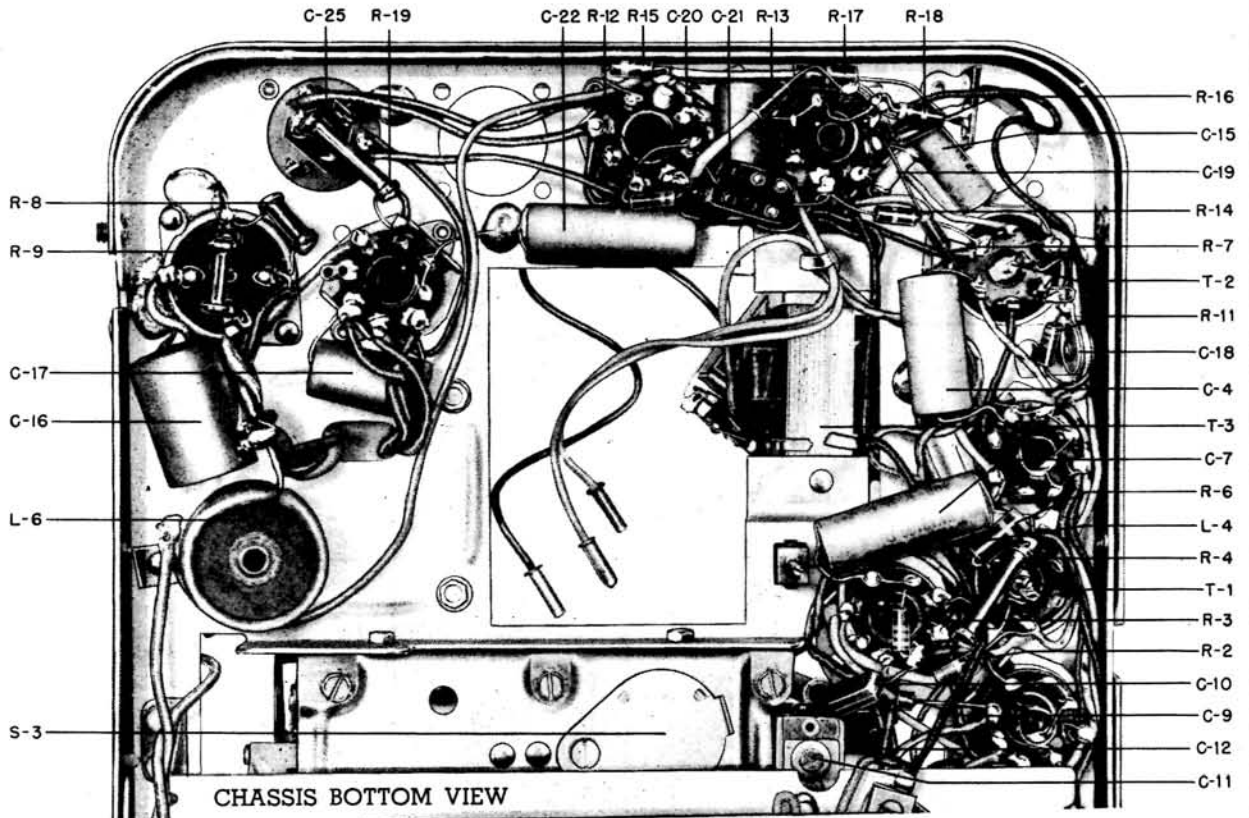

CHASSIS BOTTOM VIEW

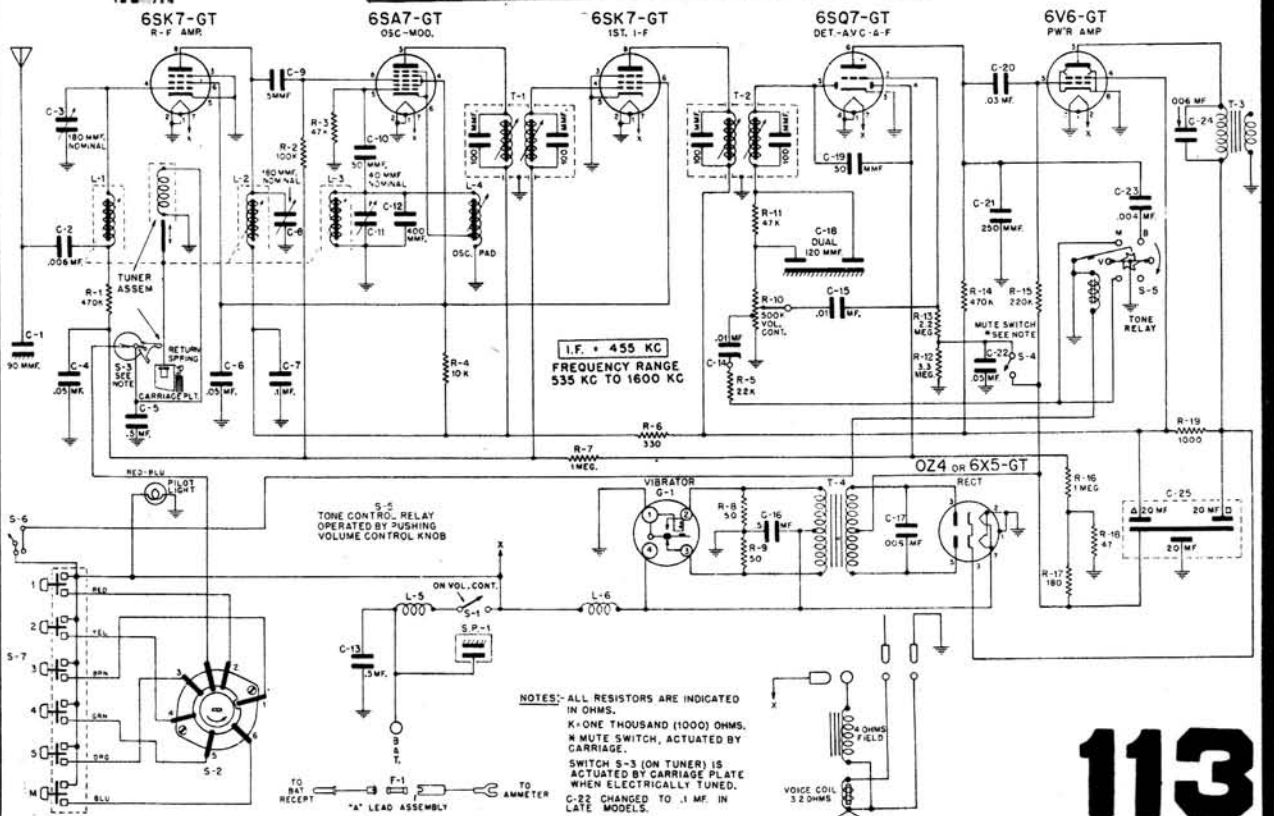

Motorola Auto Radio
Model CT6 for Chevrolet
Schematic on page 113.

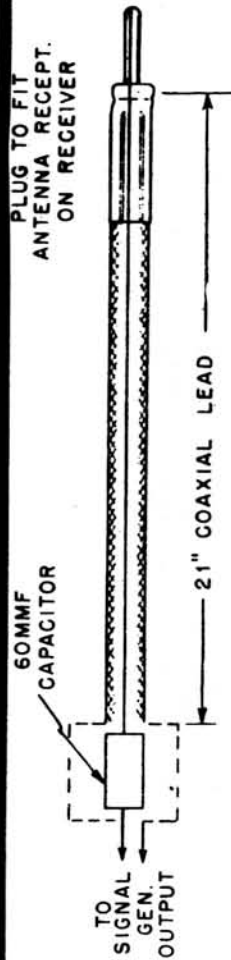

DUMMY ANTENNA CONSTRUCTION-DETAIL

STEP	TUNER POSITION SET TO	DUMMY ANTENNA	SIGNAL GENERATOR LEAD CONNECTED TO	SIG. GEN. SET AT	ADJUST FOR PEAK ON OUTPUT METER
1.	High frequency end (cores out)	.1 mfd. at Sig. Gen.	Osc. Mod grid (#5 pin)	455 Kc	#1 and 2 P & S in T-1 #3 and 4 P & S in T-2
2.	High frequency end, tuning shaft against stop. Cores should be set to project 1-1/8" from cans.*	60 mmf. at Sig. Gen. in series with 21" long coax lead	Antenna Receptacle	1600 Kc	#5 Osc. coil trimmer #6 R.F. coil trimmer #7 Ant. coil trimmer
3.	EXACTLY one full turn in from high frequency end. Use knob set screw as an indicator. Start measuring turn the moment tuner carriage starts moving inward.*	"	"	1425 Kc	#8 Osc. coil core #9 R.F. coil core #10 Ant. coil core
4.	EXACTLY four more full turns in (as indicated by knob setscrew)	"	"	Power turned Off.	#11 Osc. Pad. core for maximum noise

NOTE: If oscillator padder core adjustment is too far off, repeat alignment procedure, steps 2, 3, and 4. It may be necessary to repeat alignment more than once if padder adjustment has been indiscriminately tampered with.

5. Install assembled receiver in car and peak antenna trimmer (#7) to car antenna. Extend antenna to its full height. Tune set to a spot around 1400 kc that is free of stations, and adjust antenna trimmer (#7) for maximum noise.

* For greater accuracy in setting tuner to alignment frequencies, use gauge (Motorola Part No. 66A7682B)

MANUAL OF 1948 MOST-OFTEN-NEEDED RADIO DIAGRAMS

MOTOROLA Model CT6 for Chevrolet (See also pages 113, 114)

For alignment refer to chart on page 114, and trimmer location diagrams below. Use special tool, Motorola part No. 66A76278, for adjusting tuner cores. A small screwdriver will do for I.F. and R.F. alignment. Use dummy antenna as described on page 114. A low range output meter is required. Adjustment points shown below will be exposed after front and rear covers are removed. Allow receiver to warm up, press "M" button to place automatic tuner in manual tuning position. Volume control at maximum, tone control to voice position (high position).

Pointer and Drive Cord Replacement

Remove (1) the front cover, (2) the dial background, and (3) push-button assembly. Four screws hold it in position. Do not unsolder any wire leads, just lay the push-button assembly on top of the set. The pointer and drive cords are now fully exposed.

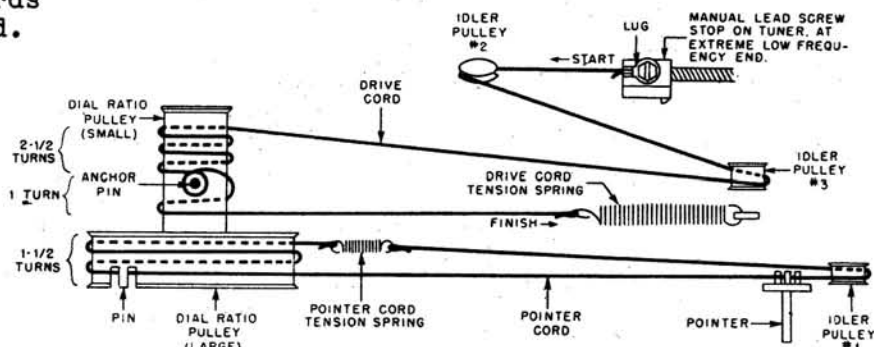
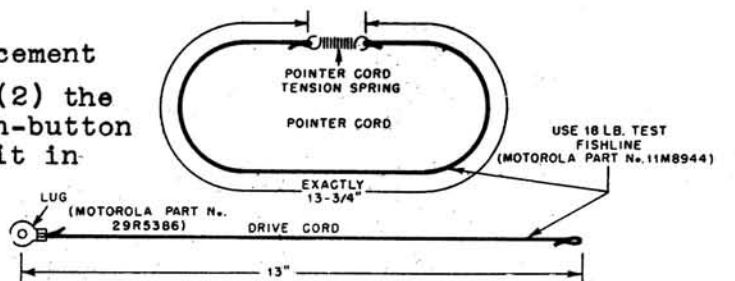

ANT. COIL TRIM.
1600 KC.

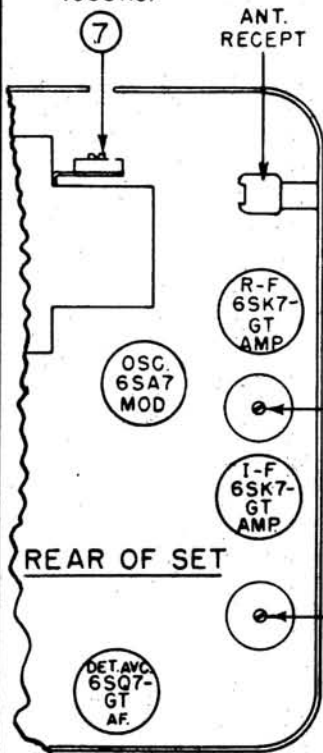

R-F COIL TRIMMER
1600 KC.

OSC. COIL TRIMMER
1600 KC.

(T-1)
I-F TRANS.
455 KC.

OSC. PAD.

(T-2)
DIODE TRANS
455 KC.

FRONT OF SET

R-F COIL CORE
1425 KC

ANT. COIL CORE
1425 KC.

OSC. COIL CORE
1425 KC.

RIGHT SIDE OF SET

MANUAL OF 1948 MOST-OFTEN-NEEDED RADIO DIAGRAMS

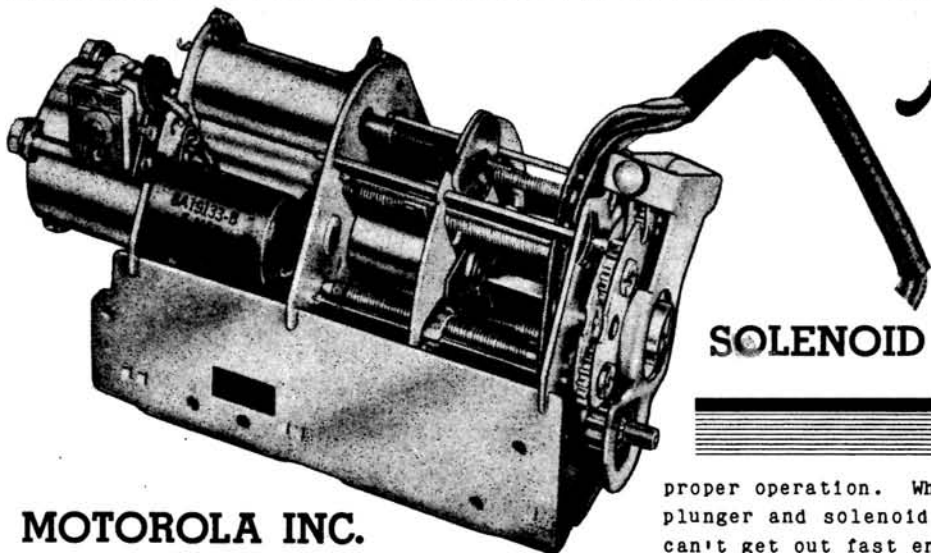

Motorola

SOLENOID TUNER ST-56

MOTOROLA INC.

Solenoid Tuners ST-56 (ST-56 - CR6, ST-56 - FD6 etc.,) are used in 1946 and 1947 Motorola automatic tuning specific auto receivers.

Fundamentally, all ST-56 tuners are the same except for the manual tuning shaft, dial cord pulleys and pushbutton switch lead lengths. These variations are brought about by mechanical differences between the specific receivers in which this tuner is used. The receiver model number is included in the tuner model number to identify which specific receiver the tuner will fit, i.e., ST-56-CR7, ST-56-BK8 etc.

This is a 3 gang permeability type tuner operated by a solenoid. Five pre-set and one manual tuning positions are provided. The frequency range is 535 to 1600 kc. The pre-set positions can be set to any frequency within this range.

The tuner is designed to operate satisfactorily with 4-1/2 to 7.3 volts input. Before attempting any service work on a tuner that operates too slowly or one that doesn't operate at all, check the battery voltage directly at the receiver spark plate. Normally, this voltage is 6.3 volts. At the moment any pushbutton is pressed, the voltage at the spark plate should not drop to less than 4-1/2 volts. If the voltage is less than 4-1/2, it is an indication of poor wiring between the car battery and receiver or a defective car battery.

This tuner depends on "dash-pot" action between the plunger and the solenoid for

proper operation. When the fit between the plunger and solenoid is too tight, the air can't get out fast enough. The result is a slow or sluggish operating tuner. All late production tuners have an adjustable air release in the solenoid end plate. Early production tuners that do not have this adjustable air release and operate sluggishly, due to dash-pot action, should have the solenoid end plate replaced with an end plate having the adjustable air release. Order part number 1X76556.

The tuner solenoid coil must be in a horizontal or near horizontal position or the tuner will not operate properly. If it is operated with the coil in a vertical position, the solenoid and carriage return spring may not be strong enough to operate tuner.

THEORY OF OPERATION

NOTE: Throughout this paragraph, it is suggested that constant reference be made to Figure 1.

When any push-button is pressed, current flows through the solenoid coil, causing the plunger to pull into the coil. Near the end of the plunger travel, through a ratchet mechanism inside the plunger, the selector switch shaft is rotated 60°, moving the selector switch and stop plate to their new position.

An instant later, the solenoid switch is opened breaking solenoid current and the carriage return spring then pulls the plunger out, closing the solenoid switch again. If the selector switch is now resting at the position selected by the push-button (cut away section of selector switch resting in front of contact selected by push-button), the solenoid plunger will continue to be pulled out until the stop plate is resting on the selected lead screw stop. In the event the selector switch

MANUAL OF 1948 MOST-OFTEN-NEEDED RADIO DIAGRAMS

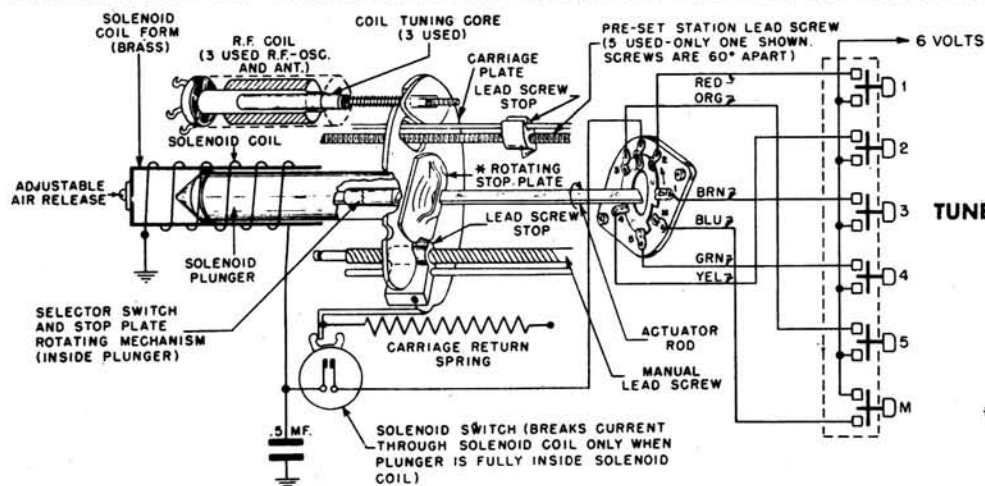

FIGURE 1.

TUNER FUNCTIONAL DETAIL

* SELECTOR SWITCH AND STOP PLATE ROTATE 60° (1/6 TURN) EACH TIME SOLENOID IS ACTUATED.

is not resting in the position selected by the push button when the solenoid plunger is on its return trip, the moment the plunger moves out far enough to actuate the solenoid switch, current will again flow through solenoid causing the plunger to be pulled in again. The plungers inward motion again rotates the stop plate and selector switch through another 60°. This last operation is repeated automatically until the selector switch comes to rest at the position selected by the push-button, at which time the solenoid circuit is opened and the plunger moves out until the stop plate is resting on the selected lead screw stop. The stops are adjusted to the desired positions during the station setting up procedure, through the set-up gear train assembly.

Refer to Figure 2 for mechanics behind station setting-up mechanism detail.

When the button on which a station is to be set up is first pressed, the tuner operates and the stop plate comes to rest against the selected lead screw stop. The pressure of the stop plate against the lead screw stop moves the lead screw forward until its shoulder rests against the tuner and plate. The square end of the lead screw does not engage in the square hole of the set-up gear until the set-up button is pushed in or the station set-up knob is turned (whichever is applicable). A latch on one end of the detent lever engages the gear lever, holding the set-up gear train in contact with the selected lead screw. Now the selected lead screw stop can be moved on its lead screw by turning the manual tuning shaft. None of the other lead screws turn because the stop plate is not resting against them. After the button is set up, pressing any other button will unlatch the gear lever and disengage the lead screw from the set-up gear. See Figure 2.

Since the coil tuning iron cores are attached to the carriage plate and move in unison with the plunger, the point at which they are brought to a stop (by means of the lead screw stop) determines the frequency to which the coils are tuned.

Dash-pot action between the plunger and the solenoid determines the tuner operating speed. The rate at which air is allowed to enter or escape through the adjustable air release determines the speed of the plunger. See Figure 1.

TO REMOVE TUNER FROM CHASSIS

Should it become necessary to remove the solenoid tuner from the receiver chassis, proceed as follows:

1. Remove the covers from the set, completely exposing the chassis.
2. Mark all leads connecting tuner to receiver.
3. Disconnect all leads connecting tuner to receiver. Do not unsolder leads from the tuner selector switch; unsolder them at the push-switch. The .5 mf paper capacitor need not be removed.
4. The tuner is held to the chassis by self-tapping screws driven into the sides of the tuner. Do not remove any other screws.

The speed at which the tuner operates is governed by dash-pot action of the solenoid plunger within the closed solenoid coil form. The rate at which air is allowed to enter or escape determines the speed of the plunger.

(Motorola Tuner ST-56)

MANUAL OF 1948 MOST-OFTEN-NEEDED RADIO DIAGRAMS

AIR RELEASE ADJUSTMENT

An adjustable air release is provided on all late production tuners. See Fig. 3. To adjust, loosen the screw and move the eccentric washer which covers the air release hole to expose or cover more of the air release hole

as required. Early production tuners did not have a solenoid end plate with an adjustable air release. If such a tuner is slow or sluggish because of too much "dash-pot" action, replace the solenoid end plate with the adjustable air release type. Order part number 1X76556.

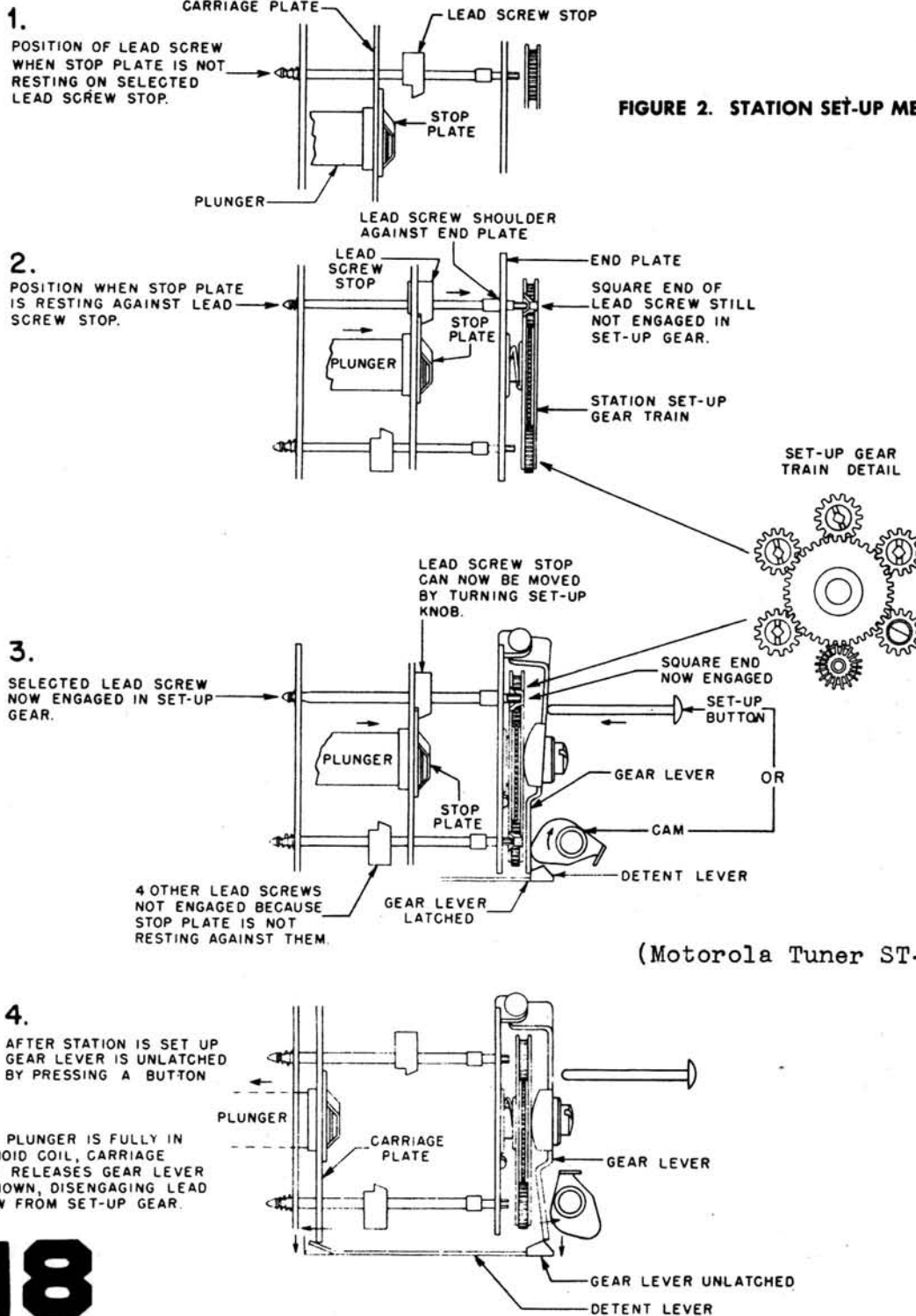

(Motorola Tuner ST-56)

MANUAL OF 1948 MOST-OFTEN-NEEDED RADIO DIAGRAMS

END VIEW OF TUNER

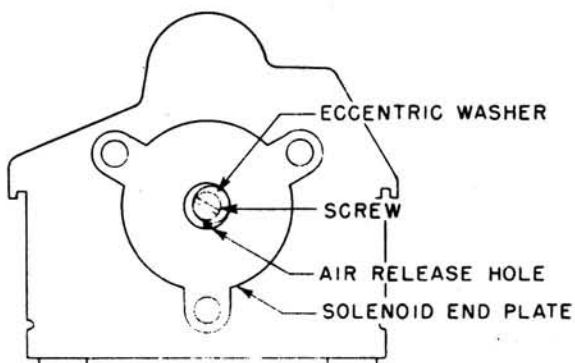

FIGURE 3. AIR RELEASE ADJUSTMENT

1. If tuner operates too slowly, open the air release hole. Open it only far enough to secure reliable operation. Too little "dash-pot" action (air release open too much) may cause the plunger to hammer and sometimes even to make the tuner operate continuously due to the selector switch rotor being turned so rapidly as to overshoot its contacts.
2. If the tuner operates too rapidly increase dash-pot action by closing the air release hole slightly. Close it only enough to eliminate hammering.

PLUNGER RATCHET ADJUSTMENT

The plunger ratchet mechanism in Figure 4. This mechanism rotates the actuator rod which, in turn, rotates the carriage stop plate and the selector switch 60° for each inward motion of the plunger.

If this adjustment is incorrect, tuner may operate continuously once current is applied.

Correct ratchet adjustment is indicated when $1/64$ to $1/32$ " clearance is observed between selector switch contacts and the selector switch rotor as shown in Figure 5. Slowly work the plunger by hand and observe clearance at each contact position. If the average clearance is not $1/64$ to $1/32$ ", correction can be made by loosening ratchet adjustment setscrew and turning actuator rod by hand until correct clearance is observed.

Before ratchet adjustment setscrew is finally tightened, push fixed ratchet $1/32$ " back into plunger. This increases spring tension against rotating ratchet, thus insuring more positive operation.

FIGURE 4. PLUNGER RATCHET MECHANISM

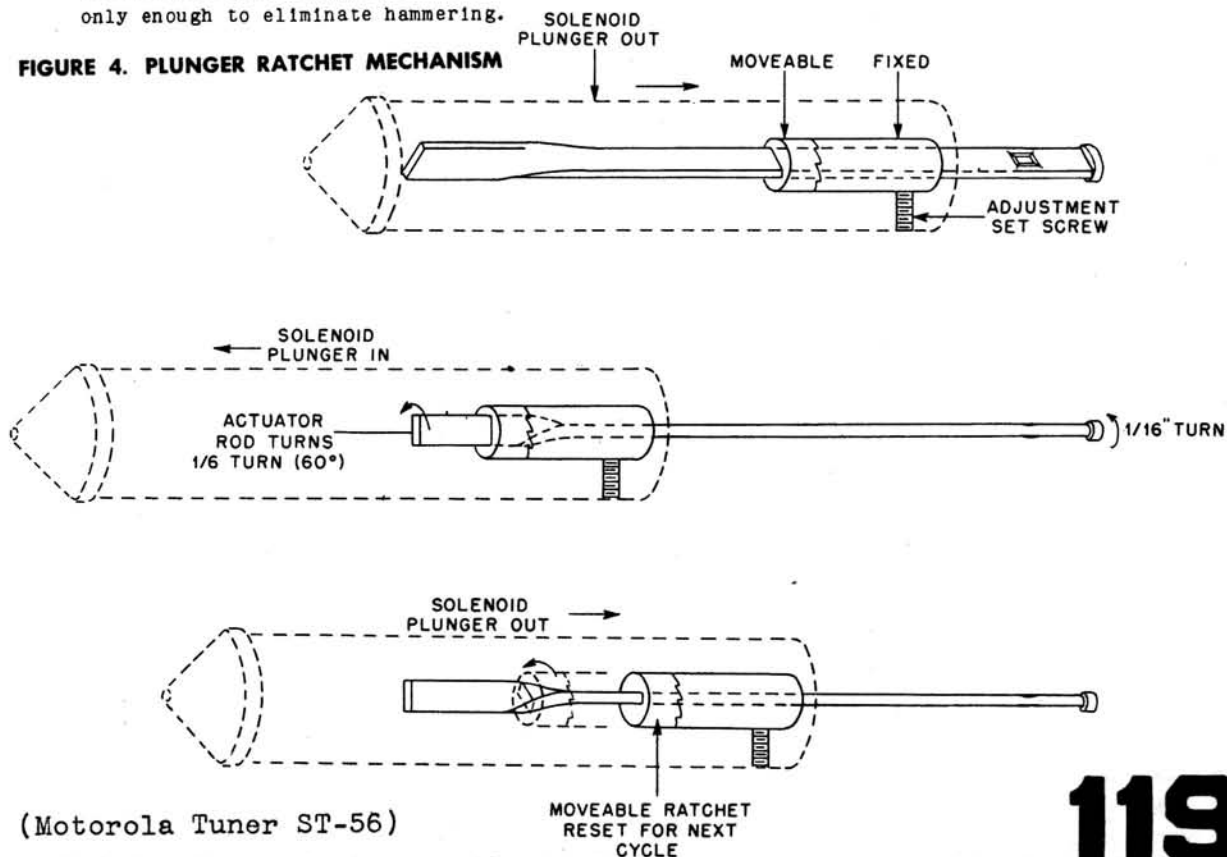

(Motorola Tuner ST-56)

MANUAL OF 1948 MOST-OFTEN-NEEDED RADIO DIAGRAMS

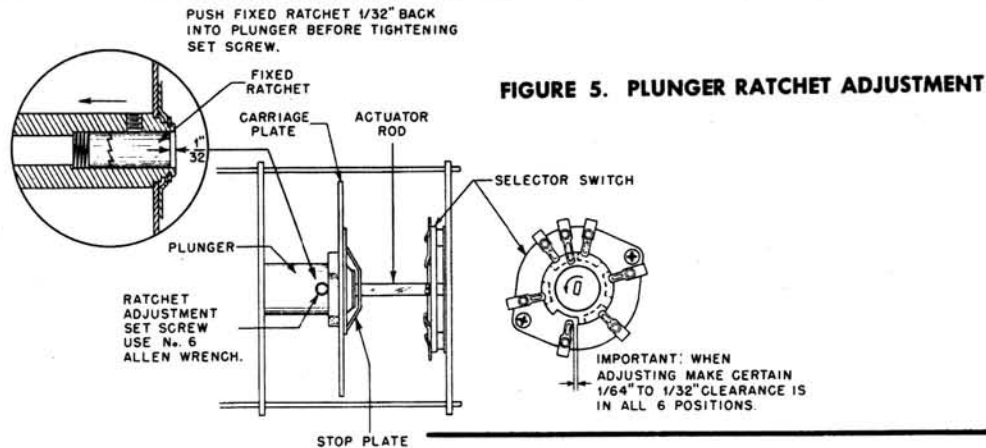

(Motorola Tuner ST-56)

SOLENOID SWITCH TRIP ADJUSTMENT

The solenoid switch tripping mechanism should be adjusted as shown in Figure 6.

If the solenoid switch is tripped too early, the ratchet mechanism may fail to operate; if it trips too late, the plunger may hammer violently or should the solenoid switch fail to trip, the plunger would be held within the solenoid.

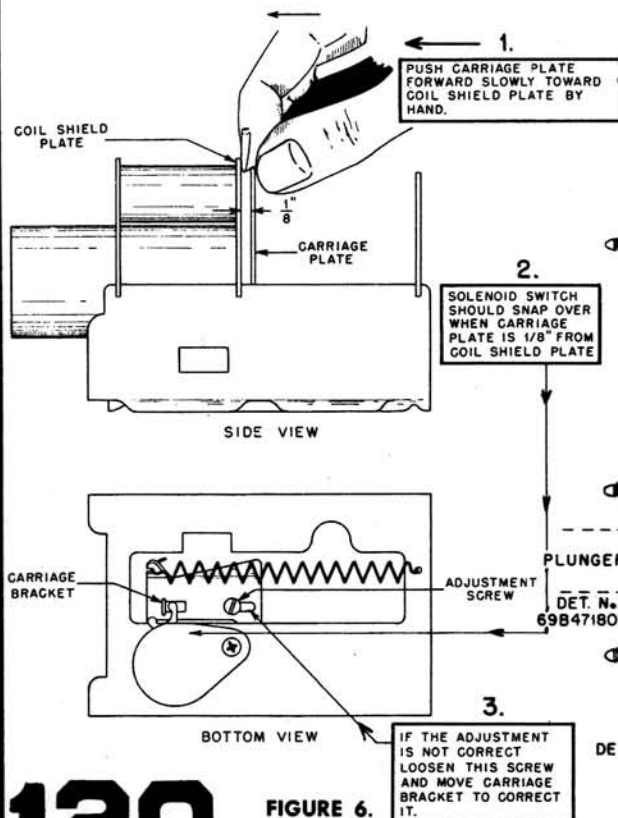

FIGURE 6. SOLENOID SWITCH ADJUSTMENT

ADJUSTMENT OF GEAR LEVER LATCH

The gear lever latch holds the station set-up gear train in position while setting up stations. Failure of the latch to engage properly when the set-up button is pushed in or the station set-up knob is turned (whichever is applicable) would result in the inability to set up pre-set stations. Failure of the latch to disengage after station is set up would result in faulty automatic tuning because the lead screws might not seat themselves properly against the tuner end plate. Figure 7 above shows the latch detail and adjustment.

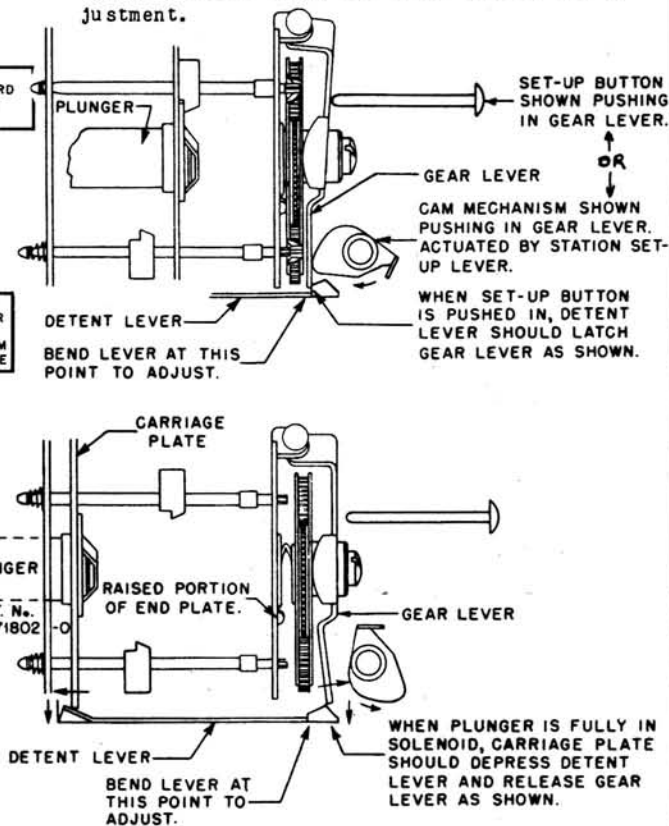

FIGURE 7. GEAR LEVER LATCH ADJUSTMENT

MANUAL OF 1948 MOST-OFTEN-NEEDED RADIO DIAGRAMS

SERVICE NOTES

FAILURE OF SOME LEAD SCREW TO ENGAGE IN SET-UP GEARS

If some of the lead screws fail to engage in the set-up gears during station setting up procedure, check the gear lever to see if it is bent. When the set-up button is pushed in and the gear lever latches on the detent lever, the set-up gear train should be parallel with the tuner end plate and the bottom of the gear train should be resting on the raised portions of the tuner end plate.

LUBRICATION

Should lubrication ever be required, it is recommended that a very fine grease, commercially called Lubriplate, or its equivalent, be used.

Remove all old and sticky lubricant with a solvent such as carbon tetrachloride and then, very sparingly, lubricate only the following points:

1. Carriage guide rods.
2. Actuator rod.
3. Manual lead screw.

Do not lubricate or permit lubricant to get on Selector Switch contacts. The friction drag is required for proper operation of tuner.

LEAD DRESSING

Make sure that the selector switch and solenoid coil leads are dressed so that carriage plate does not rub against them. Leads rubbing against the carriage plate may cause the tuner to stick, especially at the high frequency end.

REPLACEMENT OF SOLENOID COIL OR SOLENOID PLUNGER

Should replacement of the solenoid coil or solenoid plunger be required, it will be necessary to replace the entire tuner. A close fit between solenoid plunger and solenoid coil form is required; a proper match can only be secured at the factory. When service of this kind is required, return the tuner to the factory for exchange.

TO REPLACE ANT. R.F., OR OSC. COILS

IMPORTANT: When ordering replacement coils, order by part number and also specify the color coding (paint dots) on old coil. THE REPLACEMENT COIL SHOULD CARRY THE SAME

COLOR CODING AS THE ORIGINAL OR THE TUNER WILL NOT TRACK PROPERLY.

1. If coil is not readily accessible remove the tuner from the chassis as outlined under "TO REMOVE TUNER FROM CHASSIS."
2. Unsolder the two lugs holding the coil to the tuner plate.
3. Carefully remove the old coil. Save the thin paper washer that is found at the base of the coil.
4. Slip the paper washer over the replacement coil and slip coil into shield can.
5. Orient coil so its lugs are in same position as before and resolder to tuner plate.
6. Reassemble tuner and install in receiver.
7. Realign ANT., R.F. and OSC. stages per instructions found in the receiver service manual.

TO REPLACE ANT. R.F. OR OSC COIL TUNING CORES

1. The core which tunes the top coil is readily accessible and presents no replacement problem. To reach the two bottom coil tuning cores, remove the tuner from the chassis base as outlined under "TO REMOVE TUNER FROM CHASSIS."
2. Remove the carriage return spring.
3. Move the carriage plate back as far as it can go. The tuning cores can now be screwed "out" or "in" by grasping the portion that sticks out the back of the coil. When installing a new core, make sure that the insulating washer and adjustment clip are replaced properly. The insulating washer goes on the core side; the core adjustment clip has an ear on it and this ear must fit into a hole in the bakelite insulator on the carriage plate. Refer to Figure 8.
4. Replace the carriage return spring.
5. Install tuner in receiver.
6. Realign ANT., R.F. and OSC. stages following the instructions found in the receiver service manual.

(Motorola Tuner ST-56)

MANUAL OF 1948 MOST-OFTEN-NEEDED RADIO DIAGRAMS

VOLTAGE & RESISTANCE MEASUREMENTS FROM SOCKET TERMINALS TO FLOATING GROUND

VOLTAGE

TUBE	WITH SLIDE SWITCH IN ELECTRIC POSITION							
	1	2	3	4	5	6	7	8
1R5	2.8	95	48	**	2.8	*1.8	4.2	
1U4	0	95	95	*1.8	0	0	1.4	
1S5	2.8	0	*2	*20	*50	*1	1.4	
3V4	4.2	95	95	7	5.6	0	7	
OY4	0	0	+DC	117AC	117AC	0	120	120

RESISTANCE

TUBE	WITH SLIDE SWITCH IN BATTERY POSITION							
	1	2	3	4	5	6	7	8
1R5	3.0	90	48	**	3.0	*1.8	4.5	
1U4	0	90	90	*1.8	0	0	1.5	
1S5	3.0	0	*2	*20	*50	*1	1.5	
3V4	4.5	90	90	0	6.0	0	7.5	
OY4	0	0	0	0	0	0	0	0

All voltage measurements are made with a line voltage of 117V AC or a battery having 90 VB and 7.5 VA; with no signal using a 1000 ohm. per volt. voltmeter and are +DC unless otherwise indicated.

* Measured with a vacuum tube voltmeter.

** The oscillator voltage measured with a vacuum tube voltmeter from the oscillator grid to floating ground will vary from approx. -6V with the variable condenser closed to -12V with the condenser open. The true oscillator voltage measured from the grid to the negative filament lug should be from -10 to -20V.

* The resistance reading at this point is the leakage across the electrolytic condenser and will vary with different condensers and different ohmeters. With the negative lead of the ohmeter to floating ground, the reading may vary anywhere from 50K to 1M depending on the type meter used.

** 22K higher than the electrolytic condensers leakage

K equals 100 ohms
M equals 1 megohm

FREQUENCY RANGE
Broadcast 540-1600 kc
IF 455 kc

ARVIN Model 140P
Chassis RE-209
Noblitt-Sparks In.

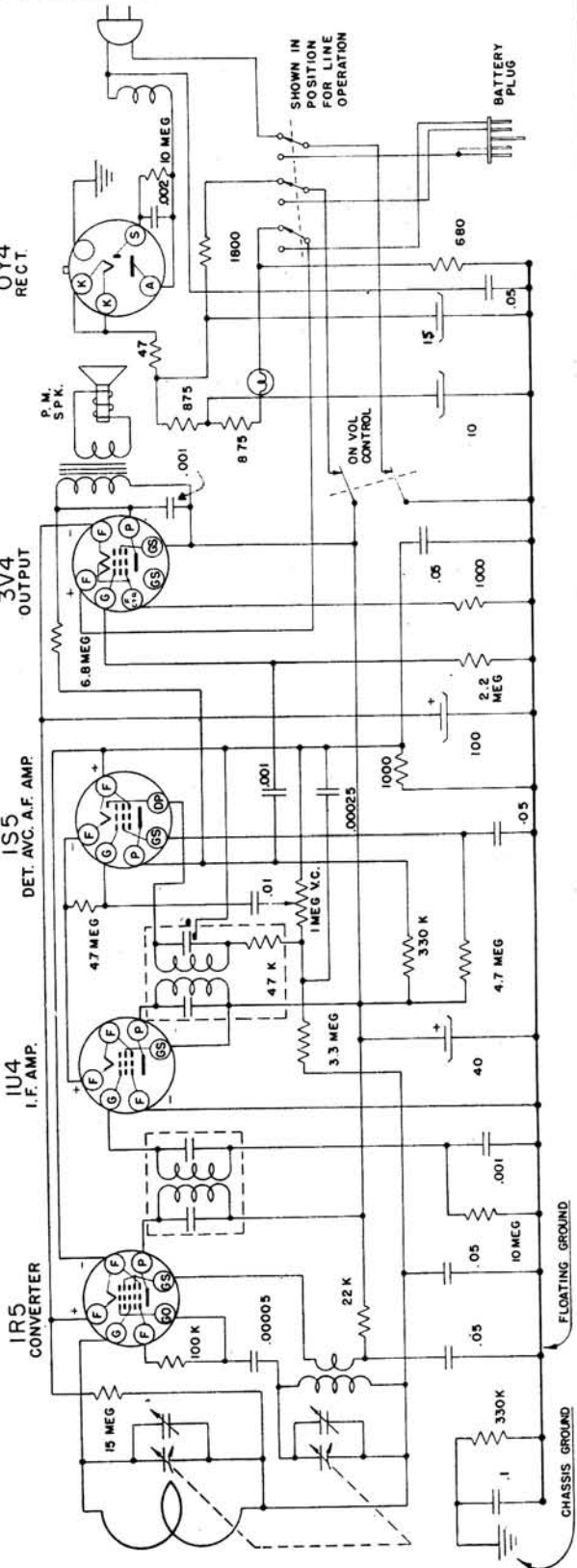
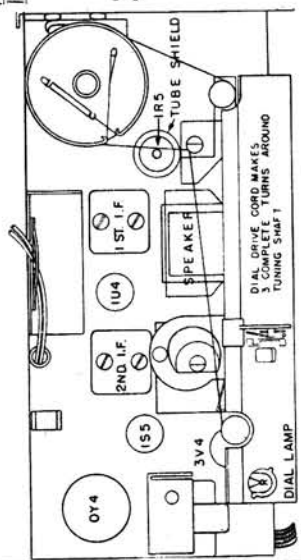

MANUAL OF 1948 MOST-OFTEN-NEEDED RADIO DIAGRAMS

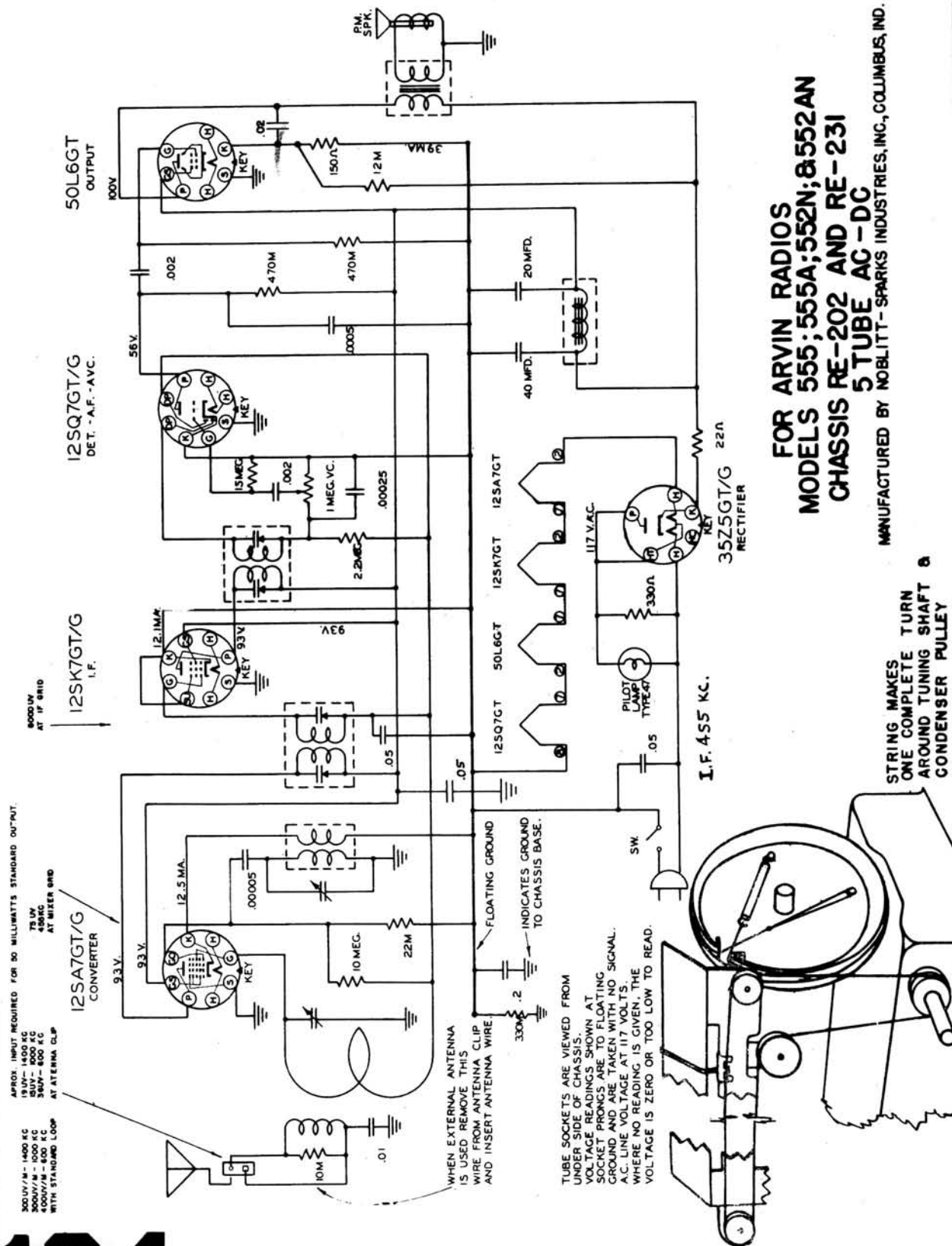

MANUAL OF 1948 MOST-OFTEN-NEEDED RADIO DIAGRAMS

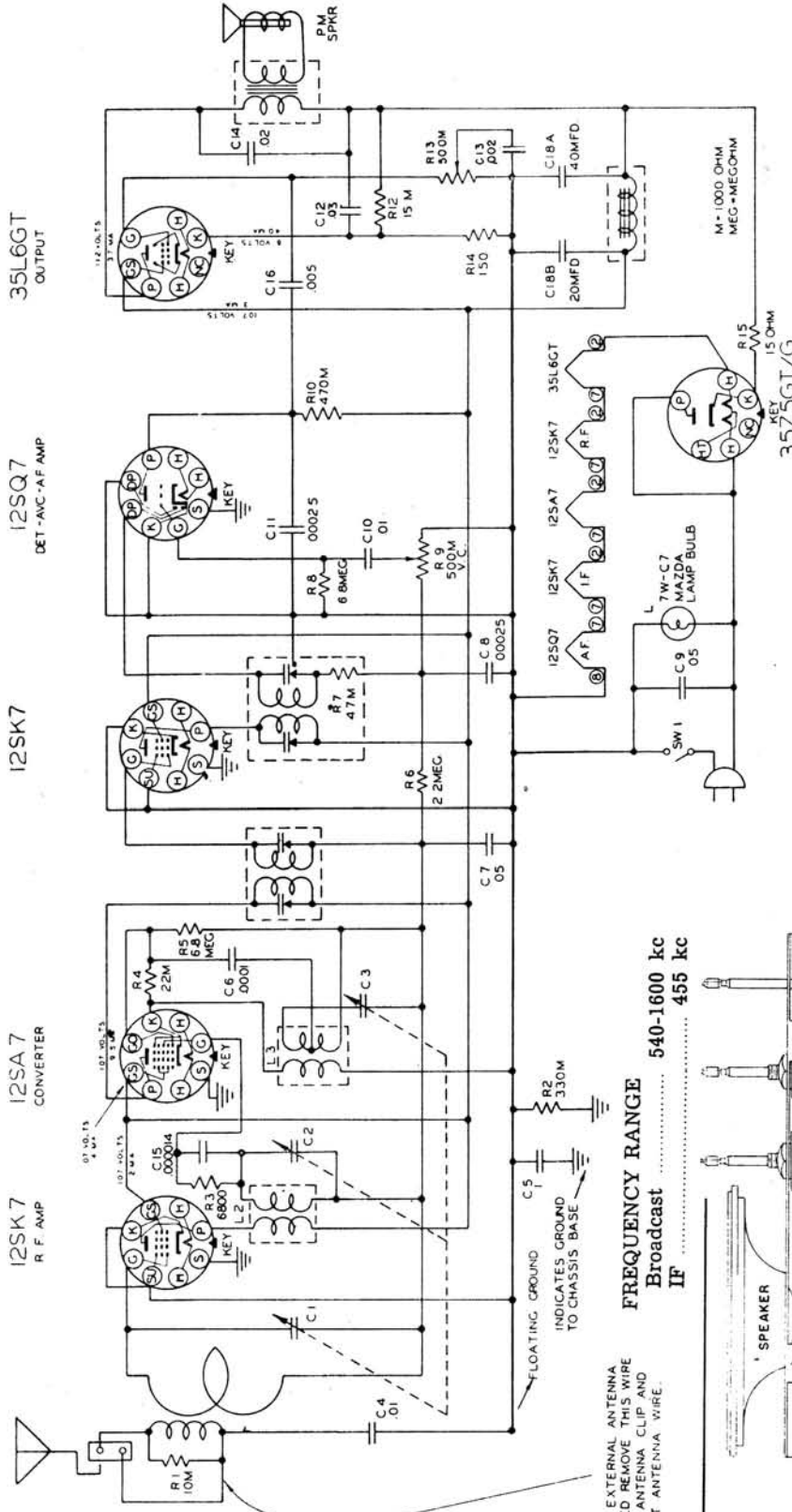

TUBE SOCKETS ARE VIEWED FROM UNDER SIDE OF CHASSIS. VOLTAGE READINGS ARE TO FLOATING GROUND AND ARE TAKEN WITH NO SIGNAL.

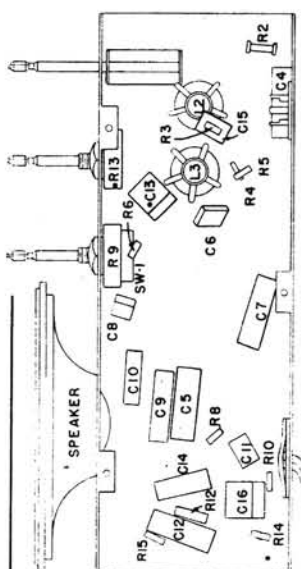

ARVIN RADIO MODEL 6640
CHASSIS RE-206-2, 6 TUBE AC-DC

MANUFACTURED BY NOBLITT - SPARKS INDUSTRIES, INC., COLUMBUS, IND.

MANUAL OF 1948 MOST-OFTEN-NEEDED RADIO DIAGRAMS

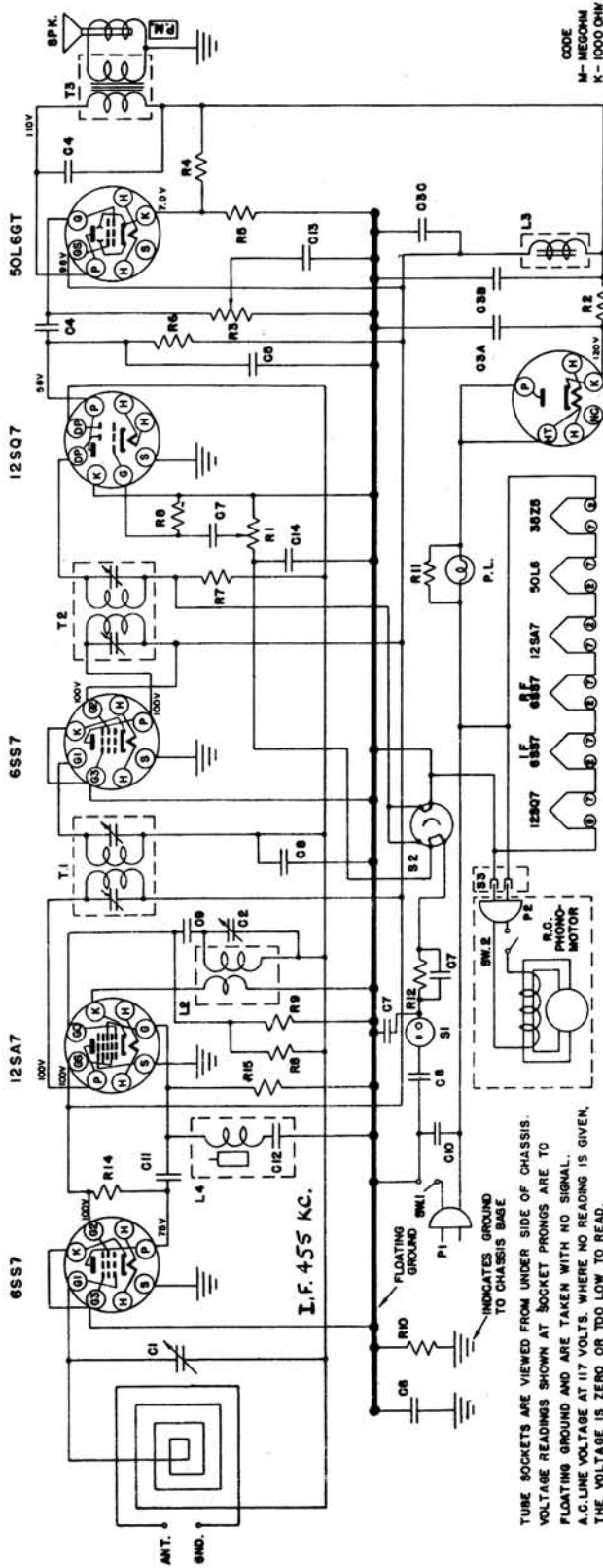

REF. NO.	PART NO.	DESCRIPTION
R1	C19582	Volume Control - 1 meg.
R2	C20060-150	Tone Control & Switch Resistor, 15 ohm
R3	C1946	Resistor, 12,000 ohm - 1 W.
R4	C20070-123	Resistor, 150 ohm
R5	C20060-151	Resistor, 150 ohm
R6	C20060-174	Resistor, .47 meg.
R7	C20060-223	Resistor, 2.2 meg.
R8	C20060-186	Resistor, 15 meg., 1/4 W.
R9	C20060-253	Resistor, 22,000 ohm
R10	C20060-334	Resistor, 330,000 ohm
R11	C20060-331	Resistor, 330 ohm
R12	C20060-224	Resistor, .22 meg.
R13	C20060-105	Resistor, 1 megohm
R14	C20060-222	Resistor, 2200 ohm, 1/4 W.
R15	C20060-104	Resistor, 100,000 ohm, 1/4 W.
C1	C19584	Var. Condenser, 2 gang
C2	A19780	Elect. Cond., 40 uf, 150 V.
C3	C20065-503	Elect. Cond., 20 uf, 150 V.
C4	C20065-501	Elect. Cond., 10 uf, 150 V.
C5	C20058-103	Condenser, Paper, .002 uf, 400 V.
C6	A19765	Condenser, Paper, .002 uf, 400 V.
C7	C20068-202	Condenser, .05 uf, 200 V.
C8	C20057-503	Condenser, Mic., .00005 uf, 500 V.
C9	C20065-500	Condenser, .05 uf, 400 V.
C10	C20068-503	Condenser, .05 uf, 400 V.
C11	A21040	Condenser, .00063 uf, 500 V.
C12	C20068-502	Condenser, .005 uf, 400 V.
C13	C20065-251	Condenser, .0025 uf, 600 V.
C14	A819943-1	Ant. Loop Assy.
L1	AC19586-1	Osc. Coil
L2	AC21073-1	Checke, Iron Core
L3		

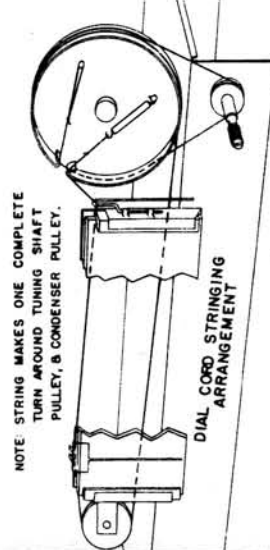
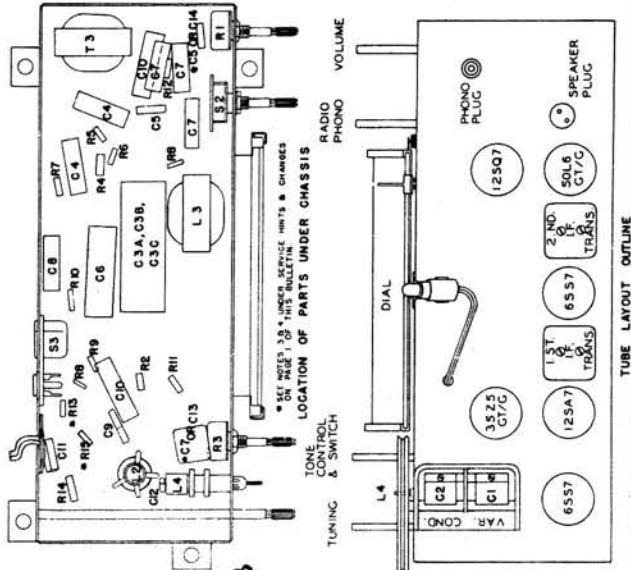

ARVIN Model 665
Chassis RE-229
Moblitt-Sparks

MANUAL OF 1948 MOST-OFTEN-NEEDED RADIO DIAGRAMS

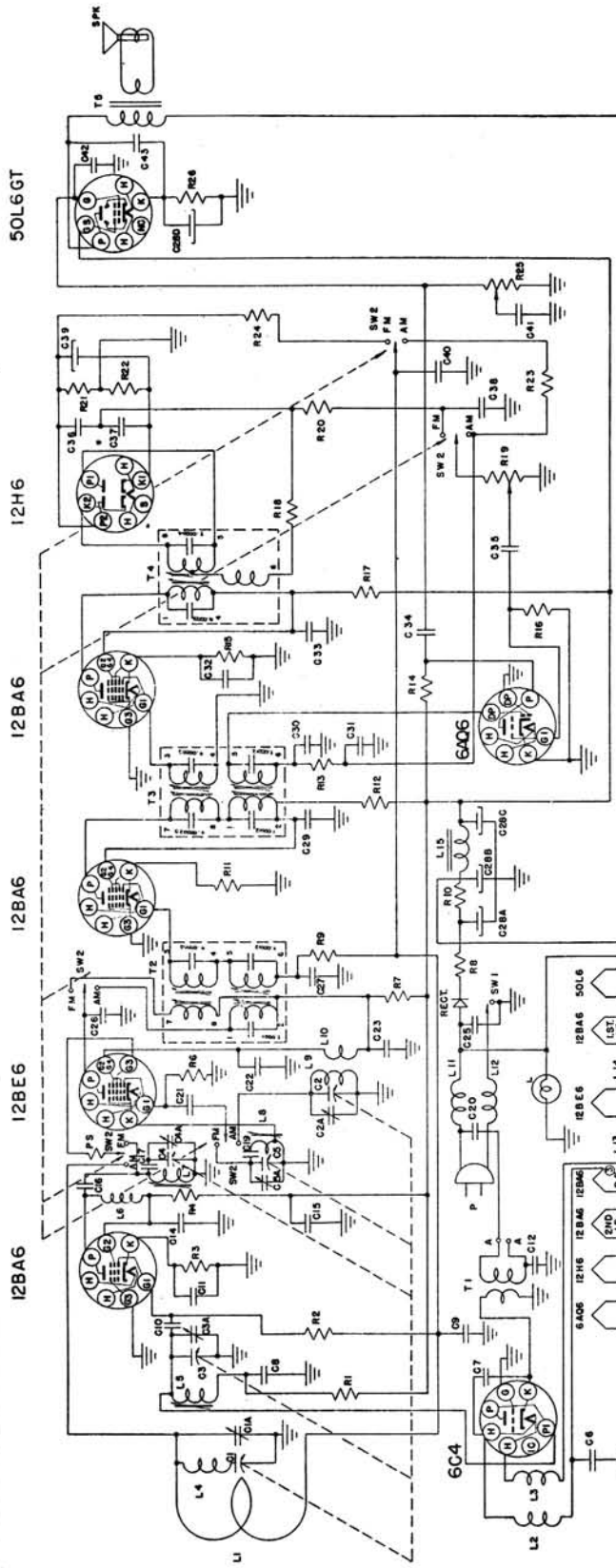

DESCRIPTION	PART NO.	DESCRIPTION
540-1600 KC	R1-12-17	Resistor, 1000 ohm, 1/4 W
455 KC	R2-24	Resistor, 1 megohm, 1/4 W
88-108 MC	R3-11-15	Resistor, 68 ohm, 1/4 W
10.7 MC	R4-7	Resistor, 330ohm, 1/4 W
	R5	Resistor, 10 ohm, 1/4 W
	R6-13-20	Resistor, 22,000 ohm, 1/4 W
	R8	Resistor, 22 ohm, 1/4 W
	R9	Resistor, 100,000 ohm, 1/4 W
	R10	Resistor, 100 ohm, 1 W
	R14	Resistor, 300,000 ohm, 1/4 W
	R16	Resistor, 68 megohm, 1/4 W
	R18	Resistor, 100 ohm, 1/4 W
	R-19	Volume Control, 1 megohm
	R21-22	Resistor, 6800 ohm, 1/4 W
	R23	Resistor, 2.2 megohm, 1/4 W
	R25	Tone Control and Switch, 500,000
	R26	Resistor, 220 ohm, 1/4 W
	C3A-4A	A21440 Trimmer Capacitor, 1.6-18 uuf.
	C5A	Compression Type Glass Compressor Capacitor, 1-8 uuf.
	C5A	A21439 Trimmer Capacitor, 1-8 uuf.
	C6-11-18-24	C20204-500 Capacitor, .00005 uf, 500V, Ceramic
	C7-20-30-31	C20204-101 Capacitor, .0001 uf, 500V, Ceramic
	C8-10	C20226-501 Capacitor, .0005 uf, 350V, Ceramic
	C9-12-13-14-22	C20226-102 Capacitor, .001 uf, 350V, Ceramic
	C15-23-27-29-32-33	C20226-502 Capacitor, .005 uf, 350V, Ceramic
	C16	C20204-100 Capacitor, .00001 uf, 500V, Ceramic
	C17	C20206-201 Capacitor, .0002 uf, 500V, Mica
	C19	C20205-2 Capacitor, .0001 uf, 500V, Ceramic
	C21	C20204-270 Capacitor, .000027 uf, 500V, Ceramic
	C25-34	C20068-503 Capacitor, .05 uf, 400 V, P. T.
	C26	C20205-3 Capacitor, .00002 uf, 500 V, Ceramic
	C28,A,B,C,D	A21402 Capacitor, Electrolytic, 40-40-80 uf, 150V, 20 uf, 25V
	C35	C20068-103 Capacitor, .01 uf, 400V, P. T.
	C36-37	C20205-5 Capacitor, .00005 uf, 500V, Ceramic 10% N750
	C38	C20203-202 Capacitor, .002 uf, 350V, Ceramic
	C39	A21403 Capacitor, Electrolytic, 8 uf, 50V
	C40	C20067-503 Capacitor, .05 uf, 200V, P. T.
	C41	C20067-502 Capacitor, .005 uf, 200V, P. T.
	C42	C20065-251 Capacitor, .00025 uf, 500V, Mica
	C43	C20069-502 Capacitor, .005 uf, 600V, P. T.

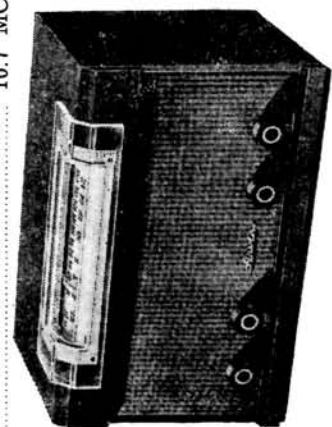

ARVIN RADIO — MODEL 182TFM CHASSIS RE — 237
 MANUFACTURED BY NOBLITT - SPARKS INDUSTRIES, INC., COLUMBUS, IND.

MANUAL OF 1948 MOST-OFTEN-NEEDED RADIO DIAGRAMS

ARVIN Chassis RE-228

Models 150-TC, 151-TC

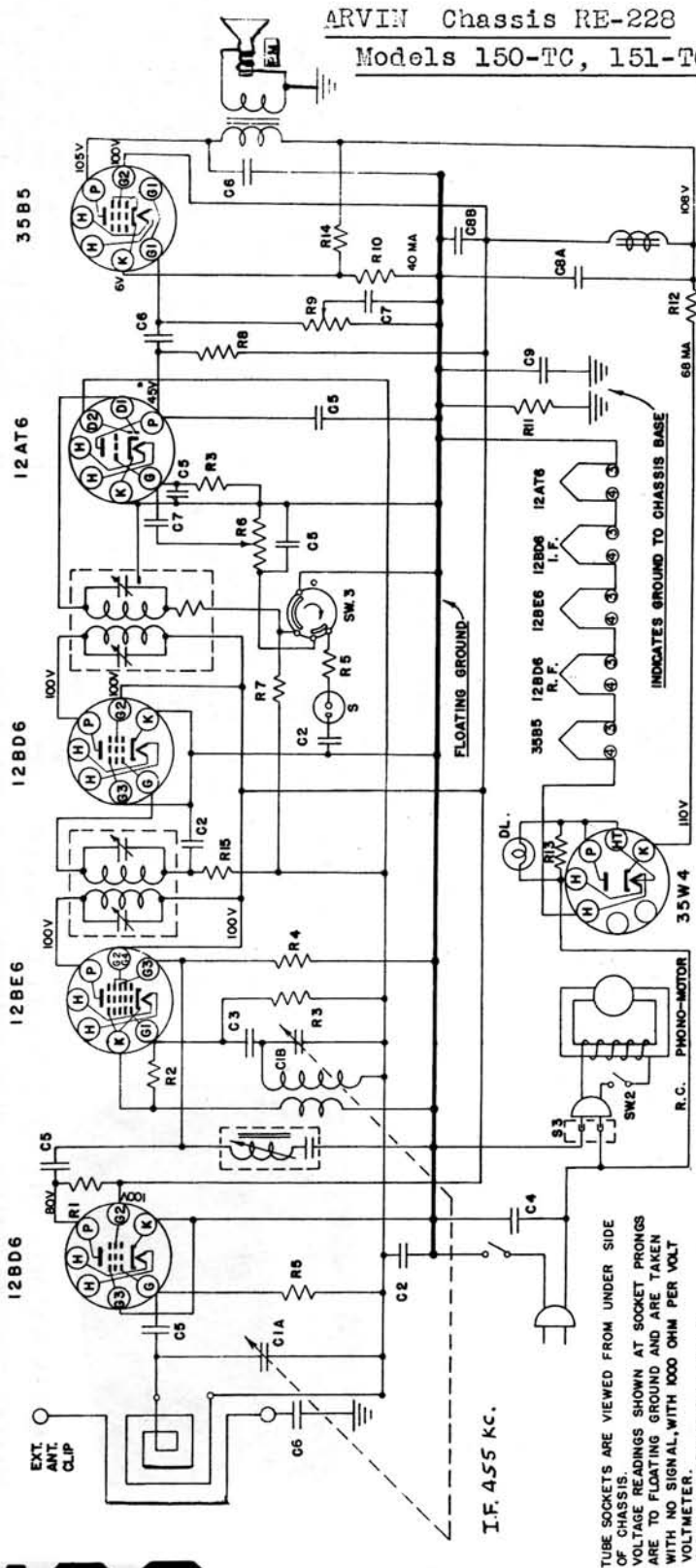

TUBE SOCKETS ARE VIEWED FROM UNDER SIDE OF CHASSIS.
VOLTAGE READINGS SHOWN AT SOCKET PRONGS ARE TO FLOATING GROUND AND ARE TAKEN WITH NO SIGNAL, WITH 1000 OHM PER VOLT VOLTMETER.
A.C. LINE VOLTAGE AT 117 VOLTS.
* MEASURED WITH VACUUM TUBE VOLTMETER.

SOCKET VOLTAGE AND RESISTANCE MEASUREMENTS

REP. NO.	PART NO.	DESCRIPTION	RESISTANCE																				
			1	2	3	4	5	6	7	8	9	10	11	12	13	14	15	16	17	18	19	20	
R1	C20060-222	Resistor, 2200 ohm 1/4 W																					
R2	C20060-223	Resistor, 22,000 ohm 1/4 W																					
R3	C20060-106	Resistor, 10 megohm 1/4 W																					
R4	C20060-224	Resistor, .22 megohm 1/4 W																					
R5	C20060-105	Resistor, 1 megohm 1/4 W																					
R6	C19927	Volume Control, 1 megohm																					
R7	C20060-225	Resistor, 2.2 megohm 1/4 W																					
R8	C20060-474	Resistor, .47 megohm 1/4 W																					
R9	C19928	Tone Control & Switch, .5 megohm																					
R10	C20060-151	Resistor, 150 ohm 1/4 W																					
R11	C20060-334	Resistor, .33 megohm 1/4 W																					
R12	C20060-220	Resistor, 22 ohm 1/4 W																					
R13	C20060-331	Resistor, 330 ohm 1/4 W																					
R14	C20070-123	Resistor, 12,000 ohm 1/4 W																					
R15	C20060-104	Resistor, .1 megohm 1/4 W																					
C1A-C1B	AD2111-1	Variable Condenser & Pulley Assy.																					
C2	C20067-503	Condenser, .05 uf 200 V, Paper																					
C3	C20065-500	Condenser, .00005 uf 500 V, Mica																					
C4	C20065-503	Condenser, .05 uf 400 V, Paper																					
C5	C20065-231	Condenser, .00025 uf 500 V, Mica																					
C6	C20068-103	Condenser, .01 uf 400 V, Paper																					
C7	C20068-502	Condenser, .005 uf 400 V, Paper																					
C8A-C8B	A21349	Electrolytic Condenser, 50-30 uf., 15V																					
C9	C20068-104	Condenser, .1 uf 400 V, Paper																					

All readings are taken from the socket terminal indicated to floating ground, with AC line voltage at 117V.
Voltage measurements made with 1000 ohm per volt voltmeter except where indicated otherwise.
* Measured with a vacuum tube voltmeter.
** Average measured with a vacuum tube voltmeter, $\pm 7.7V$ with variable condenser closed, $-9.8V$ with variable condenser open.
One meg. lower resistance with Phono-Radio Sw in Phono Position.

RESISTANCE OF COILS
Oscillator Cathode winding, .75 ohms
Grid winding, 6. ohms
Electrolytic Condenser, 50-30 uf., 15V
Condenser, .1 uf 400 V, Paper

First IF Transformer Primary winding 14 ohms
Secondary winding 14 ohms
B Choke 26 ohms

Second IF Transformer Primary winding 13 ohms
Secondary winding 13 ohms
47K Resistor in Series Inside Can

Output Transformer Primary 110 ohms
Secondary .3 ohms

MANUAL OF 1948 MOST-OFTEN-NEEDED RADIO DIAGRAMS

Packard-Bell

SERVICE DATA . . . MODEL 5DA

All D.C. voltages measured with a vacuum tube voltmeter from socket contacts to ground buss.—A.C. voltages measured with a 1000 ohms per volt A.C. meter from socket contacts to ground buss.*—Volume Control maximum.—No signal.—117 volts A.C. line voltage.—All voltages shown are positive D.C. unless otherwise noted.
*NOTE: Filament voltages should be measured across the filament of the tube.

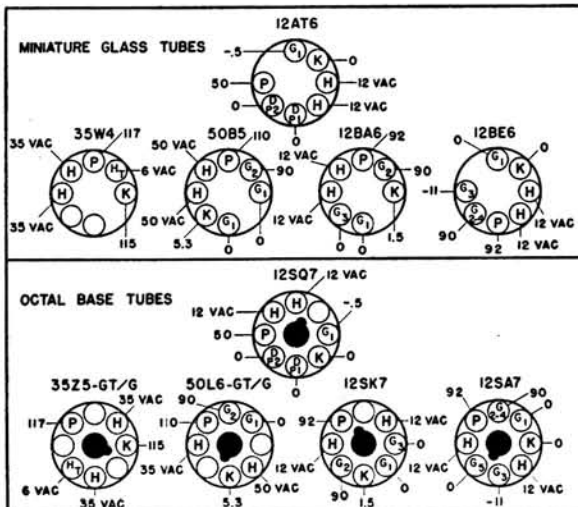

*R1-1, 220,000 ohm resistor, is used only in sets utilizing metal, octal base tubes.

ALIGNMENT PROCEDURE

Alignment Procedure consists of the four steps outlined in the Alignment Procedure Chart.

For Step No. 1, I.F. Alignment, connect the leads of a test oscillator to the mixer grid and the ground buss through an .01 Mfd. capacitor (dummy load). Upon completion of this step "Rock" the variable condenser to assure that the I.F.s have been aligned to the correct frequency. Output should remain constant at any setting of the variable condenser.

ALIGNMENT CHART

STEP	CONNECT TEST OSC. TO	TEST OSC. SETTING	ADJUST POINTER FOR MAX. SETTING	ADJUST FOR MAX. OUTPUT
1	Mixer Grid & Grd. .01 Mfd. Cap.	455 KC	540 KC	Trimms A, B, C, & D
2	Standard* Test Loop	1740 KC	1740 KC	Trimmer E to 1740 KC
3	Standard* Test Loop	1500 KC	1500 KC	Trimmer F
4	Standard* Test Loop	600 KC	600 KC	Loop

*NOTE: Hazeltine Standard Test Loop No. 1150 or a reasonable substitute.

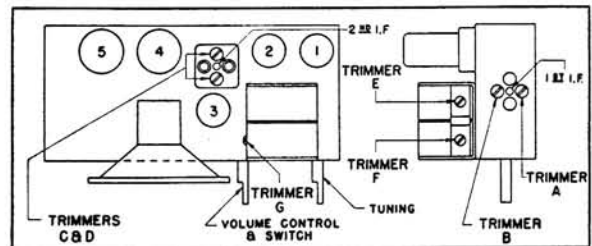

*180 ohm 1/2 watt resistor used for sets employing miniature glass tubes.

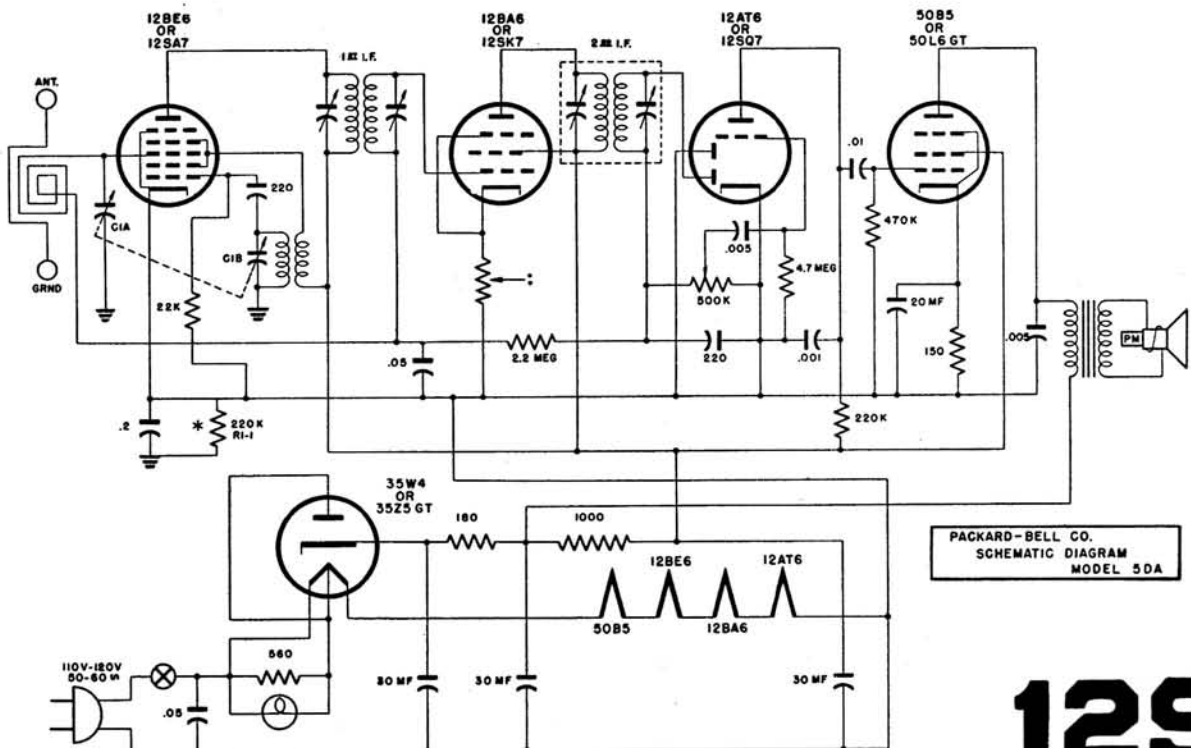

MANUAL OF 1948 MOST-OFTEN-NEEDED RADIO DIAGRAMS

Packard-Bell

SERVICE BULLETIN — MODEL 471
PORTABLE RECEIVER

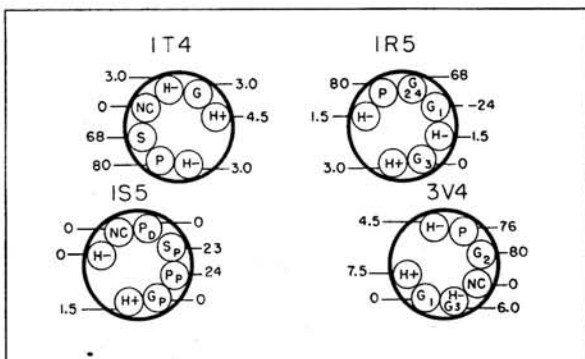

TUBE VOLTAGE CHART

NOTE: VOLTAGES TAKEN FROM B- WITH V.T.V.M.—NO SIGNAL

STAGE GAIN MEASUREMENTS

- Standard Output . . . 50 mw
- Dummy Antenna01 mfd.
- Volume Control . . . Maximum
- Converter grid to 1st I.F. grid . . . 51 X at 1000 KC
- Converter grid to 1st I.F. grid . . . 65 X at 455 KC
- 1st I.F. grid to 2nd detector . . . 55 X at 455 KC
- Overall audio gain014V at 1S5 grid — 100 mw output 400 cycles

D.C. Resistance Measurements

- 1st I.F. Coil
 - Primary 20 ohms
 - Secondary 20 ohms
- 2nd I.F. Coil
 - Primary 15 ohms
 - Secondary 15 ohms
- Oscillator Coil
 - Primary 3 ohms
 - Secondary 7 ohms

ALIGNMENT CHART

STEP	CONNECT TEST OSC. TO	TEST OSC. SETTING	POINTER SETTING	ADJUST FOR MAX. OUTPUT
1	Conv. Grid .01 Mfd. Dum. Ant.	455 KC	1620 KC	I.F. Trimmers A, B, C, D
2	Conv. Grid .01 Mfd. Dum. Ant.	1620 KC	1620 KC	Oscillator Trimmer E
3	*Standard Test Loop	1500 KC	1500 KC	Ant. Trimmer F
4	*Standard Test Loop	600 KC	600 KC	Loop
5	Repeat Step No. 3			

NOTE: Hazeltine Test Loop No. 1150 or equivalent.

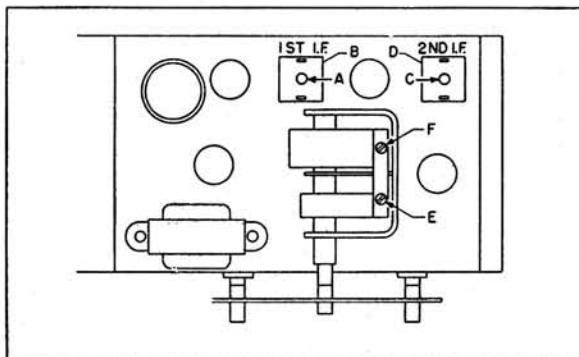

TRIMMER LOCATIONS

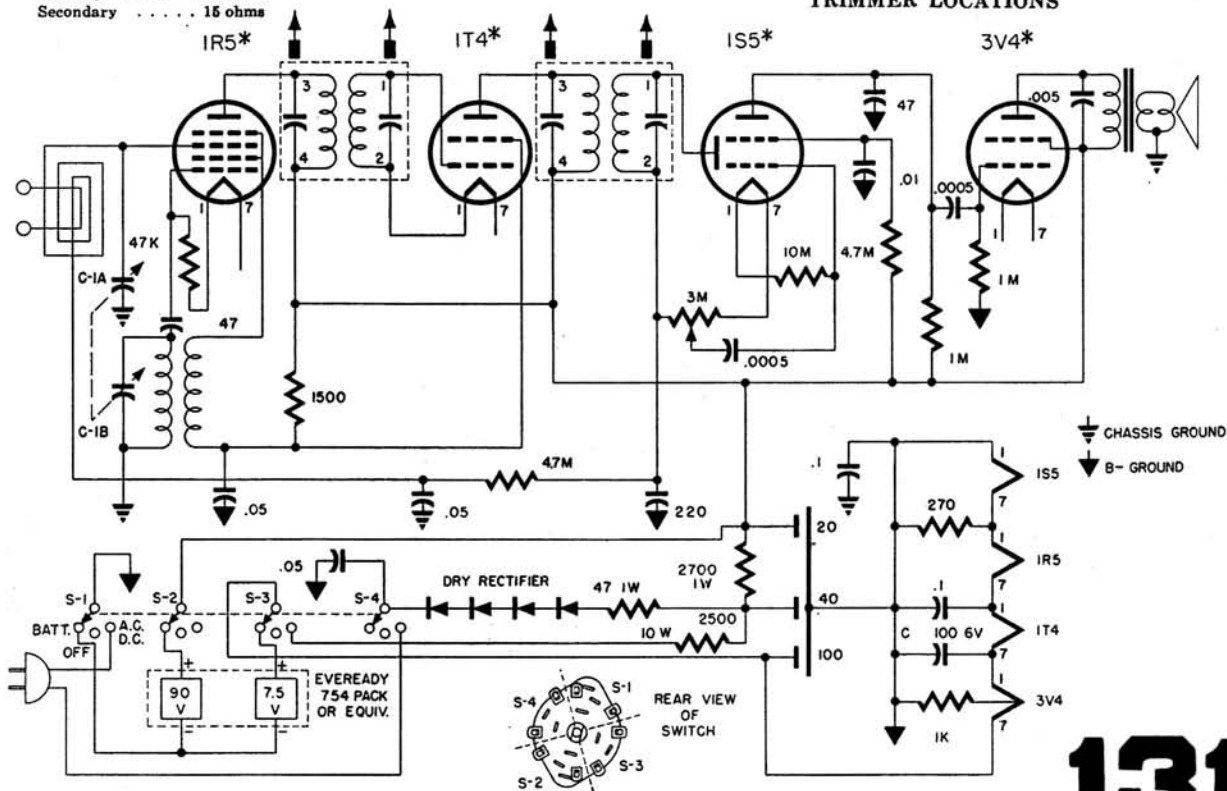

* SUPPRESSOR GRIDS TIED INTERNALLY AND NOT SHOWN IN SCHEMATIC

MANUAL OF 1948 MOST-OFTEN-NEEDED RADIO DIAGRAMS

132

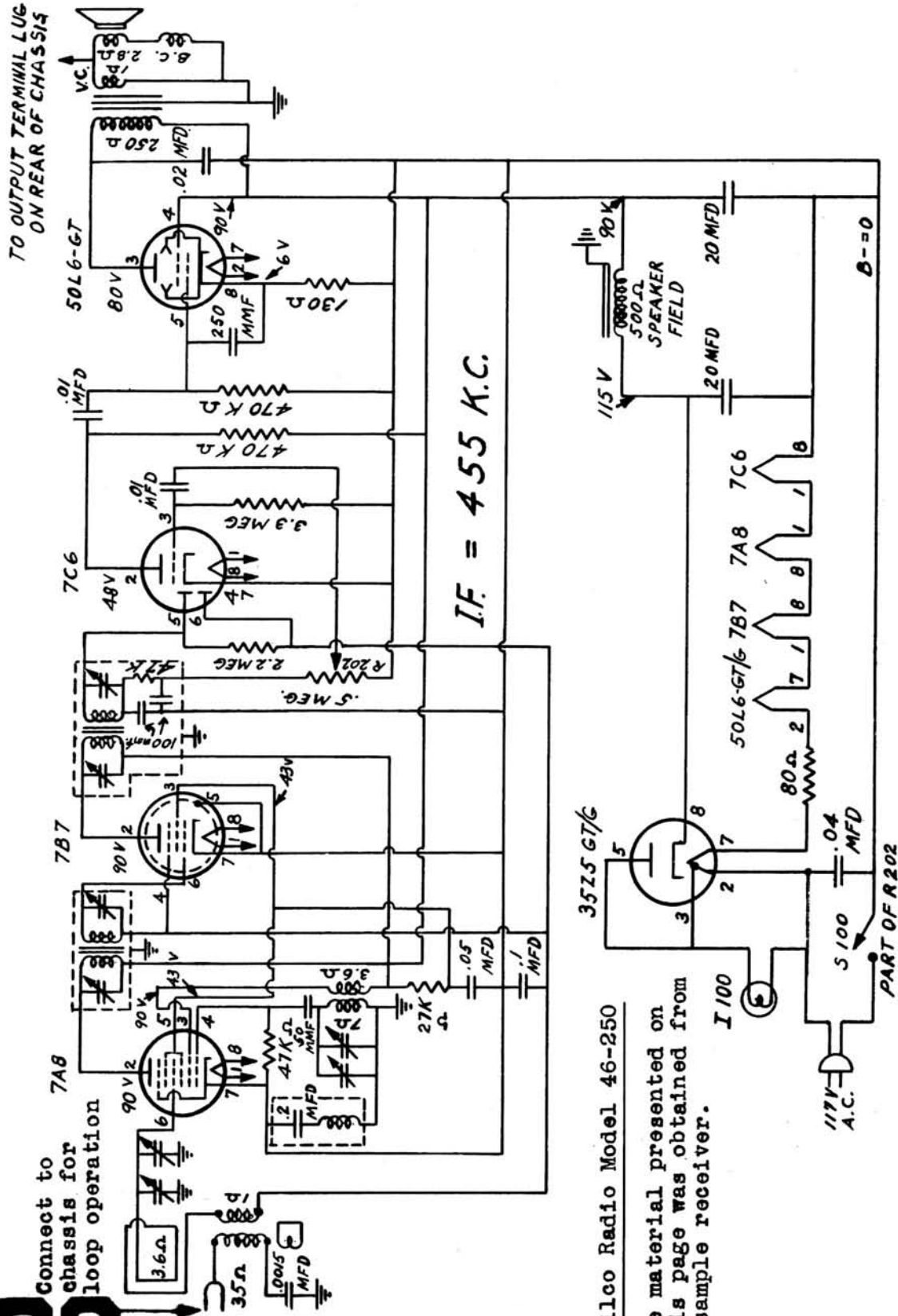

Philco Radio Model 46-250

The material presented on this page was obtained from a sample receiver.

Voltage measurements made with a 20,000 ohms/volt meter.

MANUAL OF 1948 MOST-OFTEN-NEEDED RADIO DIAGRAMS

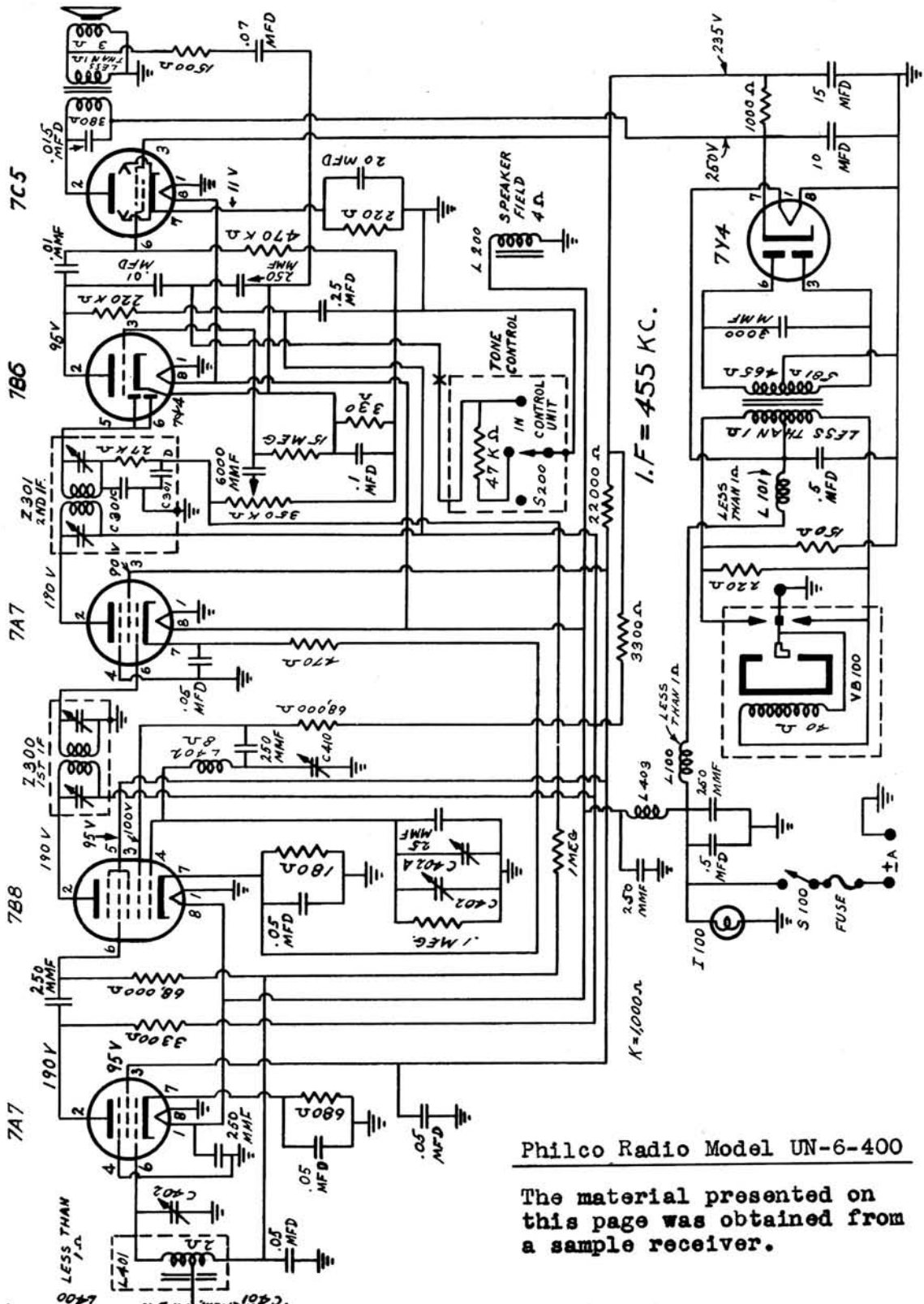

Philco Radio Model UN-6-400

The material presented on this page was obtained from a sample receiver.

Voltage measurements made with a 20,000 ohms/volt meter.

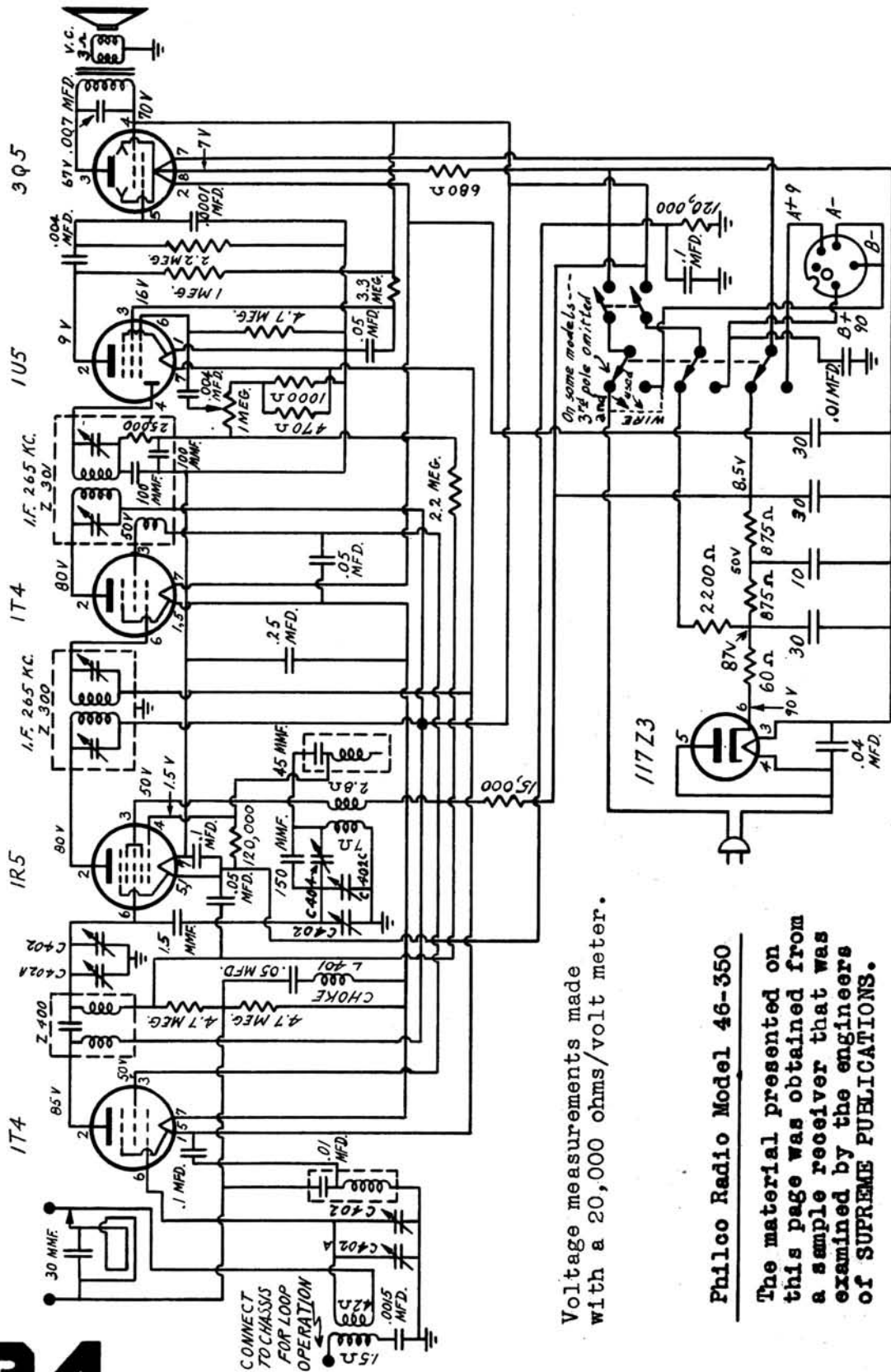

Voltage measurements made with a 20,000 ohms/volt meter.

Philco Radio Model 46-350

The material presented on this page was obtained from a sample receiver that was examined by the engineers of SUPREME PUBLICATIONS.

MANUAL OF 1948 MOST-OFTEN-NEEDED RADIO DIAGRAMS

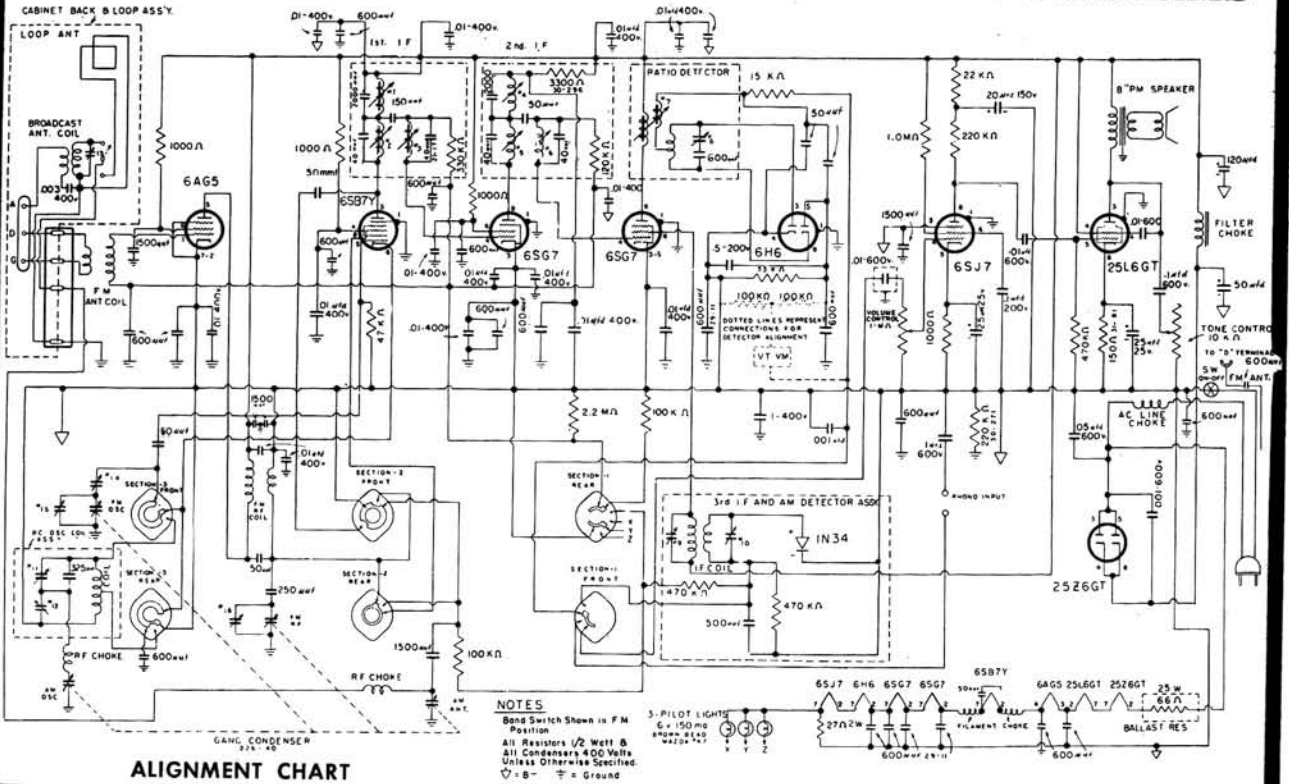

ALIGNMENT CHART

CIRCUIT ALIGNED	RECEIVER		SIGNAL GENERATOR		METER CONNECTIONS		TRIMMER OR SLUG ADJUST	PROCEDURE	
	STEP	BAND SWITCH	DIAL POINTER	FREQ.	CONNECTIONS	TYPE See List			
AM I.F.	1	BC	55	455 KC	Through .1 MFD cap. to Grid of 6SB7Y	A	Across Voice-Coil of Speaker	1, 4, 9, 10	Adjust for Maximum Output
FM I.F.	2	FM	88	10.7 MC	Through .1 MFD cap. to Grid of 6SB7Y	A	Across Voice-Coil of Speaker	2, 3, 5, 6, 7, 8	Adjust for Maximum Output
Ratio-detector	3	FM	88	10.7 MC	Through .1 MFD cap. to Grid of 6SB7Y	B	From: Junction of two 100K resistors connected across 47K load resistor of the ratio detector. To: Audio output of ratio detector. (See Circuit Diagram)	8	Adjust meter to zero. (Check proper zero set. Meters should register reverse polarity when trimmer is turned slightly to the right, and then to the left of zero output)
Broadcast R.F.	4	BC	150	1500 KC	Through 200 mmf. cap. to Antenna "A" Post on back.	A	Across Voice-Coil of Speaker	12, 13	Adjust for maximum output
	5	BC	60	600 KC	Through 200 mmf. cap. to Antenna "A" Post on back.	A	Across Voice-Coil of Speaker	11	Adjust for maximum output while rocking variable condenser
6 REPEAT STEPS 4 5 AND REPLACE BOTTOM COVER OF CHASSIS									
Frequency Modulation	7	FM	106	106 MC	To "D" and "G" Antenna Terminals	A	Across Voice-Coil of Speaker	15, 16	Adjust for maximum output
R.F.	8	FM	90	90 MC	To "D" and "G" Antenna Terminals	A	Across Voice-Coil of Speaker	14	Adjust for maximum output
9 REPEAT STEPS 7 AND 8									

PILOT RADIO
MODEL T-521

137

MANUAL OF 1948 MOST-OFTEN-NEEDED RADIO DIAGRAMS

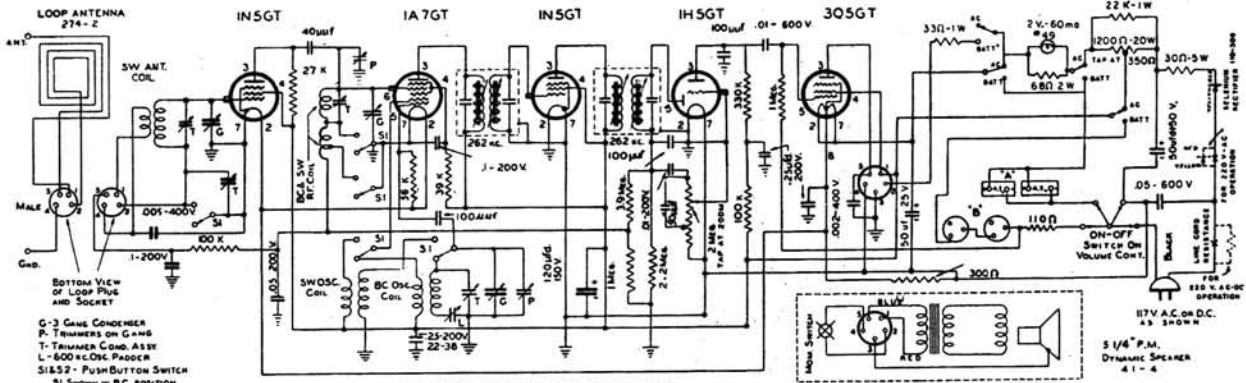

G-3 GAGE CONDENSER
 P- TRIMMERS ON G-ANG
 T- TRIMMER COND. A15V
 L- 600 KC OSC. PADDER
 S1 S2 - PUSH BUTTON SWITCH
 S1 SHOWN IN BC POSITION
 S2 SHOWN IN AC-DC POSITION

ALL RESISTORS ARE 1/2 WATT UNLESS OTHERWISE SPECIFIED

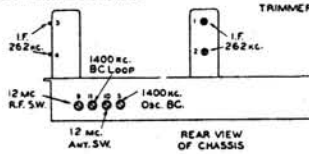

TRIMMER LAYOUT

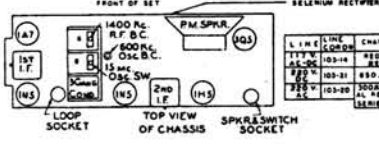

FRONT OF SET

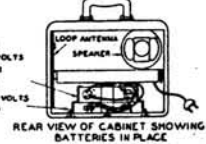

REAR VIEW OF CABINET SHOWING BATTERIES IN PLACE

SERVICE NOTES

The location and sequence of the screws for adjusting the ANT., R.F., and I.F. circuits, are illustrated on the diagram. The I.F. amplifier may be aligned with the chassis out of the cabinet but with the loop antenna plugged in. For the I.F. alignment the signal generator must be connected to the grid of the 1A7GT tube through a .1 mfd. condenser. The R.F. trimmers should also be peaked for maximum with the chassis out of the cabinet. When aligning the ANT. trimmers, the "A" and "B" batteries must be in place, the loop antenna and receiver correctly mounted in the cabinet. The receiver may be aligned on either batteries or house current. When the receiver is aligned on the broadcast band, connect the signal generator to the ANT. post at the back through a .0002 mfd. condenser, and on the shortwave band use a 400 ohm carbon resistor.

When removing the batteries, first unscrew clamps, and then remove battery plugs. Be sure not to pull on the cables, but on the plugs themselves.

Place the new "A" and "B" batteries in position shown on diagram and replace clamps in position.

The blue and white cable, coming from the chassis, has two 2-prong plugs which are then plugged into the "A" batteries. The red and black cable has two 3-prong plugs, both of which are plugged into the "B" batteries.

Pilot



Model T-570

RADIO CORPORATION

ALIGNMENT NOTES

See Alignment chart on next page.

The following notes are intended for the use of an expert radio technician:

Alignment should be attempted only if the proper meter and signal generator are at your disposal. Insulated alignment tools are necessary. Output meters should include A) a low range AC meter, B) a 0-20 volt DC vacuum tube voltmeter.

The signal generator must cover the frequencies of 455 kc, 600 kc, 1500 kc, 10.7 mc, 90 mc and 106 mc.

During alignment the line voltage feeding the receiver power-supply should be kept at approximately 117 volts.

The receiver should be allowed to warm up for at least 30 minutes before making any adjustments.

The locations of adjustment screws are indicated clearly on the schematic diagram. Alignment adjustments should be made only in the sequence given in the chart.

- | | |
|-------------------------------------|-------------------------------------|
| 1-1st I.F. 455 Kc | 9- AM 3rd I.F. 455 Kc, Primary |
| 2-1st I.F. 10.7mc, Primary | 10- AM 3rd I.F. 455 Kc, Secondary |
| 3-1st I.F. 10.7mc, Secondary | 11- BC Osc. Padder |
| 4-2nd I.F. 455 Kc | 12- BC Osc. Trimmer |
| 5-2nd I.F. 10.7mc, Primary | 13- Ant. BC Trimmer (on rear cover) |
| 6-2nd I.F. 10.7mc, Secondary | 14- FM Osc. Padder |
| 7- Ratio Detector 10.7mc, Primary | 15- FM Osc. Trimmer |
| 8- Ratio Detector 10.7mc, Secondary | 16- FM R.F. Trimmer |

ALIGNMENT ADJUSTMENTS

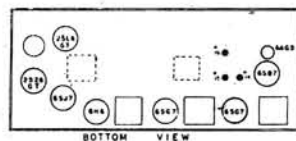

BOTTOM VIEW

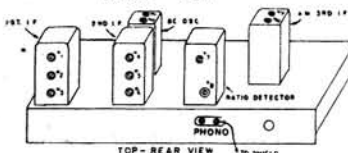

TOP-REAR VIEW

FRONT SECTION

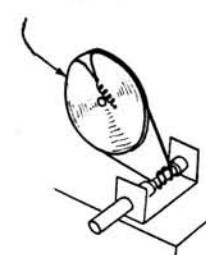

Pilot

RADIO CORPORATION

MODEL T-521

A.C.-D.C. Receiver

REAR SECTION OF PULLEY

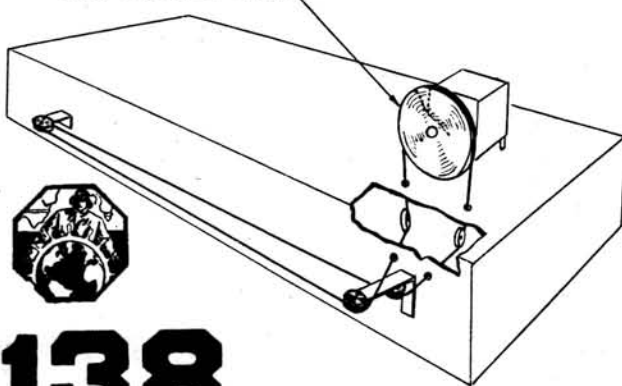

138

MANUAL OF 1948 MOST-OFTEN-NEEDED RADIO DIAGRAMS

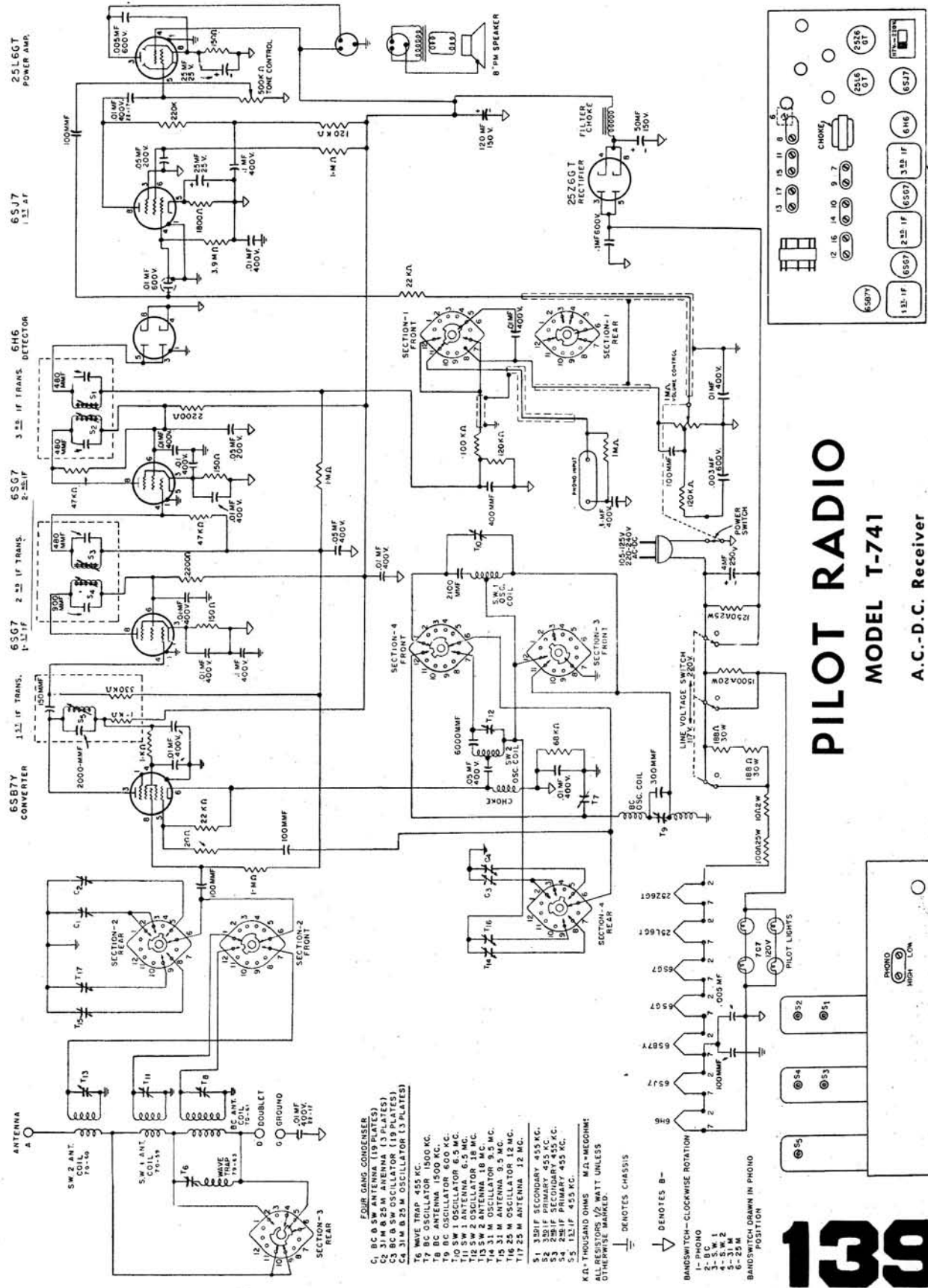

- FOUR GANG CONDENSER**
 C1, BC 9 SW ANTENNA (19 PLATES)
 C2, 31 M 25 M ANTENNA (13 PLATES)
 C3, 31 M 25 M ANTENNA (13 PLATES)
 C4, 31 M 25 M OSCILLATOR (13 PLATES)
- WAVE TRAP** 455 KC.
 T7, BC OSCILLATOR 1500 KC.
 T8, BC ANTENNA 1500 KC.
 T9, BC OSCILLATOR 600 KC.
 T10, SW 1 OSCILLATOR 65 MC.
 T11, SW 2 OSCILLATOR 18 MC.
 T12, SW 2 ANTENNA 18 MC.
 T13, SW 1 ANTENNA 18 MC.
 T14, SW 1 ANTENNA 5 MC.
 T15, 25 M OSCILLATOR 12 MC.
 T16, 25 M ANTENNA 12 MC.
- 5Y1 350F SECONDARY 455 KC.**
 5Y2 350F PRIMARY 455 KC.
 5Y3 250F SECONDARY 455 KC.
 5Y4 250F PRIMARY 455 KC.
 5Y5 131F 455 KC.
- K.O. THOUSAND OHMS M.I. MEGOHMS:**
 ALL RESISTORS 1/2 WATT UNLESS OTHERWISE MARKED
- ⊖ DENOTES CHASSIS**

▷ DENOTES B-
BANDSWITCH—CLOCKWISE ROTATION
 1—PHONO
 2—S.W. 1
 3—S.W. 2
 4—S.W. 2
 6—25 M
BANDSWITCH DRAWN IN PHONO POSITION

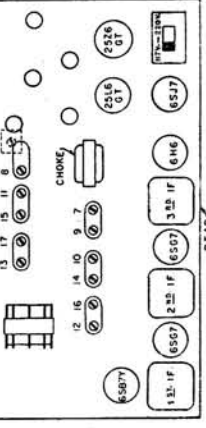

PILOT RADIO MODEL T-741 A.C.-D.C. Receiver

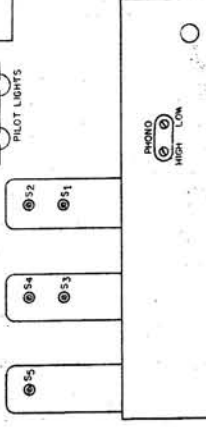

MANUAL OF 1948 MOST-OFTEN-NEEDED RADIO DIAGRAMS

PILOT RADIO - MODEL T-601

ALIGNMENT CHART

Tuning Range 88-108 Mc.

Insulated alignment tools are necessary. The output meter should be a D.C. vacuum tube voltmeter with a range of at least 20 volts. The signal generator should cover the frequencies of 10.7, 90 and 106 mc. Allow the PILOTUNER to warm up for at least 30 minutes before making any adjustments. The location of the adjustment screws is indicated clearly on the schematic diagram. Follow the sequence in the alignment chart.

CIRCUIT ALIGNED	STEP	RCVR. DIAL POINTER	SIGNAL GEN.		METER CONNECTIONS	TRIMMER OR SLUG ADJUSTMENT	PROCEDURE
			FREQ.	CONNECTIONS			
IF	1	88 mc	10.7 mc	Through .01 mfd. cap. to grid of 6BE6	Across two 100K resistors —indicated by dotted lines in schematic	S2, S1, S4, S3, S6, S5	Adjust for maximum output
	2		Repeat Step No. 1				
Ratio Detector	3	88 mc	10.7 mc	Same as No. 1	From: Junction of two 100K resistors TO: Audio output of ratio detector. Connections indicated by dotted lines in schematic	S1	Adjust meter to zero (Check proper zero set) Meter should register reverse polarity when slug is rotated through zero output.
Oscillator	4	90 mc	90 mc	Through carbon 300 ohm resistor to Ant. Terminal	Same as Step No. 1	P8	Same as Step No. 1
	5	106 mc	106 mc	Same as No. 4	Same as No. 1	T7	Same as No. 1
	6		Repeat Steps No. 4 & 5				
	7	90 mc	90 mc	Same as No. 4	Same as No. 1	P10	Same as No. 1
RF	8	106 mc	106 mc	Same as No. 4	Same as No. 1	T9	Same as No. 1

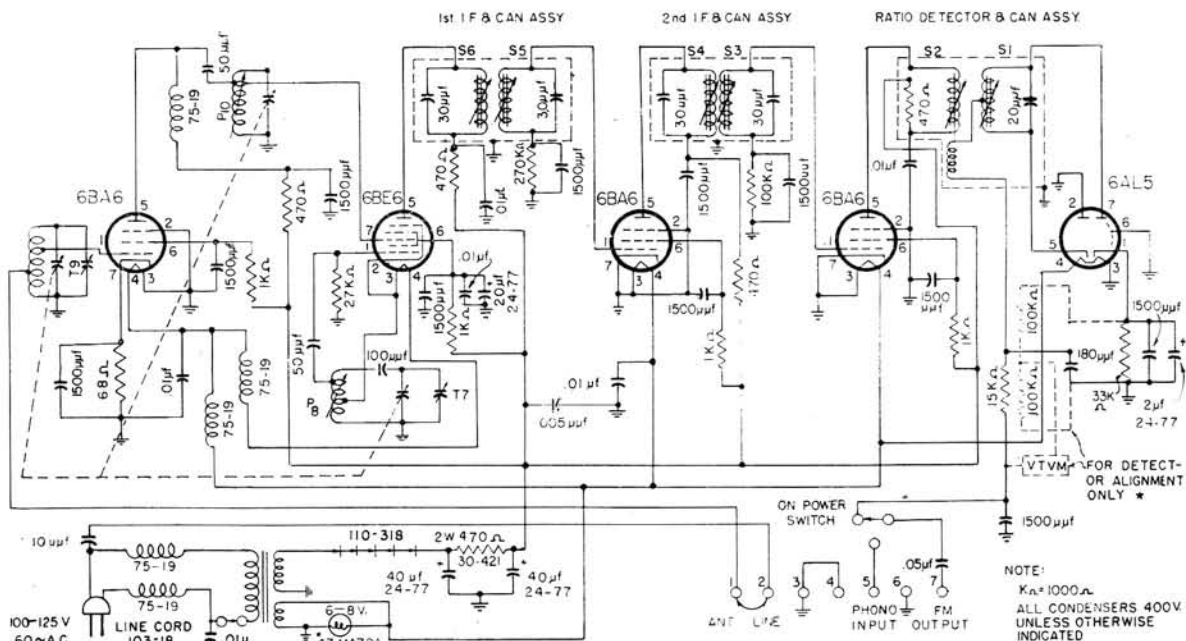

NOTE:
K_Ω = 1000 Ω
ALL CONDENSERS 400V UNLESS OTHERWISE INDICATED

- S1 RATIO DETECTOR SEC.
- S2 RATIO DETECTOR PRI.
- S3 2ND IF SEC.
- S4 2ND IF PRI.
- S5 1ST IF SEC.
- S6 1ST IF PRI.
- T7 OSC. TRIMMER
- P8 OSC. PADDER
- T9 ANT. TRIMMER
- P10 R.F. PADDER

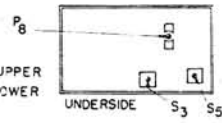
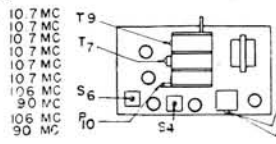

TO ALIGN RECEIVER USE FREQUENCIES AS INDICATED ON LEFT. ADJUST ALL TRIMMERS FOR MAX. D.C. OUTPUT ACROSS 33K Ω RESISTOR IN 6AL5 CIRCUIT.
* TO ALIGN SECONDARY OF RATIO DETECTOR CONNECT METER AS INDICATED IN SCHEMATIC AND ADJUST S₁ FOR ZERO OUTPUT.

MANUAL OF 1948 MOST-OFTEN-NEEDED RADIO DIAGRAMS

RCA VICTOR VICTROLA Model 63E, 63EM Chassis No. RS-127 Mfr. No. 274

Irregular Turntable Speed:

- (1) Oil or grease on rubber tire of turntable drive wheel. Remove turntable and clean drive wheel tire, and inside edge of turntable with naphtha or carbon-tetrachloride.
- (2) Insufficient tension in drive wheel tension spring.
- (3) Lack of lubrication.

Replacement of Sapphire

CAUTION: Never bend the sapphire support wire.

The nut on the sapphire holder assembly may be locked by a light cement. Extreme care should be used when loosening the nut so that the twisting motion does not break the crystal.

Remove the two screws holding the sapphire guard in place and remove guard. Remove the small nut and washer on the threaded shaft of the sapphire holder and gently push the shaft through the hole in the armature shaft until the sapphire holder assembly comes free.

Use of a drop or two of acetone will facilitate the removal of the nut and shaft if cement has been used. Do not use force as the crystal may be broken.

Insert threaded shaft of replacement sapphire holder through armature shaft and replace the washer and nut. Make sure that the sapphire is in the correct position. Take hold at the lower end of the shaft with a pair of pliers while tightening the nut, being very careful so as not to strip the threads or break the crystal. Replace the sapphire guard, positioning it by means of the oversize screw slots. Make certain that the sapphire and its supporting wire are centered in the guard. Tighten the guard screws. Before using, check to see that the sapphire projects far enough (approx. .020") beyond the guard so that the guard will not strike the record. If necessary, bend the guard a little.

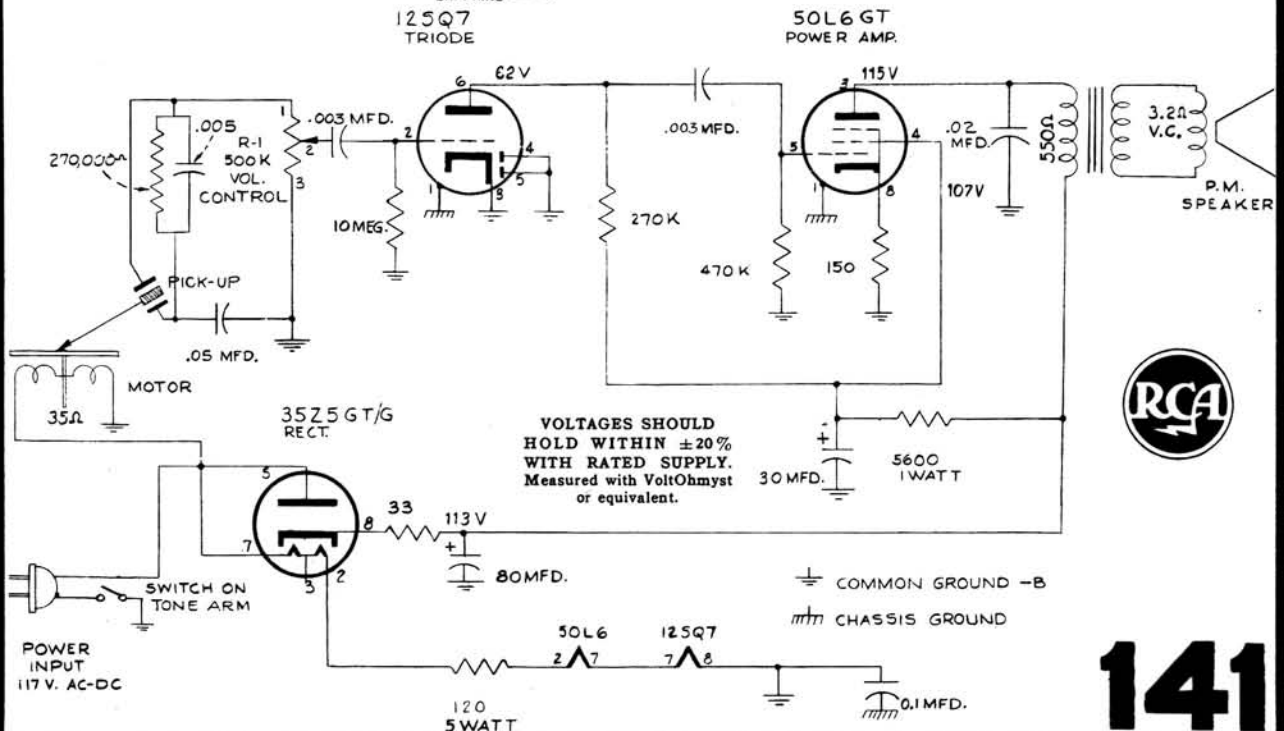
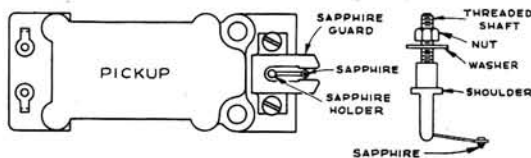

Lubrication

Motor

The bearings of the motors furnished in these instruments are lubricated at the factory and should require no further lubrication for a period of at least one year. When lubrication is required, apply a few drops of any good grade of S.A.E. #10 oil to the bearing felts.

Turntable Spindle

When lubrication is required, apply one or two drops of Gargoyle 600W to the bearing.

Drive Wheel

Apply one or two drops of any good grade of S.A.E. #10 oil to the bearing felt.

CAUTION: Exercise extreme care to prevent getting any oil on the rubber tire or on the motor shaft. Oil on these parts will cause slippage with resultant irregular turntable speed.

Service Hints

To Remove Turntable:

Remove "C" washer from turntable spindle and lift turntable straight up.

Motor Board Disassembly

- Remove the "C" washer on turntable spindle.
- Lift turntable straight up.
- Disconnect motor plug from power plug.
- Remove two screws exposed on top of cabinet.

To replace Drive Idler

- Remove "C" washer at bottom of drive idler wheel shaft.
- Lift idler drive wheel up from motor mounting board.

To remove turntable spindle disengage the spring clip from the bottom of the turntable spindle and lift up on the spindle.

To remove the motor from the motor mounting board, remove the three nuts from the top of the motor mounting board.

To remove the switch, unscrew the two screws holding the switch assembly to the pickup assembly.

Service Hints

- Failure to start when pickup is lifted.
 - Dirty switch contacts.
 - Weak or broken spring on pickup support arm.
 - Motor connector plug broken or dirty.

To Remove Pick-up Arm

- Remove the switch.
- Remove the spring clips from the rear pivot of the support arm.
- Disengage the tone arm lift spring from the support arm.
- Remove the spring clips from the front pivot of the support arm.
- Remove the "C" washer from the pick-up pivot arm.
- Pick-up is free to be removed when the two leads from the crystal are removed.



MANUAL OF 1948 MOST-OFTEN-NEEDED RADIO DIAGRAMS

RCA 54B5 Chassis No. RC1047

Alignment Procedure

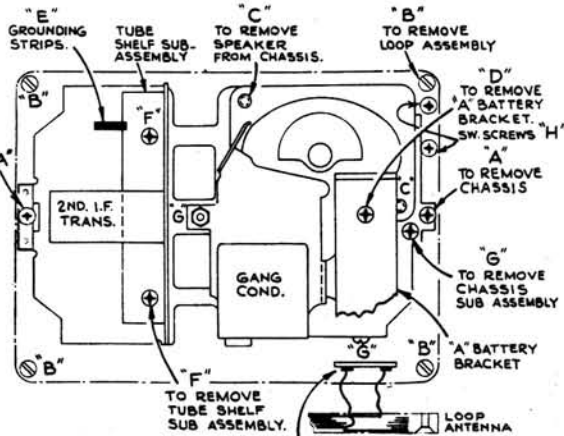

Test Oscillator.—Connect test oscillator as indicated in chart keeping the output as low as possible to avoid A V C action.

Output Meter.—Connect a high resistance AC voltmeter in series with a .1 mfd capacitor from top lug of TB1 (plate of 354) to ground. Turn volume control to maximum position.

When using the dummy case for the osc. alignment, the loop assembly must be raised slightly so that osc. trimmer becomes accessible.

Steps	Connect the high side of test osc. to—	Tune test-osc. to—	Turn radio dial to—	Adjust the following for max. peak output—
1	lug of C2, (located on rear of gang) through a .01 mfd. capacitor	455 kc	Quiet point near 1,600 kc	C11, C12 2nd I-F trans.
2		455 kc	Quiet point near 1,600 kc	C8, C9 1st I-F trans.
3		1,600 kc	1,600 kc	C5 (osc.)
4	**Antenna coupling loop thru 200 mmf. capacitor	1,500 kc	1,500 kc	C2 (ant.)
5		600 kc	600 kc	L2 (osc.) (Rock gang)
6	Repeat steps 4 and 5 for final adjustments.			

*The IF transformers can be aligned with chassis out of case.

**Steps 3, 4 and 5 require a coupling loop from the signal generator to feed a signal into the receiver loop located in the back. This loop should be approximately one turn of $6 \times 3\frac{1}{2}$ inches coupled to the signal generator through a 200 mmf. capacitor, and loosely coupled to the receiver loop antenna at about $1\frac{1}{4}$ inches distance, so as not to disturb the receiver loop inductance. Ground test oscillator through .1 mf. capacitor to receiver chassis.

CRITICAL LEAD DRESS

1. Dress blue, green and black leads of second IF transformer as direct as possible. If excess lead exists, dress down side of socket and flat against chassis to transformer opening.
2. Cross the green and the black leads inside the first IF transformer can, keeping the green lead to the outside. Load coil bracket is to separate the blue and the green leads.
3. Dress audio coupling capacitor C14 and the lead to the volume control up and underneath shelf supporting the output transformer.
4. Wire in the three capacitors pyramided behind the speaker with enough space behind the battery holder to allow holder to move when battery is replaced. Dress the ground leads of these capacitors to keep from shorting the off-on switch.
5. Observe the outside foil connections on all paper capacitors, also the polarity of the electrolytic capacitor C17.
6. Keep blue and red leads of output transformer above the mounting shelf.
7. Dress all leads as far as possible from loading coil.
8. Dress leads to gang as far as possible from all metal parts.
9. Dress loop leads to keep from interfering with battery replacement.

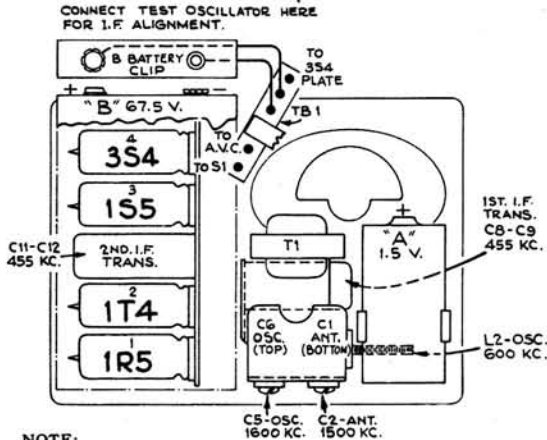

NOTE:
A rubber band should be placed around each tube for cushioning. Dirty tube contacts may be mistaken for a defective tube.

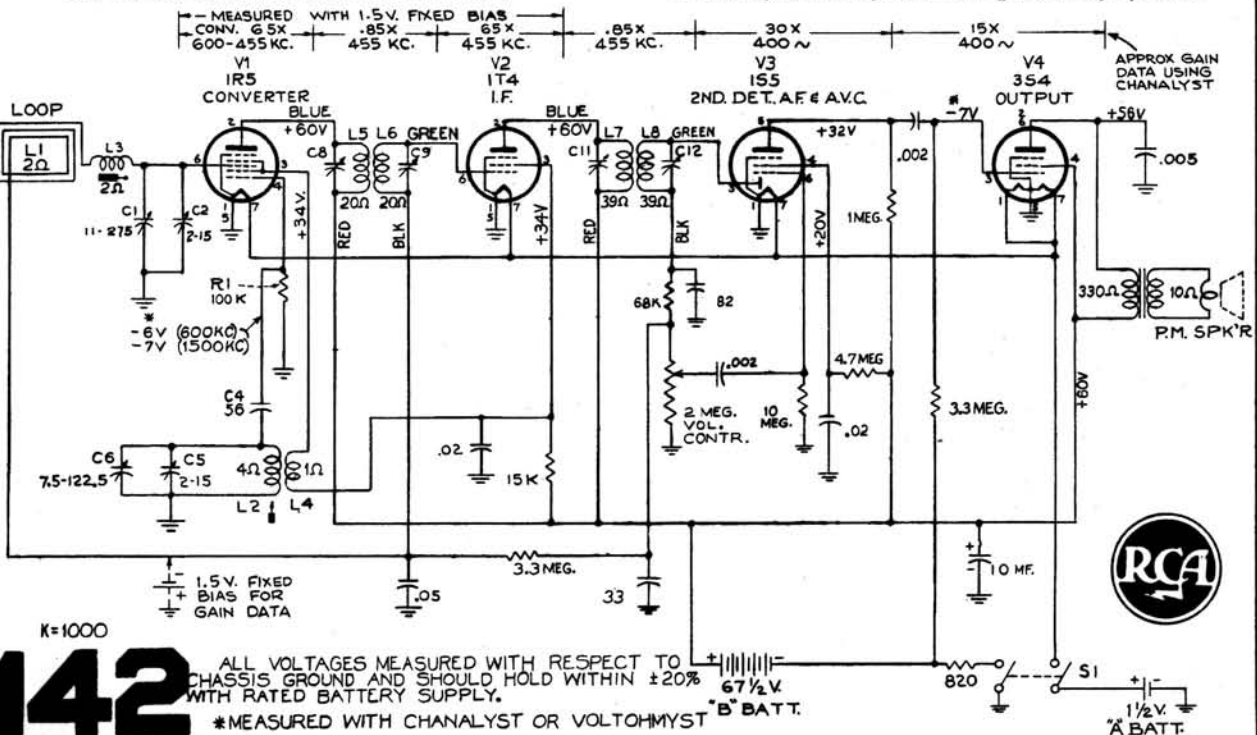

MANUAL OF 1948 MOST-OFTEN-NEEDED RADIO DIAGRAMS



RCA VICTOR

65F and CV-42 Electrifier

Chassis No. (RC-1004E) (RS-1000)

Cathode Ray Alignment is the preferable method. Connections for the oscillograph are shown in the diagram.

Output Meter Alignment.—If this method is used, connect the meter across the voice coil and turn the receiver volume control to maximum.

Test Oscillator.—For all alignment operations, connect the low side of the test oscillator to the receiver chassis, and keep the output as low as possible to avoid AVC action.

Pre-Setting Dial.—With gang condenser in full mesh, the pointer should be set at the left-hand end of calibration mark.

Step	Connect high side of the test oscillator to—	Tune test osc. to—	Turn radio dial to—	Adjust the following for maximum peak output
1	I-F grid in series with .01 mfd.	455 kc	Quiet point between 550 and 750 kc	C14, C15 (2nd I-F Trans.)
2	1A7GT grid in series with .01 mfd.			C12, C13 (1st I-F Trans.)
3	Antenna terminal in series with 200 mmfd.	1,720 kc	Tuning condenser rotor plates all out	C17 (osc.)
4		1,300 kc	1,300 kc signal	C9 (ant.)
5		455 kc	Quiet point between 550 and 750 kc	Adjust C22 for minimum output on strong 455 kc signal

Precautionary Lead Dress.—

1. The lead from the 3Q5 plate to output transformer should be dressed under clip, and away from audio input leads.
2. All filament wires should be dressed close to chassis.
3. Keep AVC lead connecting C1 (0.1 mfd. filter) to antenna coil away from the 1A7GT plate.
4. Keep blue plate leads coming from I.F. transformers short and close to chassis.
5. Keep yellow leads connected to oscillator coil away from trap coil.
6. Keep grid lead of 1N5GT RF tube away from 1A7GT grid.
7. Keep green lead from second I.F. transformer short and close to ground.

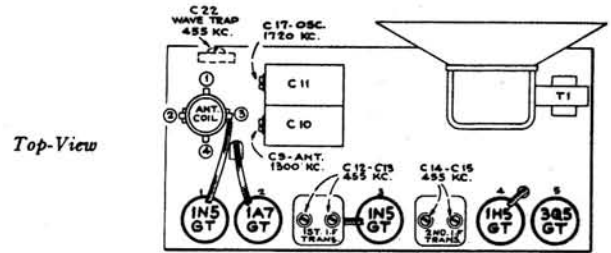

Top-View

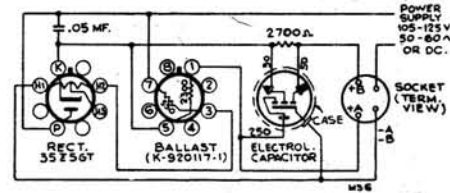
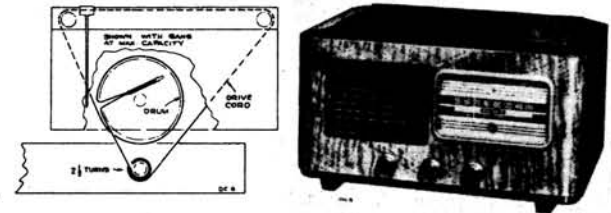

Electrifier Schematic

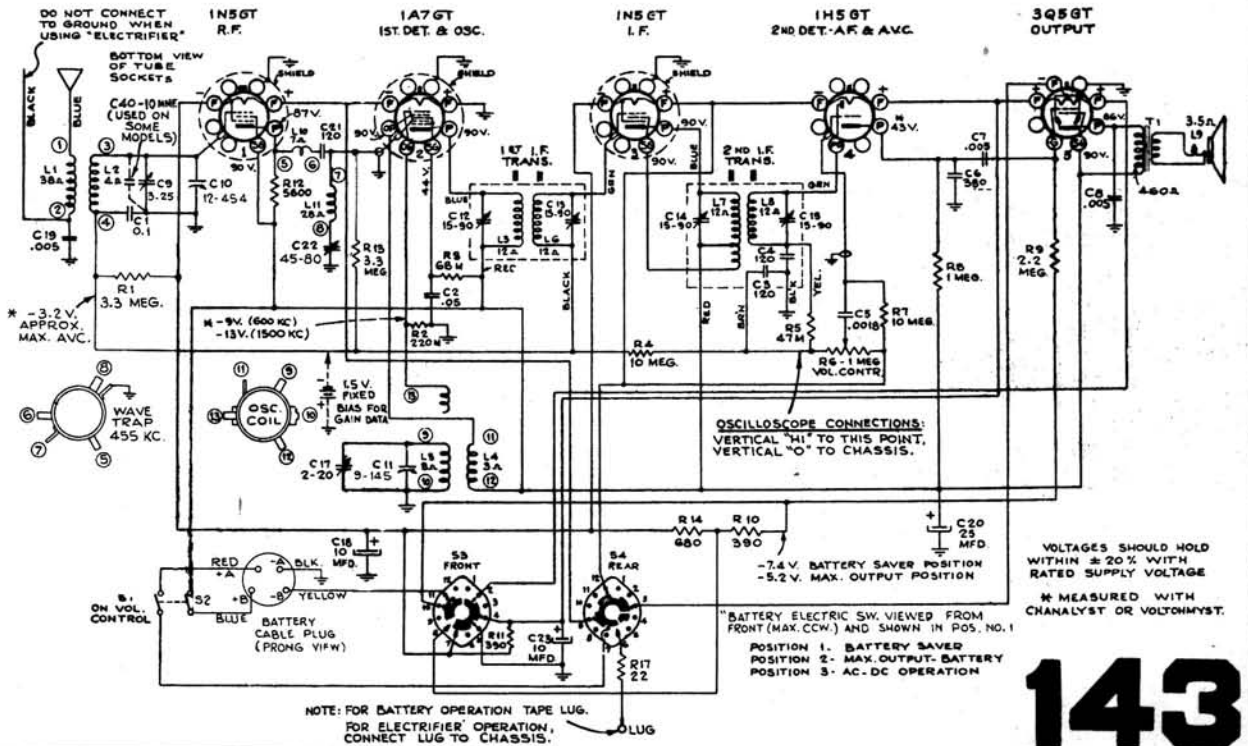
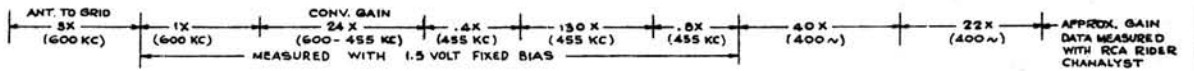

MANUAL OF 1948 MOST-OFTEN-NEEDED RADIO DIAGRAMS

RCA VICTOR

66X11, 66X12, 66X13

Chassis No. RC-1046A, RC-1046, RC-1046B

66X14, 66X15

RC-1046B

Alignment Procedure

Test Oscillator.—Connect high side of test oscillator as shown in chart. Connect low side through a .01 mf capacitor to common "—B." Keep the output signal as low as possible to avoid AVC action.

Output Meter.—Connect leads between speaker voice coil and chassis. Turn volume control to maximum clockwise, tone control to maximum highs (clockwise).

Dial Pointer Adjustment.—Rotate tuning condenser fully counterclockwise (plates closed). Adjust indicator pointer to $2\frac{1}{8}$ " from left hand edge of dial back plate.

Steps	Connect the high side of test-oscillator to—	Tune test-osc. to—	Turn radio dial to—	Adjust the following for max. peak output
1	Stator of C-12 in series with .01 mfd.	455 kc	Quiet-point 1,600 kc end of dial	Sec. and pri. 2nd I-F trans.
2				Sec. and pri. 1st I-F trans.
3	Ant. lead in series with 200 mmfd.	1,600 kc	1,600 kc	C14 (osc.)*
4		1,300 kc	1,300 kc	C13 ant.
5		600 kc	600 kc	L4 (osc.) Rock in
6	Repeat steps 3, 4 and 5.			

*Left hand osc. trimmer should be pre-set approx. $\frac{1}{4}$ turn from tight.

DISTANCES IN INCHES FROM LEFT HAND EDGE OF DIAL BACK PLATE

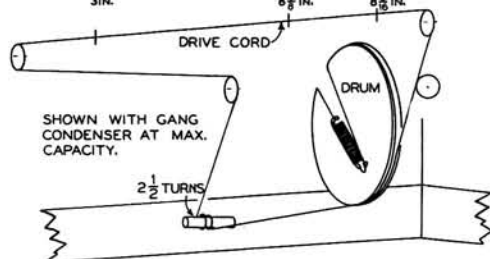

Dial-Indicator and Drive Mechanism

Critical Lead Dress

1. Dress output plate bypass capacitor (C-11 .02 mf) against chassis.
2. Dress 35L6GT plate lead (red) against chassis and away from volume control, leads and terminals.
3. Dress audio coupling capacitor (C-7 .02 mf) away from 35L6GT heater leads.
4. Dress tone control lead against front apron.
5. Dress 2nd i-f yellow and brown leads away from output plate bypass capacitor (C-11, .02 mf.) and away from all heater leads.
6. Dress lead to speaker voice coil away from tuning shaft "C" washer.
7. Dress tone control capacitor (C-10, .002 mf.) away from oscillator coil.
8. Dress all uninsulated leads away from each other and away from chassis to prevent short circuits.
9. Dress blue and green leads of both i-f transformers back in shields leaving exposed lengths as short as possible.

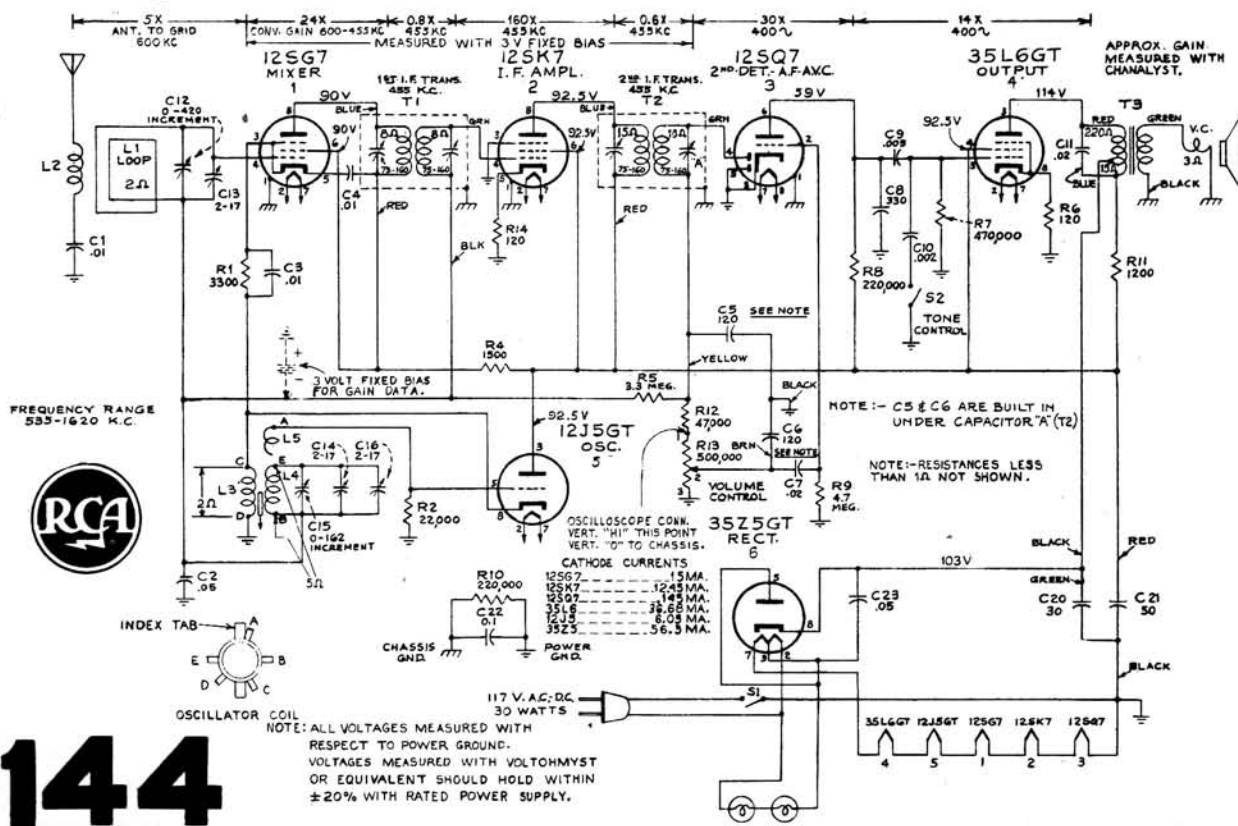
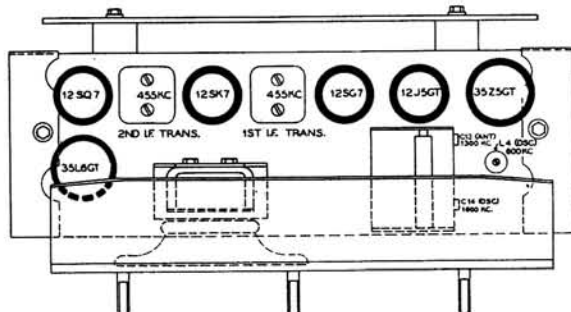

MANUAL OF 1948 MOST-OFTEN-NEEDED RADIO DIAGRAMS

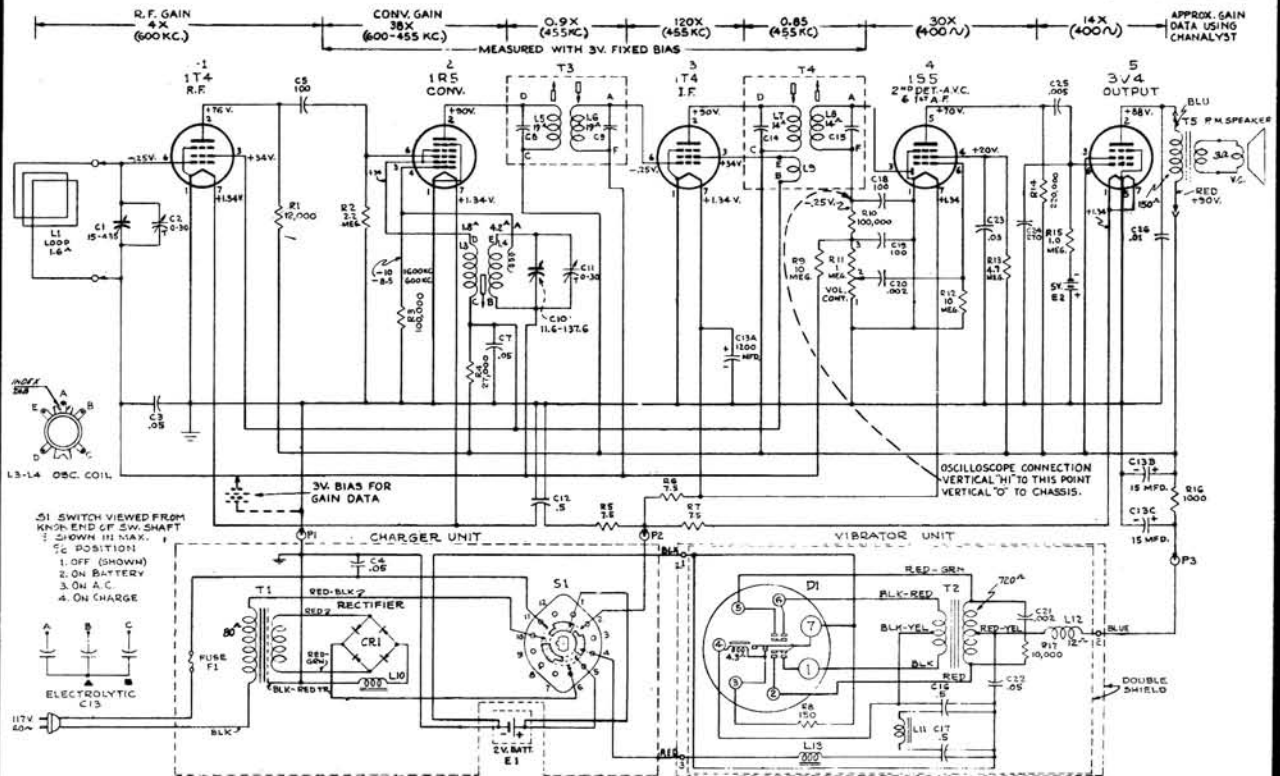

Cathode Ray Alignment is the preferable method. Connections for the oscilloscope are shown on the schematic diagram.

Output Meter Alignment.—If this method is used, connect the meter across the voice coil and turn the receiver volume control to maximum.

Test Oscillator.—For all alignment operations, connect the low side of the test oscillator to the receiver chassis and keep the oscillator output as low as possible to avoid AVC action.

Steps	Connect the high side of test-oscillator to—	Tune test-osc. to—	Turn radio dial to—	Adjust the following for max. peak output
1	High side of loop (Green lead) in series with 0.1 mfd.	455 kc	Gang at max. cap.	L7, L8, 2nd I.F. trans L5, L6, 1st I.F. trans.
2	220 mmf. in series with a single turn loop 4x8 in., approx. 3 in. from receiver loop.	1600 kc	1600 kc "C"	C11 Osc. C2 R.F.
3	(Bottom shield cover in place and chassis in cabinet)	600 kc	600 kc "B"	L4 Osc. Rock in
4		1600 kc	1600 kc "C"	C11 Osc.

Note.—In alignment, if possible, it is advisable to utilize an external source of "B" voltage. This will facilitate accessibility of the various trimmers.

Calibration.—It is not necessary to refer to the dial scale for calibration. Three reference marks on the dial backing arc used. With the gang completely meshed, the pointer should be set at "A" as shown in the diagram. For alignment purposes, 600 kc. will then fall at "B", and 1600 kc. will be at "C".

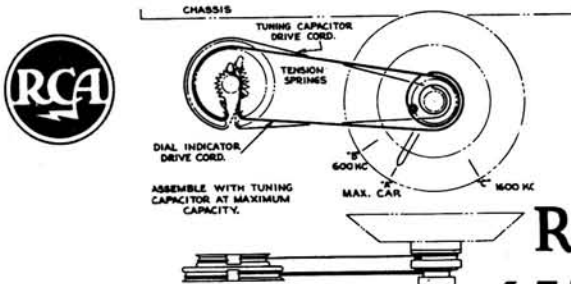

Operation.—This set operates on battery, or 117 Volt, 60 cycle AC (Battery in set, and in good condition). Provision is made so that when the set is operating on "AC" the battery is receiving a slight charge. In the "Charge" position, the rate of charge is much higher. A completely discharged battery will recharge in about 24 hours on "Charge". It is possible to overcharge the battery in the "AC" position, so it is advisable to play the receiver on "Battery" until slightly discharged whenever the battery has become fully charged on "AC".

Battery Charging.—With the cabinet back removed, two balls (1 red and 1 green) may be seen through an opening in the battery compartment cover. Both balls at top—battery full charged—Green ball sinks when battery is 20% discharged. Both balls at bottom—battery 90% discharged. Re-charge by connecting set to 115 volt 60 cycle power supply and set power switch to "CHG". Do not overcharge—check fuse if battery does not charge—do not allow battery to remain in discharged condition.

Water level.—Water Level should be checked frequently and distilled water or tap water, if it is used for cooking and drinking, added if required to bring liquid level up to the indicator line visible through the opening in the battery compartment cover. To add water; Remove line cord from power supply, remove cabinet back, remove thumb nuts and battery compartment cover, pull the battery out sufficiently to expose the red fill cap (pull on strap at bottom of battery), do not strain battery leads. Unscrew the red fill cap and add sufficient water to bring liquid level up to the indicator line.

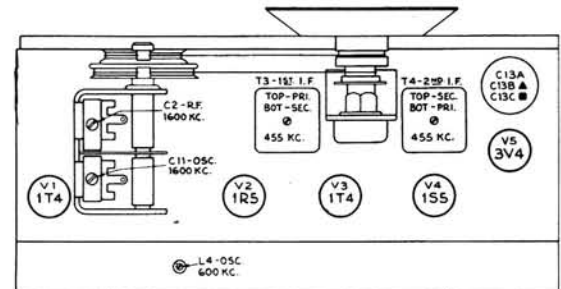

RCA VICTOR
65BR9 PORTABLE
Chassis No. RC-1045 145

MANUAL OF 1948 MOST-OFTEN-NEEDED RADIO DIAGRAMS

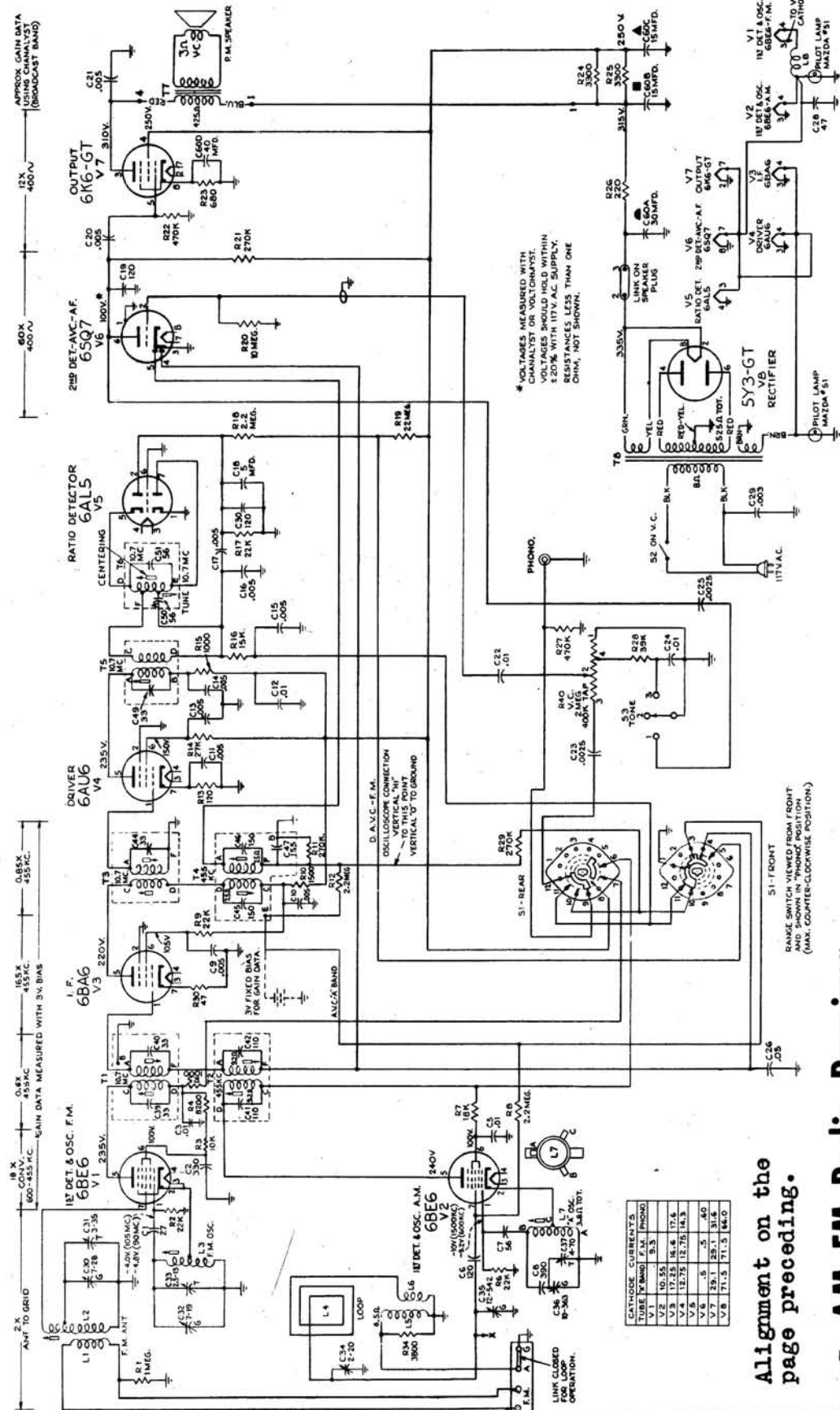

Alignment on the page preceding.

AM-FM Radio Receiver

Critical Lead Dress

1. Dress capacitor C-1 near chassis base.
2. Dress lead from pin No. 5, No. 1 6BE6 to terminal C. of transformer T1, as near the bottom of the FM shelf as possible.
3. Dress capacitor C-23 next to chassis.
4. The lead from capacitor C-23 to the high side of the volume control must be dressed next to chassis along front apron.
5. Dress resistor R-20 near chassis base.

Schematic Diagram

6. Dress all a-c leads away from volume control.
7. Solder FM antenna coil primary leads to terminal board with as short a lead length as practical.
8. Make all FM leads as short as possible. Dress of all other leads should be similar to original wiring.
9. The lead from pin No. 2, 6BA6, to ground must be dressed as close to the base and as near to the back apron as possible. This lead provides degeneration for the IF stage and neither its length, nor the point at which it is grounded to the chassis should be changed.

R C A VICTOR
Models 68R1, 68R2, 68R3, & 68R4
Chassis No. RC-608

MANUAL OF 1948 MOST-OFTEN-NEEDED RADIO DIAGRAMS

REGAL ELECTRONICS CORPORATION

NEW YORK, N. Y.

MODEL 1049

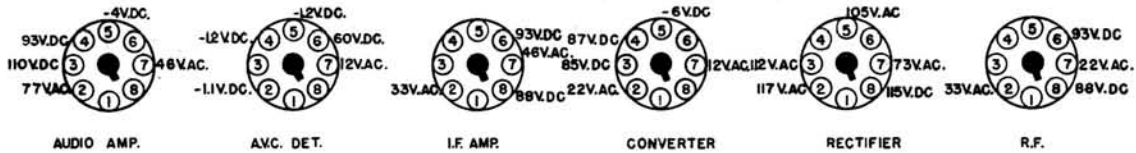
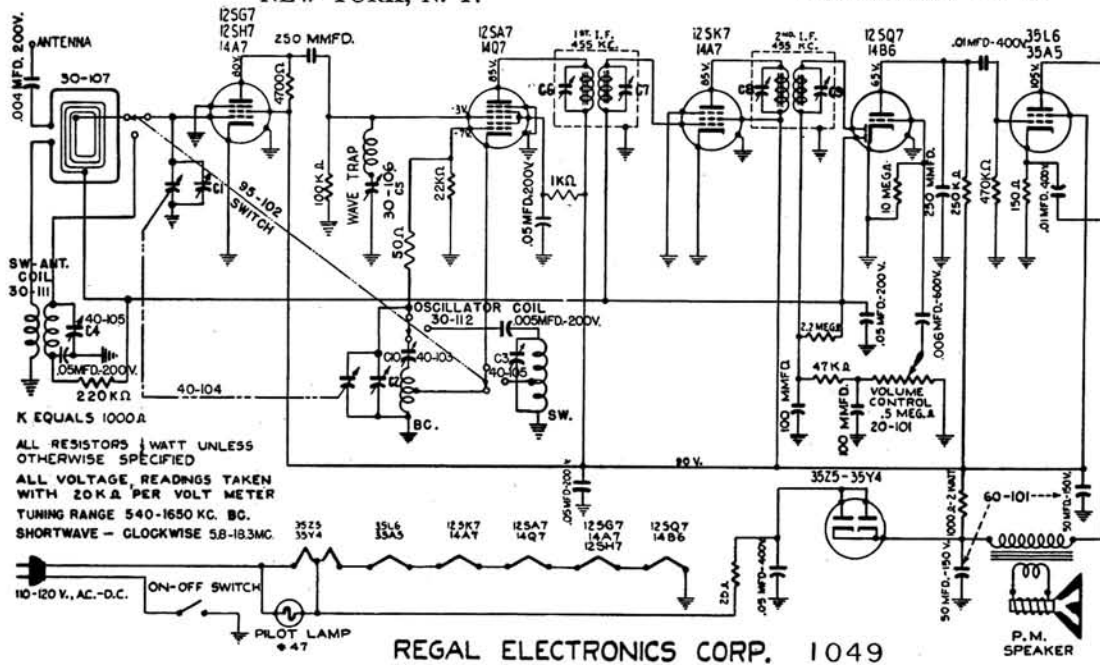

VOLTAGES TAKEN WITH 20KΩ PER VOLT METER WITH CHASSIS GROUND, AT 1000KC.

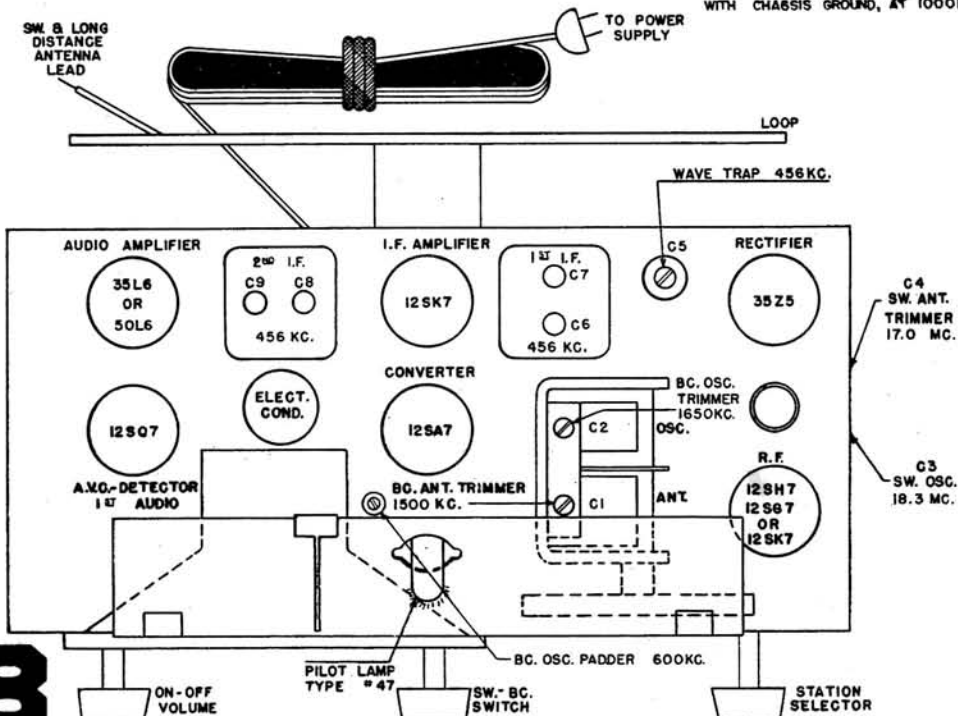

MANUAL OF 1948 MOST-OFTEN-NEEDED RADIO DIAGRAMS

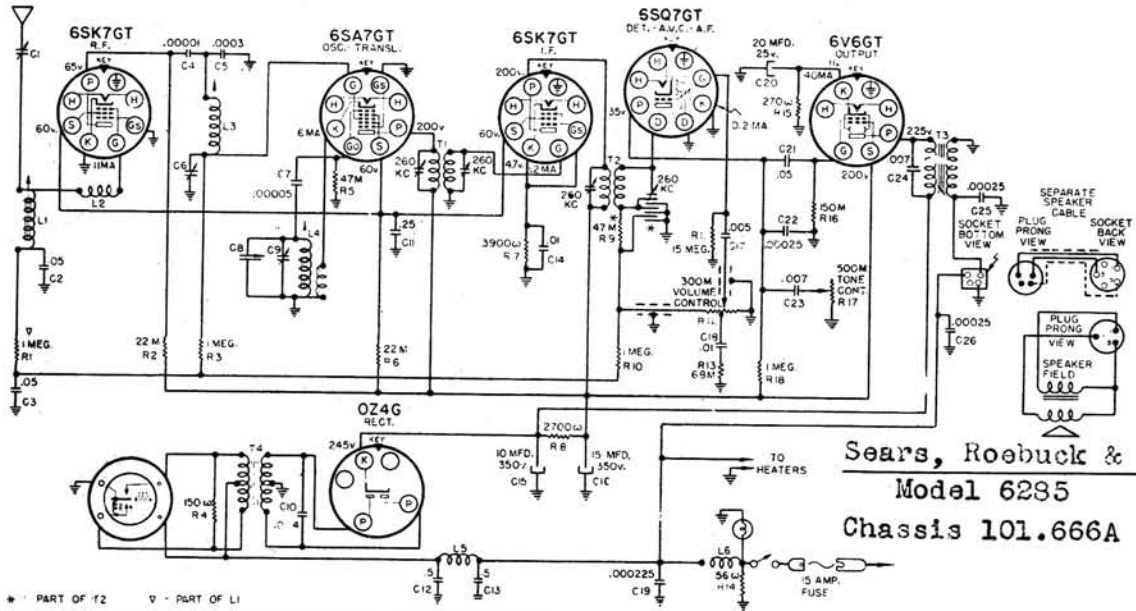

Sears, Roebuck & Co.
Model 6285
Chassis 101.666A

* - PART OF T2 ♀ - PART OF L1
TUBE SOCKETS ARE VIEWED FROM UNDER SIDE OF CHASSIS. VOLTAGE READINGS SHOWN AT SOCKET PRONGS ARE TO CHASSIS, AND ARE TAKEN WITH NO SIGNAL. WHERE NO READING IS GIVEN, THE VOLTAGE IS ZERO OR TOO LOW TO READ.

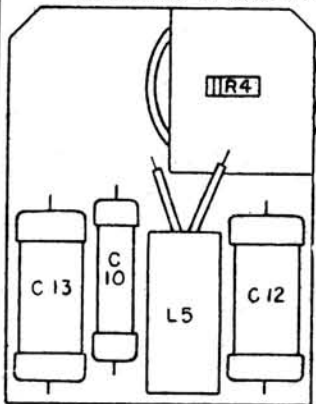

LOCATION OF PARTS UNDER POWER SUPPLY
101.666A-1B

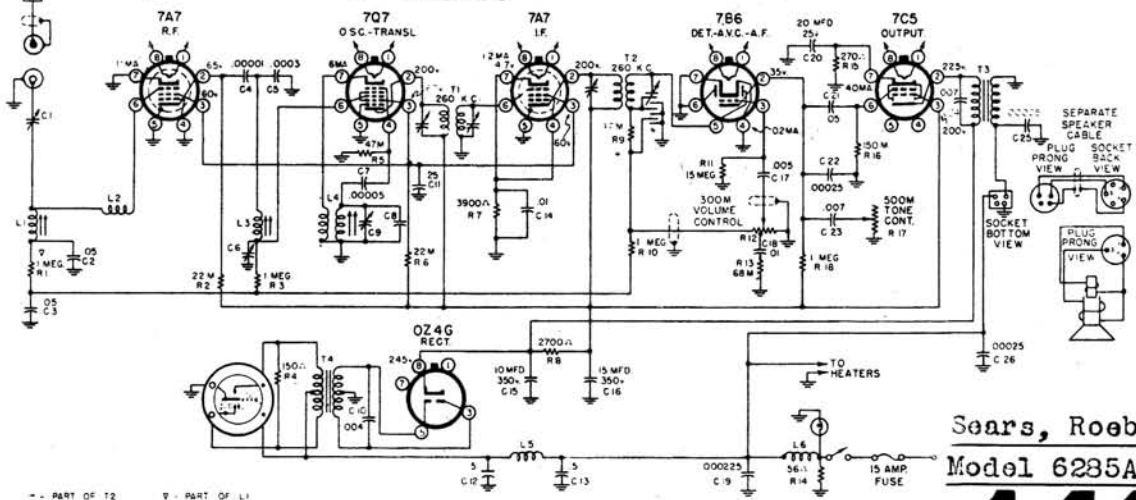
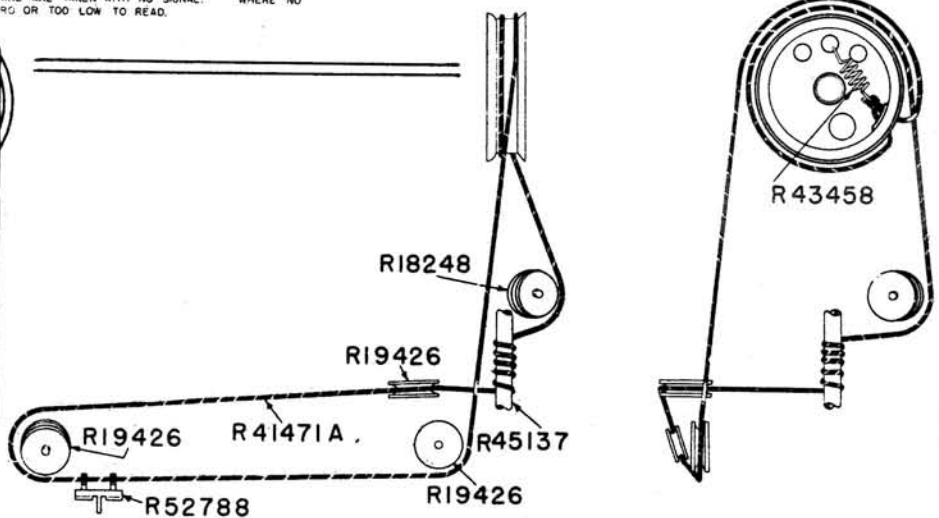

Sears, Roebuck
Model 6285A

* - PART OF T2 ♀ - PART OF L1
TUBE SOCKETS ARE VIEWED FROM UNDER SIDE OF CHASSIS. VOLTAGE READINGS SHOWN AT SOCKET PRONGS ARE TO CHASSIS, AND ARE TAKEN WITH NO SIGNAL. WHERE NO READING IS GIVEN, THE VOLTAGE IS ZERO OR TOO LOW TO READ.
"A" BATTERY - 6 VOLTS CURRENT DRAIN - 6.5 AMPERES

DIAGRAM 101.666-1B

MANUAL OF 1948 MOST-OFTEN-NEEDED RADIO DIAGRAMS

Sears, Roebuck & Co. Catalog Model 8000, Chassis 132.838

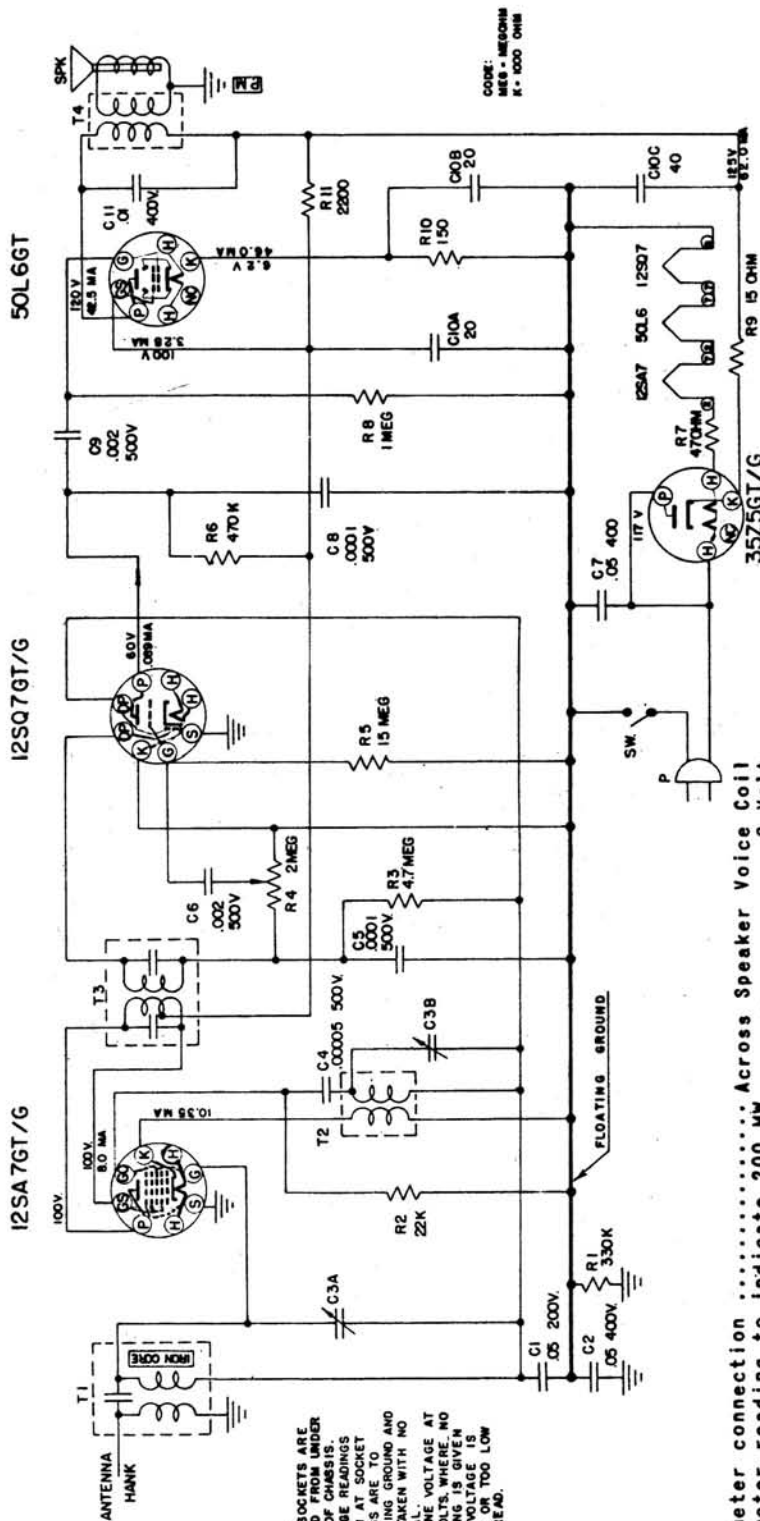

NOTE: TUBE SOCKETS ARE VIEWED FROM UNDER SIDE OF CHASSIS. VOLTAGE READINGS SHOWN AT SOCKET TERMINALS ARE TAKEN WITH NO SIGNAL. ARE TAKEN WITH NO SIGNAL. A.C. LINE VOLTAGE AT 117 VOLTS, WHERE NO READING IS GIVEN THE VOLTAGE IS LOW TO READ.

CODE: METERS OHM K=1000 OHM

Output meter connection Across Speaker Voice Coil
 Output meter reading to indicate 200 MW8 Volt
 Generator modulation 30% 400 Cycles
 Position of volume control Fully Clockwise
 Position of dial pointer with variable condenser fully closed Down

POSITION OF VARIABLE	GENERATOR FREQUENCY	DUMMY ANTIENNA	GENERATOR CONNECTION HIGH-SIDE	GENERATOR CONNECTION LOW-SIDE	ADJUST TRIMMERS IN-ORDER-SHOWN	TRIMMER FUNCTION
Open	455 KC	.05 Mfd.	Mixer Grid	Floating Gnd T3		IF
Open	1620 KC	50 Mmf.	*Ant. Lug	Float. Gnd. C38		Oscillator
1400 KC	1400 KC	50 Mmf.	*Ant. Lug	Float. Gnd. C3A		Antenna
600 KC	600 KC	50 Mmf.	*Ant. Lug	Float. Gnd. **Check Point		Antenna

* Antenna hank lug on antenna coil with hank removed.
 ** Check sensitivity at 600 KC. If low, adjust antenna section plates of variable for maximum output at 600 KC.
 The alignment procedure should be repeated in the original order for greatest accuracy. Always keep the output from the signal generator at its lowest possible value to make the A. V. C. action of the receiver ineffective.

PART NO.	DESCRIPTION
R1	Resistor, 150,000 Ohms, 1/4 Watt
R2	Resistor, 22K, 1/4 Watt
R3	Resistor, 4.7 MEG, 1/4 Watt
R4	Resistor, 2 MEG, 1/4 Watt
R5	Resistor, 15 MEG, 1/4 Watt
R6	Resistor, 470K, 1/4 Watt
R7	Resistor, 470 Ohms, 1/4 Watt
R8	Resistor, 1 MEG, 1/4 Watt
R9	Resistor, 15 Ohms, 1/4 Watt
R10	Resistor, 150 Ohms, 1/4 Watt
R11	Resistor, 2200 Ohms, 1/4 Watt
C1	Capacitor, .05 Mfd., 250 V
C2	Capacitor, .05 Mfd., 500 V
C3	Capacitor, .0005 Mfd., 500 V
C4	Capacitor, .0005 Mfd., 500 V
C5	Capacitor, .0001 Mfd., 500 V
C6	Capacitor, .002 Mfd., 500 V
C7	Capacitor, .05 Mfd., 117 V
C8	Capacitor, .0001 Mfd., 500 V
C9	Capacitor, .002 Mfd., 500 V
C10	Capacitor, .002 Mfd., 500 V
C11	Capacitor, .01 Mfd., 100 V
T1	Transformer, 117 Volt, 25 Volt
T2	Transformer, 117 Volt, 25 Volt
T3	Transformer, 117 Volt, 25 Volt
T4	Transformer, 117 Volt, 25 Volt
25A7	Tube, 25A7
50L6	Tube, 50L6
12SQ7	Tube, 12SQ7
12SA7	Tube, 12SA7
SPK	Speaker, 8" P.H.
SW	Switch, 117 Volt

MANUAL OF 1948 MOST-OFTEN-NEEDED RADIO DIAGRAMS

Sears, Roebuck & Co.
Catalog Models 7086 & 7103
Chassis 110.466, 110.466-1

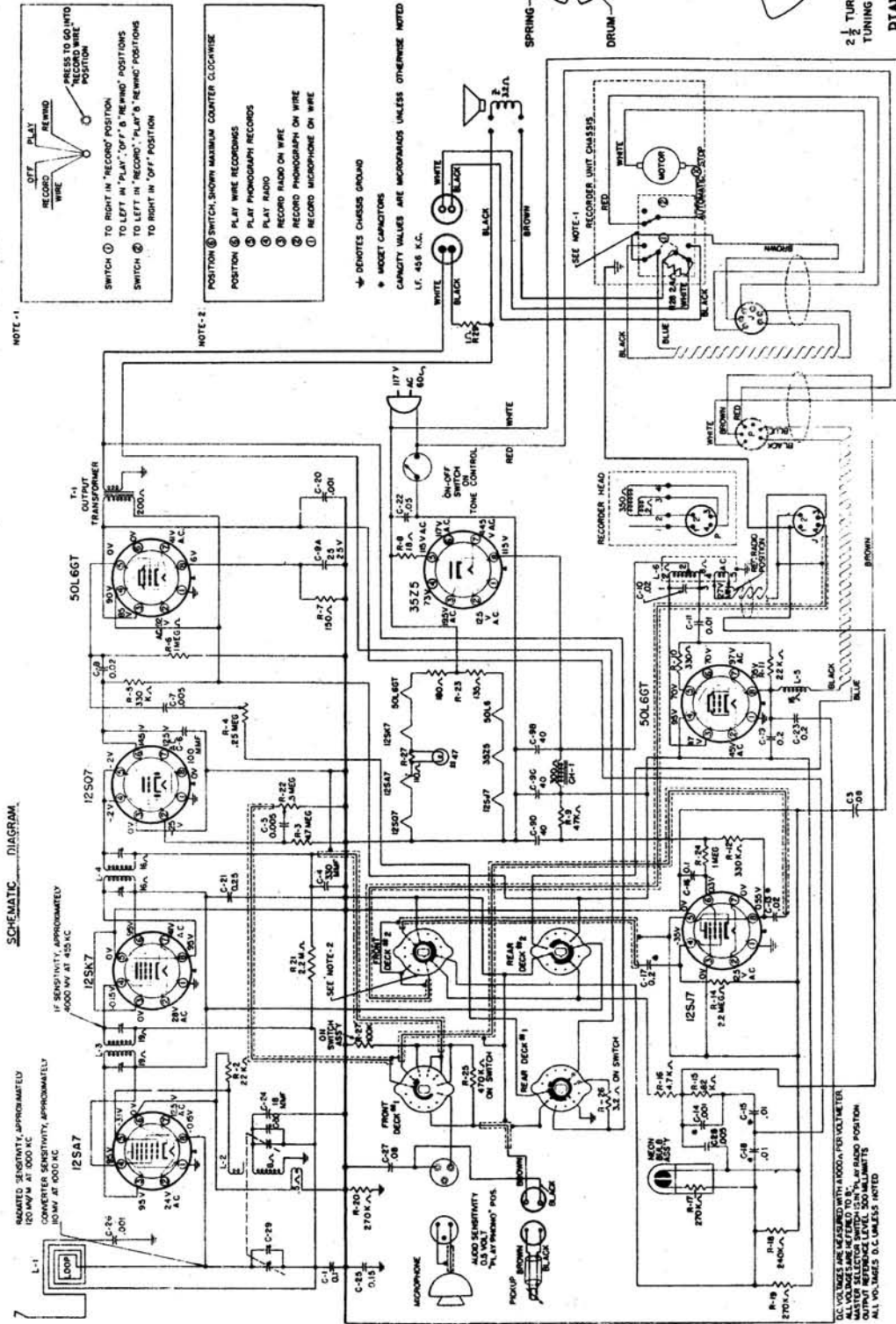

SCHMATIC DIAGRAM

POSITION OF VARIABLE	GENERATOR FREQUENCY	DUMMY ANTENNA	GENERATOR CONNECTION	ADJUSTMENTS (In order shown)	FUNCTION
Any	455	.2 mfd.	Grid. 128A7GT	L3, L4	I.F.
1500 Kc	1500 Kc	***	*** See Note Below	030, 029	Geo. R. F.
500 Kc	500 Kc	***	*** See Note Below (Check-Point)		(Check Point)

Sears, Roebuck & Co.
Catalog Models 7086 & 7103
Chassis 110.466, 110.466-1

***Run a wire from the output terminal of generator near the receiver. No connection is made between the signal generator and the receiver.

MANUAL OF 1948 MOST-OFTEN-NEEDED RADIO DIAGRAMS

Sears, Roebuck & Co.

Catalog Nos. 7165, 7166
Chassis 101.823, -1, -A

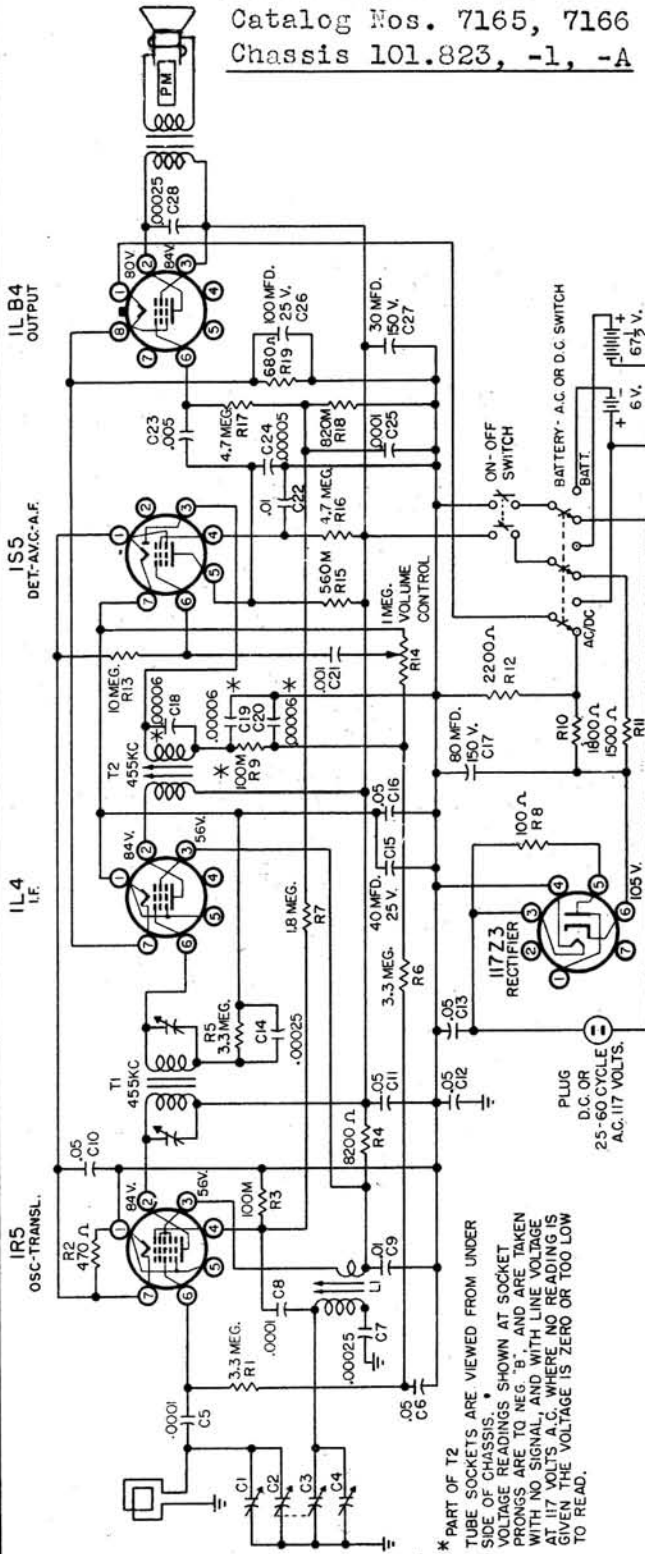

Sears, Roebuck & Co.

Catalog Nos. 7020, 7021
Chassis 101.807, -A

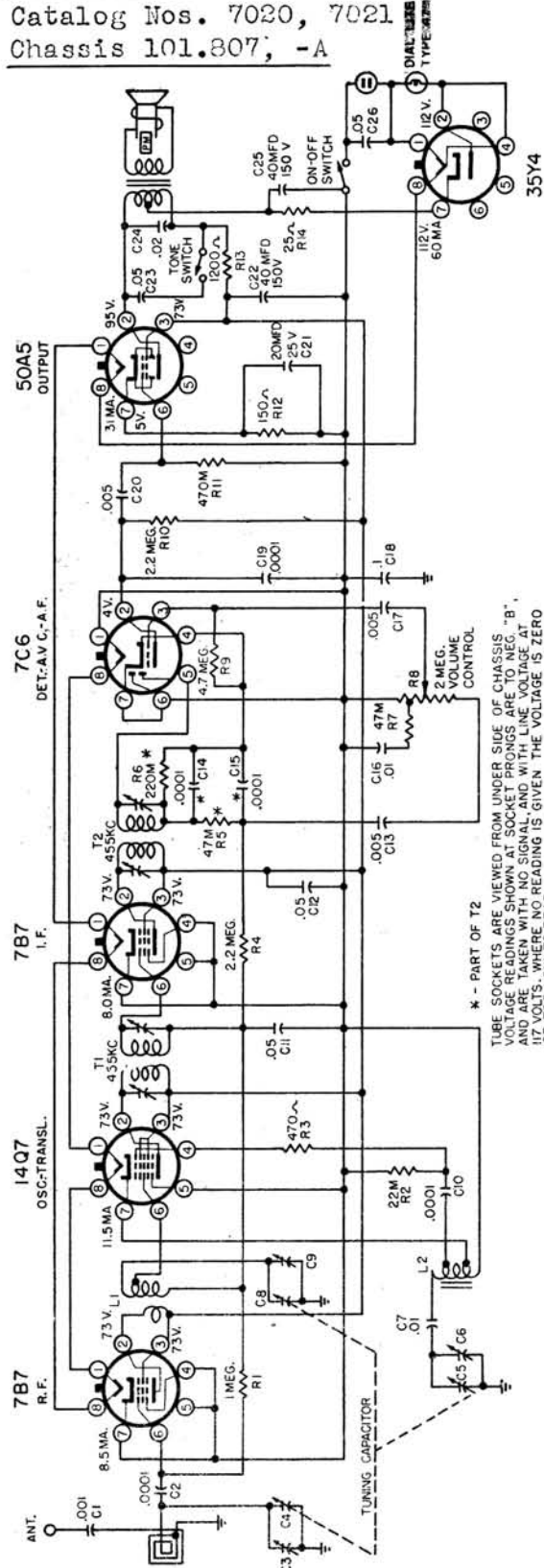

MANUAL OF 1948 MOST-OFTEN-NEEDED RADIO DIAGRAMS

Sears, Roebuck & Co.
Model 8150, Chassis 109.634

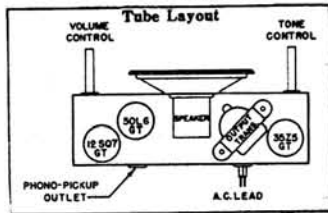
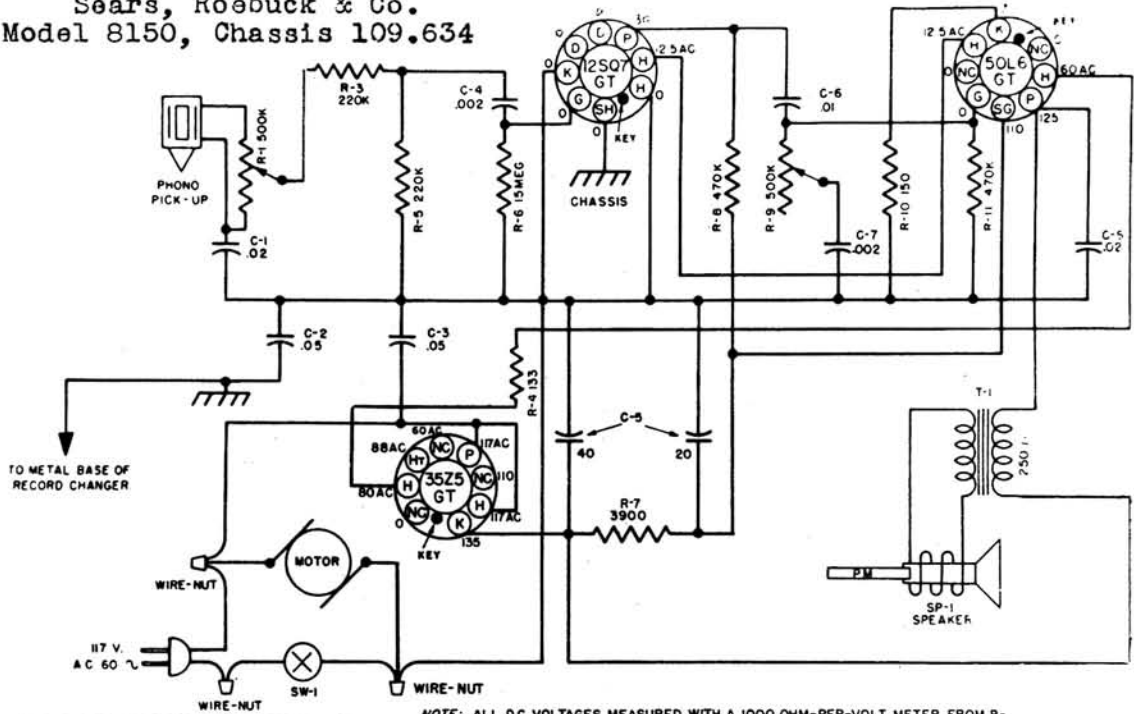

NOTE:- ALL D.C. VOLTAGES MEASURED WITH A 1000 OHM-PER-VOLT METER FROM B- TO SOCKET CONTACT INDICATED. ALL VOLTAGES ARE POSITIVE D.C. UNLESS OTHERWISE MARKED.
VOLUME CONTROL FULL ON. ZERO SIGNAL INPUT.
TONE CONTROL IN CLOCKWISE POSITION.
LINE VOLTAGE 117 VOLTS A.C.
RESISTANCE VALUES ARE IN OHMS UNLESS OTHERWISE NOTED.
"K" EQUALS 1000 OHMS, "MEG" EQUALS 1,000,000 OHMS.
CAPACITY VALUES ARE IN MICROFARADS UNLESS OTHERWISE NOTED.
ALL TUBE SOCKETS ARE SHOWN FROM PIN END VIEW.

Sears, Roebuck & Co. Catalog No. 8144, Chassis 431.199

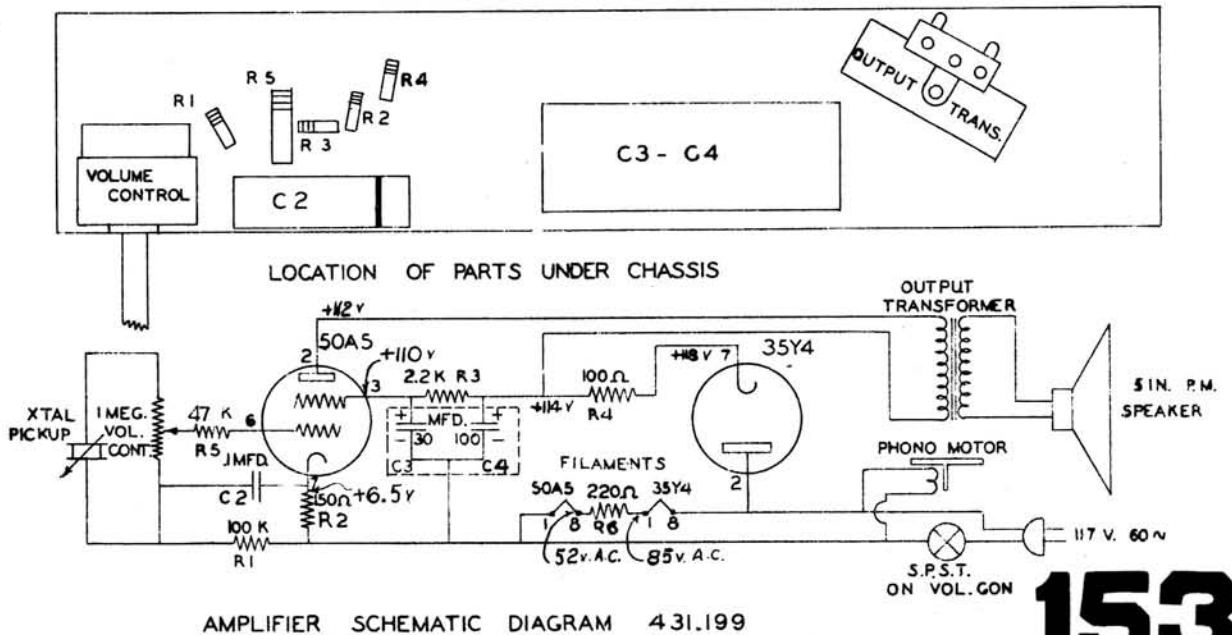

AMPLIFIER SCHEMATIC DIAGRAM 431.199

MANUAL OF 1948 MOST-OFTEN-NEEDED RADIO DIAGRAMS

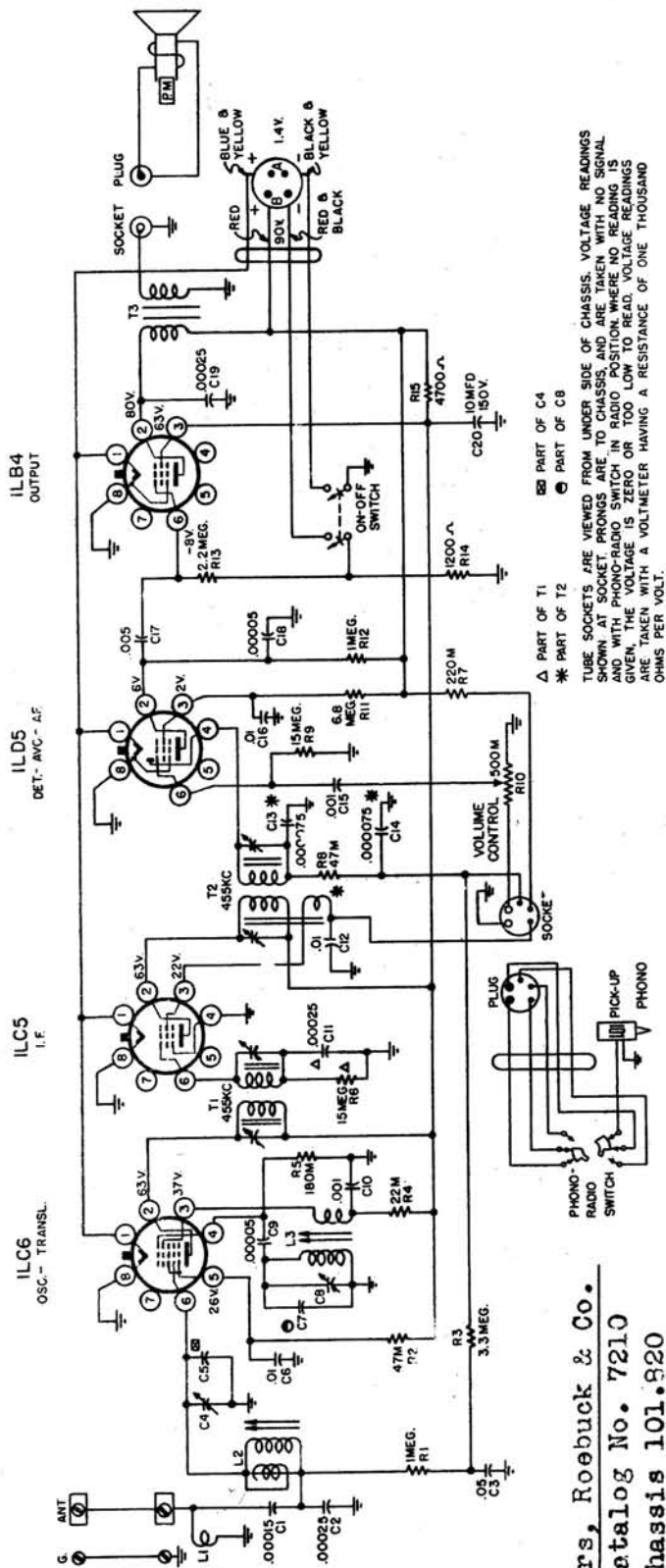

Output Meter Connection.....Across loud-speaker voice coil
 Output Meter Reading to Indicate 50 Milliwatts (Standard Output).....0.4 volt
 Generator Ground Lead Connection.....Receiver chassis
 Dummy Antenna Value to be in Series with Generator Output.....See chart below
 Connection of Generator Output Lead.....See chart below
 Generator Modulation.....30%, 400 cycles
 Position of Volume Control.....Fully on
 Position of Pointer with Tuner Fully Closed.....Line to the left of 540 Kc calibration mark

Sears, Roebuck & Co.
 Catalog No. 7210
 Chassis 101.920

POSITION OF TUNER	GENERATOR FREQUENCY	DUMMY ANTENNA	GENERATOR CONNECTION	ADJUSTMENTS (IN ORDER SHOWN)	FUNCTION
Closed	455 Kc.	.1 mfd. 1106 Transl. Grid	T2, T3	I.F.	Oscillator
1725	1725 Kc.	.000075 mfd.	Ant. Terminal	C8	Antenna
1725	1725 Kc.	.000075 mfd.	Ant. Terminal	C4	Oscillator
1500	1500 Kc.	.000075 mfd.	Ant. Terminal	L3	Antenna
1500	1500 Kc.	.000075 mfd.	Ant. Terminal	L2	Antenna
1725	1725 Kc.	.000075 mfd.	Ant. Terminal	C8, C4	Osc. & Ant. Recheck

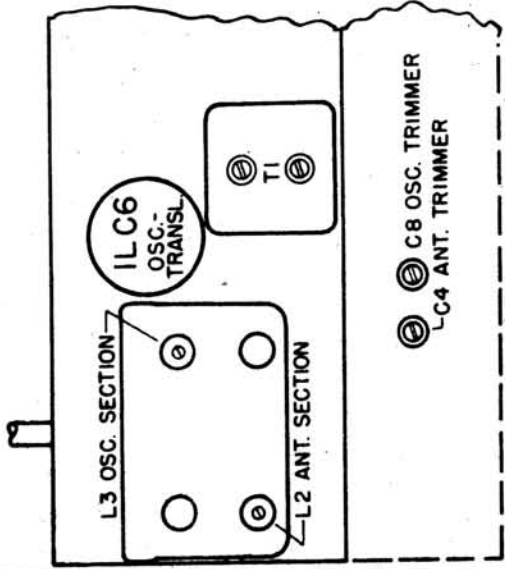

MANUAL OF 1948 MOST-OFTEN-NEEDED RADIO DIAGRAMS

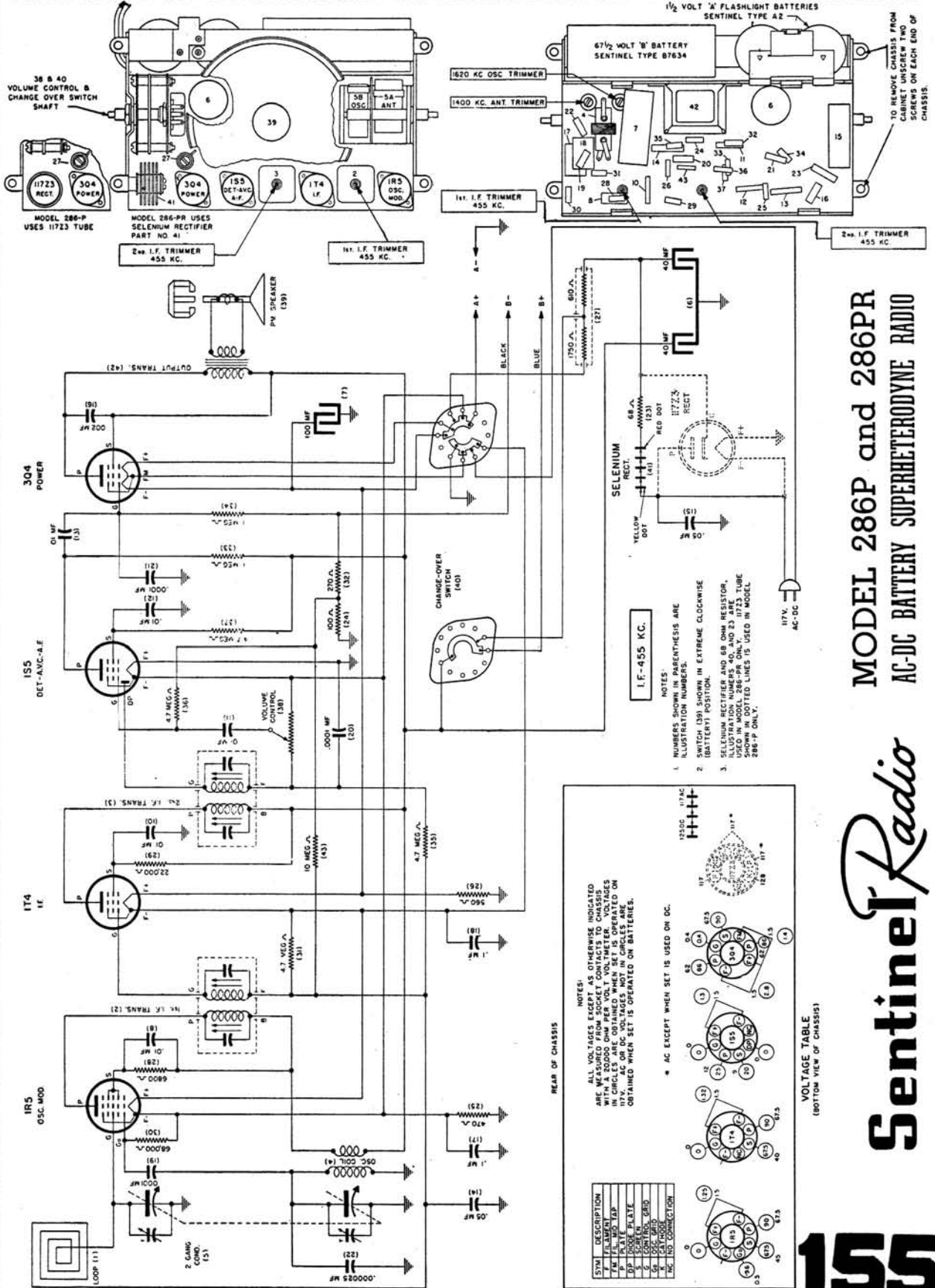

38 & 40
VOLUME CONTROL &
CHANGE OVER SWITCH
SHAFT

MODEL 286-P
USES 11723 TUBE

MODEL 286-PR USES
SELENIUM RECTIFIER
PART NO. 41

1620 KC OSC TRIMMER

1400 KC ANT TRIMMER

1st. I.F. TRIMMER
455 KC.

2nd. I.F. TRIMMER
455 KC.

1st. I.F. TRIMMER
455 KC.

2nd. I.F. TRIMMER
455 KC.

1½ VOLT 'A' FLASHLIGHT BATTERIES
SENTINEL TYPE A2

67½ VOLT 'B' BATTERY
SENTINEL TYPE B7634

TO REMOVE CHASSIS FROM
CABINET UNSCREW TWO
SCREWS ON EACH END OF
CHASSIS.

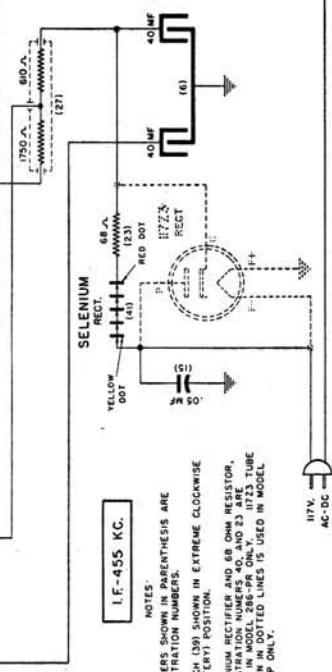

SELENIUM
RECT.

17723
RECT.

68 Ω

21723
TUBE

117V.
AC-DC

NOTES:

1. NUMBERS SHOWN IN PARENTHESIS ARE ILLUSTRATION NUMBERS.

2. SWITCH (39) SHOWN IN EXTREME CLOCKWISE (BRIGHT) POSITION.

3. SELENIUM RECTIFIER AND 68 OHM RESISTOR, USED IN MODEL 286-PR ONLY. IN MODEL 286-P ONLY.

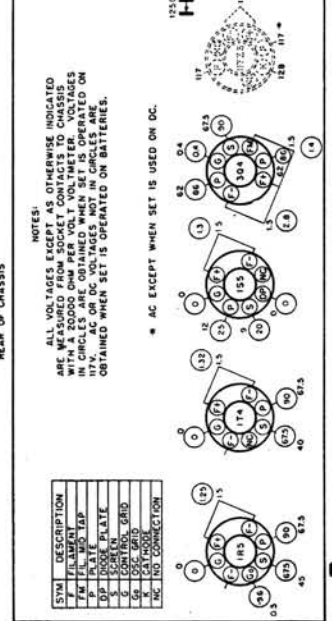

REAR OF CHASSIS

NOTES:

ARE ALL VOLTAGES EXCEPT AS OTHERWISE INDICATED IN CIRCLES. VOLTAGES IN CIRCLES ARE OBTAINED WHEN SET IS OPERATED ON BATTERIES. VOLTAGES IN SQUARES ARE OBTAINED WHEN SET IS OPERATED ON BATTERIES.

* AC EXCEPT WHEN SET IS USED ON DC.

MODEL 286P and 286PR

AC-DC BATTERY SUPERHETERODYNE RADIO

SentinelRadio

VOLTAGE TABLE
(BOTTOM VIEW OF CHASSIS)

155

Sentinel Radio MODELS 293-CT and 1U-293-CT

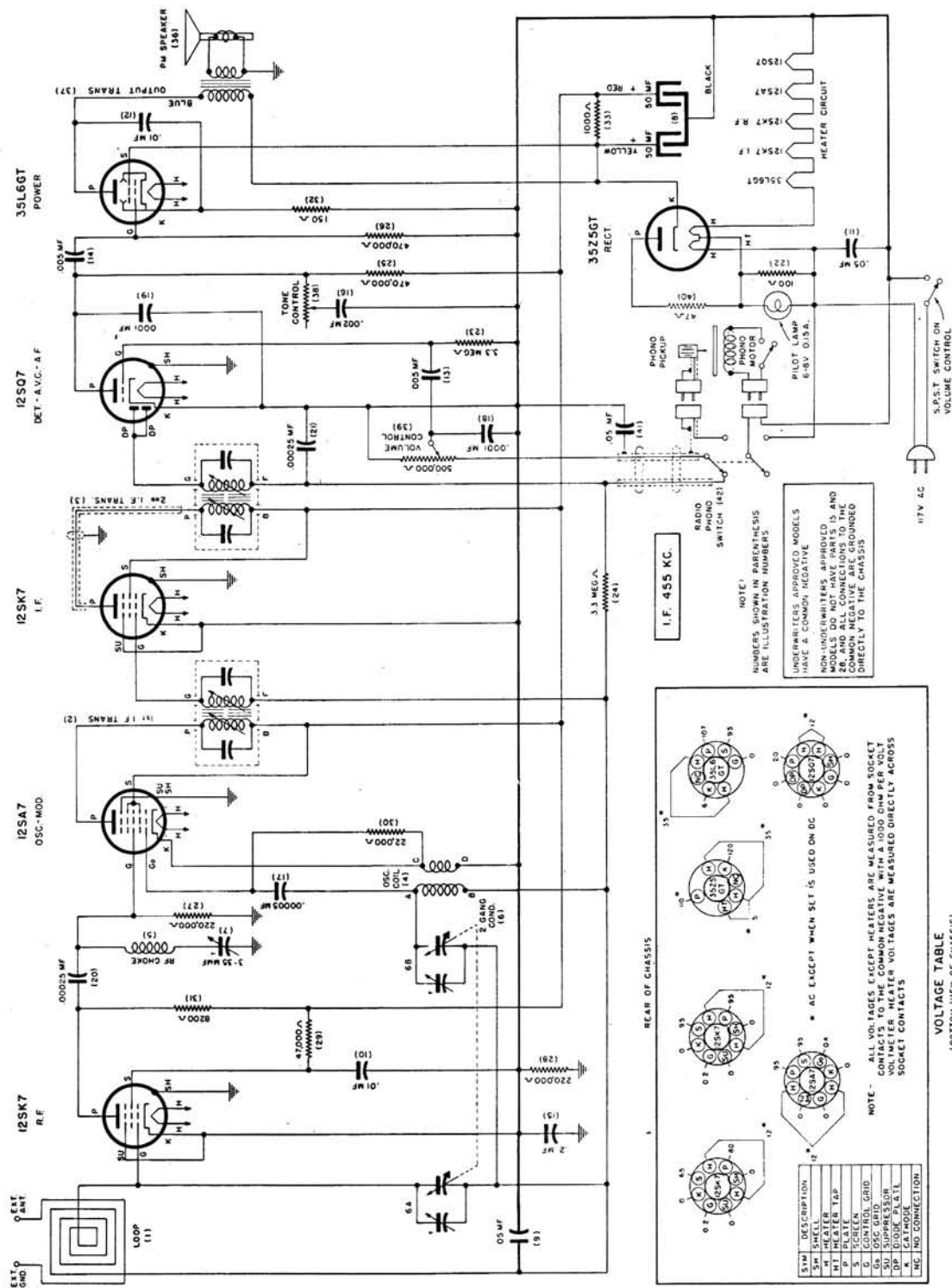

MANUAL OF 1948 MOST-OFTEN-NEEDED RADIO DIAGRAMS

Sentinel Radio MODELS 293-CT and 1U-293-CT

ALIGNMENT PROCEDURE

For Alignment procedure read tabulations from left to right, and make the adjustment marked (1) first, (2) next, (3) third. **IMPORTANT: BEFORE ALIGNING, PLACE LOOP ANTENNA IN THE SAME POSITION IT WILL BE IN WHEN THE SET IS IN THE CABINET. BE SURE THAT IT DOES NOT MOVE WHILE ALIGNING.**

When adjusting 1650 kilocycle oscillator trimmer, 455 K.C. R.F. trimmer and 1400 kilocycle antenna trimmer, connect test oscillator to loop external antenna and ground connections with a .0002 Mfd. condenser in series with antenna lead.

Steps	TEST OSCILLATOR			Refer to parts layout diagram for location of trimmers mentioned below:
	Set receiver dial to:	Adjust test oscillator frequency to:	Use dummy antenna in series with output of test oscillator consisting of:	
	Any point where no interfering signal is received	Exactly 455 K. C.	0.2 Mfd. Condenser	Adjust each of the 2nd I.F. transformer trimmer adjustment screws for maximum output, then adjust each of the 1st I.F. transformer trimmer adjustment screws for maximum output.
1	Rotate gang condenser to maximum capacity	Exactly 455 K. C.	.0002 Mfd. Condenser	Adjust R. F. coil trimmer for <u>minimum</u> 455 K. C. signal.
2	Rotate gang condenser to minimum capacity	Exactly 1650 K. C.	.0002 Mfd. Condenser	Adjust 1650 K. C. oscillator trimmer for maximum output.
3	Approximately 1400 K. C.	Approx. 1400 K. C.	.0002 Mfd. Condenser	Adjust 1400 K. C. antenna trimmer for maximum output.

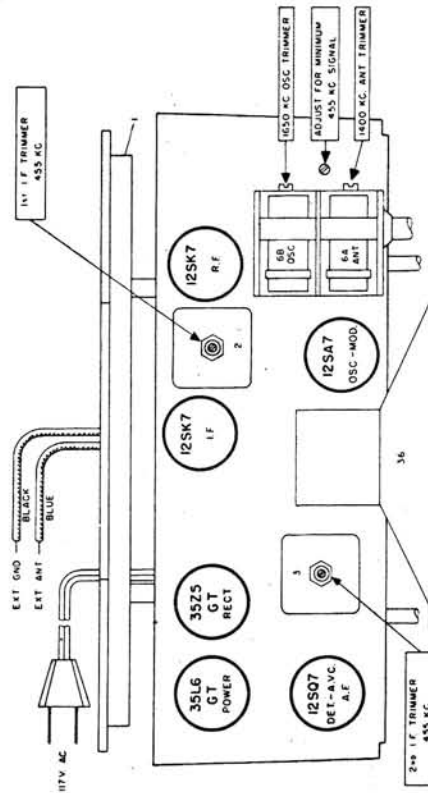
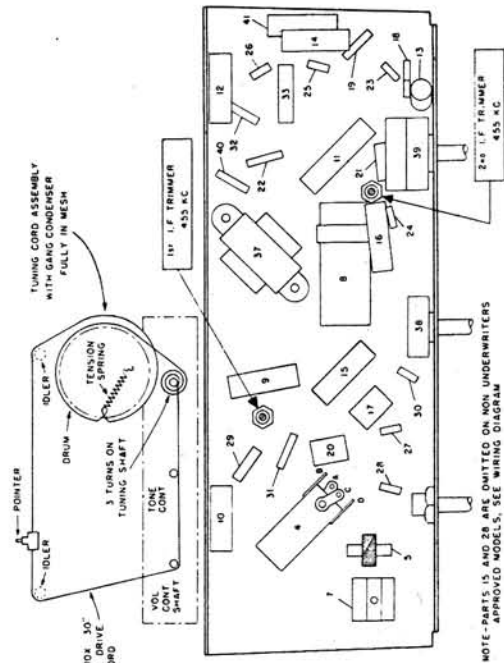

MANUAL OF 1948 MOST-OFTEN-NEEDED RADIO DIAGRAMS

McMurdo Silver Company
INCORPORATED

MODEL 906 AM/FM SIGNAL GENERATOR

C1 - 10/210 mmfd. air capacitor
 C2, C2a - 3/30 mmfd. air capacitors
 C3 - 50 mmfd. tubular ceramic $\pm 20\%$
 C4a, C4b - .1 mfd., 400 volt, $\pm 20\%$
 C5a thru C5e - 500 mmfd. ceramic $\pm 20\%$
 C6, C6a - 500 mmfd. ceramic $\pm 2\%$
 C7a thru C7c - .02 mfd., 400 volt, $\pm 20\%$
 C8, C8a - .05 mfd., 400 volt $\pm 20\%$
 C9 thru C9c - 8 mfd., 350 v. elect. $\pm 20\%$
 C10, C10a - .005 mfd. mica, $\pm 20\%$
 C11 thru C11c - .05 mfd., 200 v. $\pm 20\%$
 C12 - 20 mmfd. tubular ceramic $\pm 20\%$

R1, R1c - 20 K Ω 1/2 watt, $\pm 20\%$
 R2, R2a - 5 K Ω 1/2 watt, $\pm 20\%$
 R3 - 130 Ω 1/2 watt, $\pm 5\%$
 R4 thru R4b - 30 Ω 1/2 watt, $\pm 5\%$
 R5 - 510 Ω 1/2 watt, $\pm 20\%$
 R6 thru R6b - 1.5 K Ω 1/2 watt, $\pm 20\%$

R7 thru R7b - 33 Ω 1/2 watt, $\pm 5\%$
 R8 - 220 K Ω 1 watt, $\pm 20\%$
 R8a - 220 K Ω 1/2 watt, $\pm 20\%$
 R9 - 43 K Ω 1/2 watt, $\pm 20\%$
 R10 thru R10f - 100 K Ω 1/2 watt, $\pm 20\%$
 R11, R11a - 800 K Ω 1/2 watt, $\pm 1\%$
 R12, R12a - 270 K Ω 1/2 watt, $\pm 20\%$
 R13 thru R13b - 270 Ω 1/2 watt, $\pm 5\%$
 R14, R14a - 2 K Ω 2 watt, $\pm 20\%$
 R15, R15a - 500 K Ω 1/2 watt, $\pm 20\%$
 R16 - 3 Ω 2 watt, $\pm 20\%$

S 6 - Mazda S6 lamp

P1 - 125 molded potentiometer
 P2-S2 - 30 K Ω molded potentiometer
 P3 - 30 K Ω molded potentiometer
 P4, P4a - 3 K Ω w.w. potentiometer

L5, L5a - 8H., 40 MA. reactor

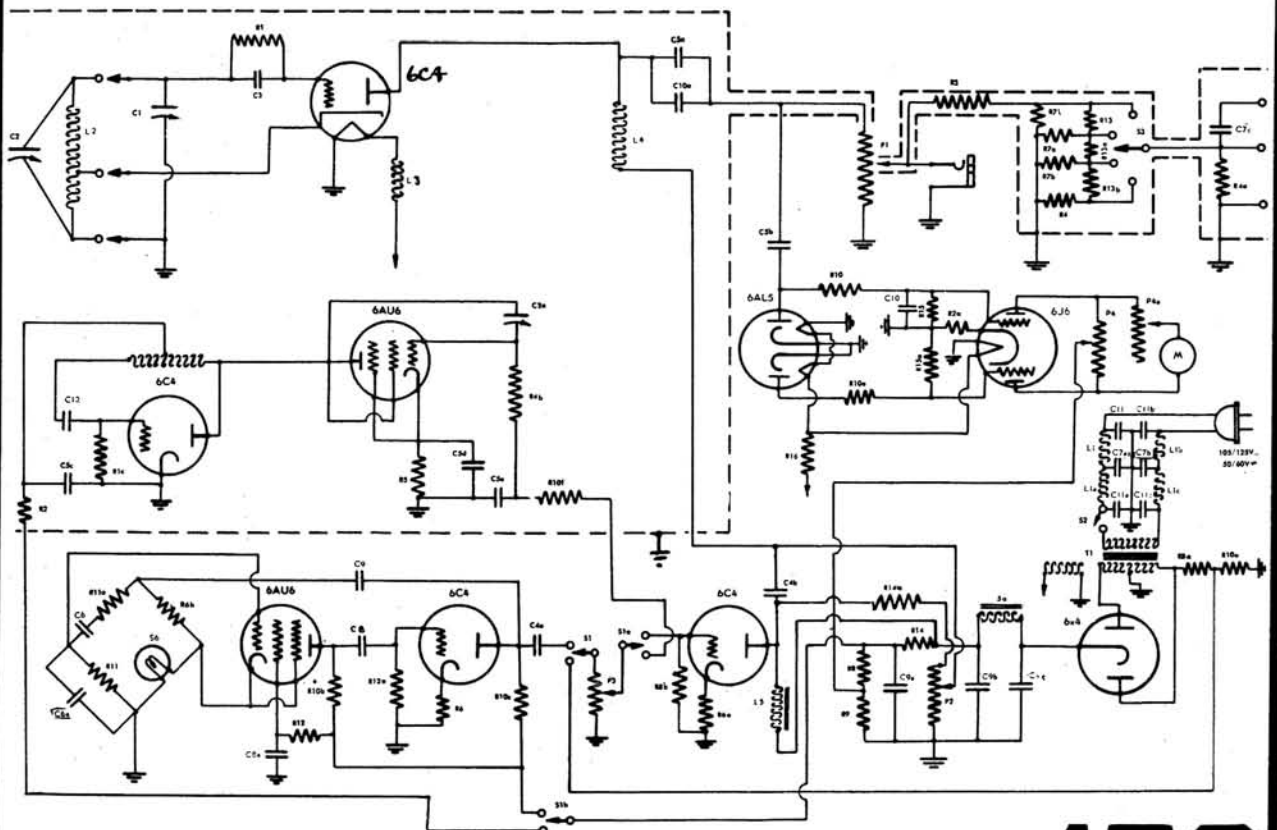

MANUAL OF 1948 MOST-OFTEN-NEEDED RADIO DIAGRAMS

Sonora

Clear as a Bell

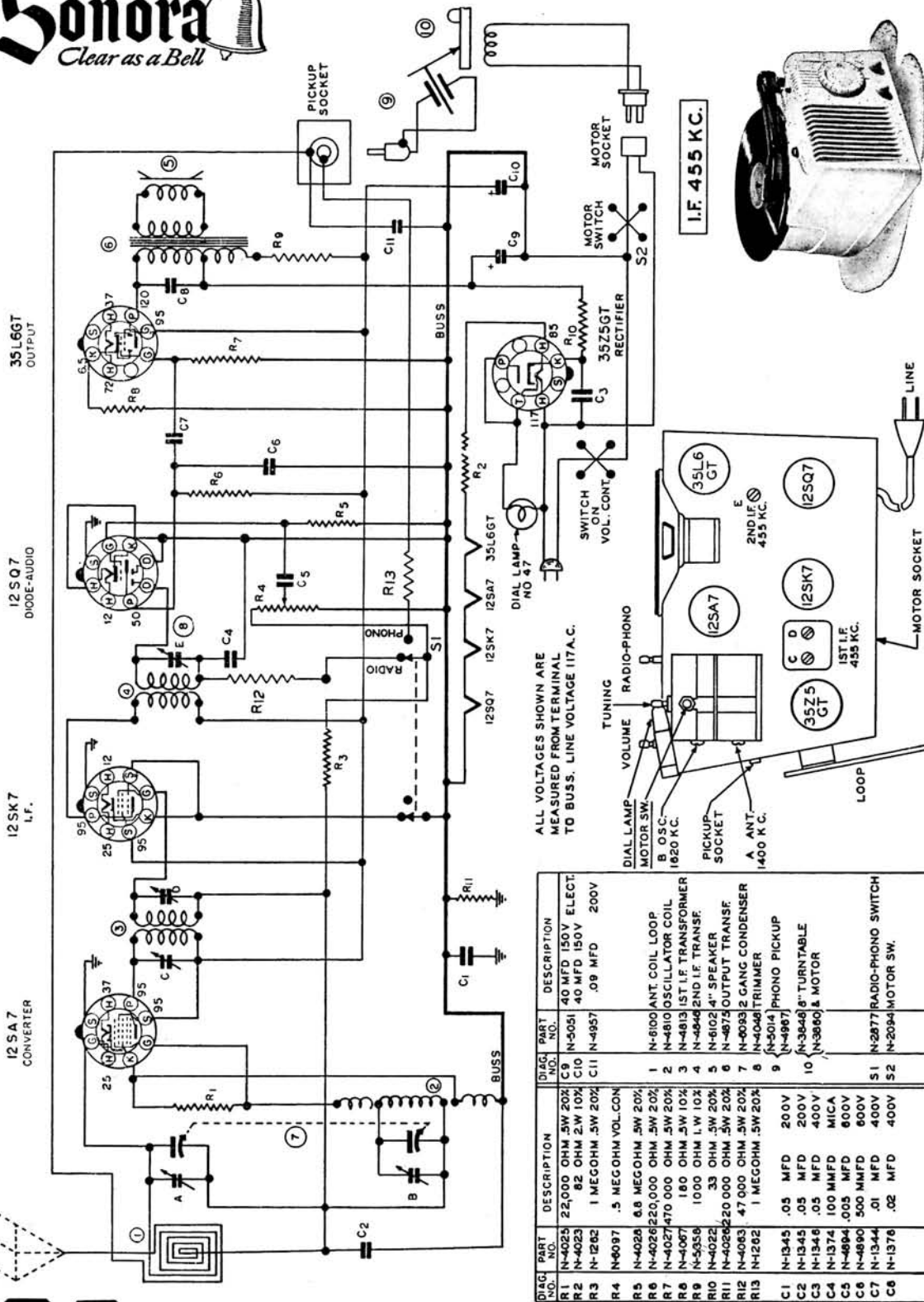

Model WGFU-241.

FIG. NO.	PART NO.	DESCRIPTION	VAL.	PART NO.	DESCRIPTION
R1	N-4025	22,000 OHM .5W 20%		C9	40 MFD 150V ELECT.
R2	N-4023	82 OHM 2W 10%		C10	40 MFD 150V ELECT.
R3	N-1262	1 MEG OHM .5W 20%		C11	.09 MFD 200V
R4	N-4097	.5 MEG OHM VOL. CON.			
R5	N-4026	6.8 MEG OHM .5W 20%		1	N-8100 ANT. COIL LOOP
R6	N-4026	220,000 OHM .5W 20%		2	N-4810 OSCILLATOR COIL
R7	N-4027	470 OHM .5W 20%		3	N-4813 1ST I.F. TRANSFORMER
R8	N-4067	180 OHM .5W 10%		4	N-4846 2ND I.F. TRANSF.
R9	N-5358	1000 OHM 1W 10%		5	N-8102 4" SPEAKER
R10	N-4025	33 OHM .5W 20%		6	N-4875 OUTPUT TRANSF.
R11	N-4026	220,000 OHM .5W 20%		7	N-0093 2 GANG CONDENSER
R12	N-4063	47,000 OHM .5W 20%		8	N-4048 TRIMMER
R13	N-1262	1 MEG OHM .5W 20%		9	N-5014 PHONO PICKUP
C1	N-1345	.05 MFD 200V		10	N-3848 8" TURNTABLE
C2	N-1345	.05 MFD 200V			
C3	N-1346	.05 MFD 400V			
C4	N-1374	100 MMFD MICA			
C5	N-4884	.005 MFD 600V			
C6	N-4890	500 MMFD 600V			
C7	N-1344	.01 MFD 400V			
C8	N-1376	.02 MFD 400V			

MANUAL OF 1948 MOST-OFTEN-NEEDED RADIO DIAGRAMS

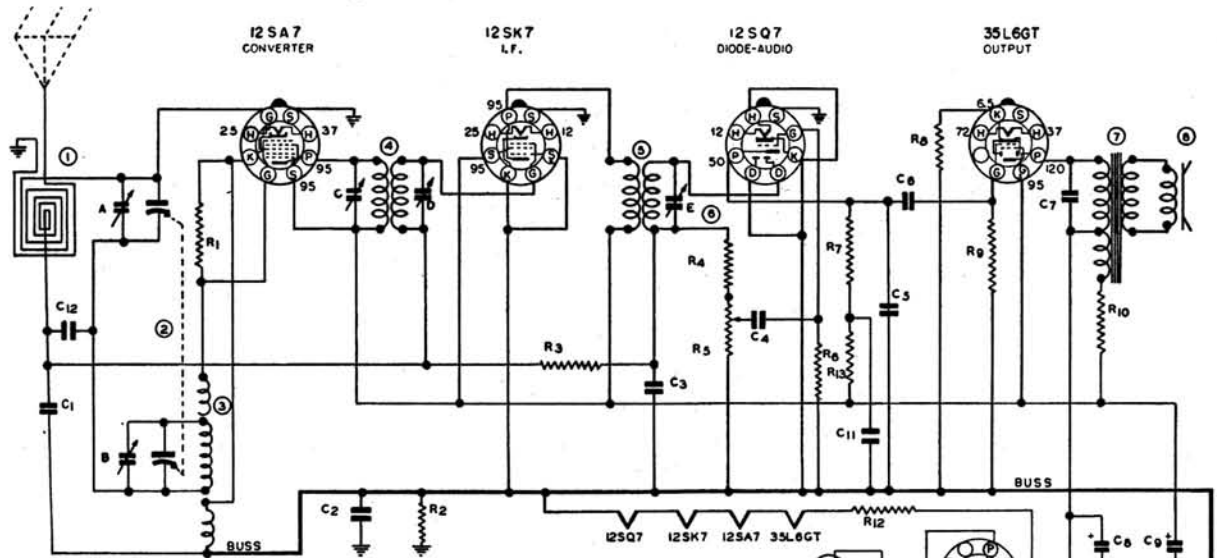

DIA. PART NO.	DESCRIPTION	DIA. PART NO.	DESCRIPTION
R1 N-4025	22,000 OHM .5W 20%	C6 N-1344	.01 MFD 400V 20%
R2 N-4026	220,000 OHM .5W 20%	C7 N-1376	.02 MFD 400V 20%
R3 N-1262	1 MEGOHM .5W 20%	C8 N-9051	40 MFD 150V ELECTRO
R4 N-4063	47,000 OHM .5W 20%	C9 N-1376	40 MFD 150V LYTC
R5 N-2067	.5MEG. VOLUME CONTROL	C10 N-1376	.05 MFD 400V 20%
R6 N-4028	6.8 MEGOHM .5W 20%	C11 N-1351	.1 MFD 200V 20%
R7 N-4026	220,000 OHM .5W 20%	C12 N-1345	.05 MFD 200V 20%
R8 N-4067	180 OHM .5W 10%	1 N-6188	LOOP COIL
R9 N-4027	470,000 OHM .5W 20%	2 N-6192	2 GANG CONDENSER
R10 N-5356	1,000 OHM 1W 10%	3 N-4845	OSC. COIL
R11 N-4022	33 OHM .5W 20%	4 N-4813	1ST I.F. TRANSFORMER
R12 N-4023	82 OHM 2.W 10%	5 N-4846	2ND I.F. TRANSFORMER
R13 N-4823	56,000 OHM .5W 10%	6 N-4985	TRIMMER
C1 N-1345	.05 MFD 200V 20%	7 N-6191	OUTPUT TRANSFORMER
C2 N-1345	.05 MFD 200V 20%	8 N-6187	5" SPEAKER
C3 N-6015	100 MMFD 500V 20%		
C4 N-4894	.005 MFD 600V -15+40%		
C5 N-6135	250 MMFD 500V 20%		

ALL VOLTAGES SHOWN ARE MEASURED FROM TERMINAL TO BUSS. LINE VOLTAGE 117 A.C.

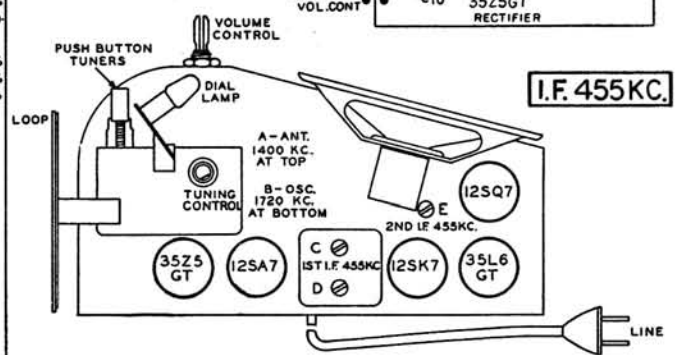

GENERAL DATA. The alignment of this receiver requires the use of a test oscillator that will cover the frequencies of 455, 600, 1400 and 1720 KC and an output meter to be connected across the primary or secondary of the output transformer. If possible, all alignments should be made with the volume control on maximum and the test oscillator output as low as possible to prevent the AVC from operating and giving false readings.

CORRECT ALIGNMENT PROCEDURE. The intermediate frequency (I.F.) stages should be aligned properly as the first step. After the I.F. transformers have been properly adjusted and peaked, the broadcast band should be adjusted.

I.F. ALIGNMENT. Remove the chassis and loop antenna from the cabinet and set them up on the bench so that they occupy exactly the same respective positions on the bench as they did in the cabinet. Care should be taken to have no iron or other metal near the loop. Do not make this set-up on a metal bench. With the gang

condenser set at minimum, adjust the test oscillator to 455 KC and connect the output to the grid of the first detector tube (12SA7) through a .05 or .1 mfd. condenser. The ground on the test oscillator should be connected to the ground buss, indicated on the circuit diagram. Align all three I.F. trimmers to peak or maximum reading on the output meter.

BROADCAST BAND ALIGNMENT. Connect the test oscillator to the antenna of the set through a 100 mmfd. (.0001) condenser. With the gang condenser set at minimum capacity, set the test oscillator at 1720 KC, and adjust the oscillator (or 1720 KC trimmer) on gang condenser. Next—set the test oscillator at 1400 KC, and tune in the signal on the gang condenser. Adjust the antenna trimmer (or 1400 KC trimmer) for maximum signal. Next set the test oscillator at 600 KC, and tune in signal on condenser to check alignment of coils.

SONORA RADIO
Models WA-243, -244
WAU-243, -244

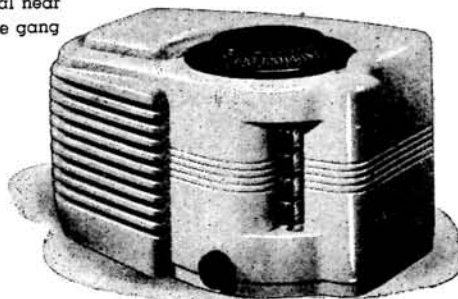

MANUAL OF 1948 MOST-OFTEN-NEEDED RADIO DIAGRAMS

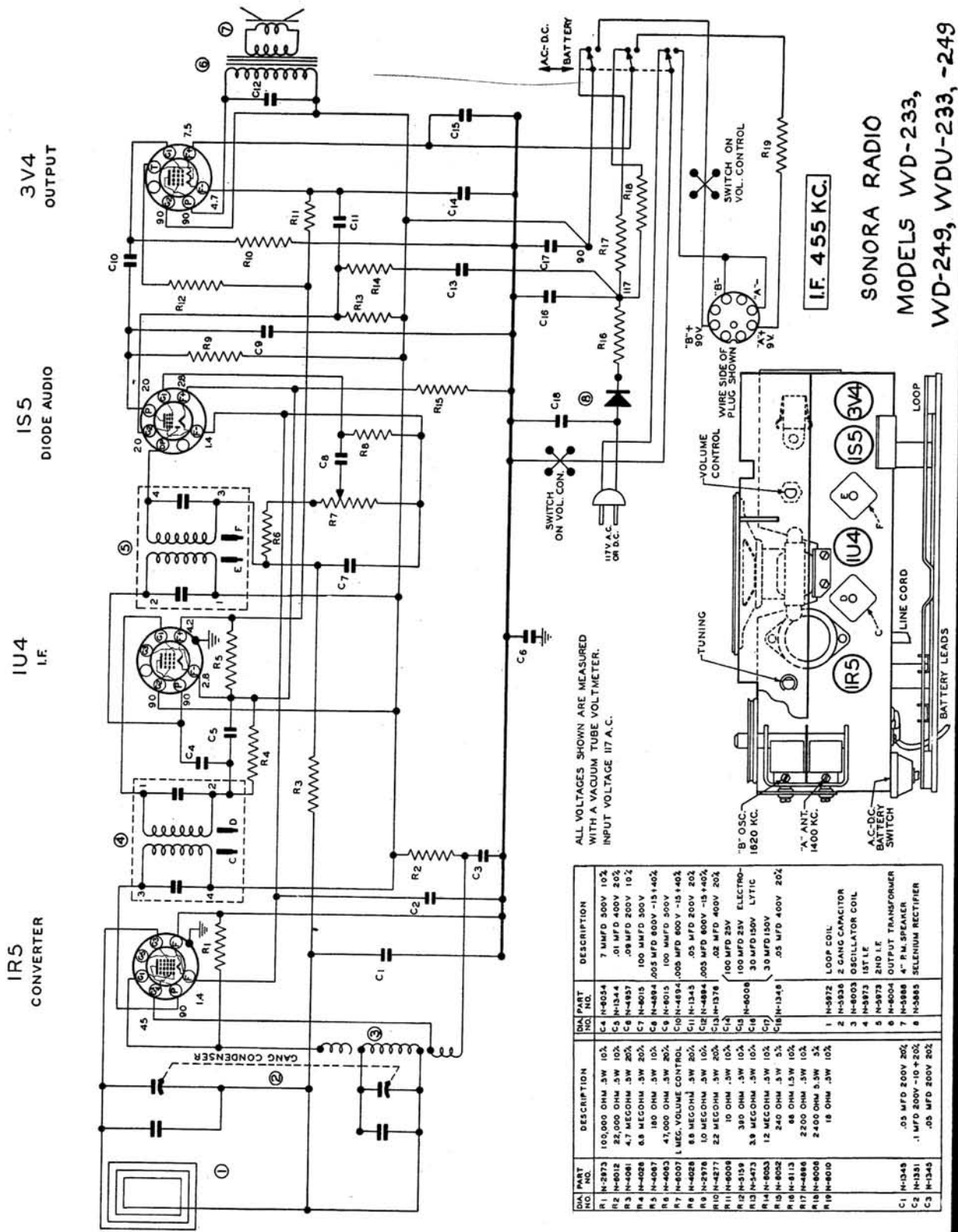

MANUAL OF 1948 MOST-OFTEN-NEEDED RADIO DIAGRAMS

Sparton Superheterodyne Model 5-16

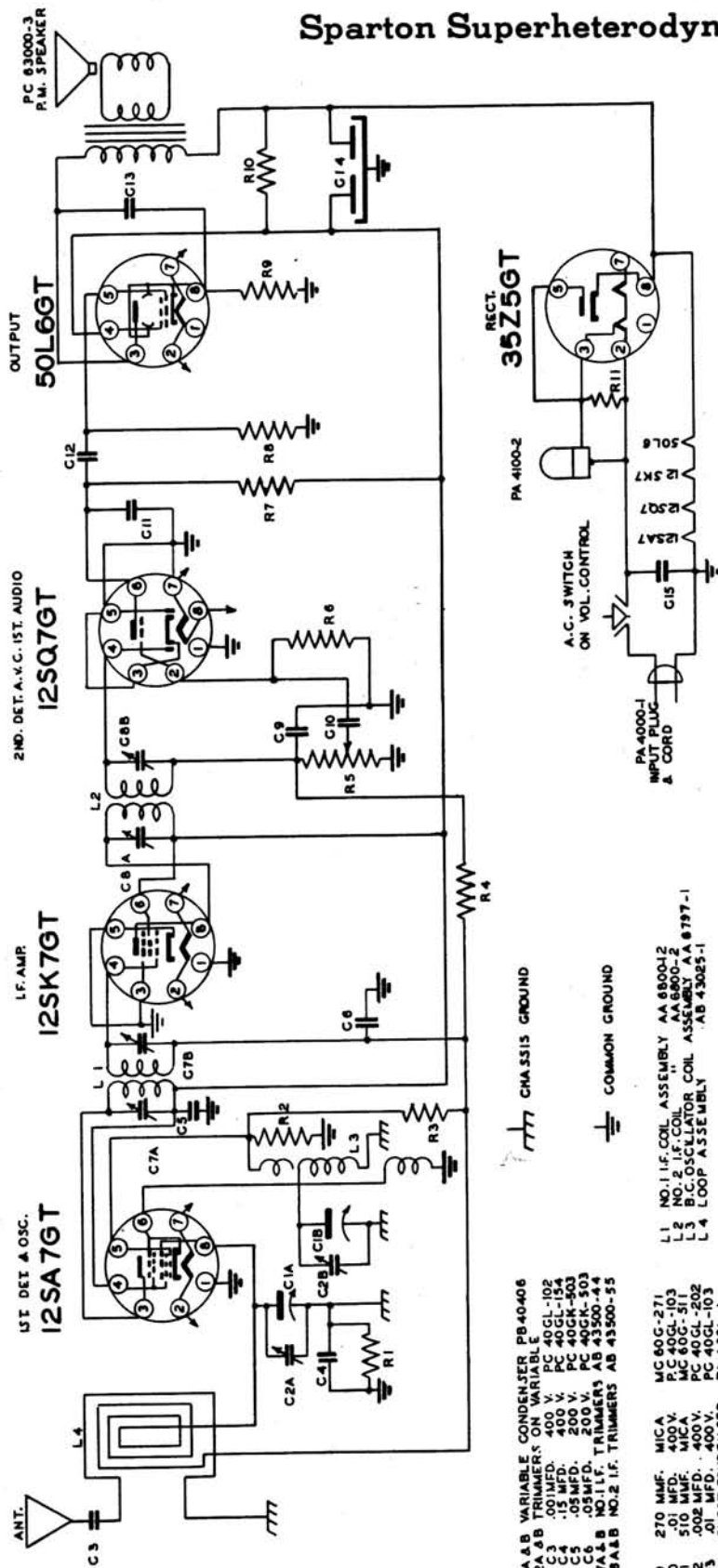

1ST DET. & OSC.
12SA7GT

L.F. AMP.
12SK7GT

2ND DET. A.C. 1ST. AUDIO
12SQ7GT

OUTPUT
50L6GT

- C1A & B VARIABLE CONDENSER PB 40406
- C2A & B TRIMMERS ON V. C. PC 40GL-102
- C3 .01 MFD. 400 V. PC 40GL-154
- C4 .15 MFD. 400 V. PC 40GL-154
- C5 .200 V. 200 V. PC 40GK-503
- C6 .05 MFD. 200 V. PC 40GK-503
- C7A & B NO. 1 I.F. TRIMMERS AB 43500-44
- C8A & B NO. 2 I.F. TRIMMERS AB 43500-55

- C9 270 MFD. MICA MC 60G-271
- C10 .01 MFD. 400 V. MC 40GL-103
- C11 .01 MFD. 400 V. MC 40GL-103
- C12 .008 MFD. 400 V. PC 40GL-202
- C13 .01 MFD. 400 V. PC 40GL-103
- C14 ELECT. CONDENSER PA 4301-1
- C15 RED 30MFD. YELLOW 40 MFD.

- R1 150,000Ω .5W BR12 N-154
- R2 22,000Ω .5W BR12 S-223
- R3 75 MEGOHM .5W BR12 S-156
- R4 2.2 MEGOHM .5W BR12 S-156
- R5 .5 MEG. VOL. CONT. A.S.W. PA 4400-3
- R6 5.0 MEGOHM .5W BR12 S-355
- R7 470,000Ω .5W BR12 N-474
- R8 150,000Ω .5W BR12 S-151
- R9 1200Ω 1W. CR12 S-122
- R10 82 Ω .5W BR12 S-820

RECT.
35Z5GT

CHASSIS GROUND
COMMON GROUND

- L1 NO. 1 I.F. COIL ASSEMBLY AA 68004-2
- L2 NO. 2 I.F. COIL " AA 6800-2
- L3 B.C. OSCILLATOR COIL ASSEMBLY AA 6797-1
- L4 LOOP ASSEMBLY AB 43025-1

OPERATION	ALIGNMENT OF	GENERATOR CONNECTED TO	DUMMY ANTENNA	GENERATOR FREQUENCY	TUNING COND. SETTING	TRIMMER	REMARKS
1	Set dial pointer with left hand stop line and with condenser closed.						
2	I.F.	*	**	456 KC	Open	C8A & B	Peak accurately
3	B.C.	**	Dummy Loop	1500 KC	1500 KC	C7A & B	Peak accurately
4	(Repeat operation 2 and 3).						
5	(Check calibration at 600 KC, 1000 KC, and 1500 KC).						
6	(Check operations 1 to 5 inclusive).						

* Pin No. 6 on 12SA7GT
 ** Standard Dummy Driver Loop
 *** Driver Loop.

MANUAL OF 1948 MOST-OFTEN-NEEDED RADIO DIAGRAMS

SPARTON SUPERHETERODYNE MODEL 5-07 PA INTERMEDIATE FREQUENCY 456 KC.

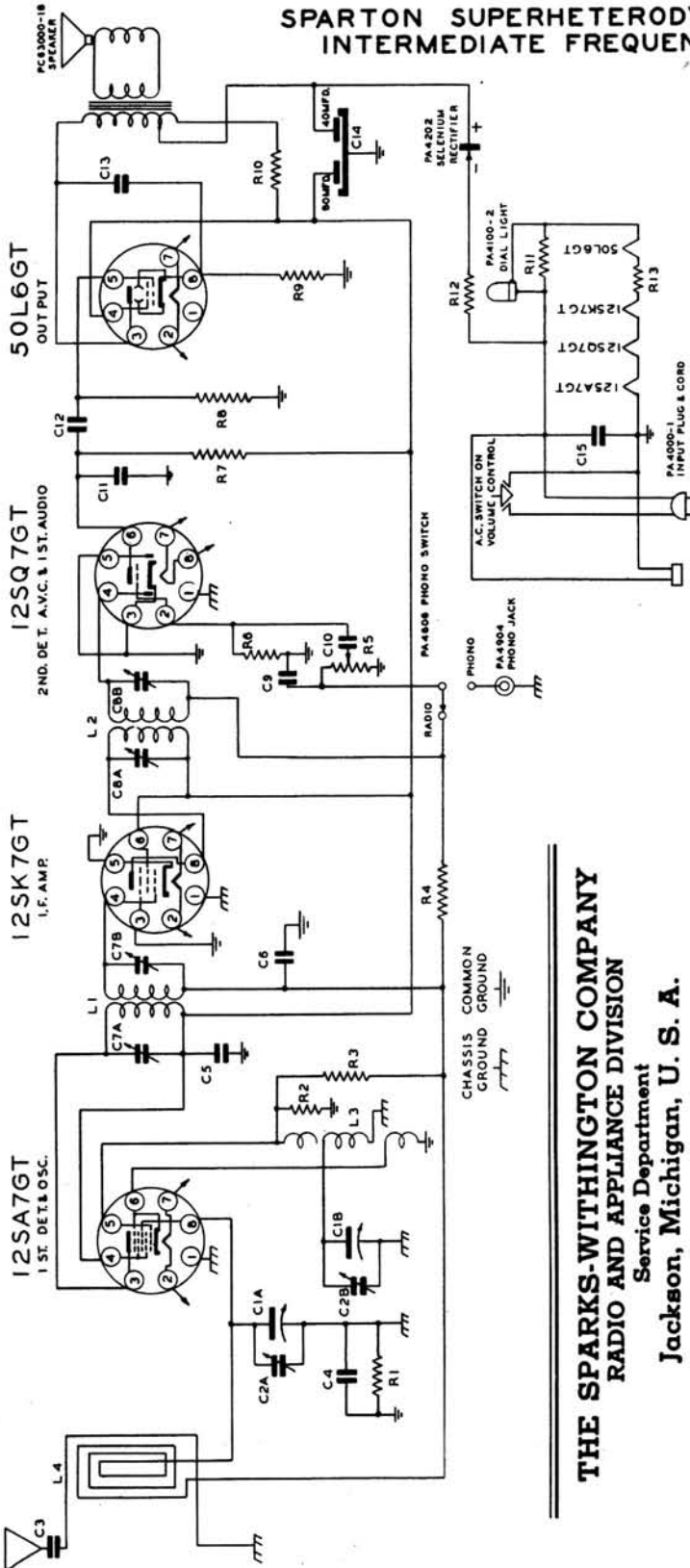

THE SPARKS-WITHINGTON COMPANY
RADIO AND APPLIANCE DIVISION
Service Department
Jackson, Michigan, U. S. A.

RECEIVER OPERATED ON: A.C.
Line Voltage: 117 Volts

TUBE	Position of Volume Control: Full with set tuned to quiet channel.							
	No. 1	No. 2	No. 3	No. 4	No. 5	No. 6	No. 7	No. 8
12SA7GT	0	0	97.0	97.5	**	0	12.4*	0
12SK7GT	0	24.6*	0	-5	0	97.5	37.2*	97.0
12SQ7GT	0	0.5	0	**	0	5.5	24.6*	12.4*
50L6GT	0	11.2*	131	97	0	117*	66.0*	6.2

NOTE: Voltage readings are for schematic diagram.
Always use meter scale which will give greatest deflection within scale limits. All DC measurements made with 20,000 ohms per volt voltmeter. All AC voltages made with rectifier type voltmeter.
* Designates A.C. Volts
** Cannot be measured with 20,000 ohms per volt voltmeter.

- C1A-B VARIABLE CONDENSER PB-40406
C2A-B TRIMMERS ON VARIABLE
C3 .001 MFD. 400 V.
C4 .05 MFD. 200 V.
C5 .05 MFD. 200 V.
C6 .05 MFD. 200 V.
C7A-B NO.1 I.F. TRIMMERS
C8A-B NO.2 I.F. TRIMMERS
C9 .270 MME. MICA
C10 .01 MFD. 400 V.
C11 .50 MME. MICA
C12 .01 MFD. 400 V.
C13 .02 MFD. 400 V.
C14 ELECTROLYTIC
C15 .05 MFD. 400 V.
R1 150,000 OHM .5 W.
R2 22,000 OHM .5 W.
R3 22,000 OHM .5 W.
R4 5 MEGOHM .5 W.
R5 5 MEG. VOL. CONT. & SW. PA4400-6
R6 5.6 MEGOHM .5 W.
R7 220,000 OHM .5 W.
R8 470,000 OHM .5 W.
R9 1,200 OHM .1 W.
R10 1,200 OHM .1 W.
R11 50.6 CT
R12 27 OHM .5 W.
R13 165 OHM .5 W.
PA100-2 DIAL LIGHT
PA4000-1 INPUT PLUG & CORD
PA4300-1 RECTIFIER
PA4300-2 RECTIFIER
PA4800-1 N.O.I.F. COIL ASSEM.
PA4800-2 A.C. OSC. COIL ASSEM.
PA4800-3 A.C. OSC. COIL ASSEM.
PA4800-4 A.C. OSC. COIL ASSEM.
PA4800-5 A.C. OSC. COIL ASSEM.
PA4800-6 A.C. OSC. COIL ASSEM.
PA4800-7 A.C. OSC. COIL ASSEM.
PA4800-8 A.C. OSC. COIL ASSEM.
PA4800-9 A.C. OSC. COIL ASSEM.
PA4800-10 A.C. OSC. COIL ASSEM.
PA4800-11 A.C. OSC. COIL ASSEM.
PA4800-12 A.C. OSC. COIL ASSEM.
PA4800-13 A.C. OSC. COIL ASSEM.
PA4800-14 A.C. OSC. COIL ASSEM.
PA4800-15 A.C. OSC. COIL ASSEM.
PA4800-16 A.C. OSC. COIL ASSEM.
PA4800-17 A.C. OSC. COIL ASSEM.
PA4800-18 A.C. OSC. COIL ASSEM.
PA4800-19 A.C. OSC. COIL ASSEM.
PA4800-20 A.C. OSC. COIL ASSEM.
PA4800-21 A.C. OSC. COIL ASSEM.
PA4800-22 A.C. OSC. COIL ASSEM.
PA4800-23 A.C. OSC. COIL ASSEM.
PA4800-24 A.C. OSC. COIL ASSEM.
PA4800-25 A.C. OSC. COIL ASSEM.
PA4800-26 A.C. OSC. COIL ASSEM.
PA4800-27 A.C. OSC. COIL ASSEM.
PA4800-28 A.C. OSC. COIL ASSEM.
PA4800-29 A.C. OSC. COIL ASSEM.
PA4800-30 A.C. OSC. COIL ASSEM.

MANUAL OF 1948 MOST-OFTEN-NEEDED RADIO DIAGRAMS

Model 6-26 & 6-26-PA

Spartan

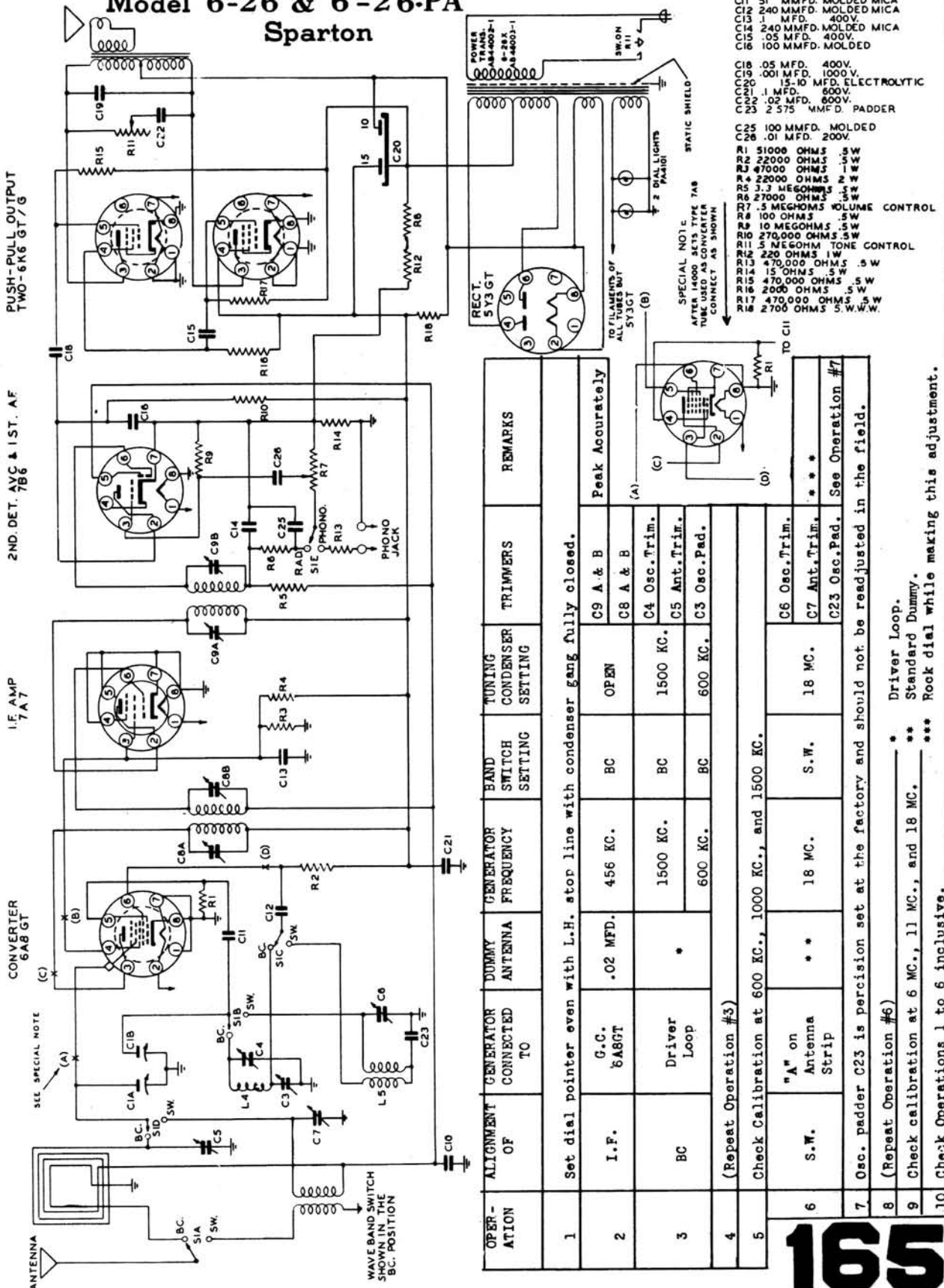

OPERATION	ALIGNMENT OF	GENERATOR CONNECTED TO	DUMMY ANTENNA	GENERATOR FREQUENCY	BAND SWITCH SETTING	TUNING CONDENSER SETTING	TRIMMERS	REMARKS
1	Set dial pointer even with L.H. stop line with condenser gang fully closed.							
2	I.F.	G.C. 6A8GT	.02 MFD.	456 KC.	BC	OPEN	C9 A & B C8 A & B	Peak Accurately (A)
3	BC	Driver Loop	*	1500 KC.	BC	1500 KC.	C4 Osc.Trim. C5 Ant.Trim. C3 Osc.Pad.	(C) (D)
4	(Repeat Operation #3)							
5	Check Calibration at 600 KC., 1000 KC., and 1500 KC.							
6	S.W.	"A" on Antenna Strip	**	18 MC.	S.W.	18 MC.	C6 Osc.Trim. C7 Ant.Trim. C23 Osc.Pad.	See Operation #7
7	Osc. padder C23 is precision set at the factory and should not be readjusted in the field.							
8	(Repeat Operation #6) * Driver Loop.							
9	Check calibration at 6 MC., 11 MC., and 18 MC. ** Standard Dummy.							
10	Check Operations 1 to 6 inclusive. *** Rock dial while making this adjustment.							

MANUAL OF 1948 MOST-OFTEN-NEEDED RADIO DIAGRAMS

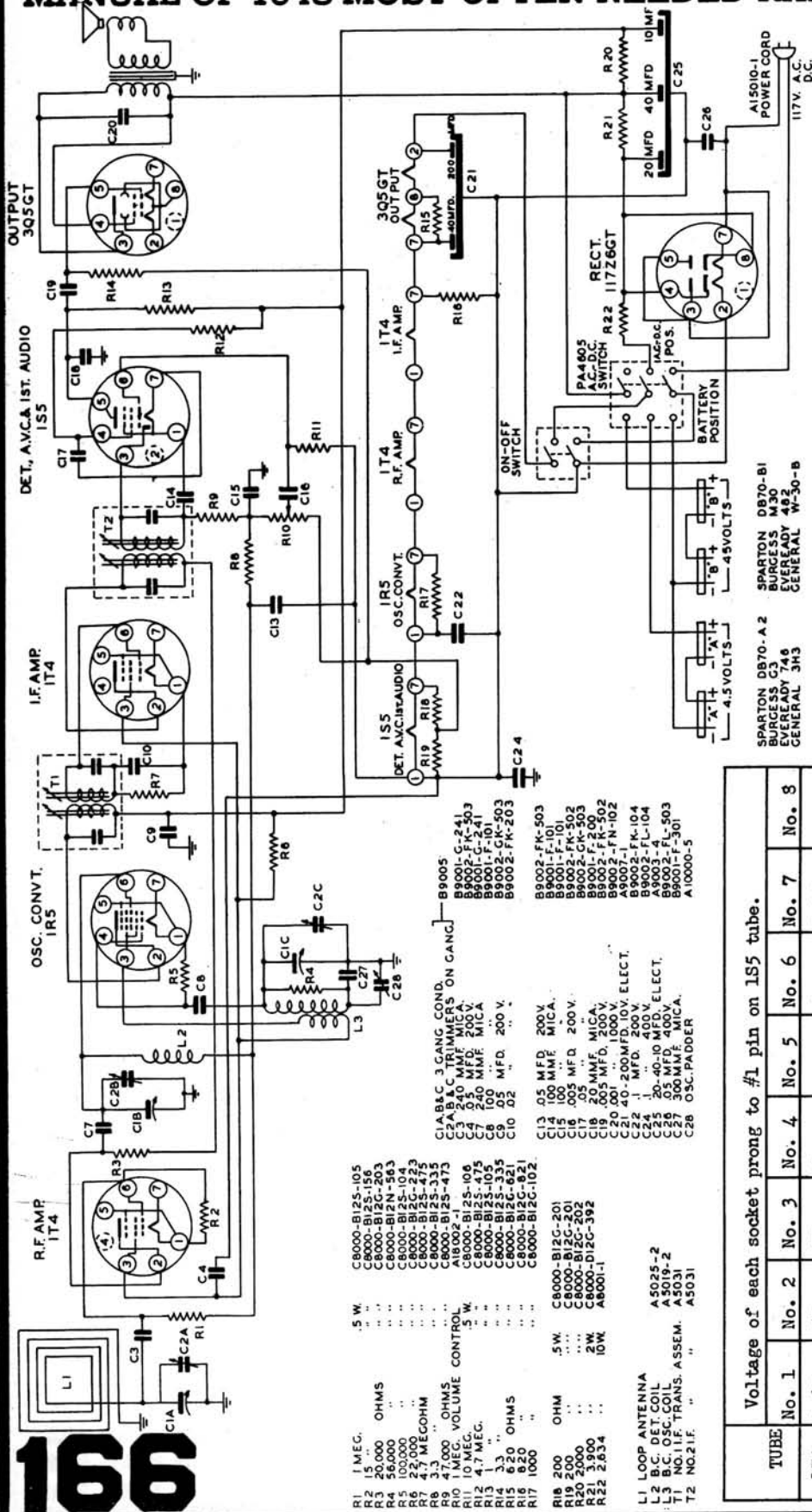

**SPARTON SUPERHETERODYNE MODEL 6-06
INTERMEDIATE FREQUENCY 456 KC.**

SPARTON DB70-A 2
BURNESS C3
EVEREADY 745
GENERAL 3H3

SPARTON DB70-B1
BURNESS M30
EVEREADY 482
GENERAL W-30-B

TUBE	Voltage of each socket prong to #1 pin on 1S5 tube.							
	No. 1	No. 2	No. 3	No. 4	No. 5	No. 6	No. 7	No. 8
1T4	2.5f	80	39	0	-	0	3.9f	-
1R5	1.24f	80	39	.38	1.24	0	2.3f	-
1T4	4f	80	39	-	4	0	5.2f	-
1S5	B-*	80	0	13	14.25	0	1.25f	-
3Q5GT	-	8f	85	90	0	.5	5.3f	6.5f
11726	-	0	117*	135	117*	-	117*	135

Always use meter scale which will give greatest deflection within scale limits. All DC measurements made with 20,000 ohms per volt voltmeter. All AC voltages made with rectifier type voltmeter.

f Filament Voltage

* A.C. Voltage

** All voltages measured from this point to socket prongs.

- R1 1 MEG.
 - R2 5 000 OHMS
 - R3 25-150
 - R4 56,000
 - R5 100,000
 - R6 25,000
 - R7 1.7 MEGOHM
 - R8 3.7 MEGOHM
 - R9 47,000 OHMS
 - R10 10 MEG.
 - R11 4.7 MEG.
 - R12 3.3
 - R13 6.20 OHMS
 - R16 820
 - R17 1000
 - R18 200 OHM
 - R19 200
 - R20 2,000
 - R21 3,900
 - R22 2.854
- 5W
 - 5W
 - 5W
 - 2W
 - 10W
- C1A B.C. OSC. COIL
 - L1 LOOP ANTENNA
 - L2 B.C. DET. COIL
 - L3 B.C. OSC. COIL
 - T1 NO. 11F. TRANS. ASSEM.
 - T2 NO. 21F. " " A5031
- C1A B.C. 3 GANG COND.
 - C2A 340 MFD. MICA
 - C3 340 MFD. MICA
 - C4 .05 MFD. MICA
 - C7 240 MFD. MICA
 - C8 .05 MFD. MICA
 - C9 .05 MFD. MICA
 - C10 .02
 - C13 .05 MFD. 200V
 - C14 100 MFD. 200V
 - C15 .005 MFD. 200V
 - C17 .05
 - C18 20 MFD. MICA
 - C19 200 MFD. 150V
 - C20 40-200 MFD. 10V. ELECT.
 - C21 40-200 MFD. 10V. ELECT.
 - C22 .1 MFD. 200V
 - C24 10-40.18 400V
 - C25 300 MFD. MICA
 - C26 300 MFD. MICA
 - C27 300 MFD. MICA
 - C28 OSC. PADDER
- B9005
 - B9001-G-241
 - B9002-FK-503
 - B9001-F-101
 - B9002-GK-503
 - B9002-FK-203
 - B9002-FK-503
 - B9001-F-101
 - B9002-FK-102
 - A9007-1
 - B9002-FK-104
 - B9002-FL-104
 - B9002-FL-503
 - B9001-F-301
 - A10000-5

MANUAL OF 1948 MOST-OFTEN-NEEDED RADIO DIAGRAMS

SERVICE DATA FOR STEWART-WARNER MODEL [A41T1] 9032-A

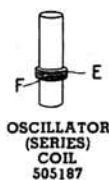
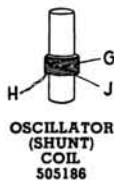

Lettered terminals in illustrations correspond to similarly lettered terminals on the circuit diagram.

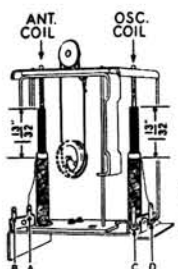
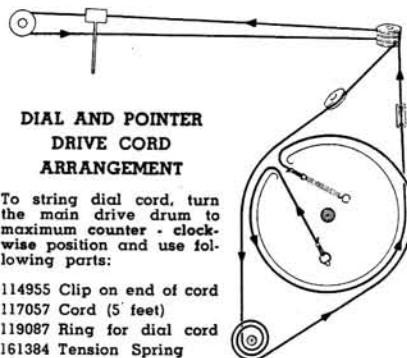

SLUG TUNER ASSEMBLY

(Drive Parts)

- 117057 Cord (12")
- 114955 Clip on cord
- 504012 Spring

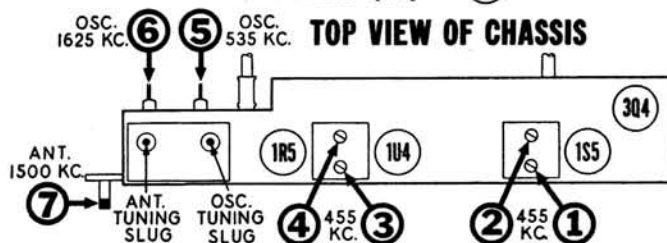

TRIMMER LOCATIONS

SOCKET VOLTAGES

Measured with voltmeter having sensitivity of 1000 ohms per volt except where indicated by (*). The (*) symbol designates a vacuum tube voltmeter measurement.

VOLUME ON FULL WITH NO SIGNAL

DIAL TUNED TO 540 KC.

BOTTOM VIEW OF CHASSIS

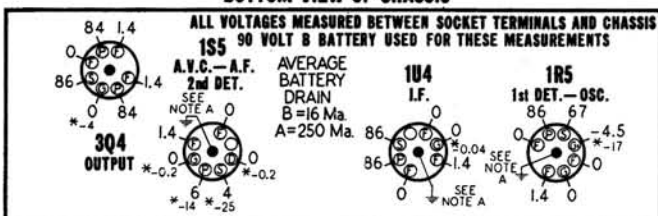

REAR OF CHASSIS

NOTE A: Grounding of center stud on tube socket is necessary to reduce capacity coupling between other pins. Oscillation may result if this ground is omitted.

CONDENSERS

12	502790	Condenser—mica 200 Mmfd. 500 volt.....
14	505179	Condenser—trimmer 30 to 270 Mmfd.....
16	505183	Condenser—ceramic 47 Mmfd. ± 2% 500 volt.....
19	502929	Condenser—mica 47 Mmfd. 500 volt.....
21, 22	502153	Condenser—.05 Mfd. 200 volt.....
27	502155	Condenser—.1 Mfd. 200 volt.....
31	502931	Condenser—mica 100 Mmfd. 500 volt.....
32	502156	Condenser—.004 Mfd. 400 volt.....
34	502153	Condenser—.05 Mfd. 200 volt.....
36	502271	Condenser—mica 260 Mmfd. 500 volt.....
38	504726	Condenser—.01 Mfd. 200 volt.....
41	505174	Condenser—electrolytic 10 Mfd. 150 volt.....
42	502263	Condenser—.5 Mfd. 150 volt.....
43	502453	Condenser—.002 Mfd. 400 volt.....

RESISTORS

13	502268	Resistor—carbon 1 Meg. 1/4 watt.....
18	502132	Resistor—carbon 100,000 Ohms 1/4 watt.....
23	502133	Resistor—carbon 220,000 Ohms 1/4 watt.....
24	502459	Resistor—carbon 6,800 Ohms 1/4 watt.....
28	502268	Resistor—carbon 1 Meg. 1/4 watt.....
30-A, B	505197	Volume control 1 Meg. (with switch).....
33	502136	Resistor—carbon 10 Meg. 1/4 watt.....
35	502268	Resistor—carbon 3.3 Meg. 1/4 watt.....
37	502268	Resistor—carbon 1 Meg. 1/4 watt.....
39	502268	Resistor—carbon 1 Meg. 1/4 watt.....
40	505184	Resistor—carbon 270 Ohms 1/4 watt.....

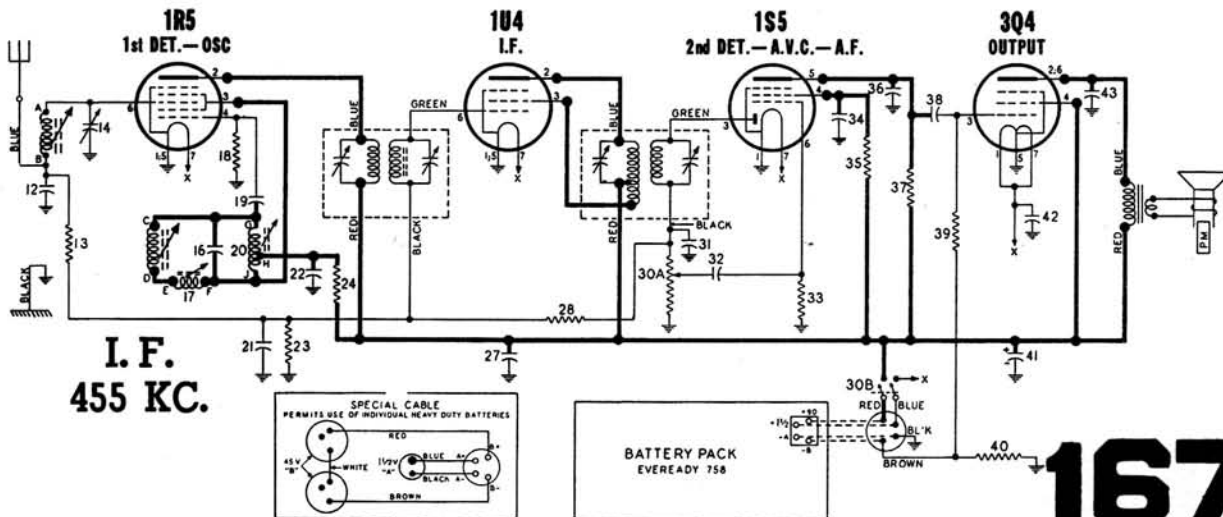

MANUAL OF 1948 MOST-OFTEN-NEEDED RADIO DIAGRAMS

STEWART-WARNER MODELS [A51T1 9020-A] [A51T2 9020-B] [A51T3 9020-C]

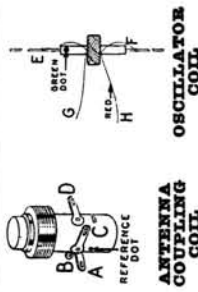

Lettered terminals in illustrations correspond to similarly lettered terminals on the circuit diagram.

50B5 OUTPUT

12AT6 2nd DET.—A.V.C.—A.F.

12BA6 I.F.

12BE6 1st DET.—OSC.

35W4 RECTIFIER

[A51T4 9020-D]

SOCKET VOLTAGES

Measured with voltmeter having sensitivity of 1000 ohms per volt except where indicated by (*). The (*) designates a vacuum tube voltmeter measurement.

VOLUME ON FULL WITH NO SIGNAL DIAL TUNED TO 540 KC.



NOTE A: Grounding of center stud on tube socket is necessary to reduce capacity coupling between other pins. Oscillation may result if this ground is omitted.

I.F. 455 KC.

168

To string dial cord, turn the drive drum to maximum clockwise position and use the following parts:

- 114955 Clip on end of cord
- 117057 Cord (2 feet required)
- 119087 Ring for dial cord
- 505161 Tension Spring

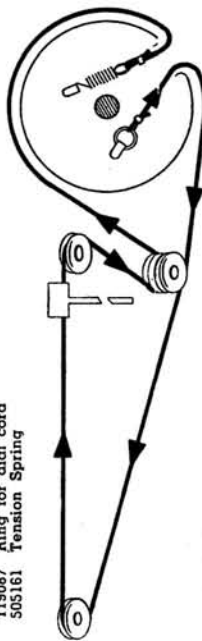

AN ALTERNATE TYPE OF I.F. TRANSFORMER WAS USED BOTH ACCESSIBLE THROUGH THE TOP OF THE CAB.

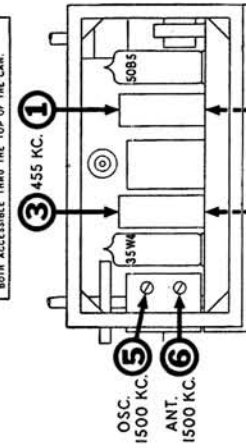

CONDENSERS	
12	502158 Condenser—.004 Mid. 400 volt.
14	504380 Condenser—variable gang (with drum).
16	504434 Condenser—ceramic 50 Mmfd. 500 volt.
18	504446 Condenser—1 Mid. 400 volt.
23	504444 Condenser—.05 Mid. 400 volt.
26	502271 Condenser—mica 260 Mmfd. 500 volt.
28	504445 Condenser—.004 Mid. 150 volt.
30	502271 Condenser—mica 260 Mmfd. 500 volt.
32	504450 Condenser—.01 Mid. 400 volt.
35	504448 Condenser—electrolytic 20 Mfd. 150 volt.
36	504431 Condenser—electrolytic 20 Mfd. 150 volt.
37	504431 Condenser—.05 Mid. 400 volt.
42	502285 Condenser—.10 Mmfd. 500 volt.
43	502285 Condenser—.10 Mmfd. 500 volt.
RESISTORS	
15	504440 Resistor—carbon 22,000 ohms 1/3 watt.
19	504435 Resistor—carbon 220,000 ohms 1/3 watt.
21	504436 Resistor—carbon 82 ohms 1/2 watt.
22	504441 Resistor—carbon 2.2 Meg. 1/3 watt.
27A, B	504381 Volume control—with switch; 1 Meg.
29	504439 Resistor—carbon 3.3 Meg. 1/3 watt.
31	504438 Resistor—carbon 470,000 ohms 1/3 watt.
33	504438 Resistor—carbon 10,000 ohms 1/3 watt.
34	504437 Resistor—carbon 150 ohms 1/2 watt.
38	502574 Resistor—carbon 33 ohms 1/2 watt.
41	504442 Resistor—carbon 1300 ohms 1 watt.

MANUAL OF 1948 MOST-OFTEN-NEEDED RADIO DIAGRAMS

STEWART-WARNER MODELS [A61CR1] ; [A61CR2] ; [A61CR3] & [A61CR4]

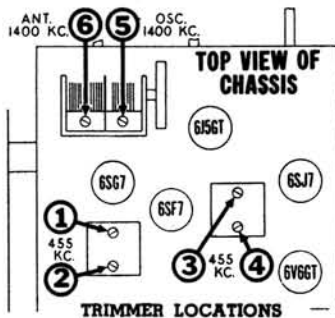

TRIMMER LOCATIONS

DIAL AND POINTER DRIVE CORD ARRANGEMENT SIDE VIEW (With dial plate removed)

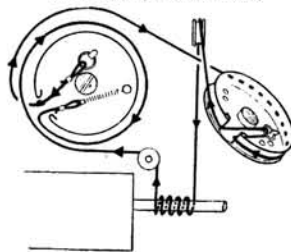

To string dial cord first slip pointer off its shaft. Then remove dial scale by taking out the six clips around its edges. Dial plate may now be taken off by removing the two screws which are visible and accessible at front of chassis. Now set gang condenser to fully open position and use the following parts:

- 114955 Clip on end of cord
- 117057 Cord (3 feet)
- 119087 Ring for dial cord
- 505161 Tension spring

SOCKET VOLTAGES

Measured with voltmeter having sensitivity of 1000 ohms per volt except where indicated by (*). The (*) symbol designates a vacuum tube voltmeter measurement.

DIAL TUNED TO 540 KC.
VOLUME ON FULL WITH NO SIGNAL
RADIO-PHONO & TONE SWITCH IN "RADIO-BASS" POSITION

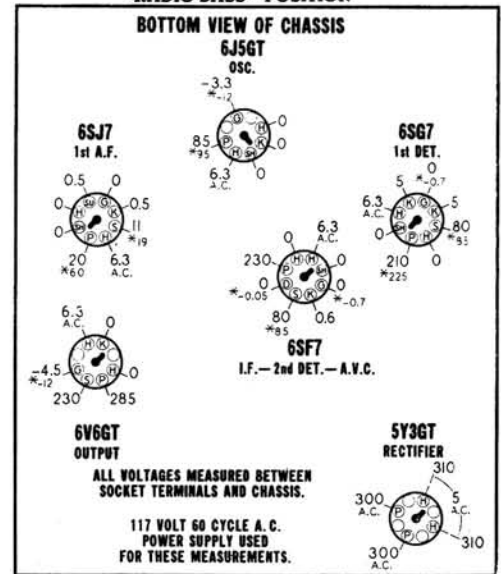

ALTERNATE TYPES OF RADIO-PHONO & TONE SWITCH 505317

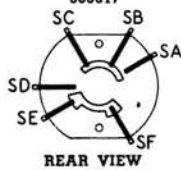

REAR VIEW

LOCATING LUG

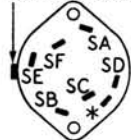

REAR VIEW

*Not used; may serve as wiring junction point.

Lettered terminals in illustrations correspond to similarly lettered terminals on the circuit diagram



OSCILLATOR COIL 505326

DIA-GRAM NO.	PART NO.	DESCRIPTION
--------------	----------	-------------

CONDENSERS

13	502151	Condenser—.01 Mfd. 400 volt
14-A, B	505315	Condenser—variable gang (with drum)
16	502931	Condenser—mica 100 Mmfd. 500 volt
19	502153	Condenser—.05 Mfd. 200 volt
20	502157	Condenser—.05 Mfd. 400 volt
22	502152	Condenser—.02 Mfd. 400 volt
25	502153	Condenser—.05 Mfd. 200 volt
33	502931	Condenser—mica 100 Mmfd. 500 volt
36	502156	Condenser—.004 Mfd. 400 volt
39	502152	Condenser—.02 Mfd. 400 volt
41	502157	Condenser—.05 Mfd. 400 volt
45	502405	Condenser—.25 Mfd. 400 volt
48	502150	Condenser—.004 Mfd. 600 volt
49	502271	Condenser—mica 260 Mmfd. 500 volt
51	502410	Condenser—.1 Mfd. 400 volt
53	502152	Condenser—.02 Mfd. 400 volt
55-A, B, C	502207	Condenser—electrolytic A—20 Mfd. 400 volt B—10 Mfd. 400 volt C—20 Mfd. 25 volt

RESISTORS

57	502156	Condenser—.004 Mfd. 400 volt
12	502466	Resistor—carbon 33,000 Ohms 1 watt
15	502131	Resistor—carbon 47,000 Ohms 1/4 watt
18	502128	Resistor—carbon 2,200 Ohms 1/4 watt
21	502288	Resistor—carbon 47,000 Ohms 1 watt
23	502459	Resistor—carbon 6,800 Ohms 1/4 watt
26	502269	Resistor—carbon 3.3 Meg. 1/4 watt
27	502264	Resistor—carbon 47 Ohms 1/4 watt
32	502131	Resistor—carbon 47,000 Ohms 1/4 watt
35-A, B	505318	Volume Control 1 Meg. (with switch)
37	502132	Resistor—carbon 100,000 Ohms 1/4 watt
38	502408	Resistor—carbon 68,000 Ohms 1/4 watt
40	502468	Resistor—carbon 4.7 Meg. 1/4 watt
42	502406	Resistor—carbon 1,500 Ohms 1/4 watt
44	502135	Resistor—carbon 2.2 Meg. 1/4 watt
50	502133	Resistor—carbon 220,000 Ohms 1/4 watt
52	502133	Resistor—carbon 220,000 Ohms 1/4 watt
54	502134	Resistor—carbon 470,000 Ohms 1/4 watt
56	504771	Resistor—carbon 3,300 Ohms 2 watt
58	502293	Resistor—wire wound 200 ohms 2 watt

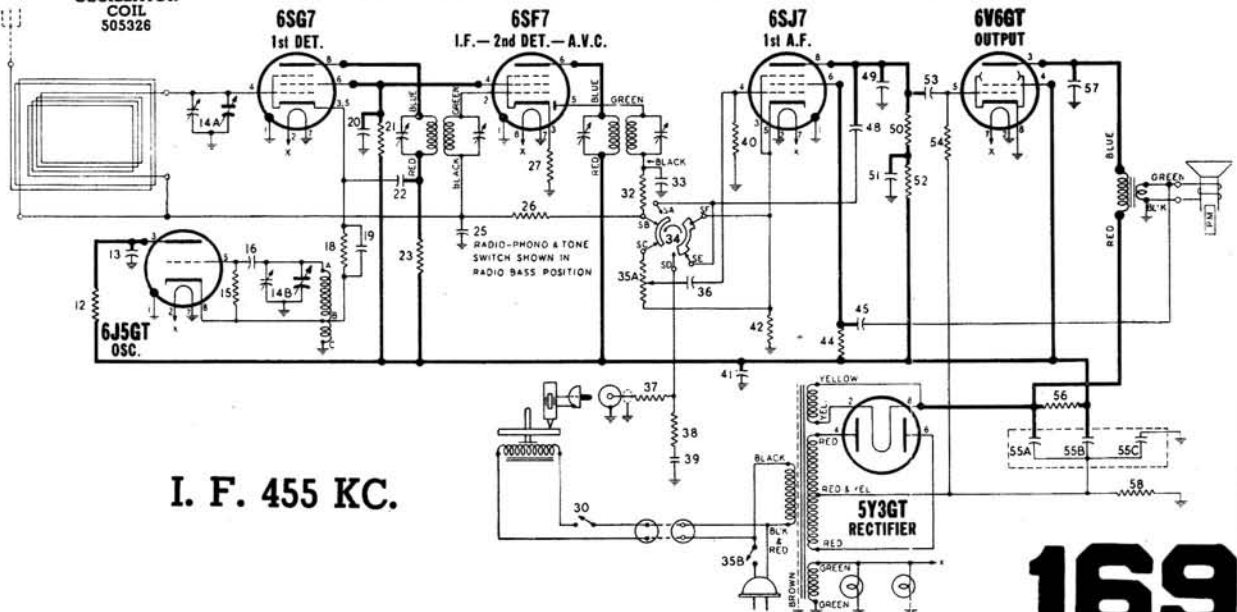

I. F. 455 KC.

MANUAL OF 1948 MOST-OFTEN-NEEDED RADIO DIAGRAMS

TEMPLETONE RADIO MFG. CORP.

Models E-510 to E-519, also G-513 and G-515 are almost identical and correspond with few exceptions to the diagram below. In some sets, 14 volt tubes were used as indicated.

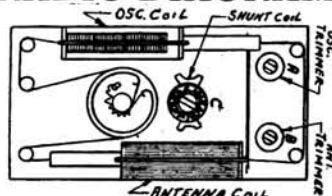

Controls: Only two controls are required for operation. The left-hand control puts set into operation, increases the volume with clockwise rotation, and includes the power switch. The right-hand control tunes the dial to the desired station.

Antenna: For normal reception, no outside aerial is required, as more than adequate pickup is obtained by the self-contained loop antenna.

At installations remote from the stations desired to be heard, improved results may be obtained by rotating the receiver for maximum response, as the loop antenna has a marked directional effect on weak signals. Reception can also be improved, and the directional effect reduced, by attaching a length of insulated wire approximately 15 to 25 feet long, to the antenna connection provided at the back of the cabinet.

Alignment: No attempt should be made to realign this receiver until it has been determined that a poor tube, or some local condition is not responsible for faulty reception. An output meter may be clipped directly across the voice coil lugs.

The Signal Generator may be connected through a 0.01 mf capacitor (used as dummy antenna) to the lug on RF section (B) of tuning capacitor. Connect ground clip of generator directly to chassis. Align the I. F. trimmers to 455 kc, using least possible input from Signal Generator to avoid developing A.V.C. voltage which would make the tuning adjustments very broad.

To align RF trimmers, remove the 0.01 mf capacitor and connect the Signal Generator leads or two or three turns of heavy wire, forming a self-supporting loop of about 7 or 8 inches diameter, placed about a foot away from the receiver's loop antenna. Again, use the least possible input from the Signal Generator. With the tuning capacitor plates completely out of mesh, and pointer at extreme left end of travel, adjust the oscillator trimmer (A) (on front section of tuning capacitor) to 1700 kc. Readjust both Signal Generator and tuning capacitor to 1550 kc and adjust the RF trimmer (B) (on rear section) for maximum response. With tuning capacitor plates fully meshed, the receiver should tune to 535 kc; however, no adjustment is required at this point. For checking purposes, four fine marks are engraved on the dial plate. These represent, in order, the pointer settings for 1550, 1000, 600 kc, and the pointer position with capacitor plates fully meshed.

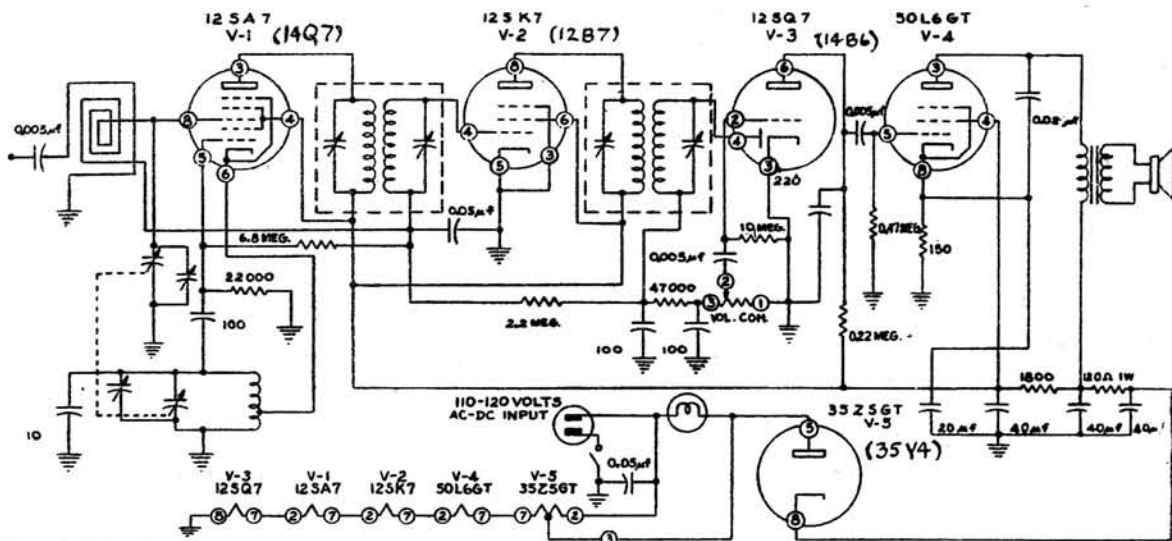

NOTES:

1. RESISTORS ARE IN OHMS, CAPACITORS ARE IN μmf , INDUCTORS ARE IN μH UNLESS OTHERWISE MARKED.
2. VOLUME CONTROL R-4 IS 0.5 MEGOHMS, WITH SWITCH S-1 MOUNTED ON REAR.
3. IN A FEW EARLY MODELS C-12D WAS A SEPARATE 25 μmf CAPACITOR, C-12A WAS 80 μmf , C-12C WAS 20 μmf AND R-11 WAS NOT USED.

MANUAL OF 1948 MOST-OFTEN-NEEDED RADIO DIAGRAMS

TRAV-LER RADIO CORP.

Model 5051

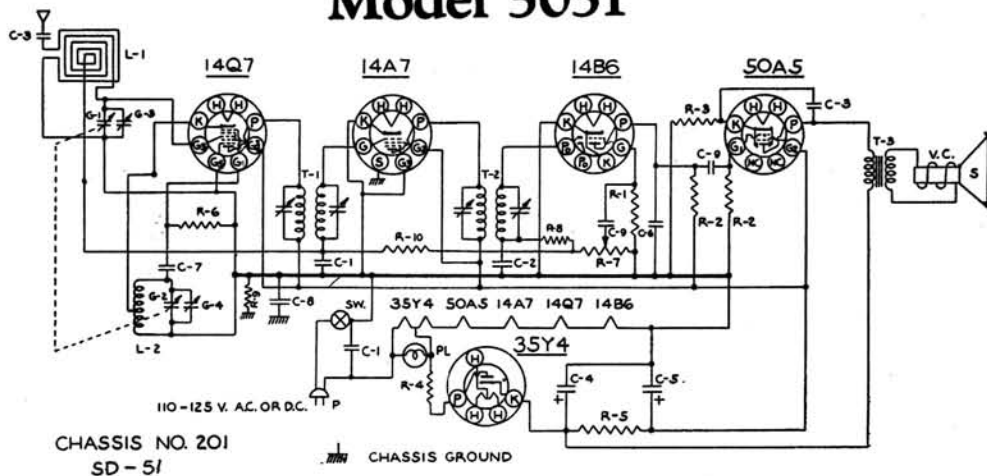

I. F. 455 KC.

PART NO.	DESCRIPTION	PART NO.	DESCRIPTION	PART NO.	DESCRIPTION
IR-13	R-1 22MEG RESISTOR 1/2W 20%	PC-5	G-4 OSC. TRIMMER COND.	LO-11	L-2 OSC. COIL
IR-11	R-2 470M Ω RESISTOR 1/2W 20%	MC-2	C-1 .05 MFD. COND. 400V.	L1-1	T-1 INPUT I.F. TRANSFORMER
IR-14	R-3 150 Ω RESISTOR 1/2W 20%	PC-7	C-2 .0001 MFD. MICA COND. 20%	L1-2	T-2 OUTPUT I.F. TRANSFORMER
IR-4	R-4 47 Ω RESISTOR 1/2W 20%	PC-7	C-3 .01 MFD. COND. 20%	T-3	OUTPUT SPK. TRANSFORMER
IR-15	R-5 2200 Ω RESISTOR 1/2W 20%	EC-12	C-4 40 MFD. 150V ELECTROLYTIC CONDENSER	SPK.-4	V.C. VOICE COIL
IR-16	R-6 33M Ω RESISTOR 1/2W 20%	MC-5	C-5 20 MFD.	S	RM. SPEAKER
VC-3	R-7 1 MEG. VOLUME CONTROL	MC-4	C-6 .0005 MFD. COND. 20%	PB-1	#47 PILOT BULB
GC-4	G-1 GANG CONDENSER	MC-4	C-7 .000056 MFD. MICA 20%	PL	A.C. SW. ON VOL. CONTROL
TC-7	G-2 ANT. TRIMMER COND.	PC-9	C-8 1 MFD. COND. 400V.	CO-1	LINE CORD
IR-10	R-8 47M Ω 1/2W 20%	LL-6	L-1 LOOP ANTENNA	TU-6	IR-23
		IR-20	R-9 220M Ω 1/2W 20%	R-10	3.3MEG. 1/2W. 20%
				PC-8	C-9 .005MFD. 500V

TRAV-LER RADIO CORP.

MODEL No. 5019

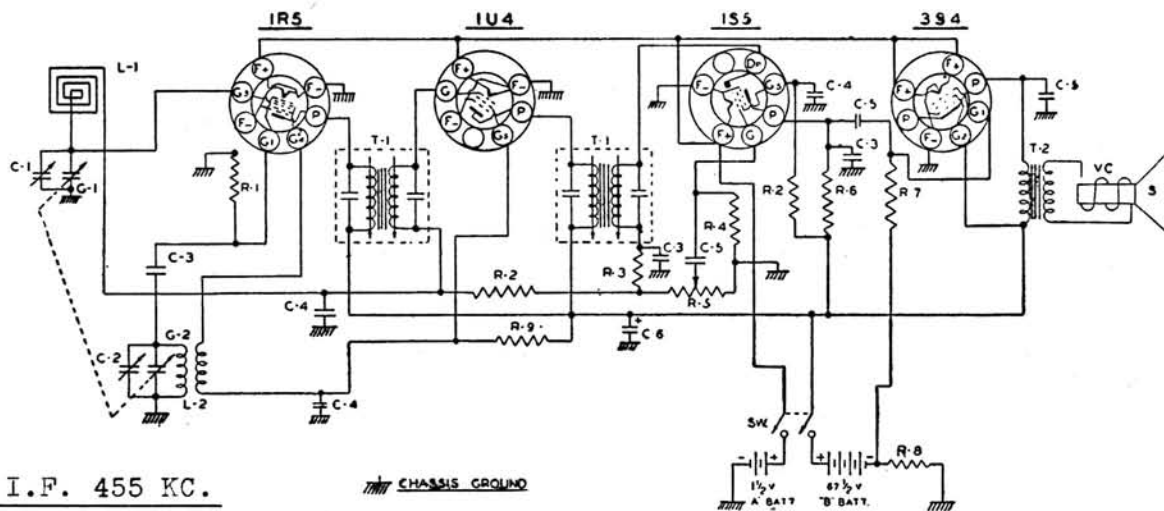

I. F. 455 KC.

PART NO	DESCRIPTION	PART NO	DESCRIPTION
IR-20	R-1 220M Ω RESISTOR 1/2W 20%	GC-4	G-1 GANG CONDENSER
IR-23	R-2 3.3MEG. RESISTOR 1/2W 20%	G-2	LOOP ANTENNA
IR-31	R-3 82M Ω RESISTOR 1/2W 10%	LL-12	L-1 OSC. COIL
IR-3	R-4 10MEG. RESISTOR 1/2W 20%	L1-5	T-1 I.F. TRANSFORMER
VC-8	R-5 1MEG. VOLUME CONTROL	SW	DPST. SWITCH ON VOLUME CONTROL
IR-12	R-6 1MEG. RESISTOR 1/2W 20%	T-2	SPEAKER TRANSFORMER
IR-13	R-7 22MEG. RESISTOR 1/2W 20%	VC	VOICE COIL
IR-5	R-8 220 Ω RESISTOR 1/2W 10%	PM	SPEAKER
IR-37	R-9 10M Ω RESISTOR 1/2W 20%	TU-29	1R5-1U4-1S5-3S4
TC-7	C-1 ANT. TRIMMER		
MC-2	C-2 OSC. TRIMMER ON GANG		
PC-7	C-3 100MFD MICA CONDENSER		
PC-6	C-4 .01 MFD. 400V.		
EC-7	C-5 .005MFD 500V.		
	C-6 20MFD. 80WV.		

MANUAL OF 1948 MOST-OFTEN-NEEDED RADIO DIAGRAMS

Trav-ler Radio Corp. Electric Phonograph Model 7004

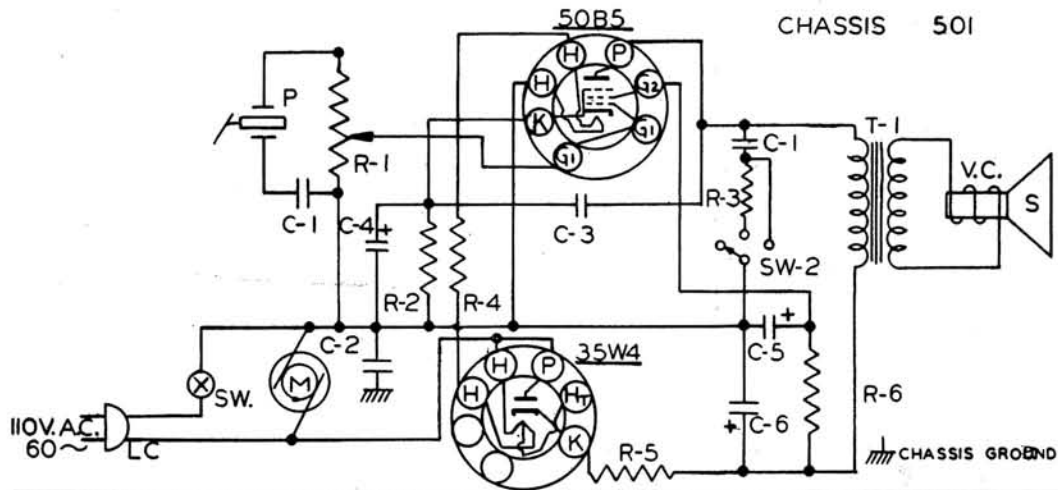

PART NO.	DESCRIPTION	PART NO.	DESCRIPTION
VC-6	R-1 1/2MEG. VOLUME CONTROL.	M-1	MOTOR 110V. 60~
IR-14	R-2 150~ RESISTOR. 1/2W. 20%	CO-2	LC POWER CORD.
IR-7	R-3 2200~ RESISTOR. 1/2W. 5%	SW-2	A.C. SW. ON VOLUME CONTR.
WR-1	R-4 210~ RESISTOR. 5W. 5% WIRE WOUND.	SW2	TONE SWITCH
IR-17	R-5 39~ RESISTOR. 1/2W. 20%	T-1	OUTPUT TRANSFORMER
IR-18	R-6 4700~ RESISTOR. 1/2W. 20%	VC	VOICE COIL
PC-5	C-1 .05 MFD. CONDENSER. 400V.	S	P.M. SPEAKER
PC-8	C-2 .1 MFD. CONDENSER. 400V.	PU-2	CRYSTAL CARTRIDGE
PC-7	C-3 .01 MFD. CONDENSER. 400V.		L-72
EC-5	C-4 10MFD. 25 V. } ELECTROLYTIC		
	C-5 12MFD. 150V. }		
	C-6 80MFD. 150V. }		

Trav-ler Radio Corp. Phonograph Models 7014 and 7015 are similar to Model 7000 described on page 154 of Volume 6, 1946 Diagram Manual.

TRAV-LER RADIO CORP.

Model 5028

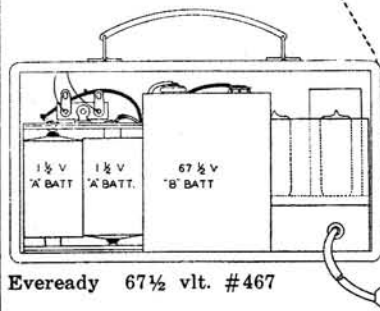

Eveready 67 1/2 vlt. #467

Burgess 67 1/2 vlt. #XX45

General 67 1/2 vlt. #W45A

Ray-O-Vac 67 1/2 vlt. #4367

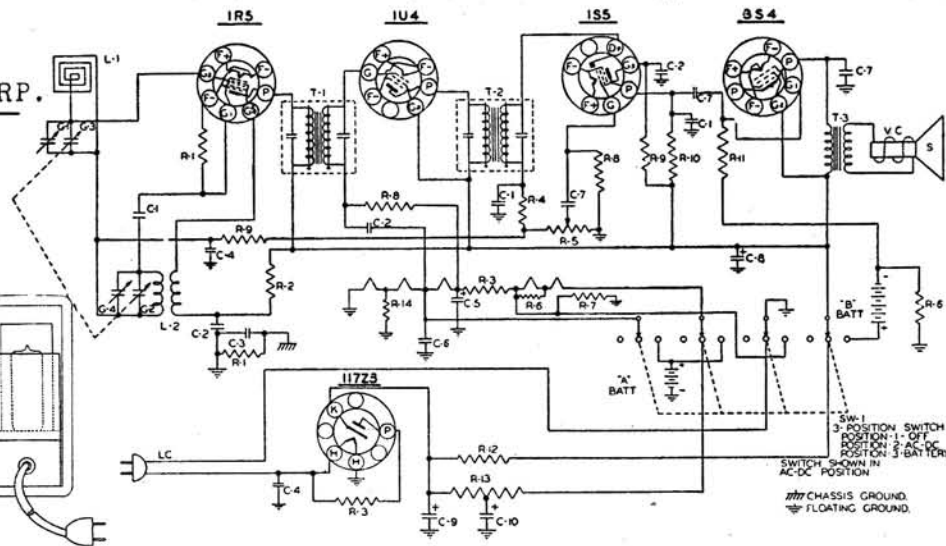

PART NO.	DESCRIPTION	PART NO.	DESCRIPTION	PART NO.	DESCRIPTION
IR-20	R-1 220M~ RESISTOR 1/2W 20%	PC-3	C-6 1 MFD. CONDENSER 200 W.V.	T-1	INPUT IF TRANSFORMER
IR-37	R-2 10M~ RESISTOR 1/2W 20%	PC-7	C-7 .005MFD CONDENSER 600 W.V.	LI-5	T-2
IR-17	R-3 33~ RESISTOR 1/2W 20%	C-8	40 MFD	T-3	SPEAKER OUTPUT TRANSFORMER
IR-31	R-4 82M~ RESISTOR 1/2W 20%	EC-44	C-9 40MFD 150 WV ELECTROLYTIC	VC	VOICE COIL
VC-11	R-5 220~ RESISTOR 1/2W 10%	C-10	20MFD.	S	3 1/2 PM SPEAKER
IR-11	R-6 1MEG. VOLUME CONTROL				
IR-33	R-7 520~ RESISTOR 1/2W 5%				
IR-39	R-8 10M~ RESISTOR 1/2W 20%	G-1	ANT TRIMMER		
IR-3	R-9 330K~ RESISTOR 1/2W 20%	CC-6X	GANG CONDENSER		
IR-13	R-10 10M~ RESISTOR 1/2W 20%	G-2	JSC TRIMMER		
IR-12	R-11 3.3MEG~ RESISTOR 1/2W 20%	G-3			
IR-15	R-12 100~ RESISTOR 1/2W 20%	G-4			
IR-2	R-13 100~ RESISTOR 1/2W 20%				
IR-11	R-14 250-1050 OHM OHM RESISTOR 5W 5%	LL-14	L-1 LOOP ANTENNA	X BATT	2'D SIZE 1 1/2 VOLT FLASHLAMP CELLS
IR-1	R-14 470~ RESISTOR 1/2 20%	LD-8	L-2 OSC COIL	B BATT	1-6 7 1/2 VOLT BATTERY
MC-2	C-1 200MFD MICA CONDENSER	CO-1	LC LINE CORD		
PC-7	C-2 0.1MFD CONDENSER 400W.V.	SW-8	SW-1 4 POLE-3 POSITION SWITCH		
PC-8	C-3 110P1 CONDENSER 400W.V.				
PC-5	C-4 .05MFD CONDENSER 400W.V.				
EC-6	C-5 7MFD 50V ELECTROLYTIC				

172

I.F. 455 KC.

MANUAL OF 1948 MOST-OFTEN-NEEDED RADIO DIAGRAMS

UNITED MOTORS SERVICE

DIVISION OF GENERAL MOTORS CORPORATION

Buick Models 980744 and 980745
For diagram see page 175.

PUSH BUTTON SET-UP

Release holding spring in bottom of button, pull button off. Loosen re-set screw and push in until it bottoms. Tune in desired station while holding in re-set screw. Release and tighten screw. Replace button.

ALIGNMENT PROCEDURE

Volume Control Maximum.

Signal Generator output minimum for satisfactory output indication.



MODEL 980744

Series Condenser or Dummy Antenna	Connect To	Tune Receiver To	Signal Generator Frequency	Adjust Screws In Order
0.1 Mfd.	6SA7 Pin #8	No Broadcast Sig.	262 KC	A B C D
*.000060 Mfd.	Antenna Connector	Extreme Hi. Freq.	1615 KC	E F G
***.000060 Mfd.	Antenna Connector	Signal Generator	1430 KC	**J K

*Before making this adjustment turn core screws J, K, H by means of a bakelite screwdriver, so that the rear end of the cores are 1/16" from the rear of the coil form. The purpose of this adjustment is to set the cores at the correct starting point with respect to the windings.

**Cores J and K are adjusted by means of a bakelite screwdriver through the rear end of the coils. There must not be any metal in part of screwdriver inserted in the coil.

***Should it be necessary to calibrate the pointer after this adjustment, tune signal generator to 1300 KC and the receiver to the signal. Loosen dial cord pulley set screws and adjust pointer to 1300 KC. Tighten set screws.

Adjust trimmer G to match car antenna (at approx. 1400 KC) when radio is installed.

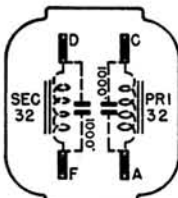

1st I. F. TRANS.

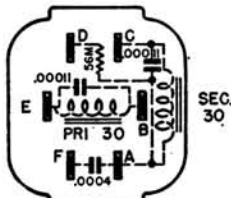

2nd I. F. TRANS.

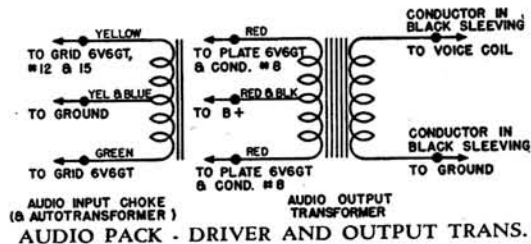

AUDIO PACK - DRIVER AND OUTPUT TRANS.

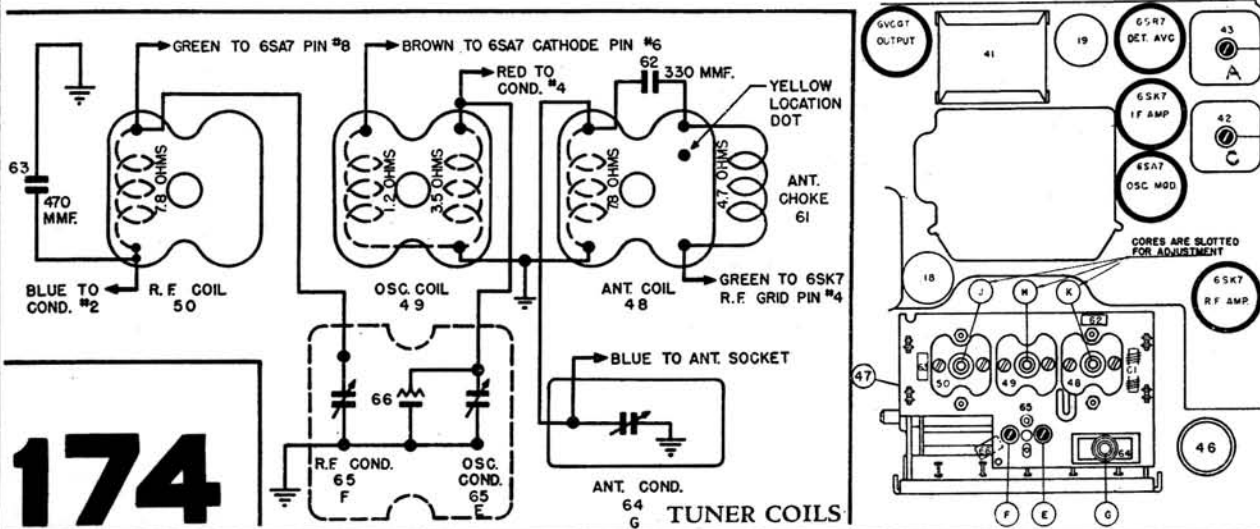

MANUAL OF 1948 MOST-OFTEN-NEEDED RADIO DIAGRAMS

CHASSIS VIEW

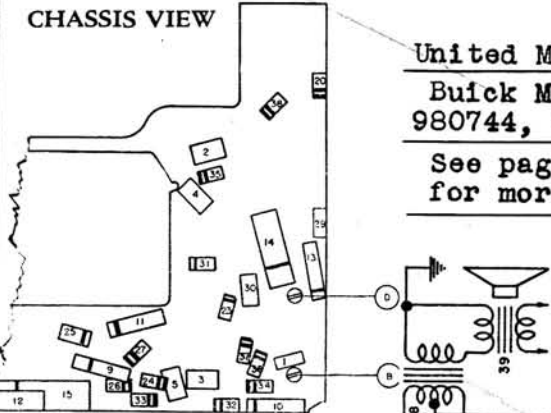

United Motors
 Buick Models
 980744, 980745
 See page 174
 for more data

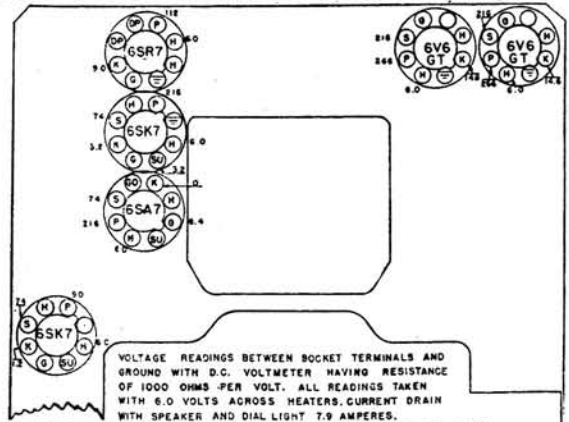

VOLTAGE READINGS BETWEEN SOCKET TERMINALS AND GROUND WITH D.C. VOLTMETER HAVING RESISTANCE OF 1000 OHMS PER VOLT. ALL READINGS TAKEN WITH 6.0 VOLTS ACROSS HEATERS. CURRENT DRAIN WITH SPEAKER AND DIAL LIGHT 7.9 AMPERES.

TOLERANCE ON VOLTAGES ± 10%

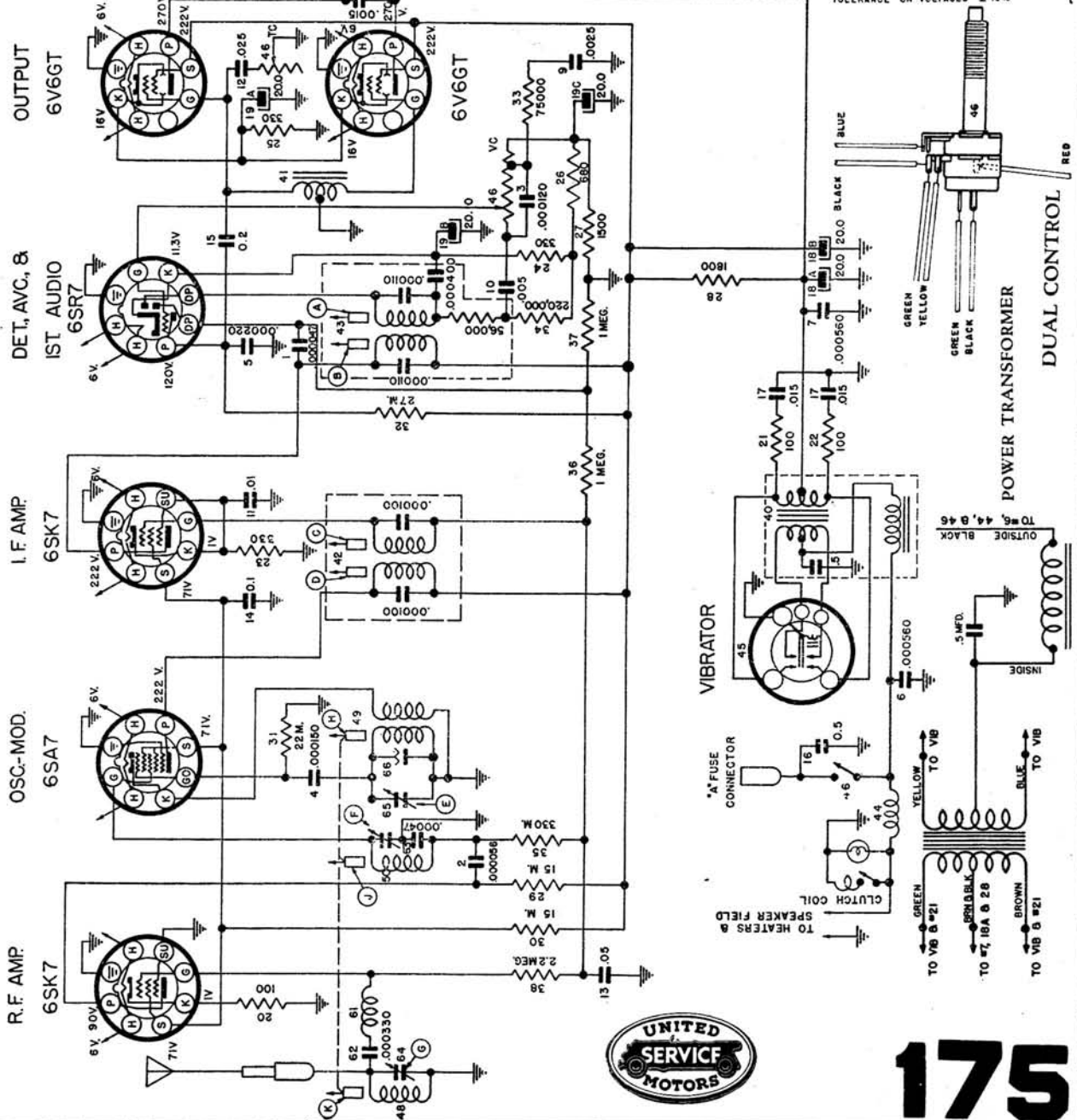

MANUAL OF 1948 MOST-OFTEN-NEEDED RADIO DIAGRAMS

WARWICK MANUFACTURING CORPORATION

Model C110

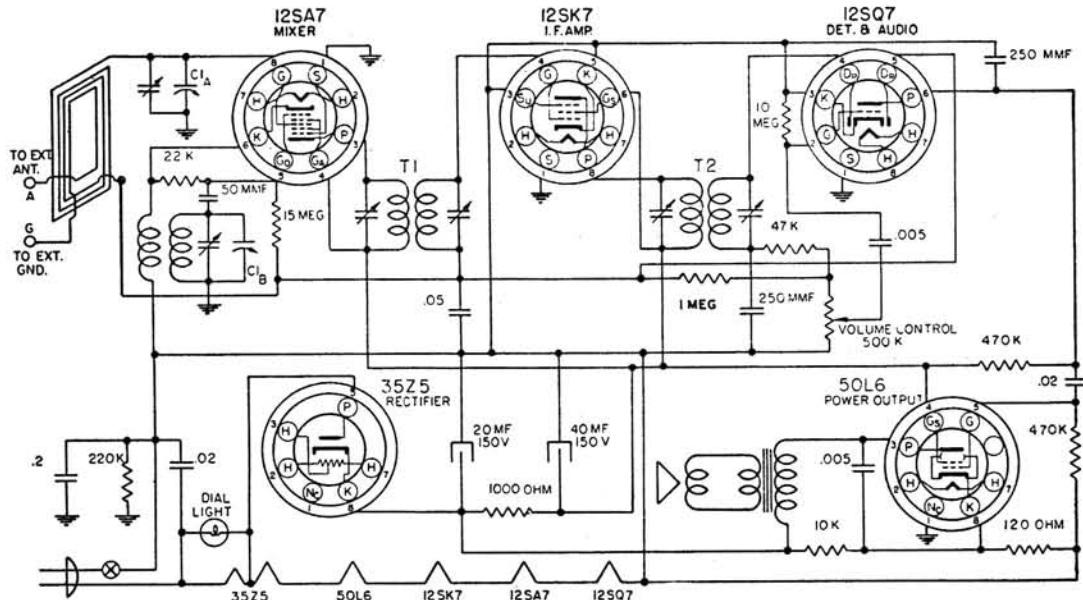

Position of Variable	Generator Frequency	Dummy Ant. Mid.	Generator Connections	Trimmer Adjustment	Trimmer Function
Fully open	455 KC	.1	* 12SA7 Grid (Stator of C1A)	T1	Input I.F.
Fully open	455 KC	.1	* 12SA7 Grid (Stator of C1A)	T2	Output I.F.
Fully open	1725 KC	.00025	** Ant. terminal on loop	C1B	Oscillator
Tune in signal from generator	1500 KC	.00025	** Ant. terminal on loop	C1A	Antenna

* Connect ground lead of signal generator to chassis.
 ** Connect ground lead of signal generator to terminal marked "G" on the back of the loop.



WARWICK MANUFACTURING CORPORATION Model 11011

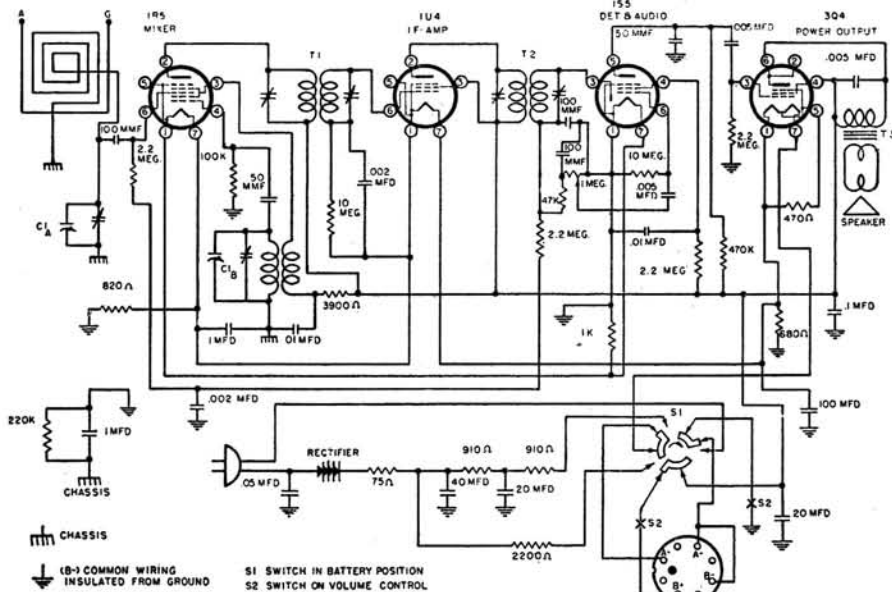
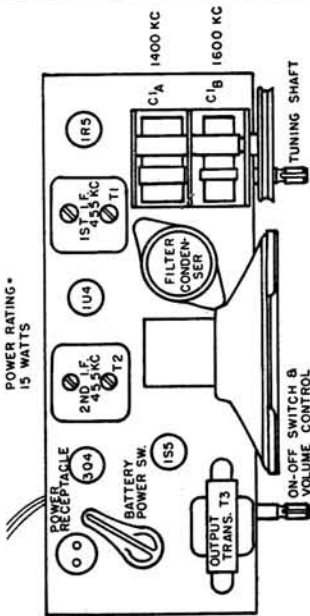

CHASSIS
 (B) COMMON WIRING INSULATED FROM GROUND
 S1 SWITCH IN BATTERY POSITION
 S2 SWITCH ON VOLUME CONTROL

PRONG VIEW OF BATTERY PLUG

176

MANUAL OF 1948 MOST-OFTEN-NEEDED RADIO DIAGRAMS

WESTERN AUTO SUPPLY COMPANY

MODELS D1747 & D1748

ALIGNMENT PROCEDURE

Continued from page 177

MECHANICAL ADJUSTMENT—The core tuning bar (see illustration of iron cores) and dial pointer must be adjusted mechanically before any electrical alignment is attempted. Rotate the manual tuning control until the core bar is farthest from the coils. For proper adjustment the bar should be approximately 1/32 of an inch from the two rod guide angles.

With the core bar in this position, adjust the dial pointer to coincide with 1600 kc on the dial scale.

Rotate the cores of each of the three broadcast coils (see illustration) until the end of the coil is 1-5/32" from the end of the coil form. Rotate the three 9-mc cores until this dimension is 1-1/16" for these coils. After these adjustments have been made, the unit can be aligned electrically.

ELECTRICAL ADJUSTMENT—To align the set make the following preliminary adjustments: Set the tone control for treble tone; set the volume control at maximum; connect the ground post of the signal generator to the radio chassis; connect the output meter across a 3.2-ohm output load; and allow the receiver and signal generator to warm up for several minutes.

Align the set according to the sequence given in the chart. The indicated dummy antenna is to be connected in series between the signal generator output lead and the receiver. Adjust the set for maximum output; reduce the input as needed to keep the output near 1.3 volts.

Locations of all trimmers and coils are shown elsewhere in this manual. After adjustment, seal the coil cores with colodion or a similar substance (do not use cement).

BAND SWITCH SETTING	SIGNAL GENERATOR			DIAL POINTER SETTING	ADJUST TO MAXIMUM OUTPUT (in order shown)
	Frequency	Coupling Capacitor	Connection to Radio		
Broadcast (for I. F.)	455 kc	.1 mf	Grid (pin 8) of converter (6SA7)	1600 kc	Trimmers on output and input I. F. cans
Broadcast	1600 kc	200 mmf	Antenna lead	1600 kc	BC Osc. trimmer C15 BC R. F. trimmer C8 BC Ant. trimmer C2
	1400 kc	200 mmf	Antenna lead	1400 kc	Rotate cores of BC R. F. coil T7 and BC Ant. coil T1
31 Meter	9.6 mc	400 ohms	Antenna lead	9.6 mc	9 mc Osc. trimmer C14 9 mc R. F. trimmer C9 9 mc Ant. trimmer C3
49 Meter	6.1 mc	400 ohms	Antenna lead	6.1 mc	6 mc Osc. coil T14 6 mc R. F. coil T10 6 mc Ant. coil T4
25 Meter	11.8 mc	400 ohms	Antenna lead	11.8 mc	12 mc Osc. coil T13 12 mc R. F. coil T8 12 mc Ant. coil T2
19 Meter	15.2 mc	400 ohms	Antenna lead	15.2 mc	15 mc Osc. coil T12 15 mc R. F. coil T9 15 mc Ant. coil T3

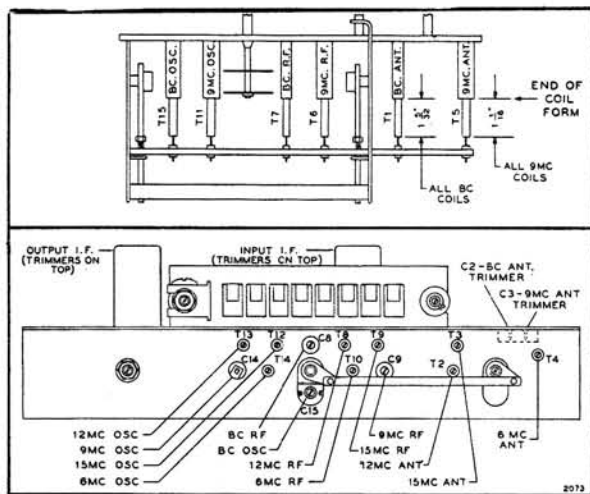

Coils and Trimmers

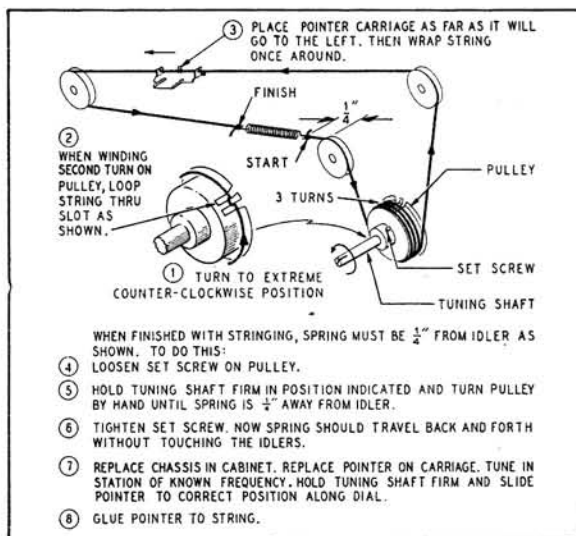

Replacement of Drive Cord

MANUAL OF 1948 MOST-OFTEN-NEEDED RADIO DIAGRAMS

TRUETONE

MODEL D-2634

ALIGNMENT—Sets are properly aligned at the factory with precision equipment and the adjustments should not be disturbed unless a coil, tuning condenser or IF transformer has to be replaced or the set has been subject to damage or tampering. Alignment should only be done with the aid of an accurate signal generator and output indicating instrument.

TO PROPERLY ALIGN—Remove chassis from cabinet, and align I. F. Transformers in the conventional manner with a Signal Generator adjusted to 455 KC, connected to the grid of the 6SA7 through a .1 Mfd. condenser, with the tuning condenser set at minimum capacity. To align tuning condenser, carefully place loop in normal relation to chassis, connect Signal Generator to antenna clip through a .0001 Mfd. condenser. Adjust oscillator trimmer condenser (located on left top) to 1620 KC with tuning condenser at minimum capacity (complete out of mesh). The antenna and R. F. sections are trimmed at 1400 KC. Antenna trimmer is top right; R. F. trimmer is below at right. Dial pointer may be adjusted to scale by slipping pointer coupling on dial cord.

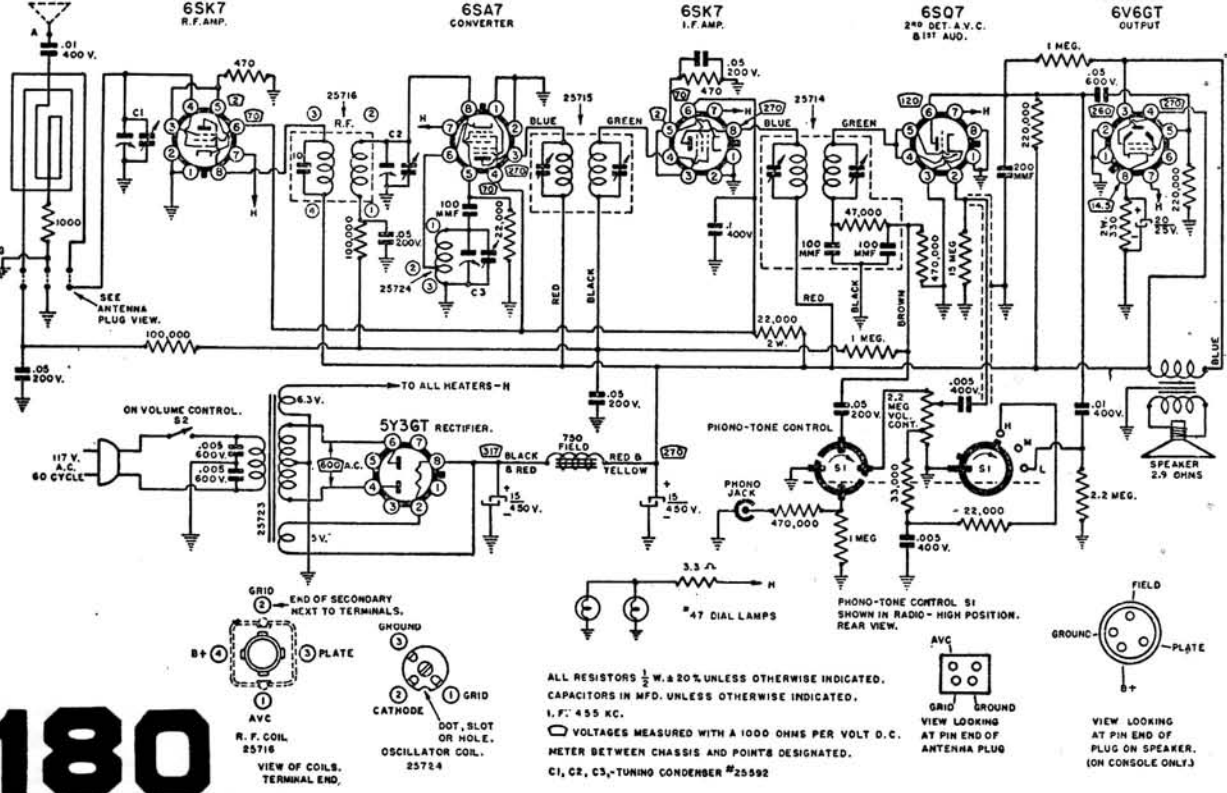
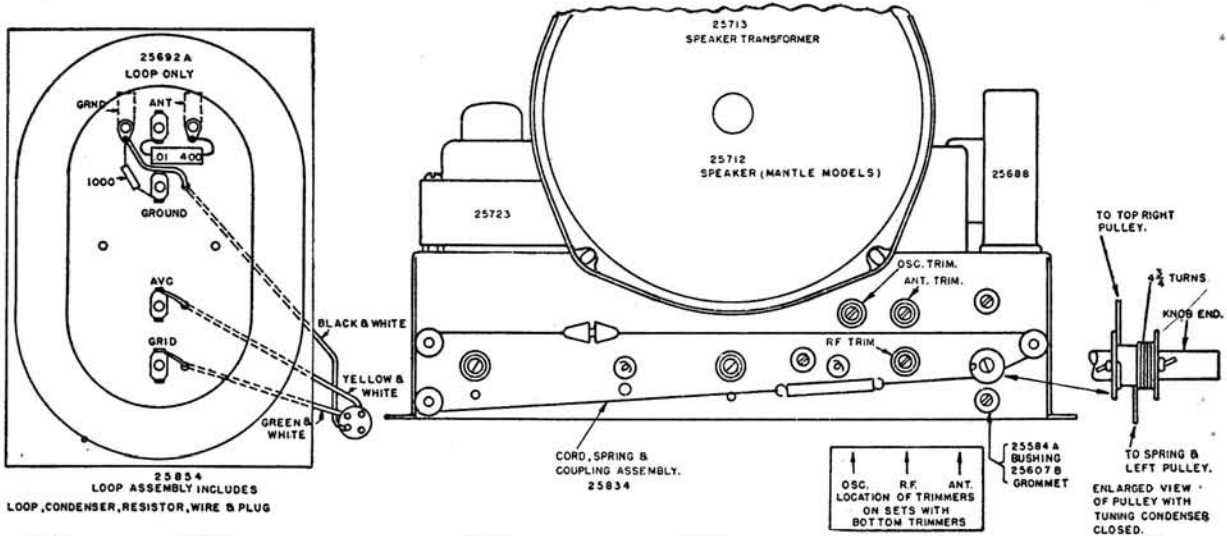

MANUAL OF 1948 MOST-OFTEN-NEEDED RADIO DIAGRAMS

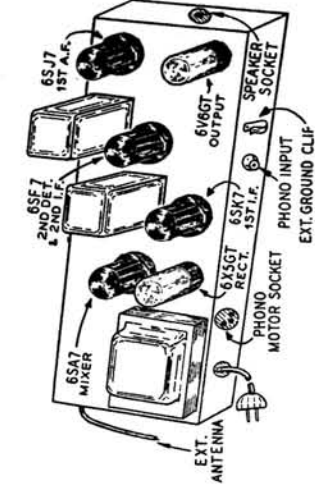
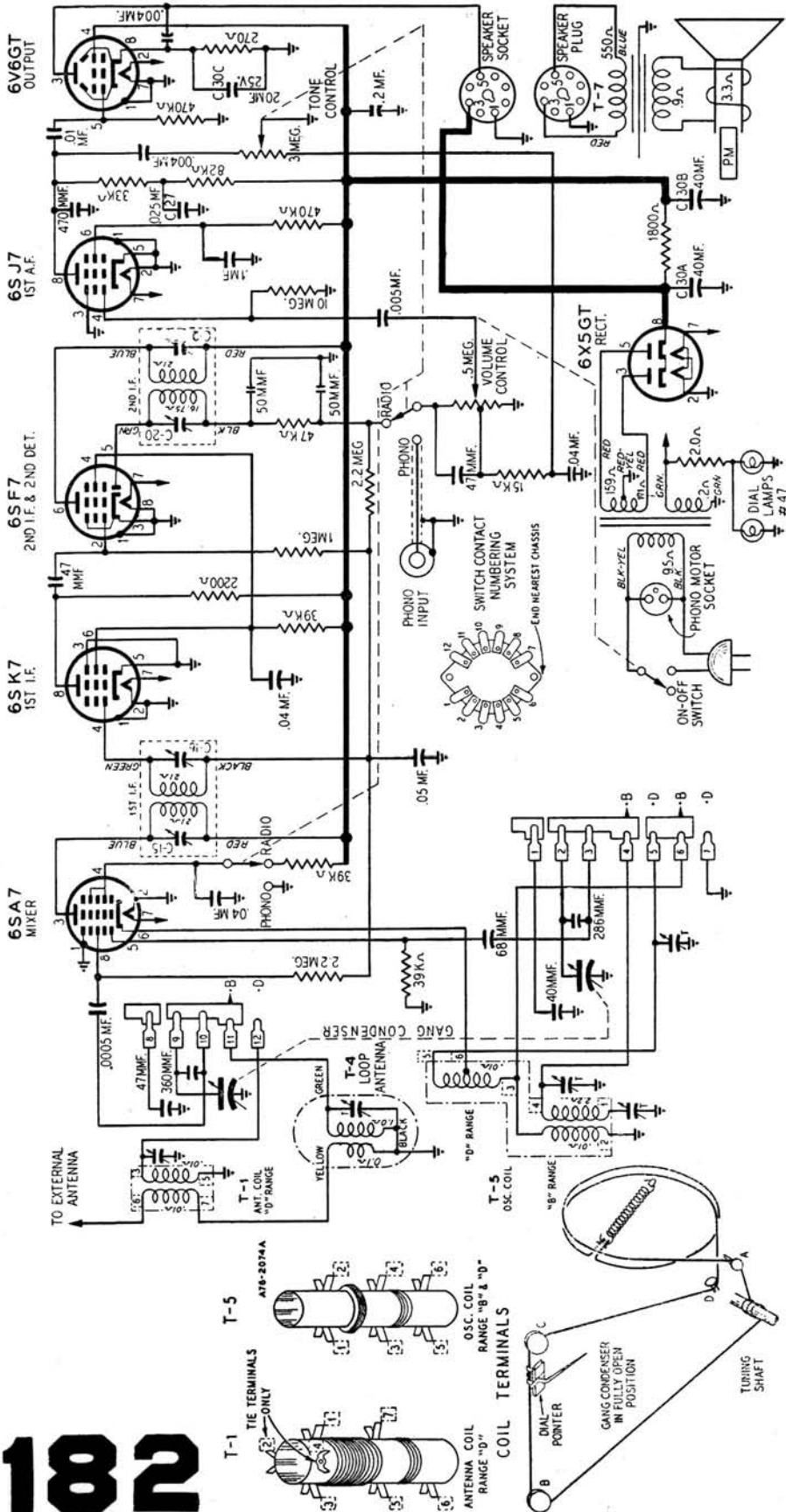

Western Auto
TRUETONE
Model D-2745

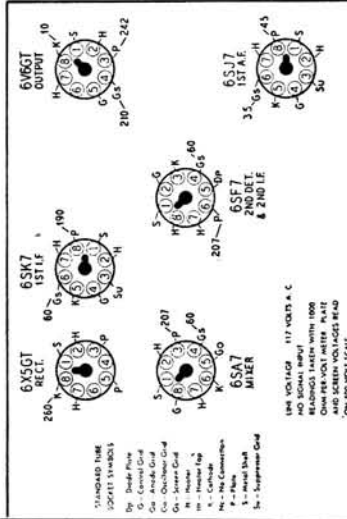
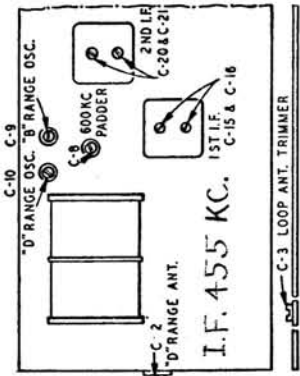

MANUAL OF 1948 MOST-OFTEN-NEEDED RADIO DIAGRAMS

Westinghouse Electric

MODEL H-148

INTERMEDIATE FREQUENCY 455 KC.

1. SWITCHES "3W, 2-3-4-5" ARE SHOWN IN A.C. POSITION.
2. VOLTAGES MEASURED FROM COMMON NEGATIVE USING
A 20,000 OHM/VOLT METER. (A.C. OPERATION - 115 V. LINE.)

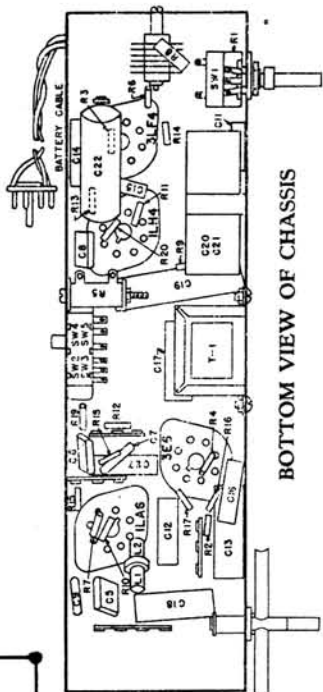
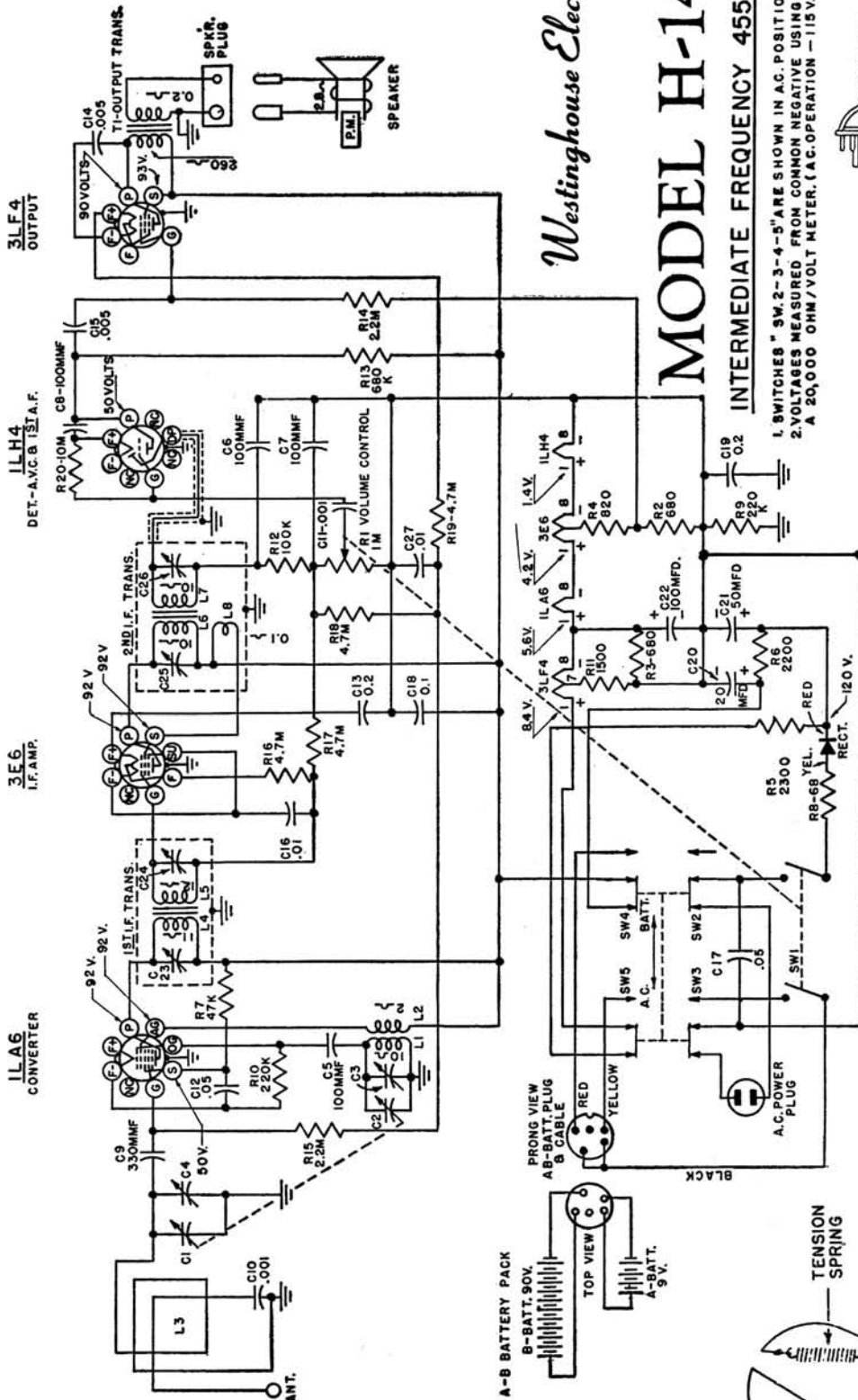

BOTTOM VIEW OF CHASSIS

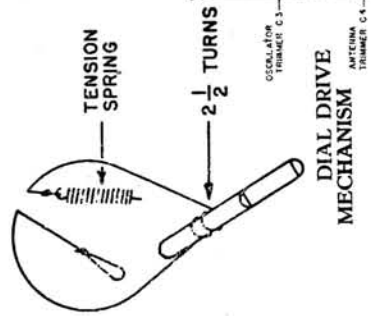
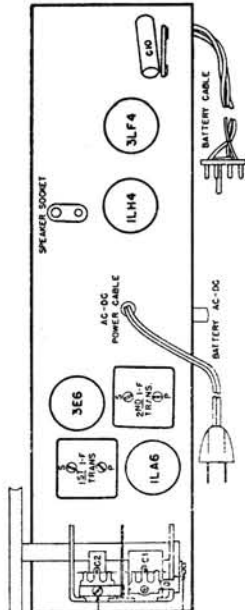

MANUAL OF 1948 MOST-OFTEN-NEEDED RADIO DIAGRAMS

MODEL 5G036 CHASSIS No. 5C51



186

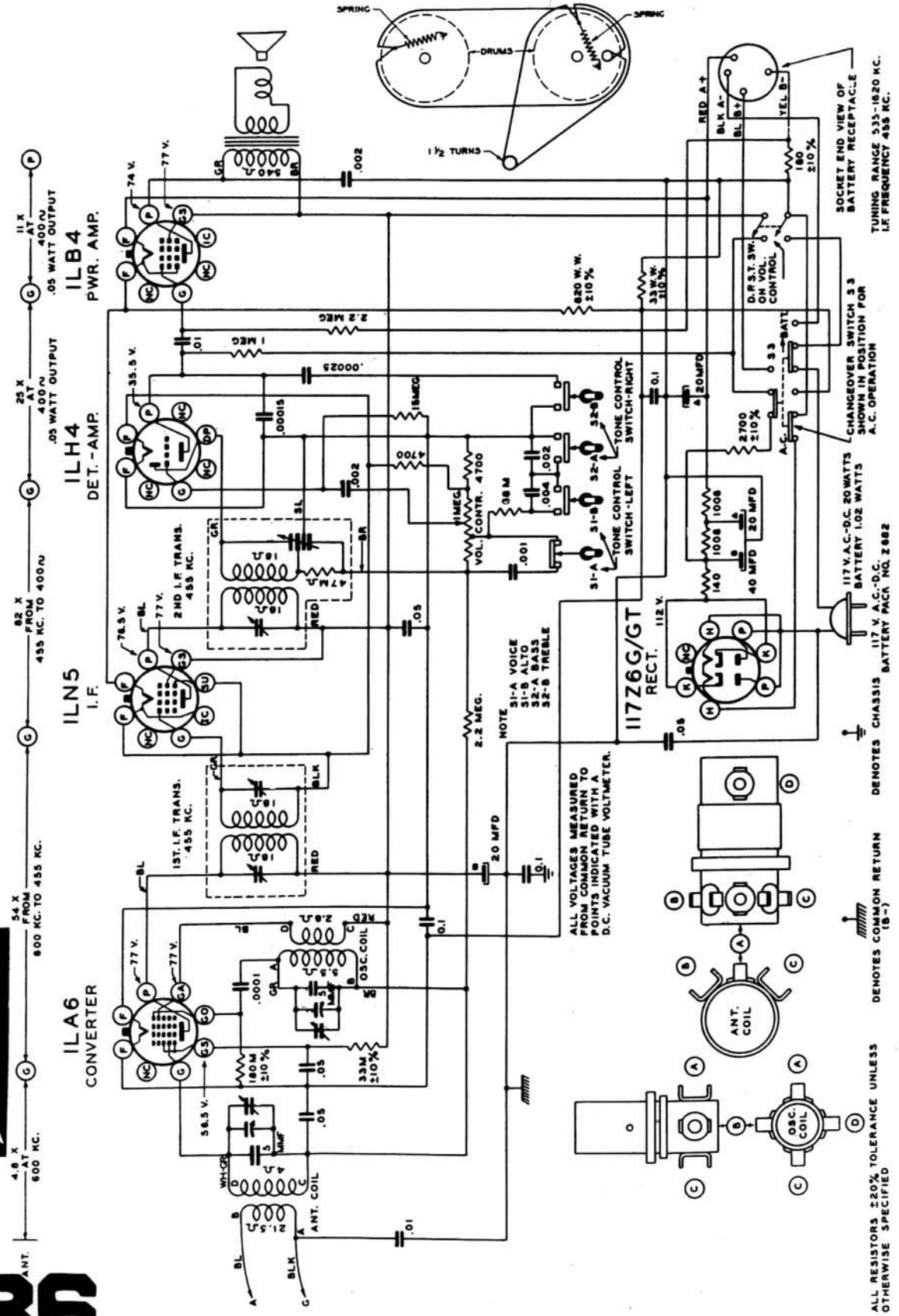

MANUAL OF 1948 MOST-OFTEN-NEEDED RADIO DIAGRAMS

ALL VOLTAGES MEASURED FROM COMMON RETURN TO POINTS INDICATED WITH AN AC.DC. OR VACUUM TUBE VOLTMETER AS REQUIRED.

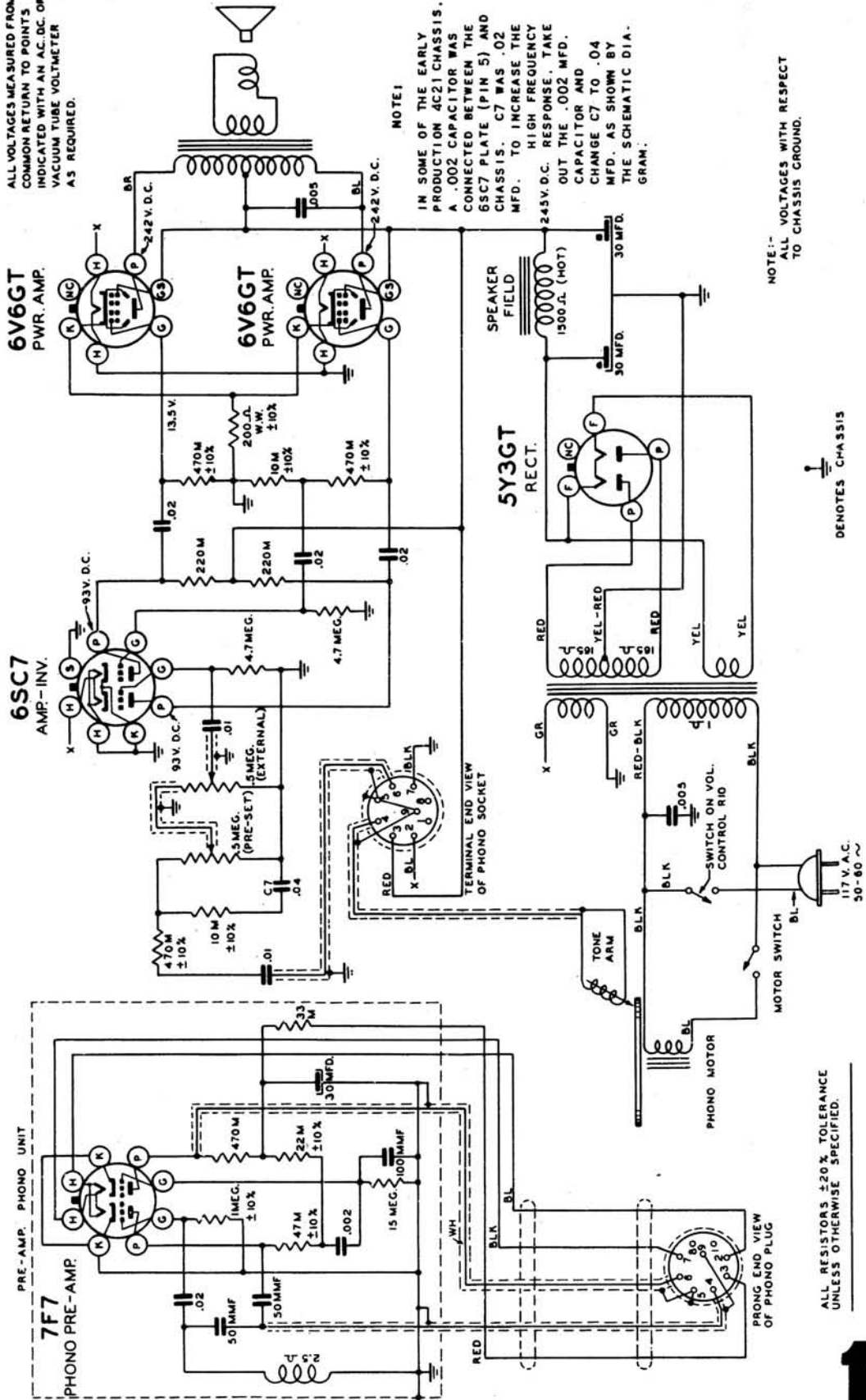

MODEL S 1 2 6 0 0
CHASSIS No. 4 C 2 1



MANUAL OF 1948 MOST-OFTEN-NEEDED RADIO DIAGRAMS

Zenith Radio Corp.
Schematic on page 188

MODELS 4K040-4K040G
CHASSIS No. 4C54

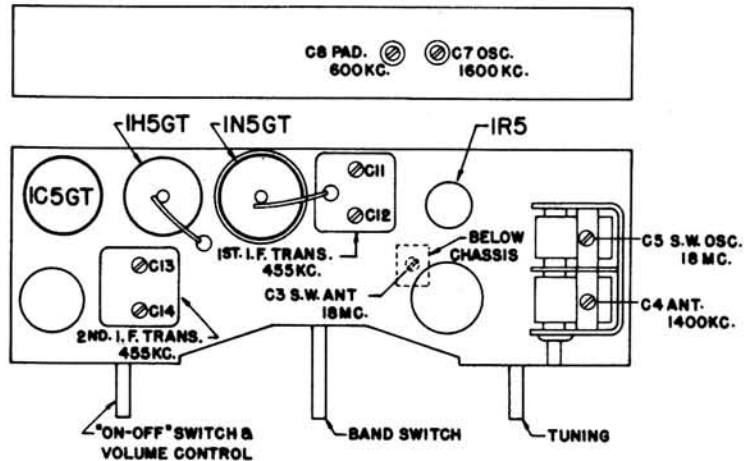
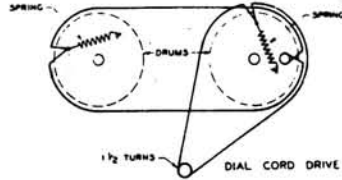

ALIGNMENT PROCEDURE

OPERATION	CONNECT OSC. TO	DUMMY ANT.	INPUT SIG. FREQUENCY	BAND	SET DIAL AT	TRIMMERS
1	Converter Grid	.5 Mfd.	455 Kc.	BC	600 Kc.	C-11, C-12, C-13, C-14
2	Ant.-Gnd.	400 ohms	18 Mc.	SW	18 Mc.	C-5
3	Ant.-Gnd.	400 ohms	400 ohms	SW	Rock Gang 18 Mc.	C-3
4	Ant.-Gnd.	200 Mmf.	1600 Kc.	BC	1600 Kc.	C-7
5	Ant.-Gnd.	200 Mmf.	1400 Kc.	BC	1400 Kc.	C-4
6	Ant.-Gnd.	200 Mmf.	600 Kc.	BC	Rock Gang 600 Kc.	C-8

Zenith Radio Corp. Changes between Chassis 11C21 and Chassis 11C21Z shown in circuit diagrams below. For complete receiver diagram and alignment see pages 190 to 192, in Volume 6, 1946 Diagram Manual.

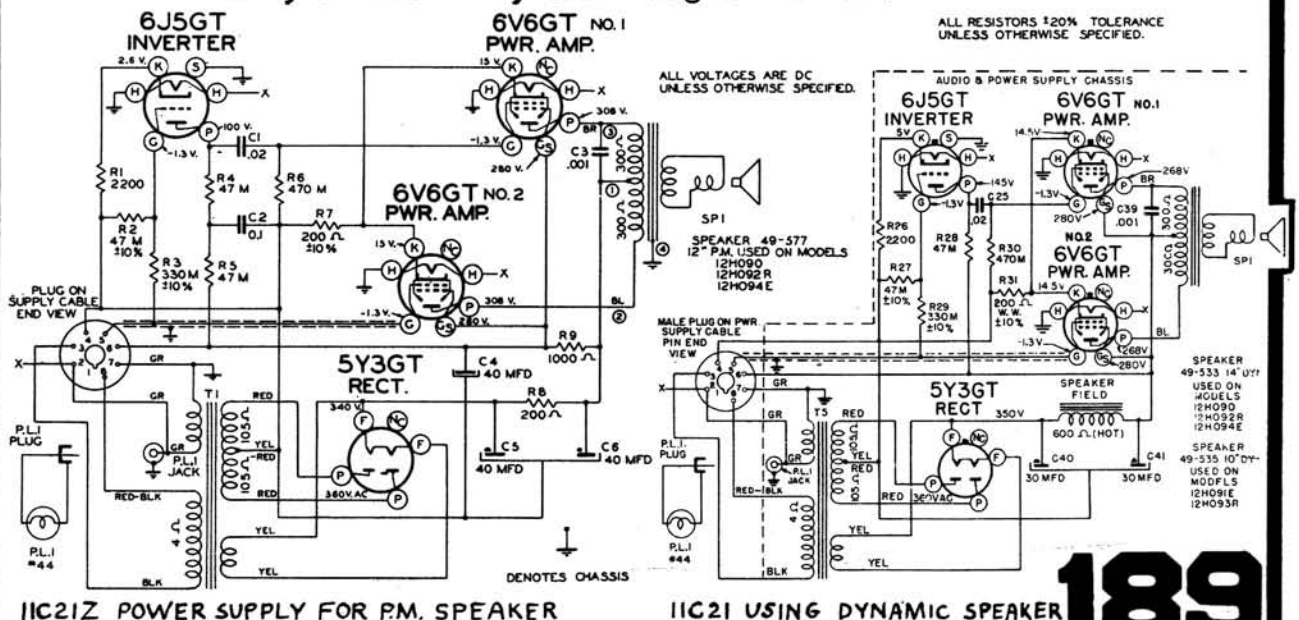

MANUAL OF 1948 MOST-OFTEN-NEEDED RADIO DIAGRAMS

Zenith Radio Corp.
Diagram on page 190

MODEL 5G003
CHASSIS No. 5C40

The alignment of chassis 5C40 is conventional and the most accurate alignment will be accomplished if the procedure is followed exactly. The IF frequency is 455 KC and all measurements, voltage, and resistance have been taken with an electronic voltohmmeter.

Stage by stage gain measurements are for reference purposes only. Gain measurements can seldom be duplicated, and are used only for comparison purposes.

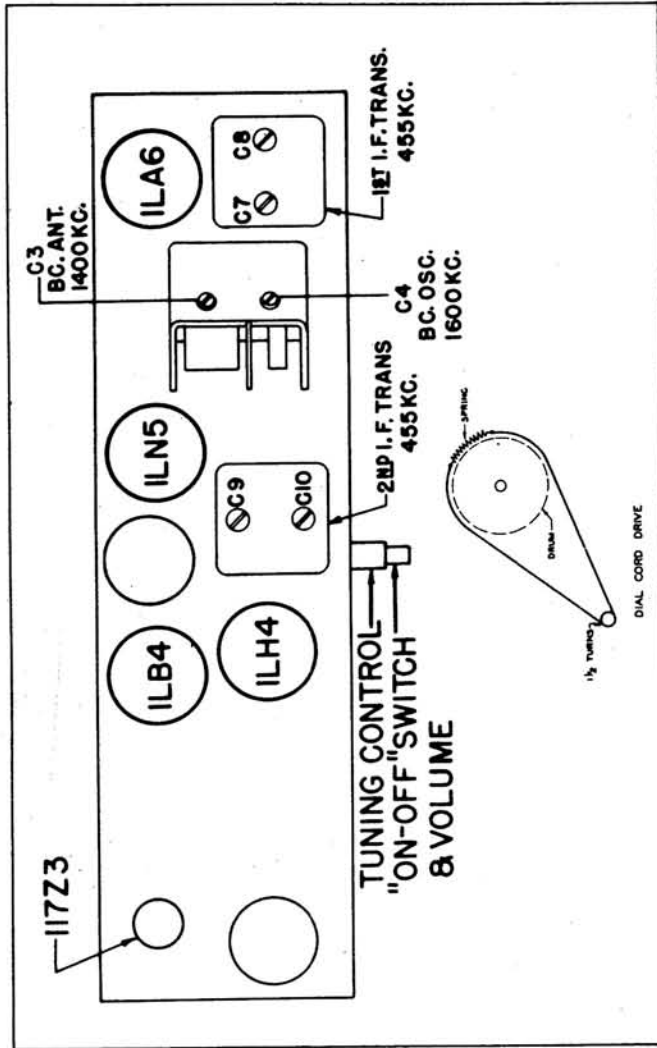

TUBE TRIMMER LOCATION AND DIAL CABLE DRAWING

ALIGNMENT PROCEDURE

OPERATION	CONNECT OSC. TO	DUMMY ANT.	INPUT SIG. FREQUENCY	SET DIAL AT	TRIMMERS	PURPOSE
1	Converter Grid	.5 Mfd.	455	600	C7, C8, C9 and C10	I.F. Alignment
2	Single Turn Loop	--	1600	1600	C4	Set Osc. to scale
3	Coupled Loosely to Wavemagnet	--	1400	1400	C3	Alignment of Antenna

