

MODIFICATION KIT

FOR THE



SB-104 SINGLE SIDEBAND TRANSCEIVER

MODEL SBM-104-1

The purpose of this Modification Kit is to improve the sensitivity of the receiver section of your Model SB-104 Single Sideband Transceiver. After you make this modification, your Transceiver will be updated to reflect the latest Heathkit engineering improvements.

PARTS LIST

KEY PART No.	PART No.	QTY.	DESCRIPTION	CIRCUIT Comp. No.
A1	40-1875	1	4.5 μ H inductor (red dot)	L734
A2	45-73	1	2.2 μ H inductor	RFC701
B1	417-274	2	40673 transistor	Q701, Q702
		1	Instruction sheet	

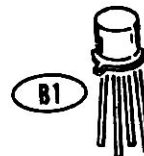
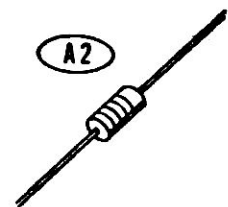
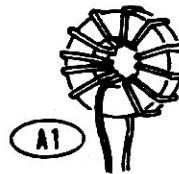



GENERAL

The illustrations referred to in the following steps are Pictorials in your Model SB-104 Transceiver Manuals, unless otherwise indicated.

To identify the location of any part, refer to the Schematic Diagram and the X-Ray Views in your SB-104 Transceiver Manuals.

Refer to Pictorial 12-41 (fold-out from Page 244 in the Operation Manual) for the following two steps.

- () Remove the two 10-32 x 1/2" screws from each side panel. Set the screws, flat washers, and the cabinet retainer strips aside for use later.
- () Remove the cabinet shells from the chassis. Temporarily set the cabinet shells aside.

CHASSIS

() Refer to Pictorial 12-6 (on Page 184 in the Assembly Manual) and disconnect the red wire between terminals G2 and G13. Discard this wire.

Refer to Pictorial 12-22 of this Modification Kit for the following three steps.

() Cut the orange wire 2-1/2" from where it leaves BO#7.

- () Connect the free end of the orange wire, coming from the harness, to terminal G2 (NS).
- () Connect the orange wire, that was cut off the harness wire to terminal G2 (S-2).

RECEIVER FRONT END CIRCUIT BOARD

NOTE: After you install and solder each component in the following steps, cut off and discard the excess lead lengths.

Refer to the X-Ray View (fold-out from Page 308 in the Operational Manual) for the location of the parts in the following steps.

- () Remove the 100 Ω (brown-black-brown) resistor at R719.
- () Install a 2.2 μ H inductor (#45-73) at R719. Your circuit board is marked 100 at this location.
- () Remove the 7.6 μ H inductor at L734. This inductor may have white and red color dots.
- () Install a 4.5 μ H inductor (#40-1875, red dot) at L734.

- () Remove the 40673 transistor (#417-240) at Q701.
- () Install a 40673 transistor (#417-274) at Q701. After you install this transistor, remove the shorting wire from the transistor leads.
- () Remove the 40673 transistor (#417-240) at Q704.
- () Install a 40S73 transistor (#417-274) at Q704. After you install this transistor, remove the shorting wire from the transistor leads.
- () Reinstall the cabinet shells and the cabinet retainer strips.

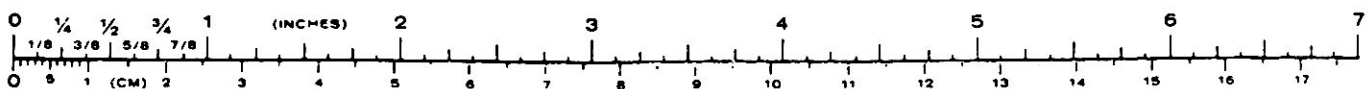

MODIFICATION KIT

FOR THE



SB-104 SINGLE SIDEBAND TRANSCEIVER

MODEL SBM-104-2

The purpose of the Modification Kit is to update your SB-104 Transceiver to reflect all the latest Heathkit engineering improvements. When the changes are completed, your Transceiver will be identical to the Heathkit SB-104A Transceiver.

PARTS LIST

Check each part against the following list. Any part that is packed in an individual envelope with the part number on it should be placed back in the envelope after you identify it until it is called for in a step. The key numbers correspond to the numbers on the Parts Pictorial.

To order a replacement part, always include the PART NUMBER. Use a Parts Order Form, or, if one is not available, refer to "Replacement Parts" inside the rear cover of your Transceiver Manual. For prices, refer to the separate "Heath Parts Price List."

NOTE: The circuit component numbers refer to the component numbers in the SB-104A Manual and Schematic.

KEY No.	HEATH Part No.	QTY.	DESCRIPTION	CIRCUIT Comp. No.
---------	----------------	------	-------------	-------------------

RESISTORS 1/4-Watt

NOTE: The following resistors have a tolerance of 10% unless they are listed otherwise. 10% is indicated by a fourth color band of silver. 5% is indicated by a fourth color band of gold.

A1	1-1-12	4	100 Ω (brown-black-brown)	R343, R345, R619, R621
A1	1-61-12	1	180 Ω , 5% (brown-gray-brown)	R13
A1	1-23-12	1	390 Ω (orange-white-brown)	R314
A1	1-2-12	1	1000 Ω (brown-black-red)	R684
A1	1-74-12	1	3300 Ω (orange-orange-red)	R321
A1	1-26-12	3	5600 Ω (green-blue-red)	R612, R677, R679
A1	1-78-12	1	6800 Ω , 5% (blue-gray-red)	R322
A1	1-14-12	1	12 k Ω (brown-red-orange)	R329
A1	1-45-12	1	22 k Ω (red-red-orange)	R625

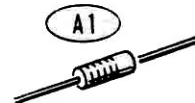

HEATH COMPANY
BENTON HARBOR, MICHIGAN 49022

595-2016-01



KEY No.	HEATH Part No.	QTY.	DESCRIPTION	CIRCUIT Comp. No.
1/2-Watt				
A2	1-49	1	22 Ω (red-red-black)	R22
A2	1-1	2	47 Ω (yellow-violet-black)	R23, R1237
A2	1-3	2	100 Ω (brown-black-brown)	R1253
				R1254
A2	1-111	2	150 Ω (brown-green-brown)	R21, R1206
A2	1-6	1	470 Ω (yellow-violet-brown)	R1203
A2	1-96	1	750 Ω, 5% (violet-green-brown)	R254
A2	1-10	1	1200 Ω (brown-red-red)	R1201
A2	1-14	1	3300 Ω (orange-orange-red)	R1231
A2	1-21	2	15 kΩ (brown-green-orange)	R407, R507
A2	1-22	2	22 kΩ (red-red-orange)	R1251, R1252
A2	1-24	1	33 kΩ (orange-orange-orange)	R209
A2	1-26	1	100 kΩ (brown-black-yellow)	R568
A2	1-126	2	180 kΩ (brown-gray-yellow)	R566, R567
A2	1-31	1	330 kΩ (orange-orange-yellow)	R564
A2	1-36	1	1.5 MΩ (brown-green-green)	R207

Other Resistors

A3	2-49-11	1	6110 Ω, 1%, 1/8-watt	R328
A3	2-68-11	1	1210 Ω, 1%, 1/8-watt	R332
A4	1-12-1	1	15 Ω, 1-watt (brown-green-black)	R11
A4	1-1-1	1	470 Ω, 1-watt (yellow-violet-brown)	R904
A4	3-14-2	3	.15 Ω, 5%, 2-watt (brown-green-silver-gold)	R5, R594, R956
A4	3-1-2	1	.82 Ω, 5%, 2-watt (gray-red-silver-gold)	R532
A5	1-13-2	1	220 Ω, 2-watt (red-red-brown)	R903
A6	10-398	1	2000 Ω control	R1232

CAPACITORS

Mica

B1	20-118	4	15 pF	C334, C337, C358, C361
B1	20-97	1	50 pF	C332
B1	20-109	2	62 pF	C342, C645
B1	20-119	1	90 pF	C831
B1	20-162	2	105 pF	C802, C804
B1	20-104	1	130 pF	C801
B1	20-189	1	140 pF	C348
B1	20-103	1	150 pF	C811
B1	20-120	1	220 pF	C336
B1	20-131	4	360 pF	C966, C967, C968, C969

KEY No.	HEATH Part No.	QTY.	DESCRIPTION	CIRCUIT Comp. No.
Mica (cont'd.)				
B1	20-106	1	390 pF	C369
B1	20-116	1	400 pF	C1233
B1	20-128	2	470 pF	C1229, C1231
B1	20-171	1	820 pF	C543
B1	20-172	2	1000 pF	C1253, C1254

Ceramic

B2	21-169	1	6 pF	C1202
B2	21-111	1	15 pF	C1216
B2	21-60	1	18 pF	C414
B2	21-7	1	33 pF	C441
B2	21-167	1	39 pF	C373
B2	21-190	1	50 pF	C1230
B2	21-21	1	200 pF	C1251
B2	21-56	1	470 pF	C1227
B2	21-140	3	.001 μF	C13, C15, C909
B2	21-176	7	.01 μF	C5, C17, C18, C22, C553, C1252, C1255

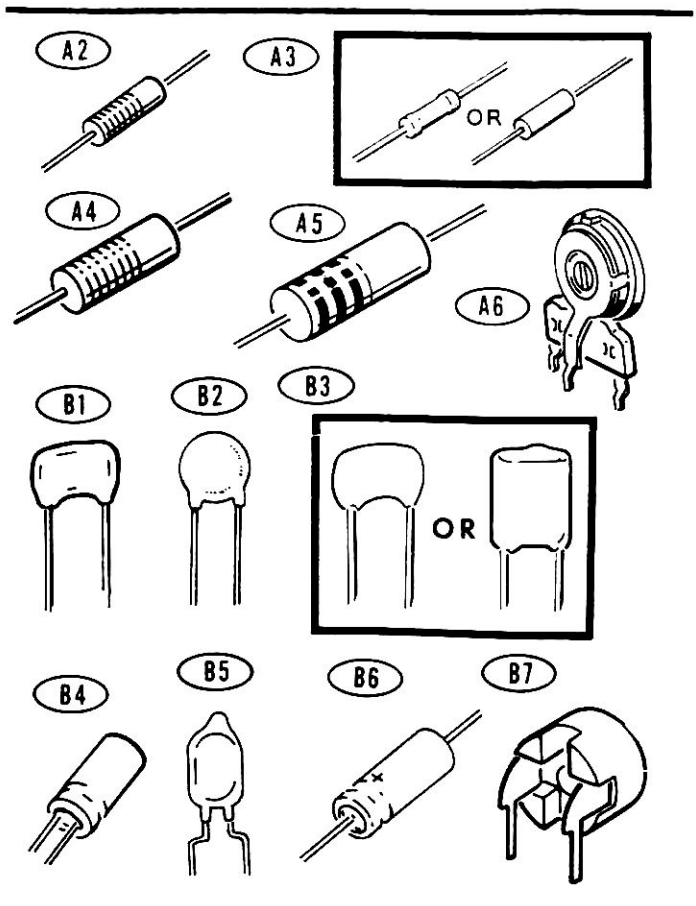

KEY HEATH QTY. DESCRIPTION
No. Part No.

CIRCUIT
Comp. No.

KEY HEATH QTY. DESCRIPTION
No. Part No.

CIRCUIT
Comp. No.

Other Capacitors

B3	27-47	9	.1 μ F Mylar*	C16, C19, C21, C23, C208, C222, C309, C319, C906
B4	25-149	1	5 μ F vertical electrolytic	C14
B5	25-212	1	22 μ F tantalum	C622
B5	25-223	1	47 μ F tantalum	C227
B6	25-54	1	10 μ F electrolytic	C1
B6	25-157	1	500 μ F electrolytic	C12
B6	25-219	1	1000 μ F electrolytic	C6
B7	31-71	1	3.5-18 pF trimmer	C333
B7	31-63	1	15-60 pF trimmer	C349

COIL—INDUCTORS— CHOKE

C1	40-1713	.2	.82 μ H peaking coil	L814, L815
C2	40-1865	1	.44 μ H (white and green dots) toroid	L803
C2	40-1869	2	1.31 μ H (green dot) toroid	L1251, L1253
C2	40-1872	1	2.3 μ H (green dot) toroid	L1252
C2	40-1877	1	13.25 μ H (white and yellow dots) toroid	L321
C3	45-82	1	350 μ H choke	RFC1201

DIODES — TRANSISTORS

D1	56-24	1	1N458 diode	D1201
D1	56-26	2	1N191 diode	D5, D6
D1	56-56	2	1N4149 diode	D1204
D1	56-89	1	GD510 diode	D7
D1	56-97	1	1N3017 zener	ZD1201
D2	417-134	1	MPS6520 transistor	Q210
D2	417-244	2	2N5089 transistor	Q302, Q303
D2	417-293	1	2N5770 transistor	Q1251
D3	417-274	1	40675 transistor	Q501

*DuPont Registered Trademark

MISCELLANEOUS

	85-1930-1	1	VFO/filter circuit board
	181-2203	1	Assembled receiver front end circuit board (G)
E1	205-1265	1	ALC/filter board shield
E2	205-1432-2	1	Panel trim strip
E3	258-95	1	Spring clip
	343-15	6"	Shielded cable
	344-52	8"	Red wire
	344-58	4'	Gray wire
	344-96	1'	Blue stranded wire
E4	350-12	1	Cement (tube)
E5	391-34	1	Blue and white label
E6	431-49	1	11-lug terminal strip
E7	475-10	3	Small ferrite bead
E8	475-12	4	Large ferrite bead
	490-185	6	Soder Wick**
	595-1992	1	SB-104A Assembly Manual
	595-1994	1	SB-104A Operation Manual SBM-104-2 Modification Manual (see Page 1 for Part Number.)

Solder

**Registered Trademark - Solder Removal Co.

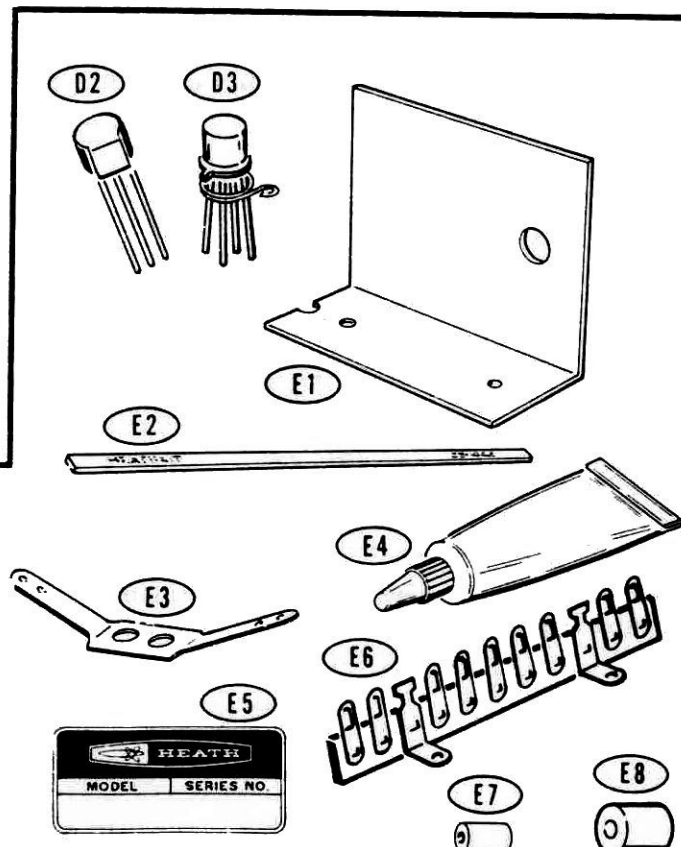
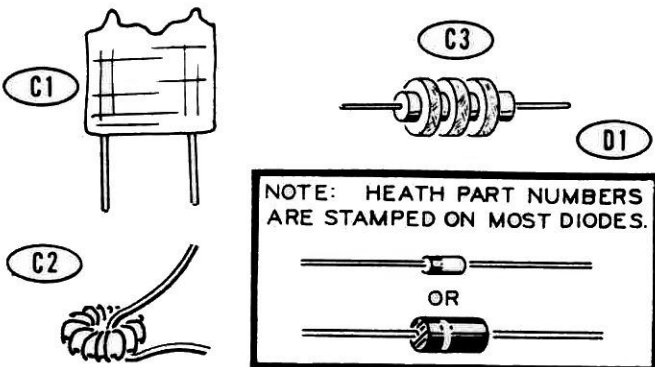



MODIFICATION PROCEDURE

This modification kit contains all of the current modifications for your SB-104 transceiver.

To make a modification, check each component in the following step-by-step assembly with the component installed in your kit. If the component in your kit is different from the one in this Manual, remove it from your kit and install the new one at the location shown. If the component shown in the Manual is the same as the one installed in your kit, disregard it and proceed to the next step. Be careful when you remove a component from a circuit board, or damage to the circuit foil will occur.

When you make a chassis connection, the indicated number of wires at the connection are shown in the solder instructions. For example, when you connect a

wire to a solder lug where two wires are already connected, the solder instructions will read (S-3). It may be necessary to remove any excess solder from a connection to make room for the new wire or component lead. Make sure you apply enough heat to the connection so that solder flows to each wire or component lead.

Do not make any connections, or install any components or circuit boards, until you are instructed to do so in a step.

When assembly or disassembly is required in a step, refer to your SB-104A Assembly Manual for the proper procedure.

START →

Perform the following steps to remove the VFO from your unit:

1. Remove the main tuning knob.
2. Remove the front jackson drive from the VFO.
3. Remove the four 6-32 × 3/8" hex-head screws which hold the VFO to the chassis. Set the hardware aside.
4. Remove the 4-pin female connector housing from the VFO.
5. Remove the VFO from the chassis.

() Refer to your SB-104A Assembly Manual, Pages 1-29 and 1-30, and disassemble the VFO. Separate both circuit boards from each other. Do not disconnect the wires going to the plug.

() Position the oscillator circuit board as shown.

NOTE: When you install the following diode, be sure to position the banded end as shown on the circuit board. Refer to Detail 1-1A.



() ZD1201: VR7.5 zener diode (#56-97). Install the banded end of the diode in circuit board hole E if a transistor was previously installed.

NOTE: When you install ceramic capacitors, do not push the insulated portion of the leads into the circuit board holes. This could make it difficult to solder the leads to the foil.

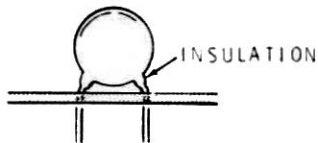

() C1216: 15 pF ceramic.

() C1202: 6 pF (N470) ceramic.

() C1203: 50 pF ceramic.

() Solder the leads to the foil and cut off the excess lead lengths.

VFO OSCILLATOR CIRCUIT BOARD

IMPORTANT: THE BANDED END OF DIODES CAN BE MARKED IN A NUMBER OF WAYS.

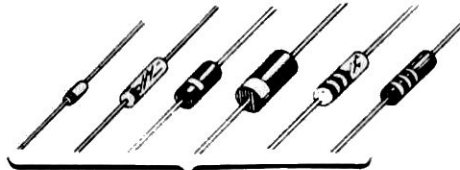

**BANDED END
Detail 1-1A**

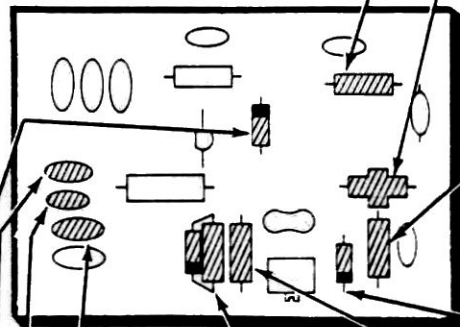

PICTORIAL 1-1

CONTINUE →

NOTE: If you already have a 150 Ω resistor installed at R1206, leave it installed regardless of the tolerance band and disregard the following step.

() R1206: 150 Ω (brown-green-brown).

() RFC1202: 350 μH choke (#45-82). Bend the leads toward the slot in the choke body to avoid placing any strain on the leads of the choke winding. Then install the choke as shown.

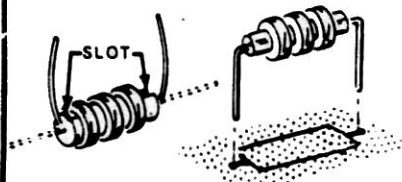

NOTE: Always install 1/2-watt resistors unless you are instructed otherwise.

() R1201: 1200 Ω (brown-red-red).

NOTE: When you install a diode, always match the band on the diode with the band mark on the circuit board.

() D1201: 1N458 diode (#56-24).

() R1203: 470 Ω (yellow-violet-brown).

() Wrap the leads of a 1N4149 diode (#56-56) around both leads of the 1 MΩ (brown-black-green) resistor as shown. Solder the leads together at the indicated locations. Make sure you position the banded end of the diode as shown.

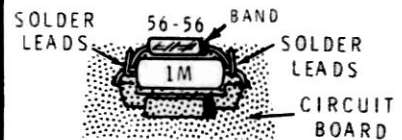

() R1203, D1204: 1 MΩ/1N4149 resistor-diode assembly.

() Solder the leads to the foil and cut off the excess lead lengths.

VFO BUFFER CIRCUIT BOARD

START →

() Position the VFO BUFFER circuit board as shown.

() R1231: 3300 Ω (orange-orange-red).

NOTE: When you install ceramic capacitors, do not push the insulated portion of the leads into the circuit board holes. This could make it difficult to solder the leads to the foil.

() C1227: 470 pF ceramic.

() R1232: 2000 Ω control.

() R1237: 47 Ω (yellow-violet-black).

() C1229: 470 pF mica.

() C1231: 470 pF mica.

() C1233: 400 pF mica.

() Solder the leads to the foil and cut off the excess lead lengths.

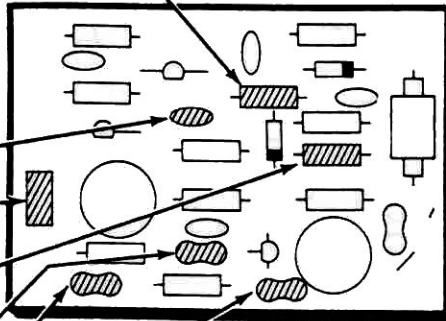

PICTORIAL 1-2

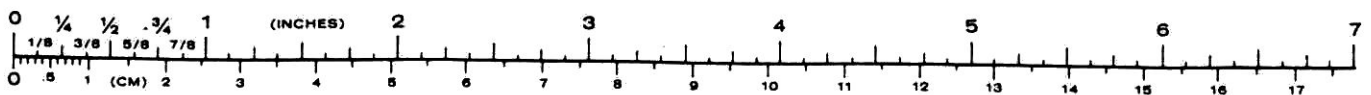

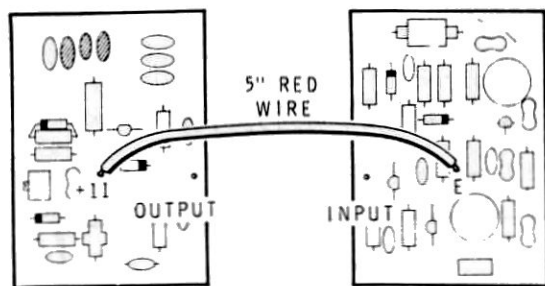

PICTORIAL 1-3

Refer to Pictorial 1-3 for the following steps.

- () Remove the two wire sockets from the foil side of the oscillator circuit board (#85-1205). Clean the solder from both of these holes.
- () Remove the 5/16" bare wires from the foil side of the buffer circuit board (#85-1206). Clean the solder from both of these holes.
- () Position the oscillator and buffer circuit boards as shown.

NOTE: In the following step, you will prepare a wire. To prepare a wire, cut it to the indicated length and remove 1/4" of insulation from each end.

- () Prepare a 5" red wire.
- () Connect one end of the 5" red wire to the oscillator circuit board hole +11. Solder the wire to the foil.
- () Connect the other end of the 5" red wire to the buffer circuit board hole E. Solder the wire to the foil.
- () Refer to Detail 1-3A and press the top edges of ceramic capacitors C1202, C1203, C1204, and C1216 together.
- () Remove the cap from the tube of cement (#350-12) and, using a suitable small pointed tool, punch a hole in the end of the tube nozzle. CAUTION: This cement is very soft and sticky; handle it with care.
- () Squeeze a sufficient amount of cement on the top edges of the two groups of disc capacitors to cement the capacitors together. Take care not to move these capacitors during the following steps as it will require several hours for the cement to set.

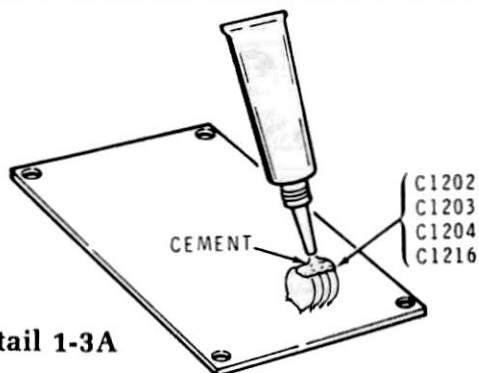

Detail 1-3A

- () Refer to your SB-104A Assembly Manual, Page 1-29, and reassemble the VFO. Do not install the VFO shield at this time.

Refer to Pictorial 1-4 for the following steps.

- () Cut a 3/4" red wire and remove all of the insulation.
- () Install the 3/4" bare wire between the INPUT hole on the buffer circuit board and the OUTPUT hole on the oscillator circuit board. Solder both of these connections to the foil and remove the excess wire lengths from the component side of the circuit boards. Route the 5" red wire as shown.
- () Refer to your SB-104A Assembly Manual, Page 1-30, and install the VFO shield as shown.
- () Refer to your SB-104A Assembly Manual and reinstall the VFO in your unit.

This completes the "VFO Oscillator Circuit Board" modifications. Proceed to the "Transmitter Audio/Reg Circuit Board."

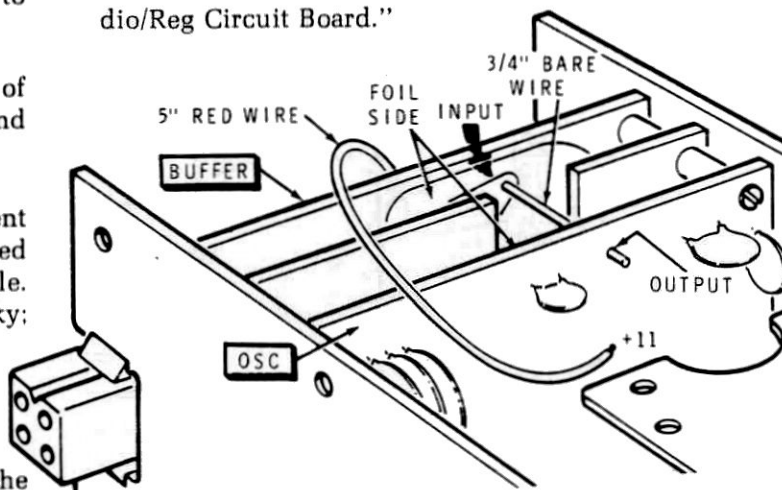

PICTORIAL 1-4

TRANSMITTER AUDIO /REG CIRCUIT BOARD

START →

() Remove the transmitter audio/reg circuit board (B) from the unit and position it as shown. Then perform the following steps.

() R254: 750 Ω, 5% (violet-green-brown-gold).

NOTE: When you install the following tantalum electrolytic capacitor, be sure to position the plus (+) marked or dot (•) marked lead in the plus (+) marked hole.

POSITIVE MARKING (+)

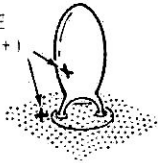

() C227: 47 μF tantalum.

() C222: .1 μF Mylar.

() C208: .1 μF Mylar.

() R209: 33 kΩ (orange-orange-orange).

() R207: 1.5 MΩ (brown-green-green).

() Q210: MPS652 transistor (#417-134).

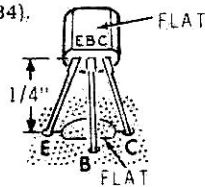

() Solder the leads to the foil and cut off the excess lead lengths.

() Reinstall the circuit board in the unit.

FINISH

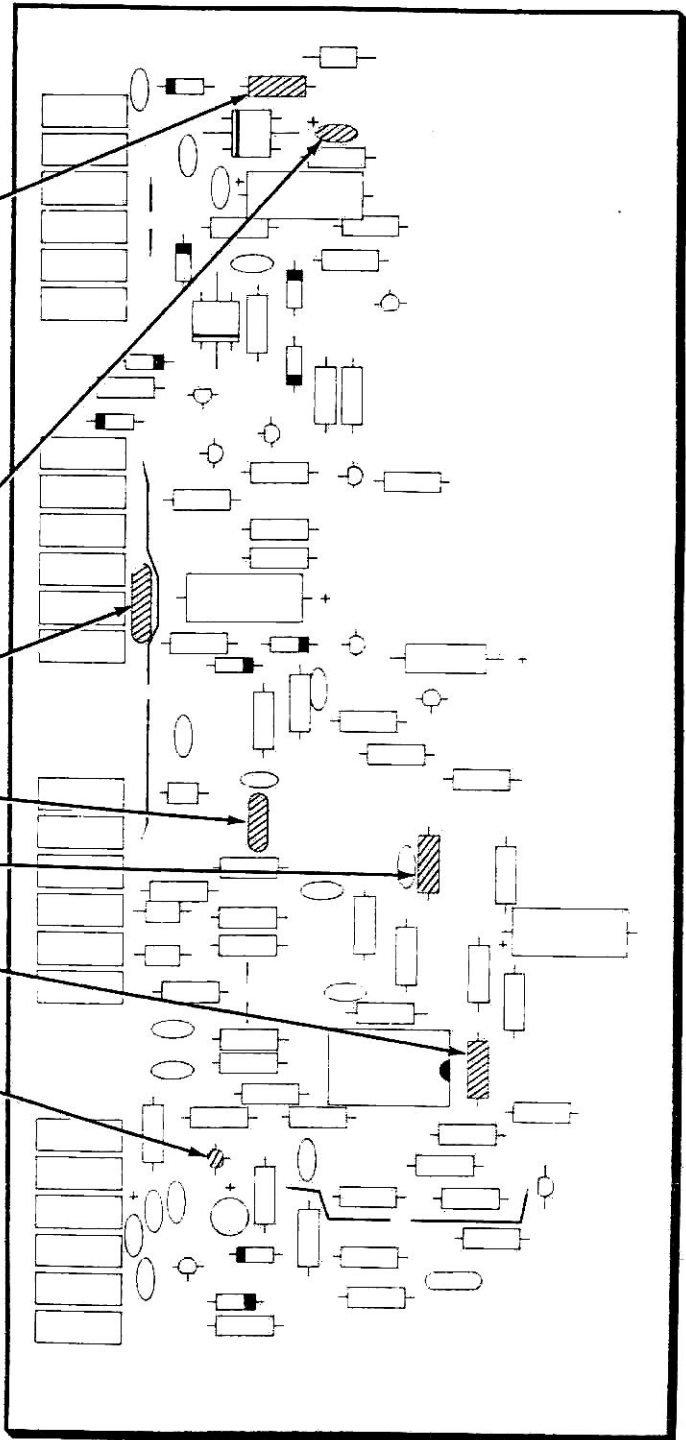

PICTORIAL 2-1

START 

() Remove the transmitter IF circuit board (C) from the unit and position it as shown. Then perform the following steps.

() Form the leads of a 390 Ω, 1/4-watt (orange-white-brown) resistor as shown. Then cut each lead of a 39 pF capacitor to 1/2" and wrap the capacitor leads around the resistor leads. Solder the leads together as shown.

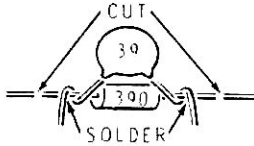

() R314, C373: 390 Ω/39 pF resistor-capacitor assembly.

() R332: 1210 Ω, 1%, 1/8-watt.

() Q303: 2N5089 transistor (#417-244).

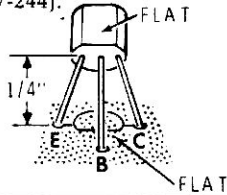

() R328: 6110 Ω, 1%, 1/8-watt.

() R329: 12 kΩ, 1/4-watt (brown-red-orange).

() C322: Remove and discard.

() C369: 390 pF mica.

() R321: 3300 Ω (orange-orange-red).

() R322: 6800 Ω, 5%, 1/4-watt (blue-gray-red).

() Q302: 2N5089 transistor (#417-244).

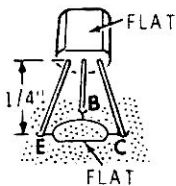

() C361: 15 pF mica.

() C358: 15 pF mica.

() Solder the leads to the foil and cut off the excess lead lengths.

TRANSMITTER IF CIRCUIT BOARD

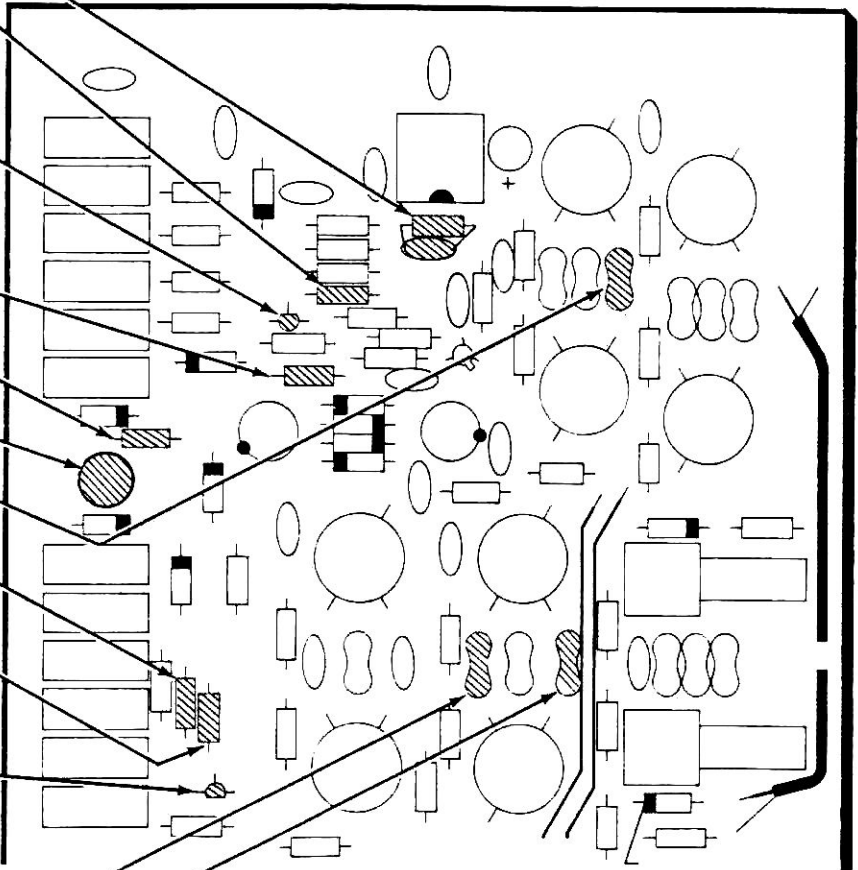

PICTORIAL 3-1

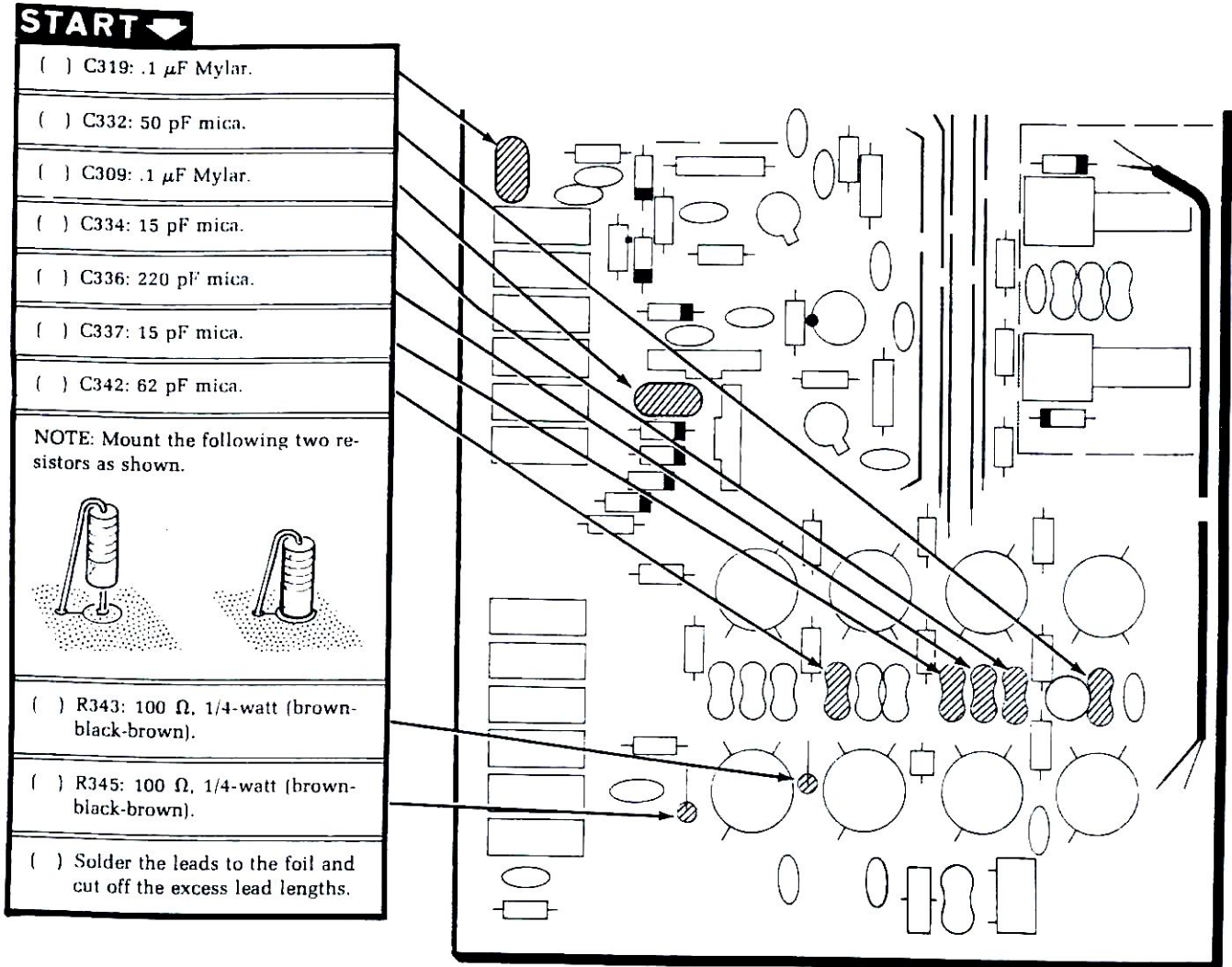

PICTORIAL 3-2

Refer to Pictorial 3-3 for the following step.

- () Solder the spring clip to the shield in the area shown. (This clip will ground the shield directly to the compartment shield when the circuit board is installed.)

PICTORIAL 3-3

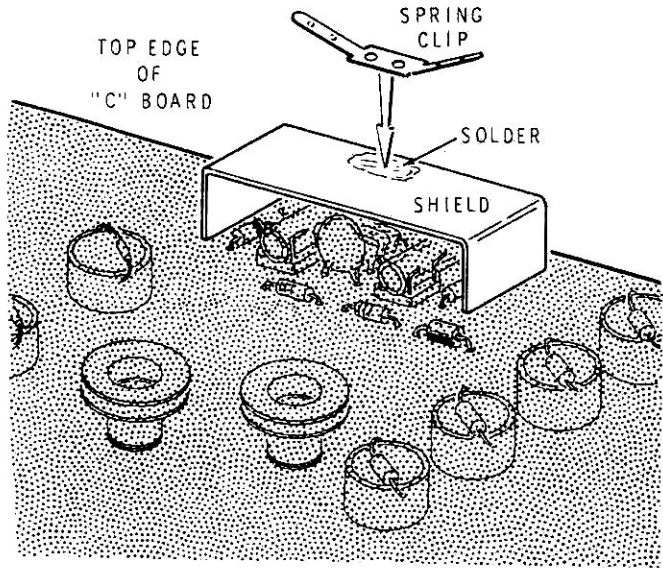

START →

Refer to Pictorial 3-4A for the following steps.

- () Remove and discard coil L321, the 470 pF mica capacitor, and the 6 pF ceramic capacitor.

- () Cut off the indicated lugs from the 15-60 pF trimmer capacitor.

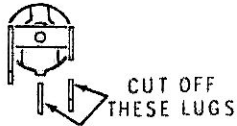

- () Cut a 1/2" length of brown wire and remove all of the insulation.

- () Solder one end of the 1/2" bare wire at the indicated location on the 15-60 pF trimmer capacitor.

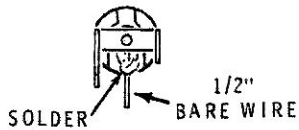

Refer to Pictorial 3-4B for the following steps.

- () L321: 13.2 μ H toroid coil (#40-1877) at 470. Turn the coil as shown.



- () C348: 140 pF mica.

- () C349: Install the prepared trimmer capacitor. Carefully form the 1/2" bare wire as shown. Position the trimmer as shown.

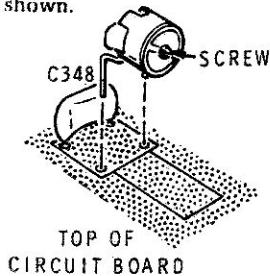

- () C333: Install the 3.5-18 pF trimmer capacitor.

- () Solder the leads to the foil and cut off the excess lead lengths.

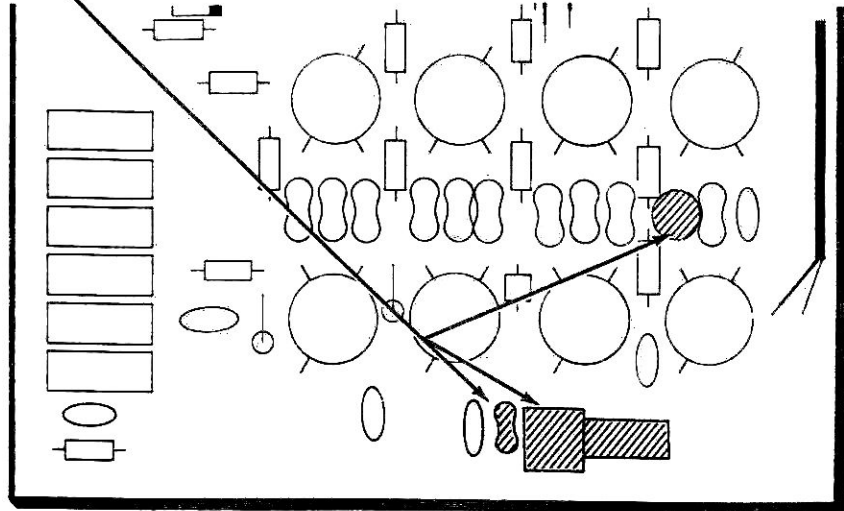

PICTORIAL 3-4A

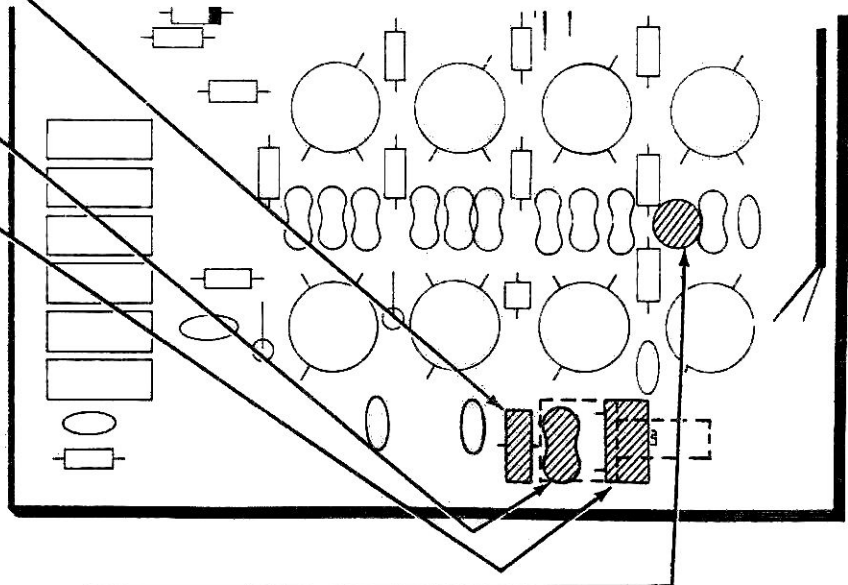

PICTORIAL 3-4B

START ↘

- () Position the circuit board with the foil side up as shown.
- () Use a penknife or a single-edged razor blade and cut the circuit board foil at the indicated location. Cut the foil **below** the indicated hole.
- () Reinstall the circuit board in your unit.

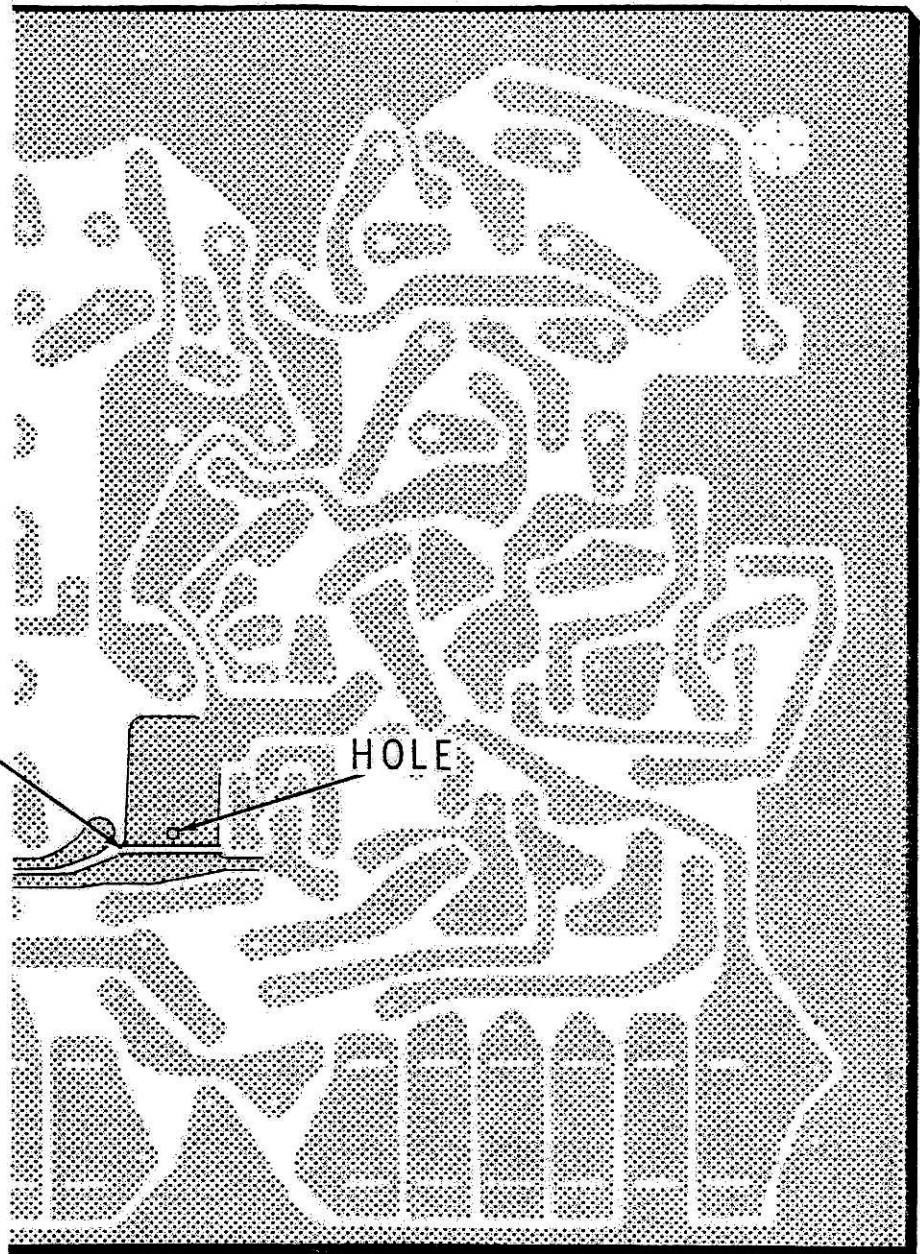
FINISH

PICTORIAL 3-5

HFO/PREMIER CIRCUI BOARD

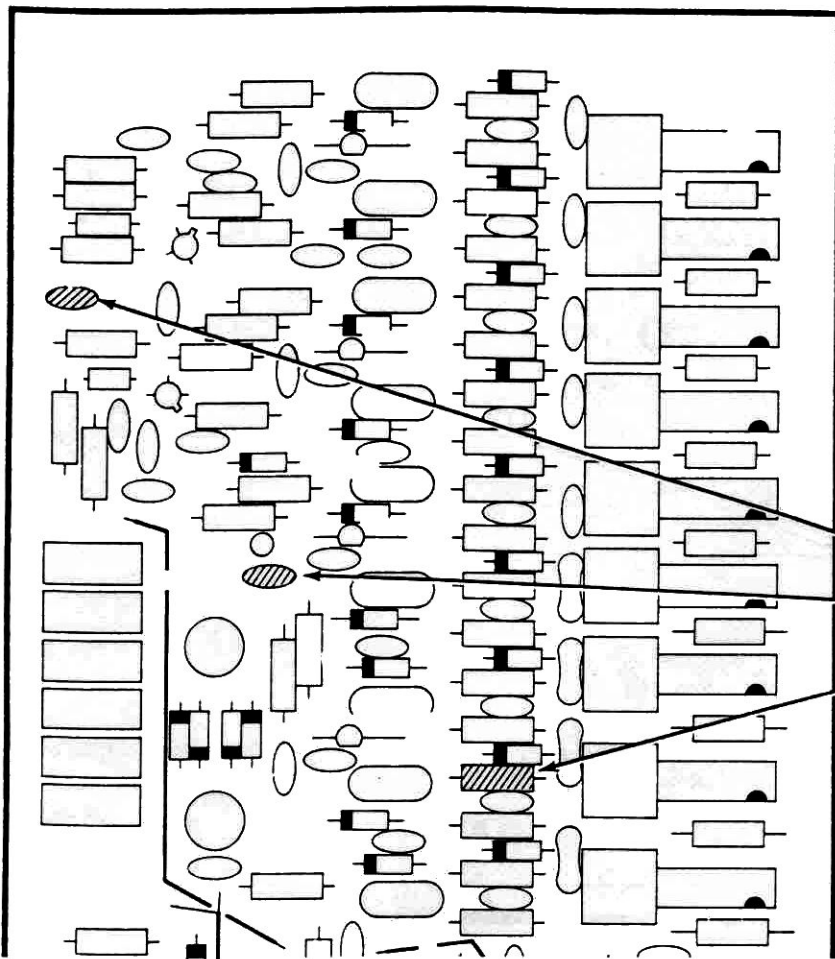

START ↓

() Position the HFO/PREMIER circuit board (D) as shown. Perform the following steps.

NOTE: When you install disc capacitors, do not push the insulated portions of the leads into the circuit board holes. This could make it difficult to solder the leads to the foil.

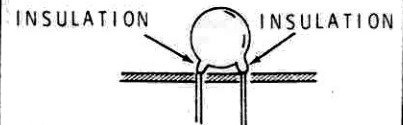

() C441: 33 pF ceramic.

() C414: 18 pF ceramic.

() R407: 15 kΩ (brown-green-orange).

() Solder the leads to the foil and cut off the excess lead lengths.

() Reinstall the "D" circuit board in the unit.

FINISH

PICTORIAL 4-1

CARRIER GENERATOR/XTAL FILTER CIRCUIT BOARD

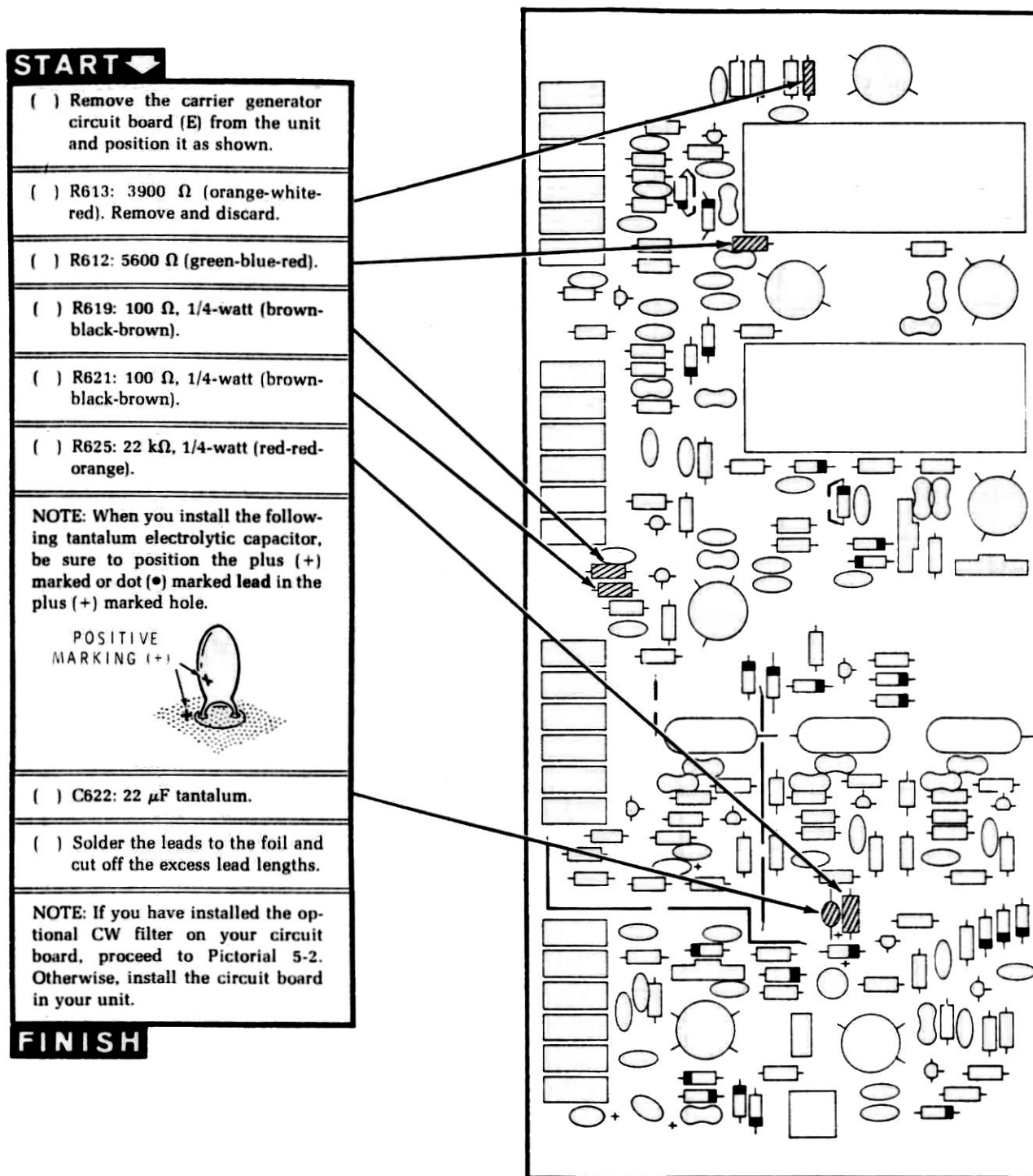

PICTORIAL 5-1

START →

NOTE: If you have the optional CW filter installed, perform the following steps.

- () R679: 5600 Ω (green-blue-red).
- () R677: 5600 Ω (green-blue-red).
- () R684: 1000 Ω (brown-black-red).
- () Install the circuit board in your unit.

FINISH

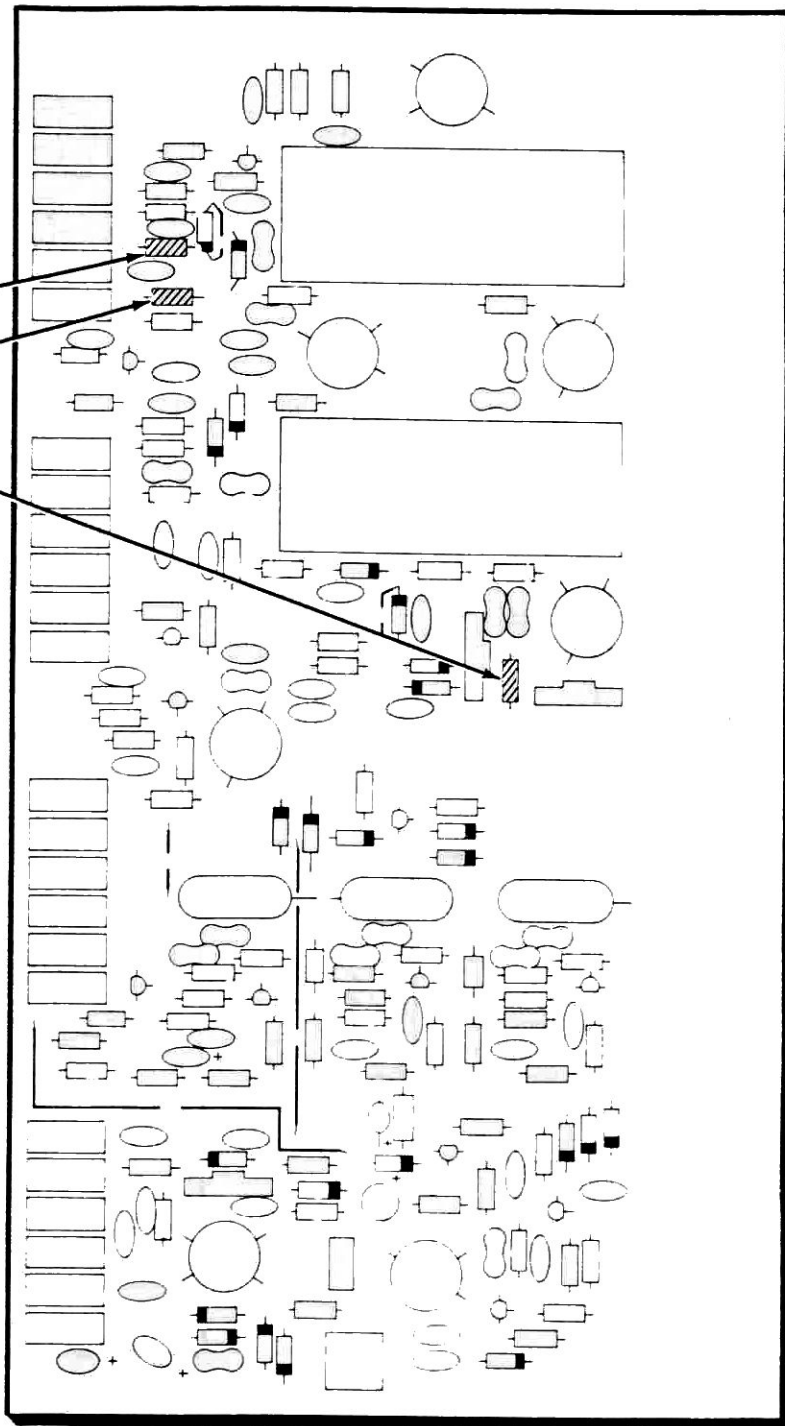

PICTORIAL 5-2

RECEIVER IF/AUDIO CIRCUIT BOARD

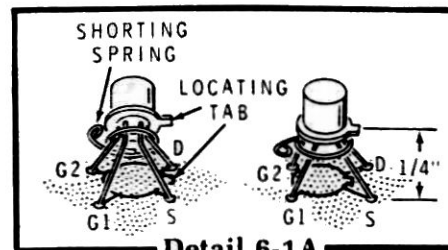

START

() Remove the receiver IF/audio circuit board (F) from the unit and position it as shown.

() Q501: 40673 transistor (#417-274). First line up the tab with the tab outline on the circuit board. Insert the transistor leads (see Detail 6-1A) into the correct holes on the circuit board. Solder each lead to the foil and cut off the excess lead lengths. Then remove the shorting wire from the transistor leads.

() Form the leads of a 15 kΩ (brown-green-orange) resistor as shown. Then cut each lead of a .01 μF ceramic capacitor to 1/2" and wrap the capacitor leads around the resistor leads. Solder the leads together as shown.



() R507, C553: 15 kΩ/.01 μF resistor-capacitor assembly.

() C543: 820 pF mica.

() R566: 180 kΩ (brown-gray-yellow).

() R564: 330 kΩ (orange-orange-yellow).

() R567: 180 kΩ (brown-gray-yellow).

() R568: 100 kΩ (brown-black-yellow).

() R569: 330 kΩ (orange-orange-yellow). Remove and discard.

() R532: .82 Ω, 5%, 2-watt (gray-red-silver-gold).

() Solder the leads to the foil and cut off the excess lead lengths.

() Reinstall the circuit board in the unit.

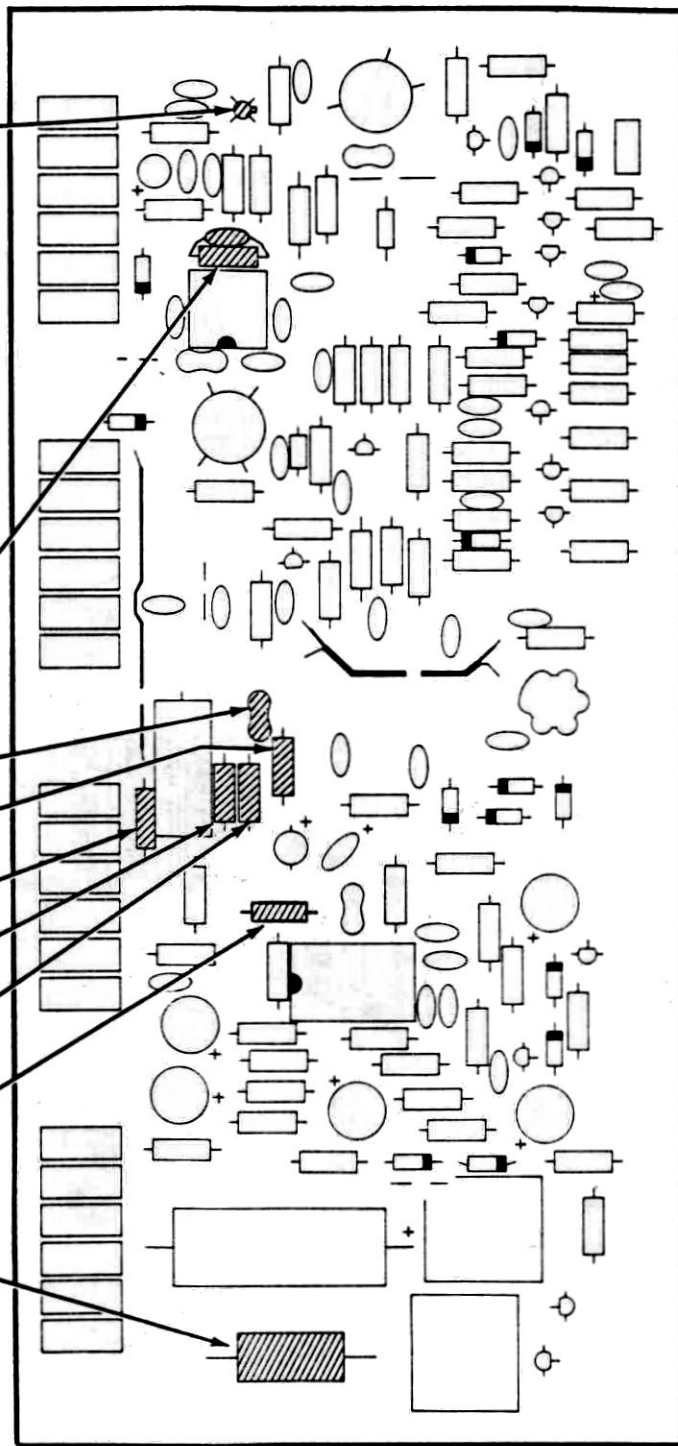

FINISH

PICTORIAL 6-1

POWER AMPLIFIER CIRCUIT BOARD

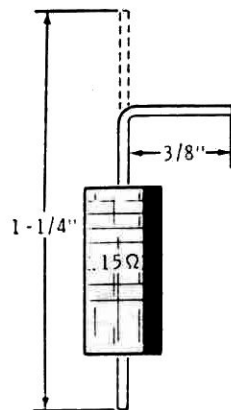

Detail 7-1A

Refer to Pictorial 7-1 for the following steps.

- () Remove the power amplifier circuit board from your unit and remove the heat sink. Set the heat sink aside. Be careful not to get any of the thermal compound on your clothing, since it is difficult to remove.

- () Position the circuit board as shown.

NOTE: Depending on which PA circuit board is in your unit, you will have either wires and ferrite beads or $.51 \Omega$ resistors installed at holes A and B.

- () Remove each wire and ferrite bead, or both $.51 \Omega$ (green-brown-gold-gold) resistors, from the circuit board at holes A and B. Discard the wires and ferrite beads, or resistors.
- () Refer to Detail 7-1A and prepare two $.15 \Omega$, 5%, 2-watt (brown-green-silver-gold) resistors as shown.

- () Install one prepared resistor on the circuit board at hole A and the other prepared resistor at hole B. Solder each resistor at the indicated locations and cut off the excess lead lengths from the foil side of the circuit board.

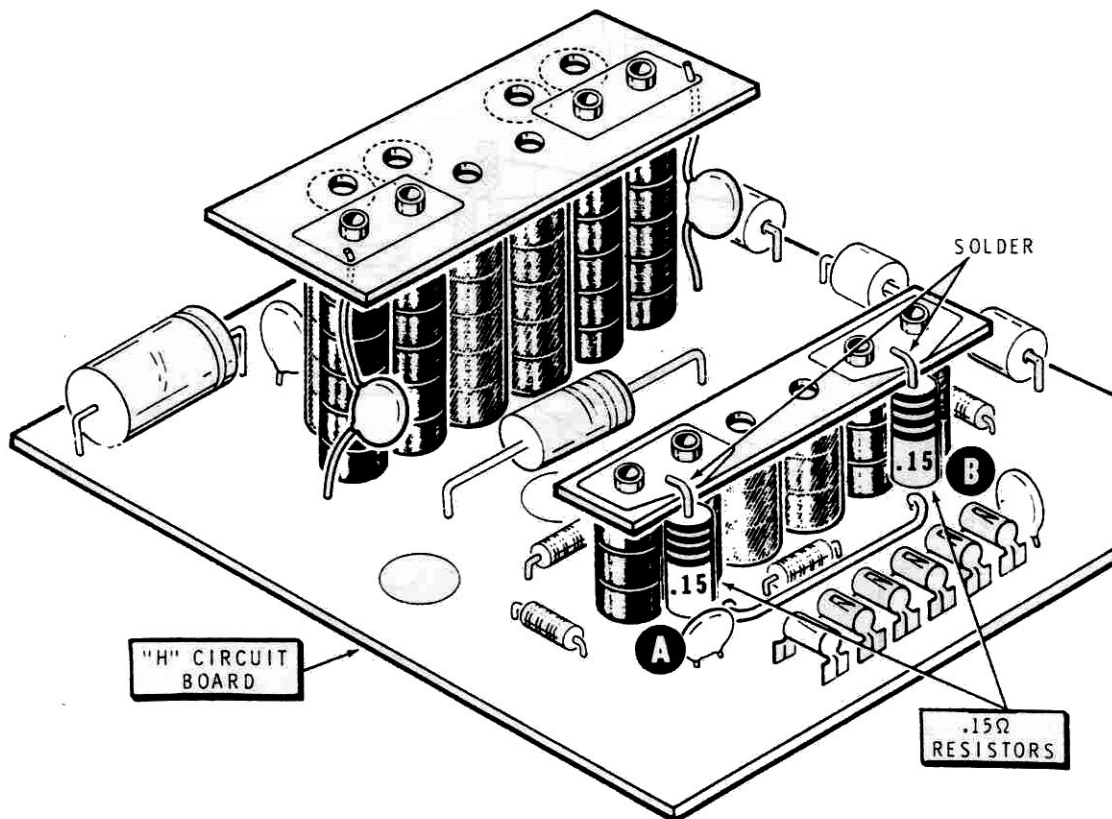

PICTORIAL 7-1

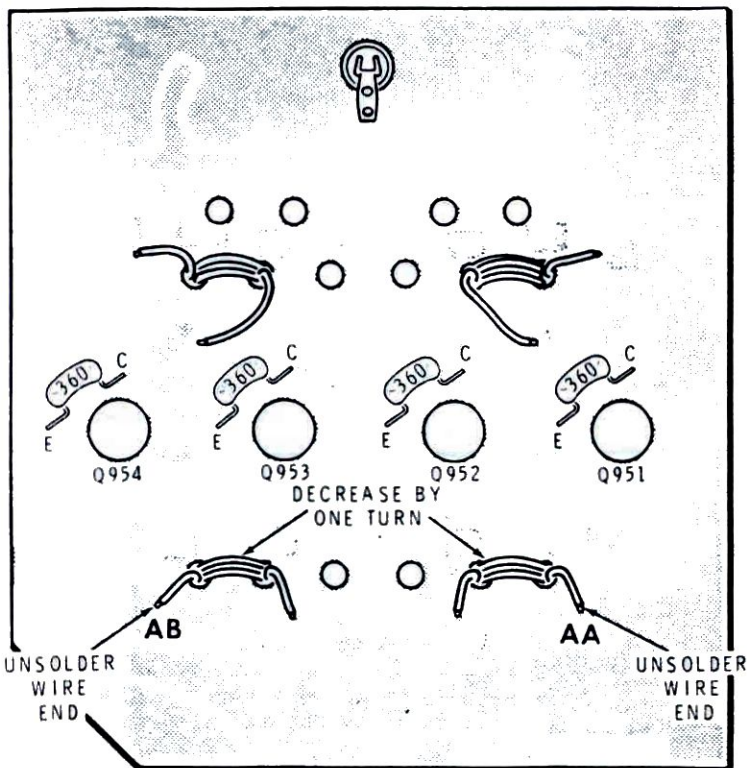

PICTORIAL 8-1

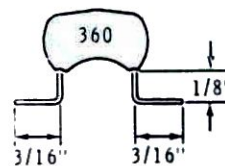

Detail 8-1A

Refer to Pictorial 8-1 for the following steps.

- () Turn the power amplifier circuit board over (foil side up) and unsolder the wire at hole AA.
- () Decrease the turns of wire, through the two brass tubes, by one turn (five to four).
- () Route the wire back to hole AA and cut off the excess wire length at that point. Discard the excess wire.
- () Prepare the free end of the wire and apply a small amount of solder to the wire strands to hold them together. Solder the wire to hole AA.

- () Unsolder the wire at hole AB and repeat the three previous steps.
- () Refer to Detail 8-1A and prepare the leads of the four 360 pF mica capacitors as shown.
- () C966, C967, C968, C969: Solder the leads of each prepared 360 pF mica capacitor from the collector (C) to the emitter (E) of transistors Q951, Q952, Q953, and Q954. Keep these capacitors tight against the circuit board.
- () Reinstall the heat sink on the circuit board.
- () Install the circuit board in your unit.



DRIVER CIRCUIT BOARD

START	
<input type="checkbox"/> Remove the driver circuit board (j) from your unit.	
<input type="checkbox"/> Remove the heat sink from the circuit board.	
<input type="checkbox"/> R904: 470 Ω, 1-watt (yellow-violet-brown).	
<input type="checkbox"/> C909: .001 μF ceramic.	
<input type="checkbox"/> R903: If your driver transistors are type TRW6619, install a 220 Ω, 2-watt (red-red-brown) resistor at R903. If the transistors are type CTC, disregard this step. You should have a 140 Ω, 5-watt resistor installed at R903.	
<input type="checkbox"/> C906: .1 μF Mylar.	
<input type="checkbox"/> Solder the leads to the foil and cut off the excess lead lengths.	
<input type="checkbox"/> Position the circuit board with the foil side facing up and scrape the solder resist from around the three mounting holes. Apply a small amount of solder to the bare foil.	
<input type="checkbox"/> Reinstall the heat sink on the circuit board.	
<input type="checkbox"/> Reinstall the circuit board in the unit.	

PICTORIAL 9-1

ALC/OUTPUT CIRCUIT BOARD

START

- () Remove the ALC/output circuit board (K) from your unit and position it as shown.
- () Cut the wire from the top wafer switch SW1C between lugs 12 and 14.
- () Cut a 3/8" length of gray wire and remove the insulation.
- () Refer to Detail 10-1A and solder the 3/8" bare wire between wafer SW1C lug 14 (S-1) and wafer SW1D lug 14 (S-1).
- () C802: 105 pF mica.
- () C801: 130 pF mica.
- () L814: .82 μ H peaking coil (#40-1713). NOTE: Your unit may already have this component installed. If not, install it in the holes provided below S1.
- () L803: Remove coil L803 and save it.
- () L803: .44 μ H (#40-1865) coil.
- () C804: 105 pF mica.
- () C811: 150 pF mica.
- () Solder the leads to the foil and cut off the excess lead lengths.
- () L804: Remove and discard coil L804. Install the coil which you removed from L803 at L804.

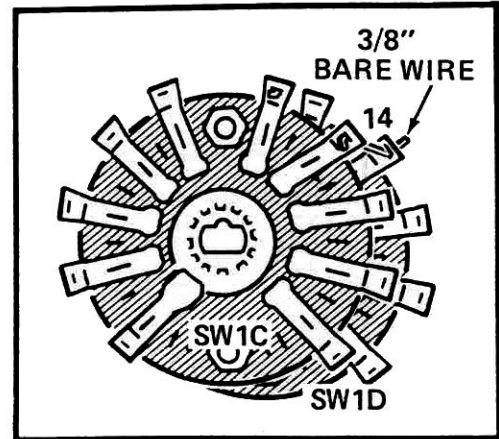

DETAIL 10-1A

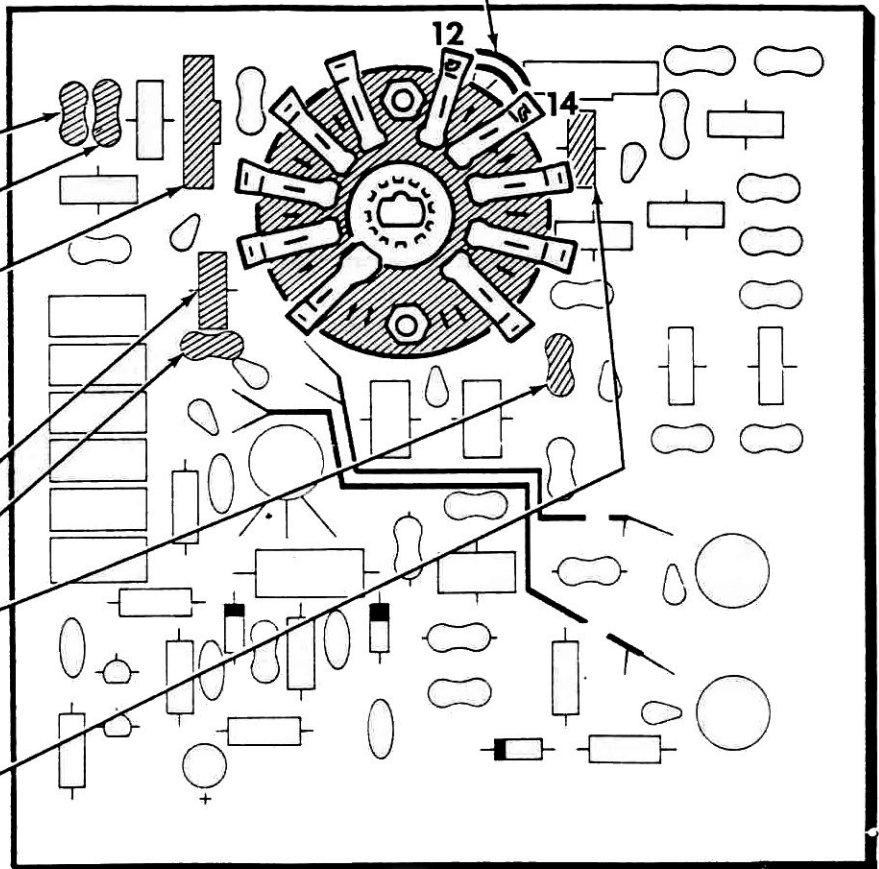

PICTORIAL 10-1

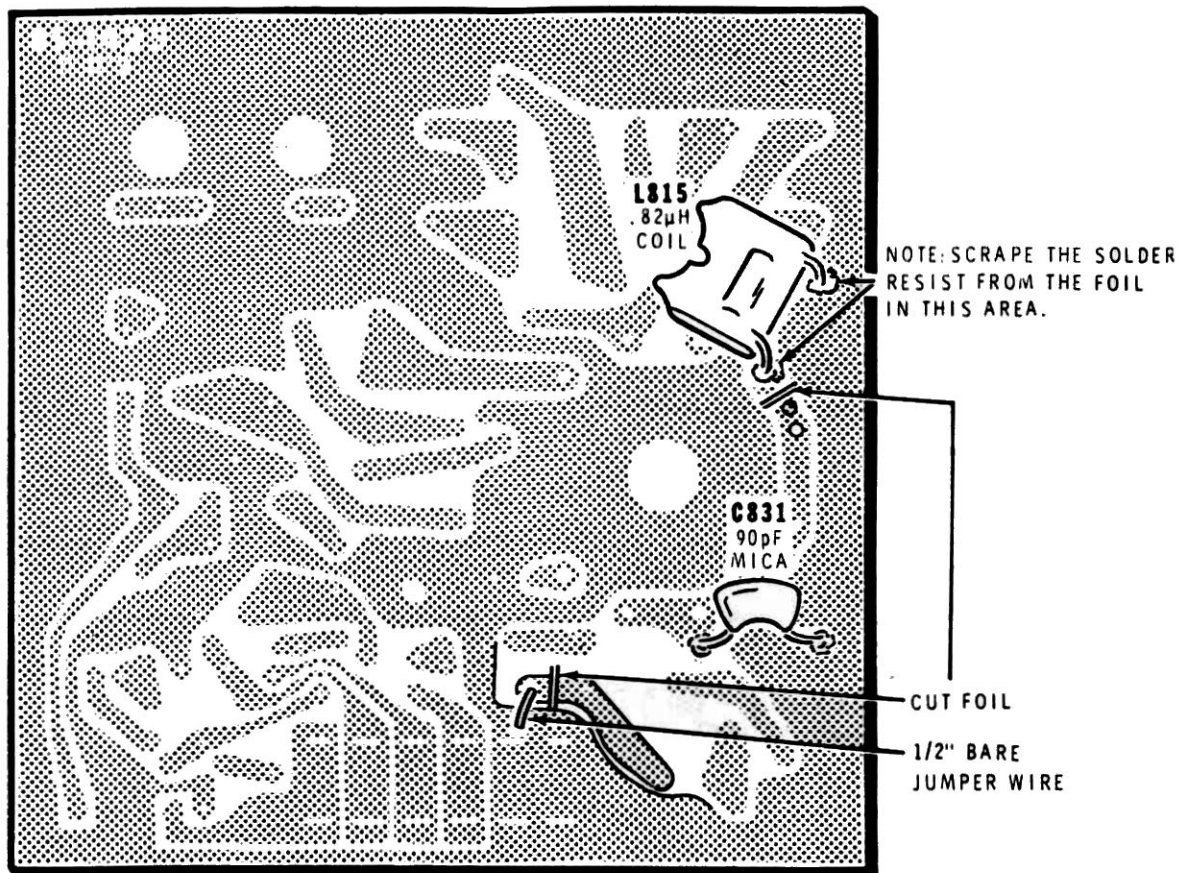

PICTORIAL 10-2

Refer to Pictorial 10-2 for the following steps.

- () Position the circuit board as shown.
- () Use a sharp knife or single-edged razor blade and cut the foil at the two indicated locations.
- () Solder a 1/2" bare jumper wire between the two foils as shown.
- () Cut the leads of the 90 pF mica capacitor to 1/4".
- () C831: Solder the prepared 90 pF mica capacitor across coil L814 from the foil side of the circuit board as shown. Position the capacitor body tight against the circuit board.
- () Cut the leads of the .82 μ H coil to 1/4". Form an "L" in one of the coil leads.
- () L815: Solder the prepared coil L815 to the foil side of the circuit board as shown. Solder the curved coil lead to the ground foil. Keep the lead close to the inside edge of the foil so that it does not interfere with the chassis during installation. Position the coil body tight against the circuit board.
- () Reinstall the circuit board in the unit.

VFO/FILTER CIRCUIT BOARD

START

Position the VFO/filter circuit board (#85-1930-1) as shown and complete the following steps.

NOTE: To prepare a length of wire, cut it to the indicated length and remove 1/4" of insulation from each end.

() Prepare a 1-3/4" gray wire. Remove an extra 1/4" of insulation from either end of the wire. Then insert the 1/4" stripped end in hole D and solder the wire to the foil. The free end of this wire will be connected later.

() L1253: Toroid coil (#40-1869).



() C1254: 1000 pF mica.

() L1252: Toroid coil (#40-1872).

() C1253: 1000 pF mica.

() L1251: Toroid coil (#40-1869).

() R1254: 100 Ω (brown-black-brown).

() R1252: 22 kΩ (red-red-orange).

() C1251: 200 pF ceramic.

() Solder the leads to the foil and cut off the excess lead lengths.

() Squeeze a little cement into the centers of the three toroid coils to affix them to the circuit board.

1/2" STRIPPED END

1-3/4" GRY

1-3/4" RED

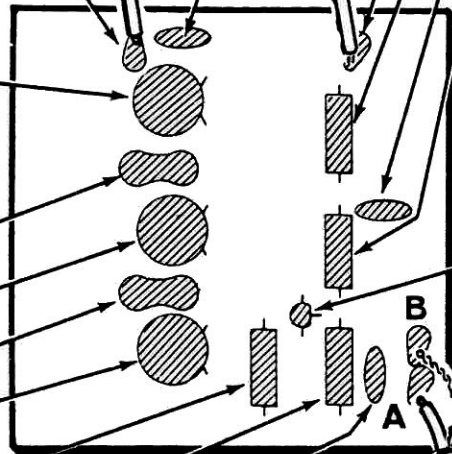

CONTINUE

() C1255: .01 μF ceramic.

() Prepare a 1-3/4" red wire. Then insert one end of this wire in hole C and solder the wire to the foil. The free end of this wire will be connected later.

() R1253: 100 Ω (brown-black-brown).

() C1252: .01 μF ceramic.

() R1251: 22 kΩ (red-red-orange).

() Solder the leads to the foil and cut off the excess lead lengths.

() Q1251: 2N5770 transistor (#417-293). First line up the flat on the transistor with the outline of the flat on the circuit board. Then insert the transistor leads into their corresponding holes indicated by E, B, and C. Solder the leads to the foil and cut off the excess lead lengths.

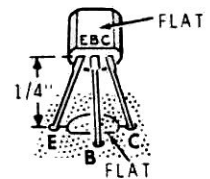

() Prepare a 6" shielded cable. Remove 3/4" of outer insulation and 1/4" of inner insulation from both ends of the cable.

() Connect the inner lead of the 6" shielded cable to hole A and the shield lead to hole B. Solder both leads to the foil and cut off the excess lead lengths. The free end will be connected later.

Proceed to "Installation of the New VFO/Filter Circuit Board."

PICTORIAL 11-1

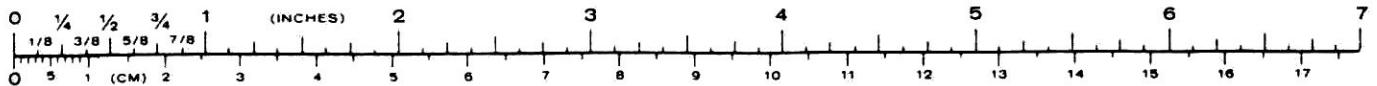



INSTALLATION OF THE NEW VFO/FILTER CIRCUIT BOARDS

Refer to Pictorial 12-1 for the following steps.

- () Position the chassis as shown.
- () Cut the six gray wires on the VFO/filter circuit board at holes C, D, E, F, G, and H.
- () Remove and discard the six gray wires at terminal pins C7, D4, D7, D8, D9, and D10.
- () Remove the two #6 × 5/8" hex-head sheet metal screws and the two 1/8" spacers from the circuit board at AK and AM. Set the hardware aside temporarily.
- () Unsolder the shielded cable wires from terminal pins G3 and G4.
- () Discard the old VFO/filter circuit board.

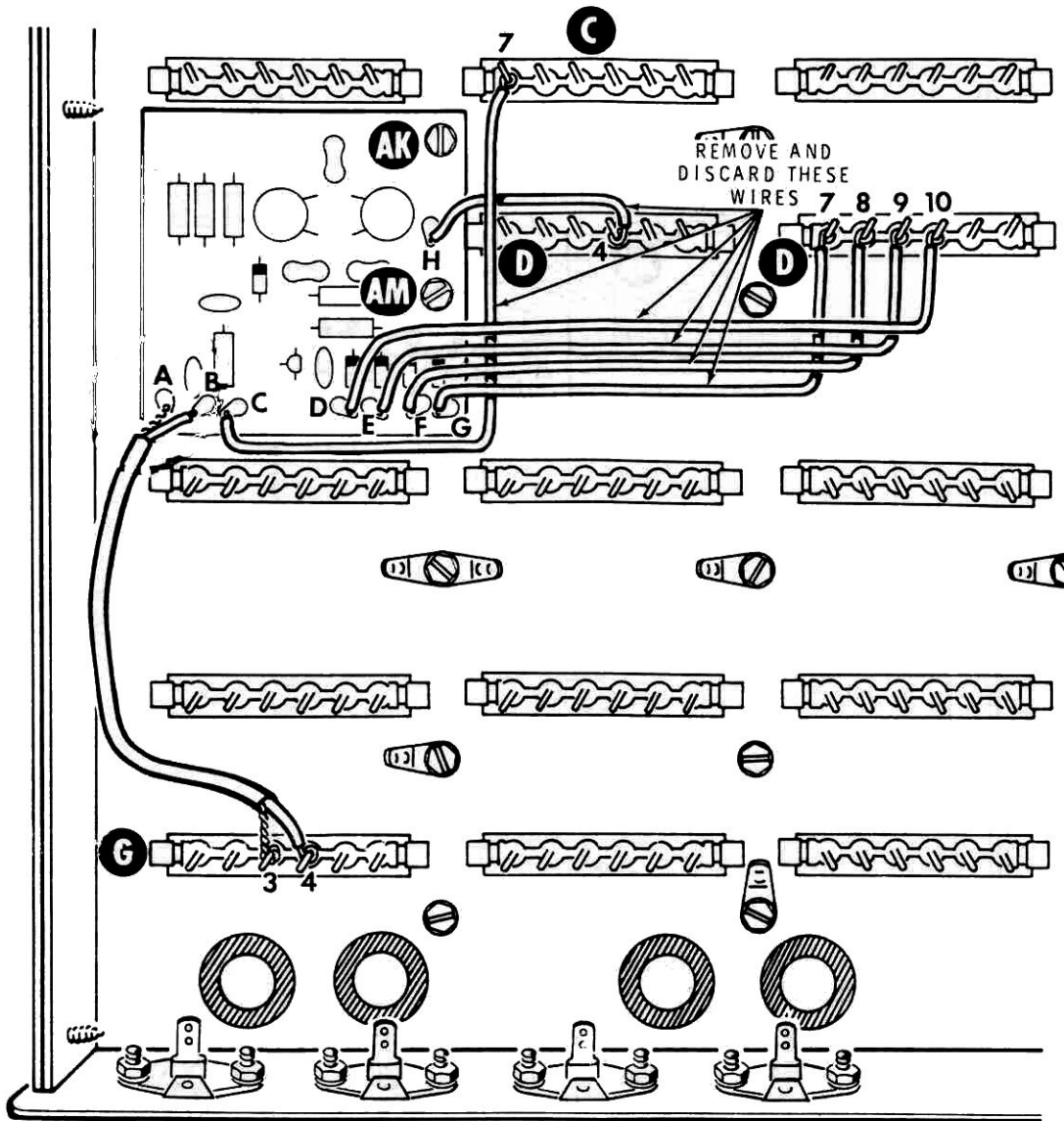

PICTORIAL 12-1

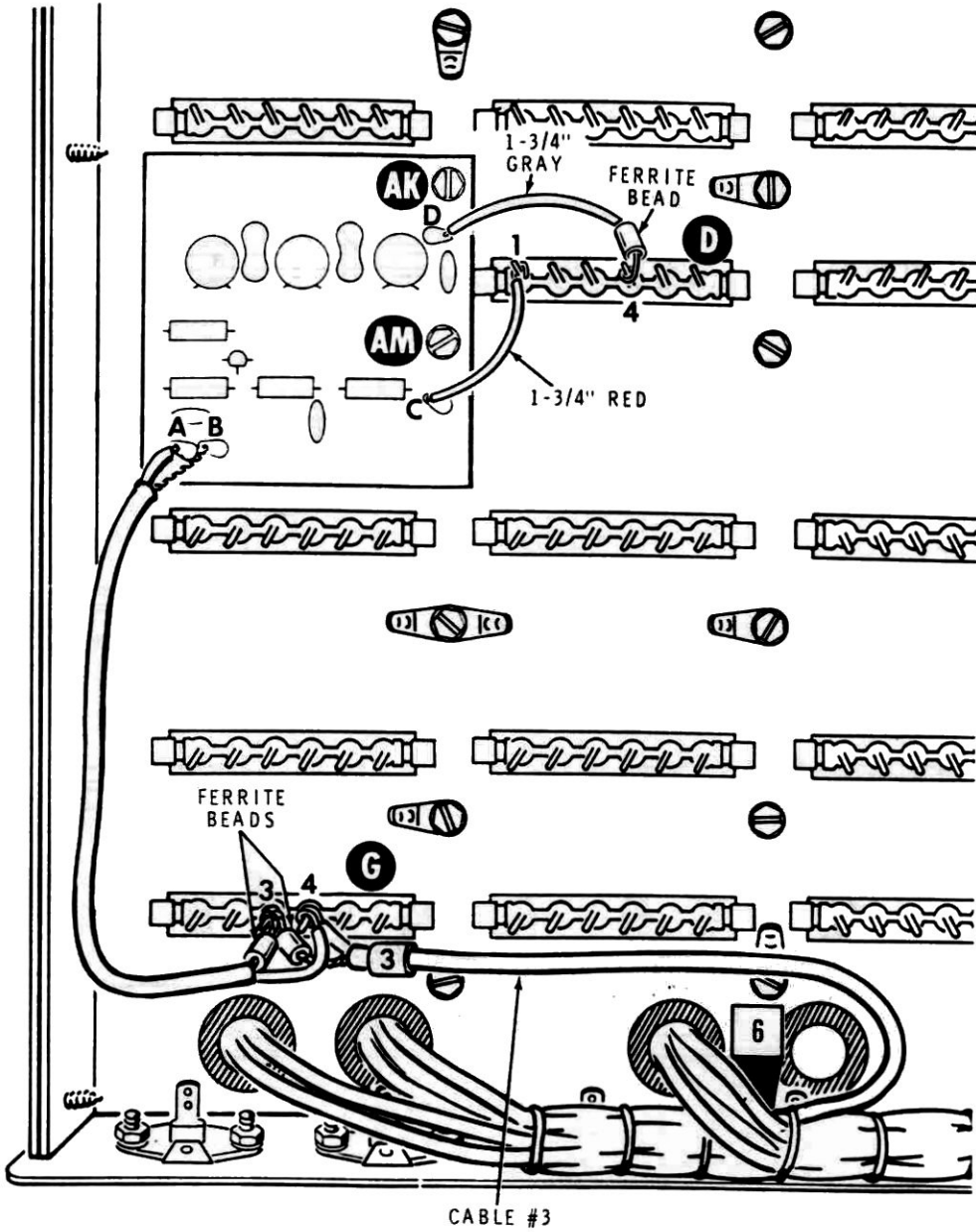

PICTORIAL 13-1

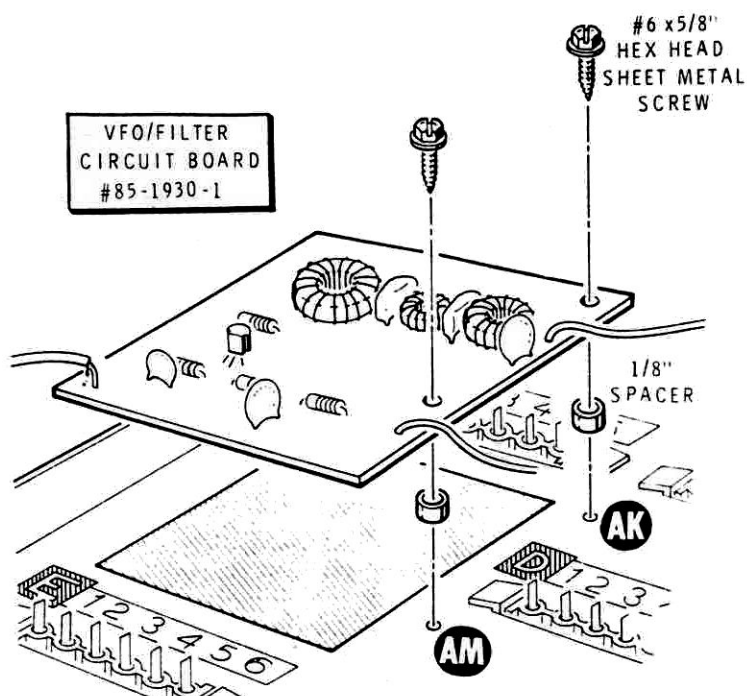

Detail 13-1A

Refer to Pictorial 13-1 for the following steps.

- () Refer to Detail 13-1A and install the new circuit board on the chassis. Use the two hex-head sheet metal screws and the two 1/8" spacers that you previously removed at AK and AM.
- () Connect the free end of the 1-3/4" red wire coming from circuit board hole C to terminal pin D1 (S-3).
- () Install a small ferrite bead on the free end of the 1-3/4" gray wire coming from circuit board hole D. Connect the wire with the ferrite bead to terminal pin D4 (S-1).
- () Disconnect the shield wire on shielded cable #3 at terminal pin G3 and install a small ferrite bead on the shield. Reconnect the shield to terminal pin G3 (NS). NOTE: It may be necessary to remove an extra 1/4" of outer insulation from the shielded cable to make the shield longer.
- () Connect the inner lead of the shielded cable coming from the VFO/filter circuit board to terminal pin G4 (S-3). Then install a ferrite bead on the shield lead and connect the lead to terminal pin G3 (S-4). Dress shielded cable #3 as shown.

This completes the "Installation of the New VFO/Filter Circuit Board." Proceed to "Chassis Changes."

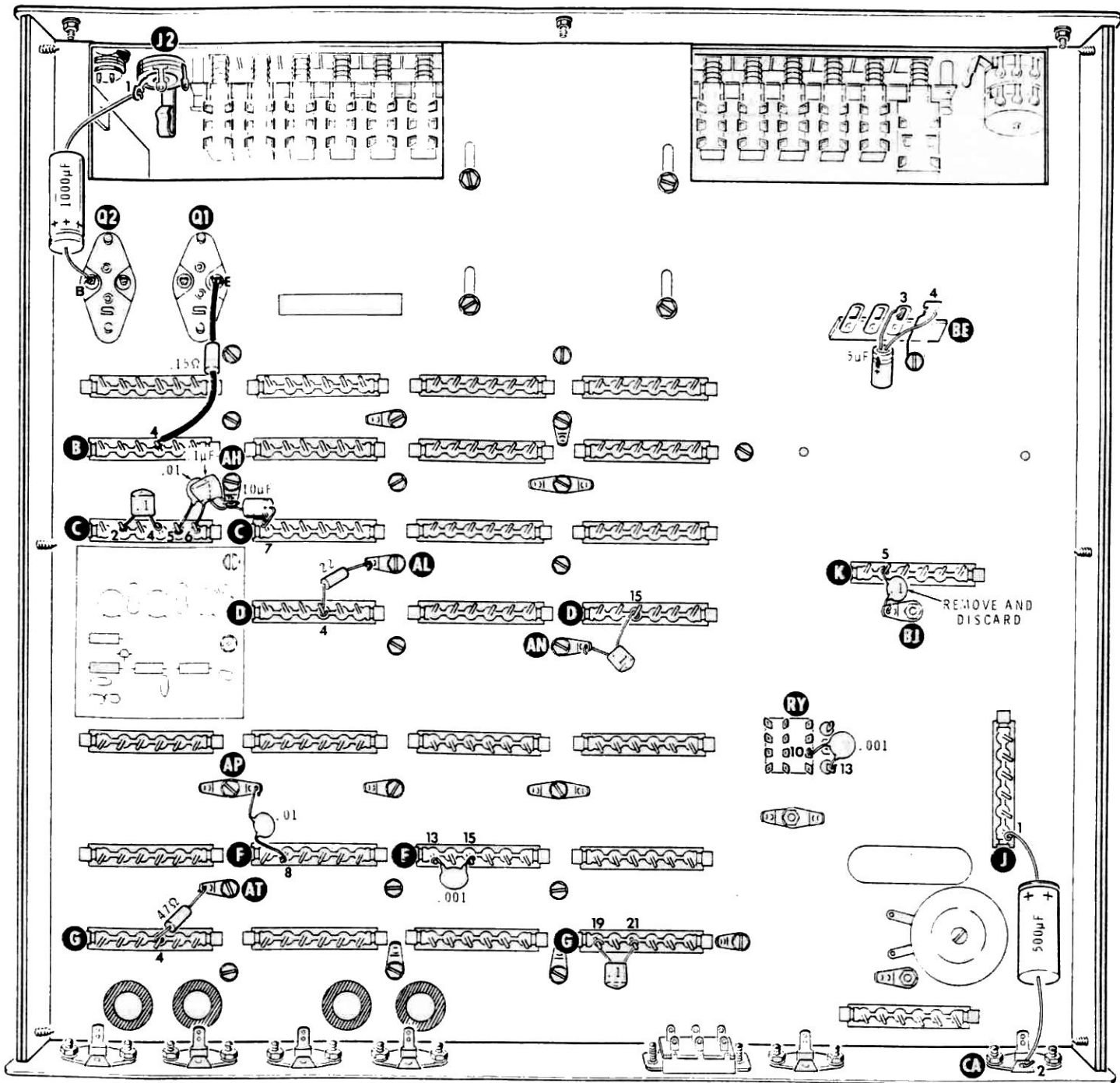

PICTORIAL 14-1

CHASSIS CHANGES

Refer to Pictorial 14-1 for the following steps.

- () Position the chassis as shown.
- () Remove and discard the .33 Ω resistor connected between transistor Q1 and lug E and terminal pin B4. Remove the sleeving from the resistor leads and save it for the next step.
- () Place the 3/4" length of sleeving over one lead of a .15 Ω , 2-watt (brown-green-gold-gold) resistor and the 1" length of sleeving over the other lead.
- () R5: Connect the lead of the .15 Ω resistor with the 3/4" length of sleeving to transistor Q1 lug E (S-1). Connect the other lead to terminal pin B4 (S-3).
- () Connect the positive (+) lead of a 1000 μ F electrolytic capacitor to transistor Q2 lug B (S-2). Connect the other lead to phone jack J2 lug 1 (S-3).
- () C14: Connect the positive (+) lead of a 5 μ F vertical electrolytic capacitor to terminal strip BE lug 3 (S-4). Connect the other lead to lug 4 (S-1).
- () If your unit has a .1 μ F ceramic capacitor installed between terminal pins C2 and C4, remove it.
- () C16: Connect a .1 μ F Mylar capacitor between terminal pins C2 (S-3) and C4 (S-2).
- () C17: Connect a .01 μ F ceramic capacitor between terminal pin C5 (S-2) and solder lug AH (NS).
- () C4: Connect a .1 μ F Mylar capacitor between terminal pin C6 (S-2) and solder lug AH (S-4). Do not allow the lead of this capacitor, that is connected to terminal pin C6, to touch the leads of the .01 μ F ceramic capacitor.
- () C1: Connect the positive (+) lead of a 10 μ F electrolytic capacitor to terminal pin C7 (S-2). Connect the other lead to solder lug AH (S-5).
- () R22: Connect a 22 Ω (red-red-black) resistor between terminal pin D4 (S-2) and solder lug AL (S-3).
- () C19: Connect a .1 μ F Mylar capacitor between terminal pin D15 (S-3) and solder lug AN (S-2).
- () C18: Connect a .01 μ F ceramic capacitor between terminal pin F8 (S-2) and the indicated solder lug at AP (S-2).
- () C13: Connect a .001 μ F ceramic capacitor between terminal pins F13 (S-3) and F15 (S-3).
- () R23: Connect a 47 Ω (yellow-violet-black) resistor between terminal pin G4 (S-3) and solder lug AT (S-5).
- () C21: Connect a .1 μ F Mylar capacitor between terminal pins G19 (S-2) and G21 (S-2).
- () Remove and discard the .1 μ F ceramic capacitor between terminal pin K5 and solder lug BJ.
- () C15: Connect a .001 μ F ceramic capacitor at relay RY between lugs 10 (S-2) and 13 (S-3).
- () C12: Connect the positive (+) lead of a 500 μ F electrolytic capacitor to terminal pin J1 (S-5). Connect the other lead to phono socket CA lug 2 (S-3).

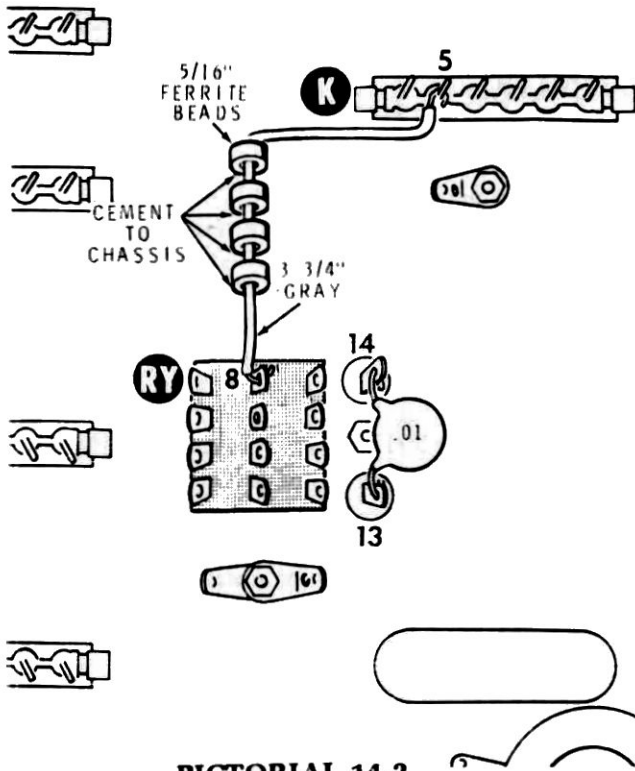

PICTORIAL 14-2

NOTE: In the next step, apply a drop of cement to each ferrite bead. Then, when you install the gray wire, push the beads down against the chassis so the cement will hold them to the chassis.

- () Reconnect the 3-3/4" gray wire with the ferrite beads to terminal pin K5 (S-1).
- () C5: Connect a .01 μF ceramic capacitor at relay RY between lugs 13 (S-3) and 14 (S-2).

Refer to Pictorial 15-1 for the following steps.

- () Prepare a 10" gray wire.
- () Connect one end of the 10" gray wire to terminal pin F7 (S-2), and route the other end through grommet BA.
- () Remove and discard the red wire connected between terminal pins G2 and G13.

Refer to Pictorial 14-2 for the following steps.

- () Unsolder the 3-3/4" gray wire at terminal pin K5 and slide the four large ferrite beads over the wire as shown.

- () Route the heavy orange wire coming from terminal pin B2 to terminal pin G2. Cut the heavy orange wire at the G2 junction and prepare the two wire ends. Make sure you allow enough slack at both ends of the wire before you cut it.

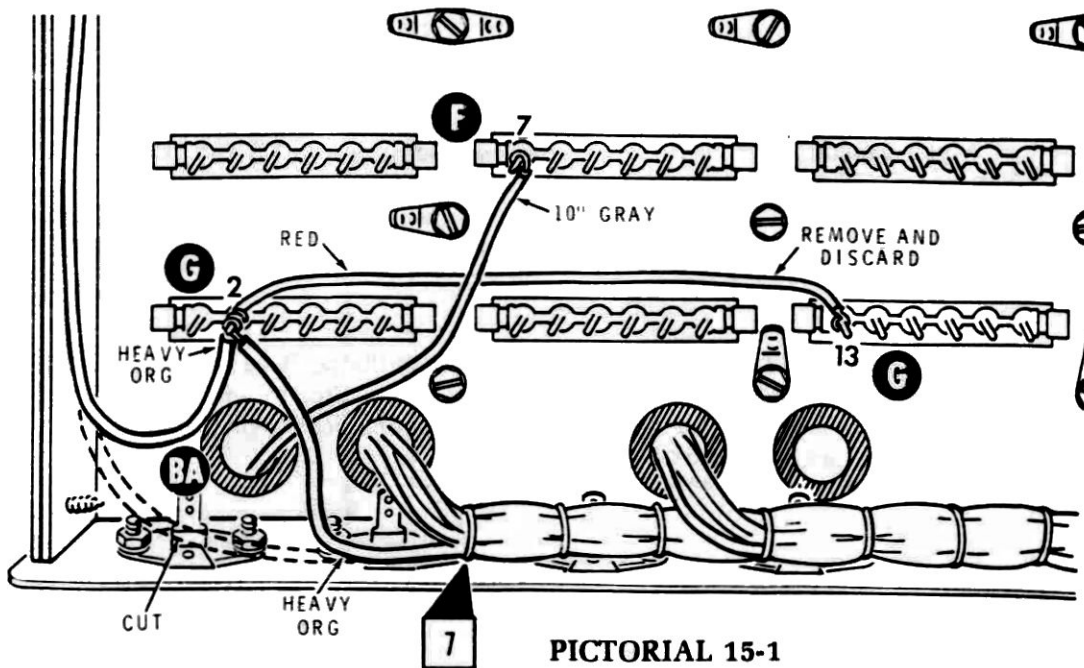

PICTORIAL 15-1

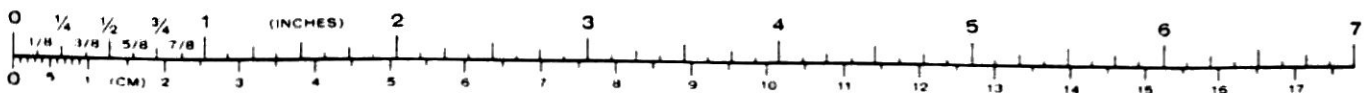

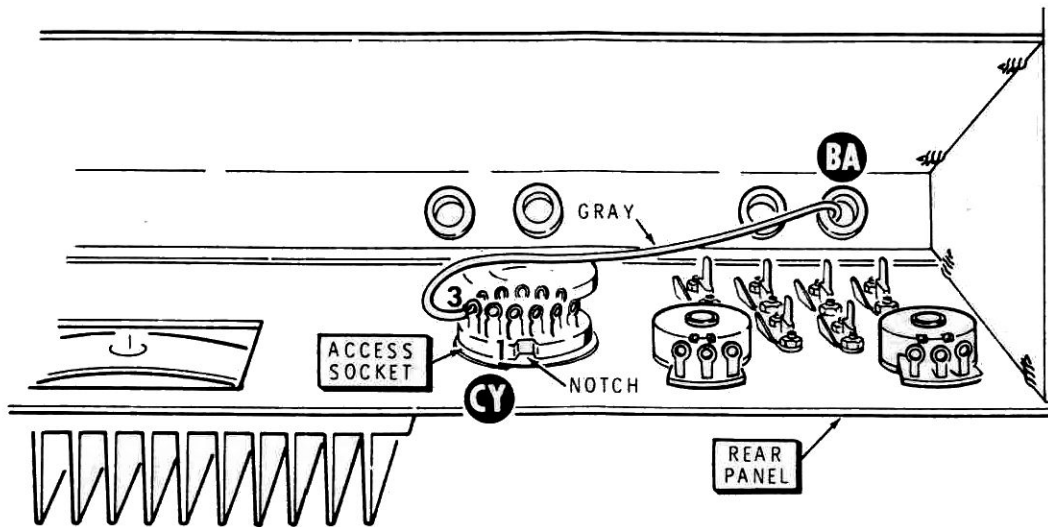

Detail 15-1A

- () Connect both orange wires to terminal pin G2 (S-2).
- () Remove and discard the short gray wire connected to the control ground lug.
- () Refer to Detail 15-1A and position the chassis as shown. Then connect the free end of the 10" gray wire coming from grommet BA to rear panel access socket CY pin 3 (S-1). Be careful not to burn any insulation on the adjacent wires.
- () Prepare the free end of the remaining gray wire (if necessary) and connect it to the control ground lug (S-3).
- () Prepare a 5" gray wire.

Refer to Pictorial 16-1 for the following steps.

- () Cut the two gray wires at control R2 lug 6.
- () Connect one end of the 5" gray wire to terminal strip BE lug 3 (S-3). Connect the other end to control R2 lug 6 (S-1).

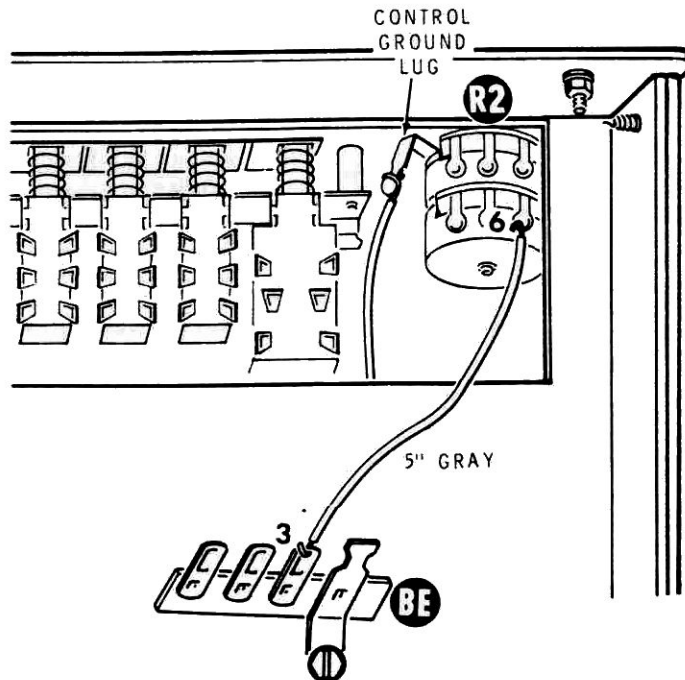

PICTORIAL 16-1

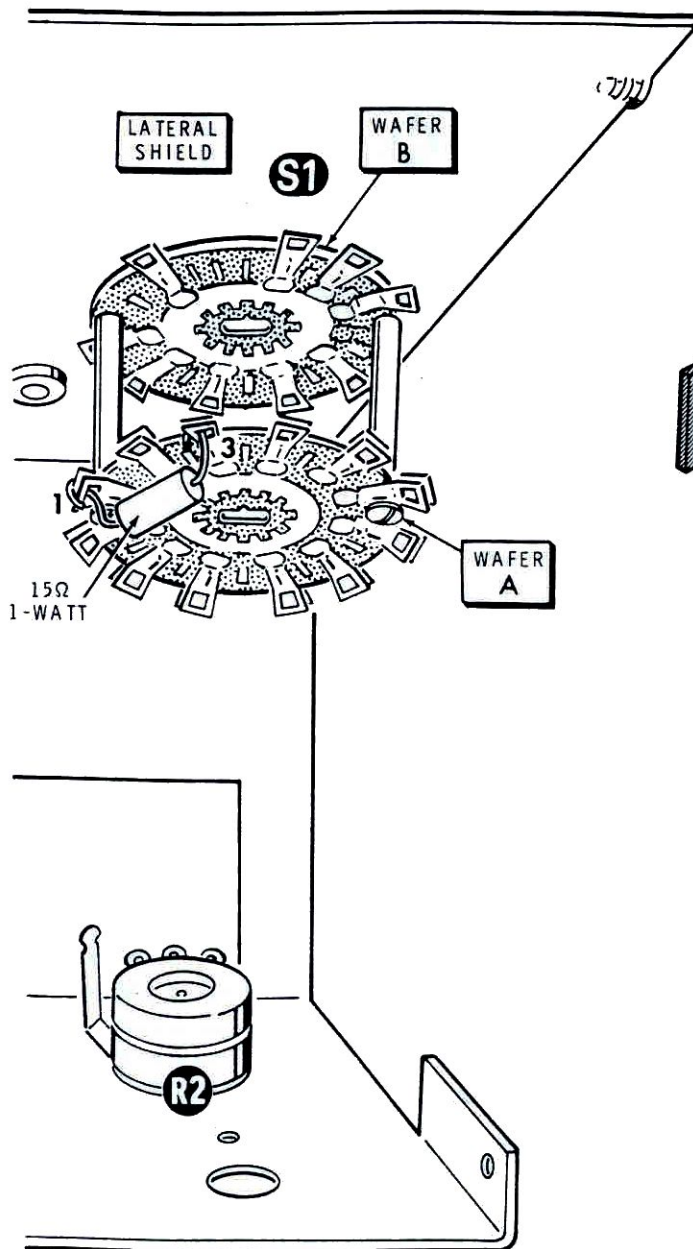

PICTORIAL 16-2

Refer to Pictorial 16-2 for the following steps.

- () Position the chassis as shown.
- () R11: Remove the 15 Ω, 1/2-watt (brown-green-black) resistor from S1 wafer A lugs 1 and 3. Install a 15 Ω, 1-watt resistor in its place.

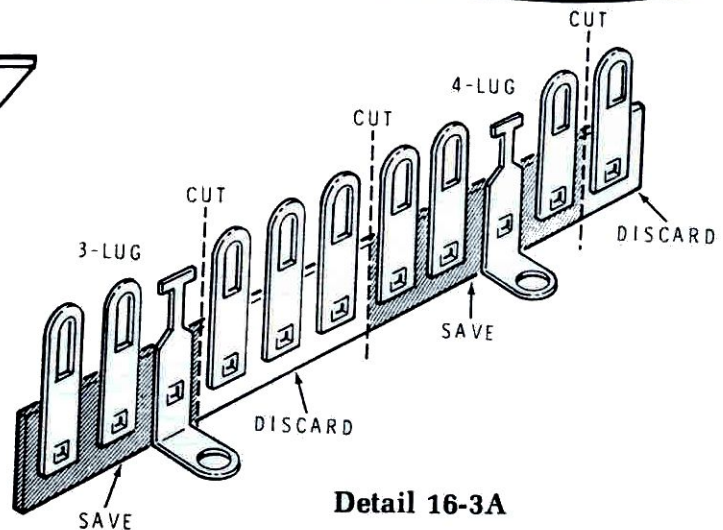

Detail 16-3A

CW CRYSTAL WIDE AND NARROW MODIFICATIONS

Refer to Pictorial 16-3 for the following steps.

NOTE: When you complete the following modifications, the SSB filter will be enabled when the 100 Hz switch is out, and the CW filter will be enabled when the 100 Hz switch is in.

- () Remove and discard the gray jumper wire between terminal pins E9 and E17.
- () Remove the white-orange wire at terminal pin E9 and connect it to terminal pin E17 (S-2).
- () Refer to Detail 16-3A and prepare the 11-lug terminal strip as shown. Use diagonal cutters to cut through the terminal strip insulator. Save the indicated sections.
- () Remove the hex-head screw at chassis hole AM and install the prepared 3-lug terminal strip as shown.
- () Install a 1N4149 diode (#56-56) at terminal strip AM between lugs 2 (NS) and 3 (NS). Connect the banded end at lug 3.
- () Cut a 1-5/8" gray wire and remove all the insulation.
- () Connect the 1-5/8" gray wire between terminal strip AM lug 3 (S-2) and terminal pin E10 (S-2).
- () Remove the white-black wire from switch E lug 4 and connect it to switch F lug 6 (S-1).

- () Remove the gray wire from switch E lug 6. Remove 3/4" of insulation from the wire end. You will connect it later.
- () Remove the jumper wire between switch E lug 6 and switch F lug 5.
- () Remove the two red wires from switch E lug 1 and reconnect them to switch F lug 2 (S-2).
- () Prepare two 1" gray wires.
- () Connect one 1" wire to switch E between lugs 1 (S-1) and 6 (NS).
- () Connect the remaining 1" wire to switch E between lugs 2 (S-1) and 5 (NS).
- () Prepare a 7-1/2" gray wire.
- () Connect one end of the 7-1/2" gray wire to switch E lug 6 (S-2) and the other end to terminal strip AM lug 2 (S-2).

NOTE: When a wire passes through a connection and then goes to another point, as in the next step, it will count as two wires in the solder instructions (S-2), one entering and one leaving the connection.

- () Connect the gray wire, with the 3/4" prepared end, to switch F through lug 5 (S-2) to switch E lug 4 (NS).
- () Prepare the following gray wires:
 - 5"
 - 9-1/4"
- () Connect one end of the 5" gray wire to switch E lug 3 (S-1) and the other end to terminal pin B14 (S-4).
- () Connect one end of the 9-1/4" gray wire to switch E lug 5 (S-2) and the other end to terminal pin E9 (S-2).

This completes the "CW Crystal Wide and Narrow Modification." Proceed to "RF Detector Installation."

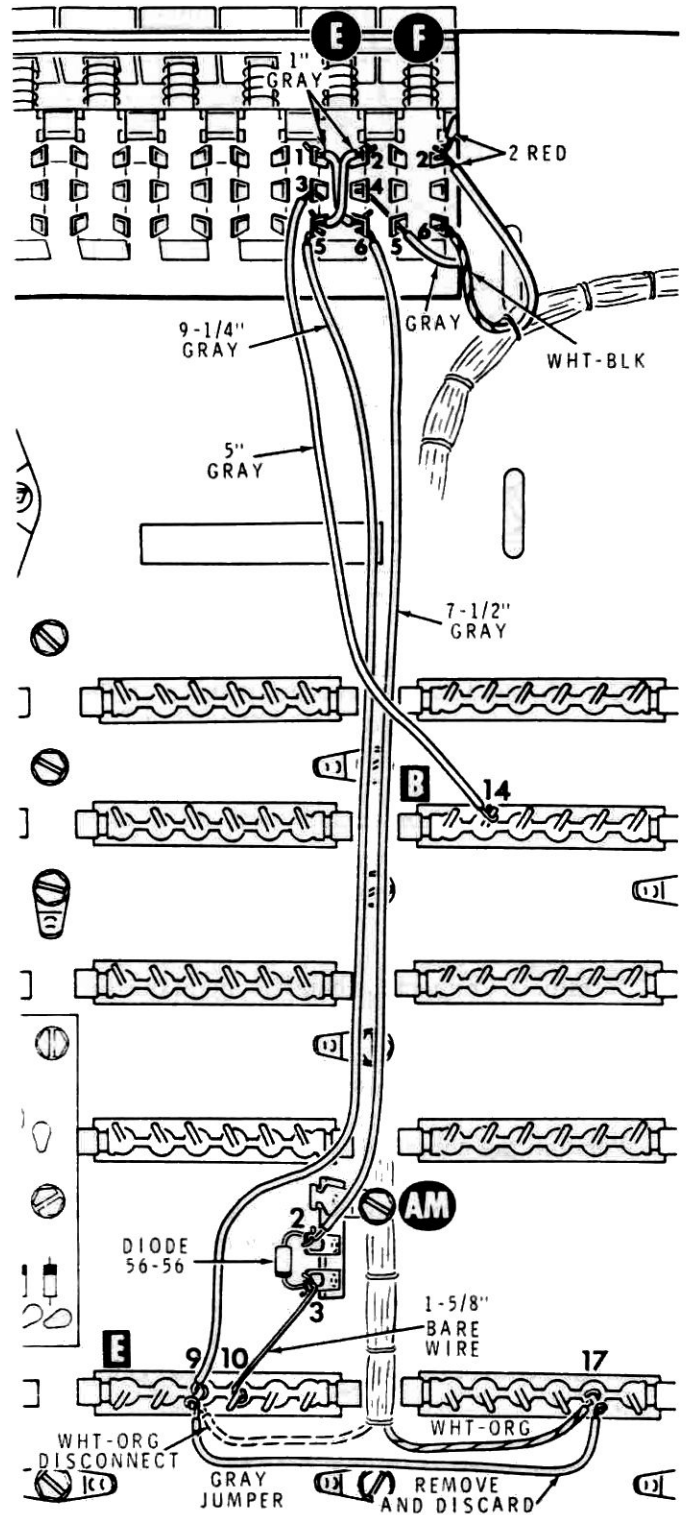

PICTORIAL 16-3

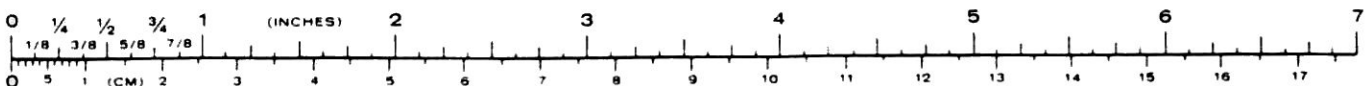

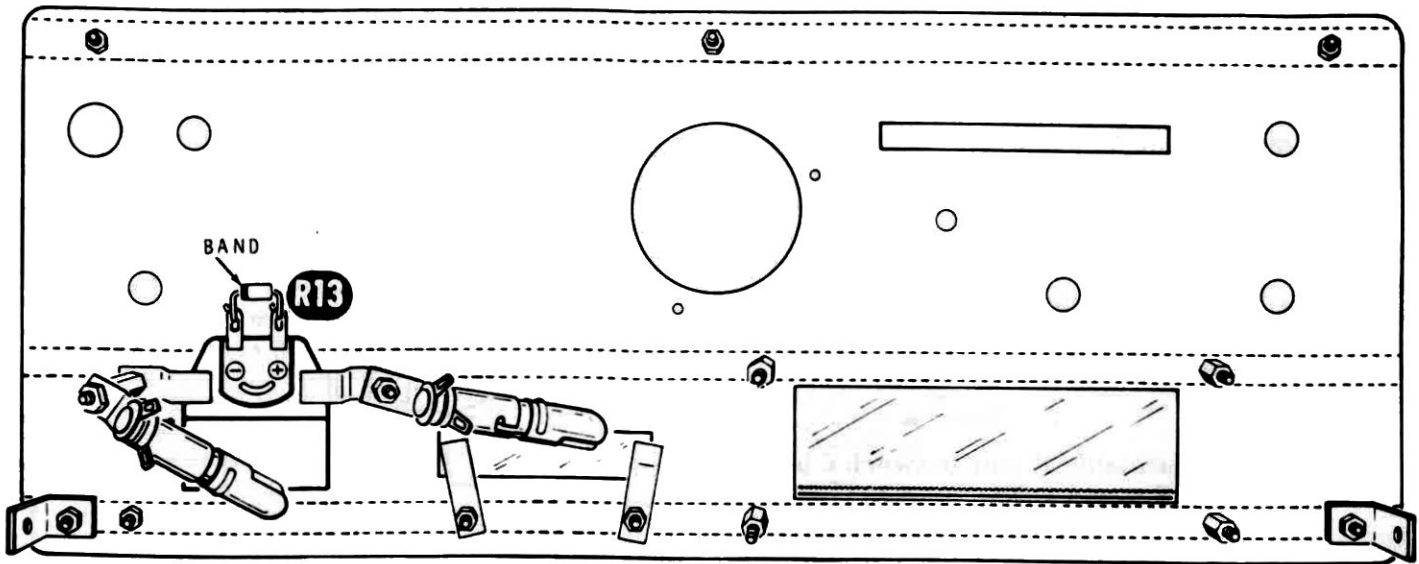
FRONT
PANEL

PICTORIAL 16-4

RF DETECTOR INSTALLATION

Refer to Pictorial 16-4 for the following steps.

- () Position the chassis as shown.
- () Remove the $180\ \Omega$ (brown-gray-brown) resistor across the meter terminals.
- () Install a GD510 diode (#56-89) across the meter terminals. Connect the banded end of the diode to the (-) terminal.

Refer to Pictorial 16-5 for the following steps.

- () Position the chassis as shown.
- () Prepare a 2" gray wire. Remove an extra $1/4$ " of insulation from one end of the wire ($1/2$ " total).
- () Connect the $1/2$ " stripped end of the 2" gray wire to switch B through lug 5 (S-2) to switch A lug 6 (S-1). Connect the other end to switch C lug 5 (NS).
- () Connect a $180\ \Omega$ (brown-gray-brown) resistor between switch C lug 5 (S-2) and switch D lug 5 (NS).
- () Prepare a 2- $1/2$ " gray wire.
- () Connect one end of the 2- $1/2$ " gray wire to switch D lug 5 (S-2) and the other end to switch E lug 4 (S-2).

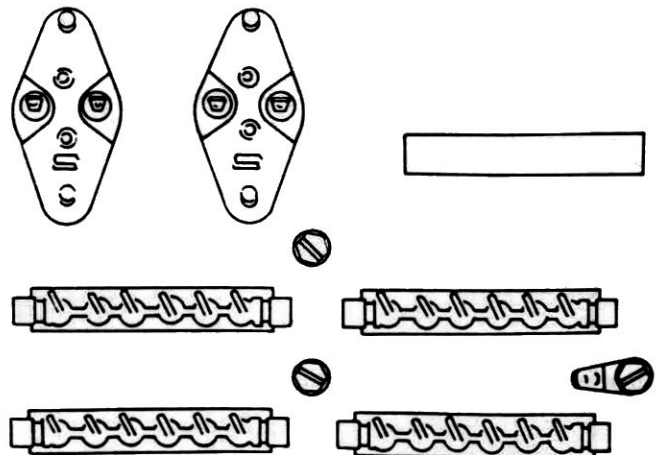
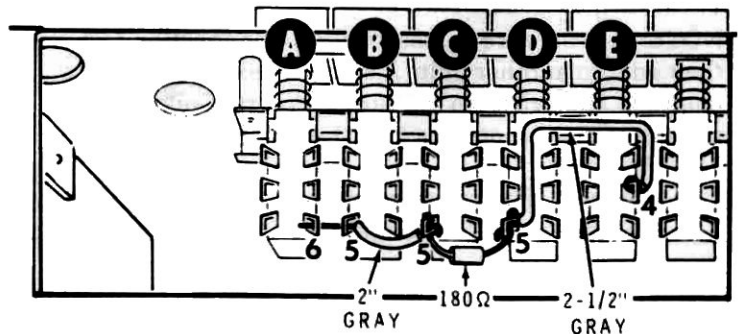

PICTORIAL 16-5

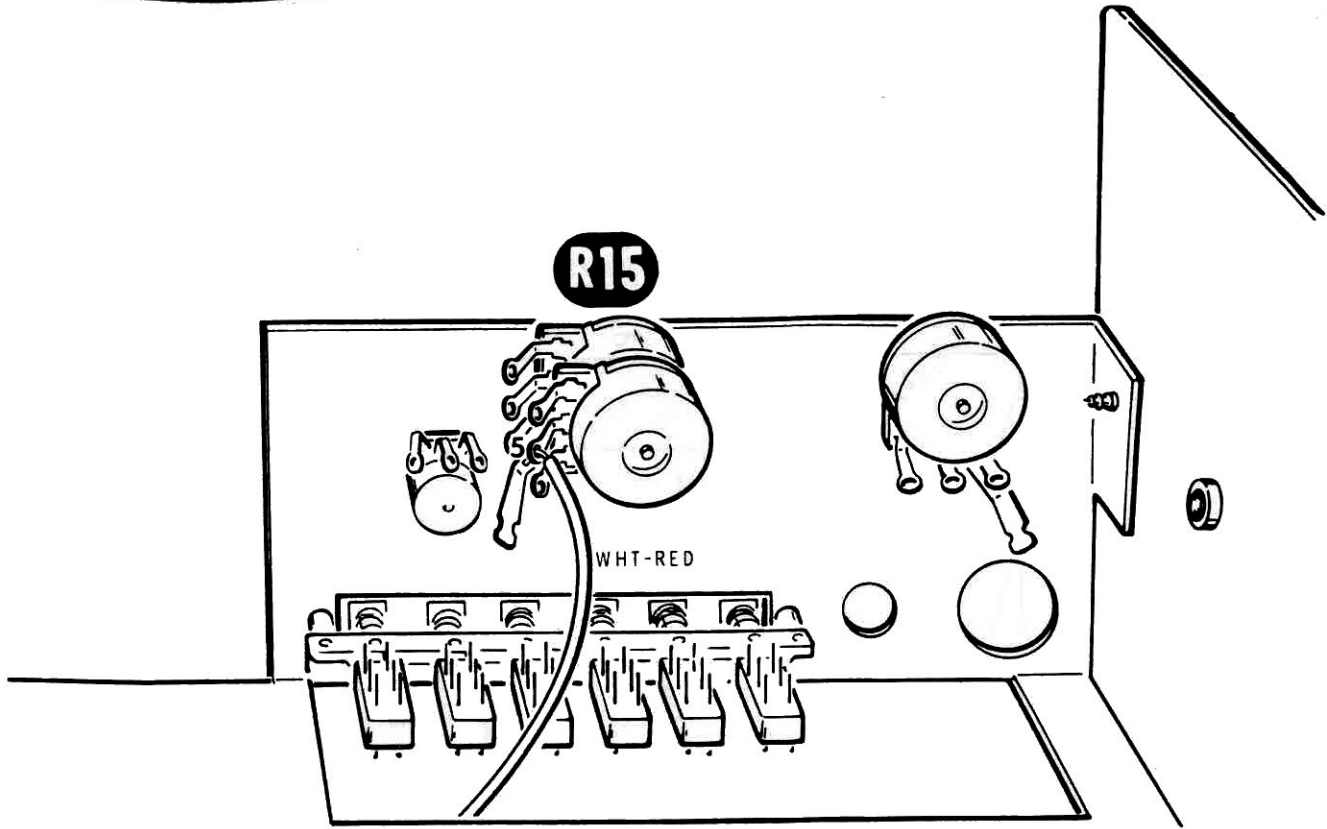

PICTORIAL 16-6

Refer to Pictorial 16-6 for the following steps.

- () Position the chassis as shown.
- () Disconnect the white-red wire at control R15 lug 5 and prepare the end.
- () Refer to Detail 16-6A and connect the white-red wire to switch C lug 2 (S-1).

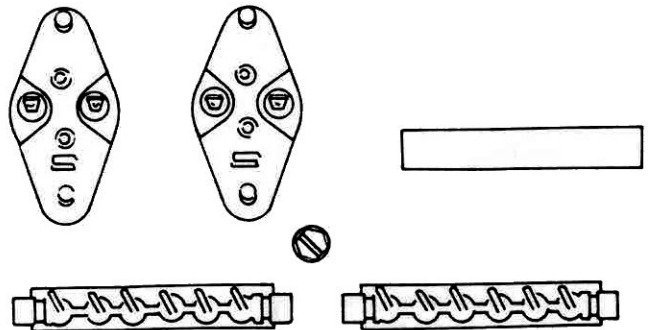
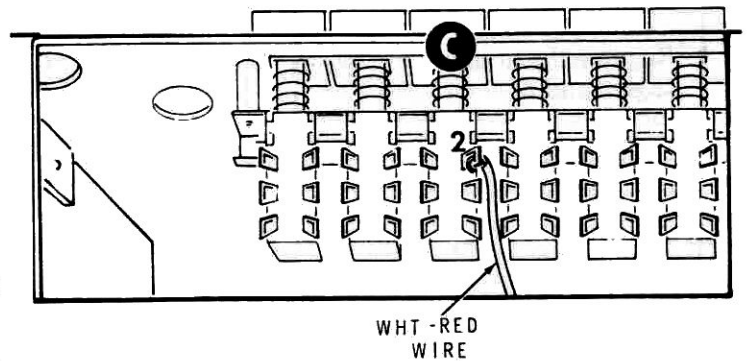

Detail 16-6A



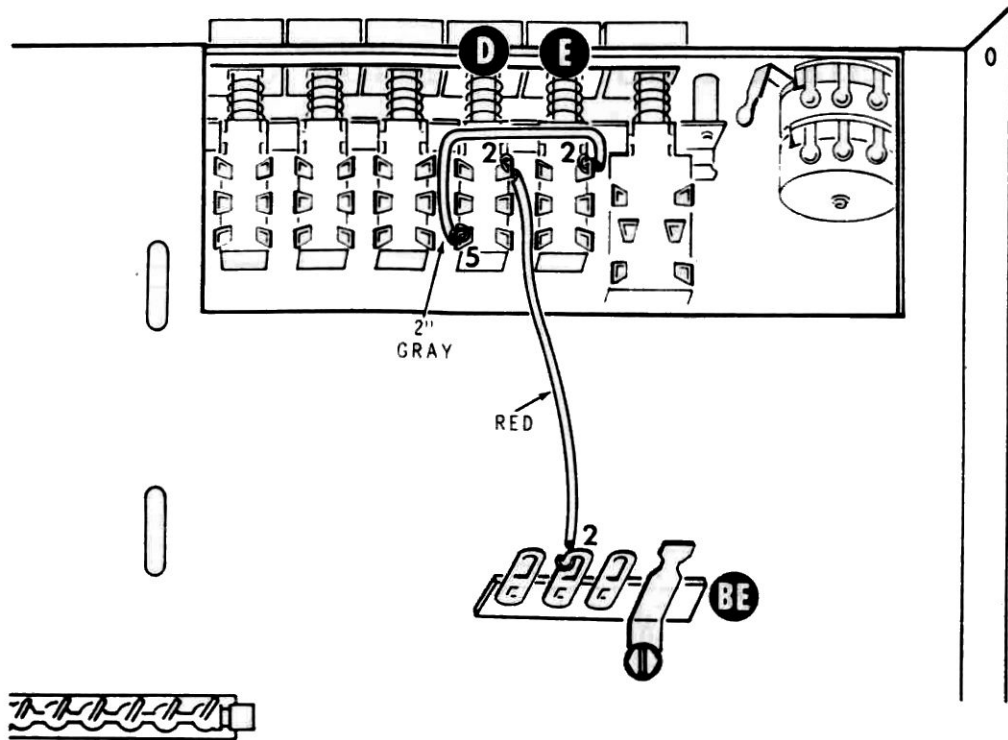

PICTORIAL 16-7

Refer to Pictorial 16-7 for the following steps.

- () Remove the jumper wire at switch D, between lugs 2 and 5.
- () Unsolder the red wire at switch D lug 5 and reconnect it to lug 2 (S-2).
- () Prepare a 2" gray wire.
- () Connect one end of the 2" gray wire to switch D lug 5 (S-1) and the other end to switch E lug 2 (S-3).

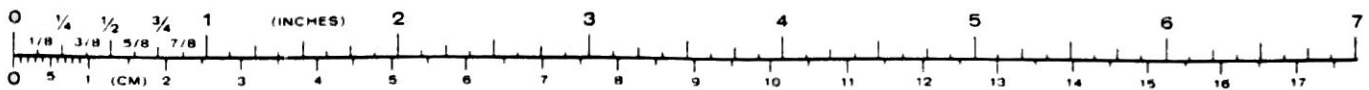

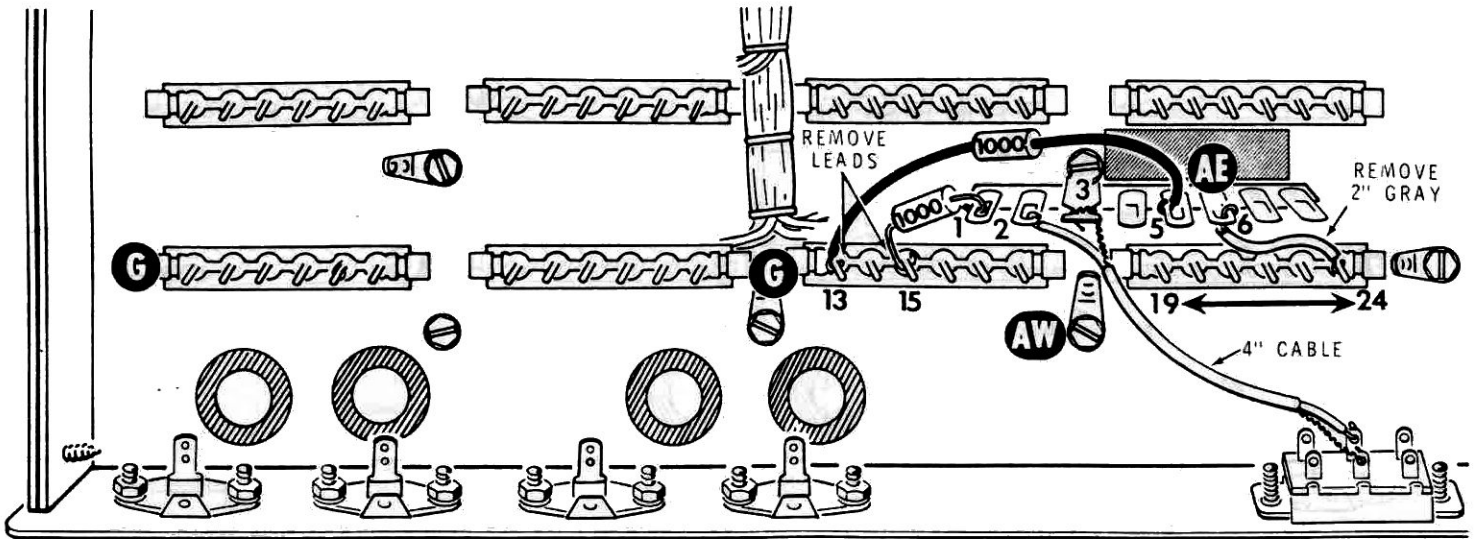

PICTORIAL 17-1

Refer to Pictorial 17-1 for the following steps.

- () Remove both 1 kΩ (brown-black-red) resistor leads at terminal pins G13 and G15.
- () Remove the 2" gray wire at terminal pin G24.
- () Remove both leads of the shielded cable from terminal strip AE lugs 2 and 3.

- () Remove and discard the 8.65 MHz trap (terminal strip AE) from the chassis. Save the screw but do not reinstall it at this time.

Refer to Pictorial 17-2 for the following steps.

- () Position the prepared 4-lug terminal strip as shown.
- () Connect a .01 μF ceramic capacitor between lugs 1 (NS) and 2 (NS).
- () Connect a 150 Ω (brown-green-brown) resistor between lugs 2 (NS) and 3 (NS).
- () Connect a .1 μF Mylar capacitor between lugs 3 (NS) and 4 (NS).
- () Connect the banded end of a 1N191 diode (#56-26) to lug 2 (NS) and the other end to lug 3 (S-3).
- () Connect the banded end of a 1N191 diode (#56-26) to lug 4 (NS) and the other end to lug 2 (S-4).

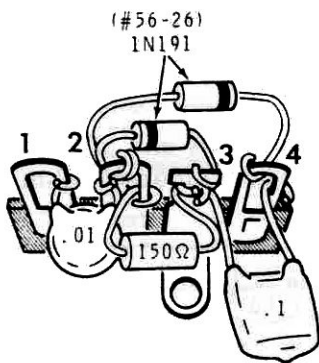

PICTORIAL 17-2

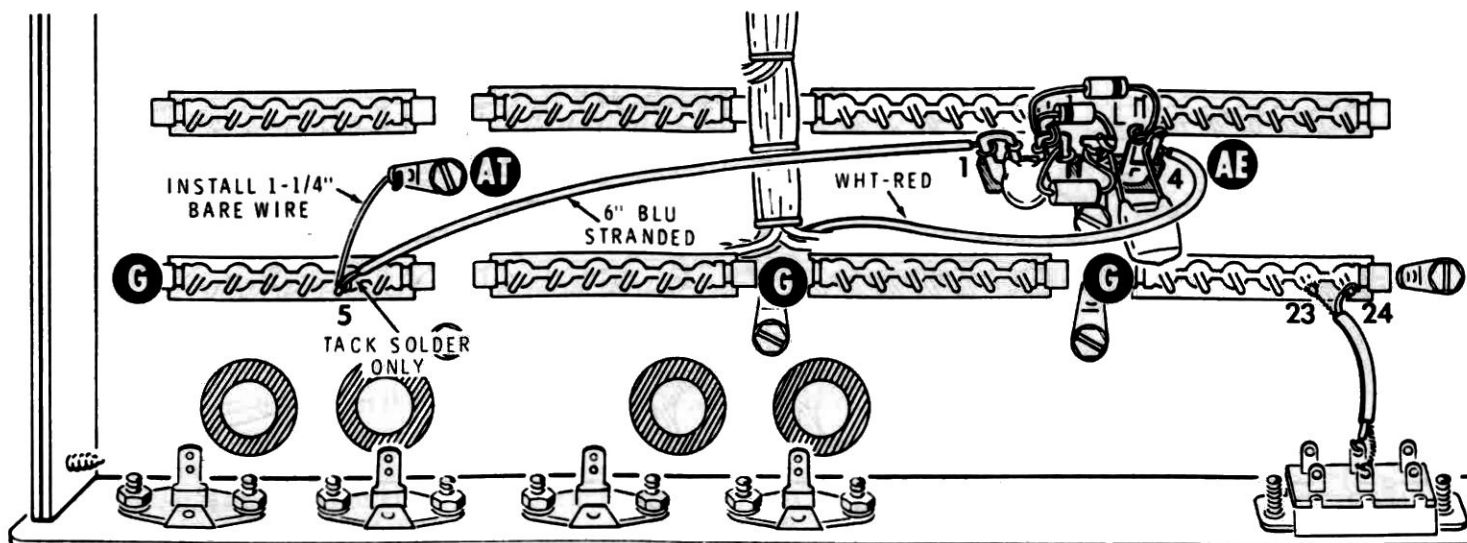

PICTORIAL 17-3

Refer to Pictorial 17-3 for the following steps.

- () Remove the white-red wire from terminal pin G5.
- () Cut a 1-1/4" gray wire and remove all the insulation.
- () Connect the 1-1/4" bare wire from terminal pin G5 (S-1) to solder lug AT (S-6).
- () Reconnect the shield lead from the shielded cable to terminal pin G23 (S-2). Connect the inner lead to terminal pin G24 (S-1). Cut the cable and prepare the end as necessary.
- () Mount the wired 4-lug terminal strip to chassis hole AE with the screw you removed earlier.
- () Connect the white-red wire, which you removed from terminal pin G5, to terminal strip AE lug 4 (S-3). NOTE: Pull the white-red wire through the wire harness if it is not long enough.

- () Prepare a 6" length of blue stranded wire.
- () Connect one end to terminal strip AE lug 1 (S-2).

NOTE: You will use the free end of the blue stranded wire as a probe during the "Alignment" section. In the following step, "tack" solder the connection since the wire will be moved later.

- () Connect the free end of the 6" blue stranded wire to terminal pin G5 (S-2).
- () Turn the chassis over and install the new receiver front end circuit board (G) in your unit.

This completes the "Chassis Changes." Proceed to Pictorial 18-1.

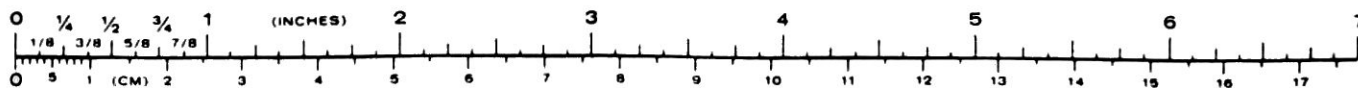

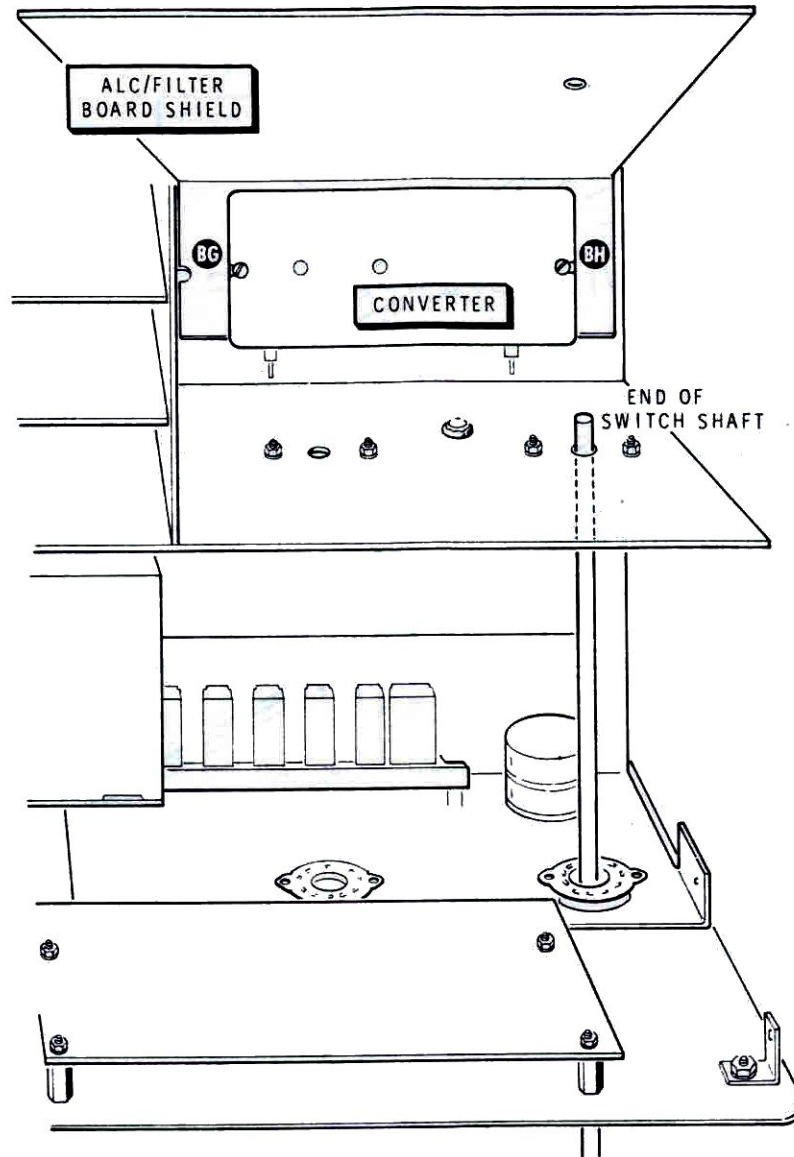

PICTORIAL 18-1

Refer to Pictorial 18-1 for the following steps.

- () Position the chassis as shown.
- () Loosen the collar setscrew on the Band switch shaft. Pull the shaft out so the end is in front of the converter as shown.
- () Remove the ALC circuit board from the chassis.
- () Remove the driver circuit board from the right side panel.
- () Remove the right side panel from the chassis.
- () Remove the converter hardware at BG and BH.
- () Position the ALC/filter circuit board shield under the converter as shown. Then reinstall the converter hardware at BG and BH.
- () Reinstall the ALC circuit board and Band switch shaft. Tighten the setscrew on the collar.
- () Reinstall the right side panel and the driver circuit board on the chassis.

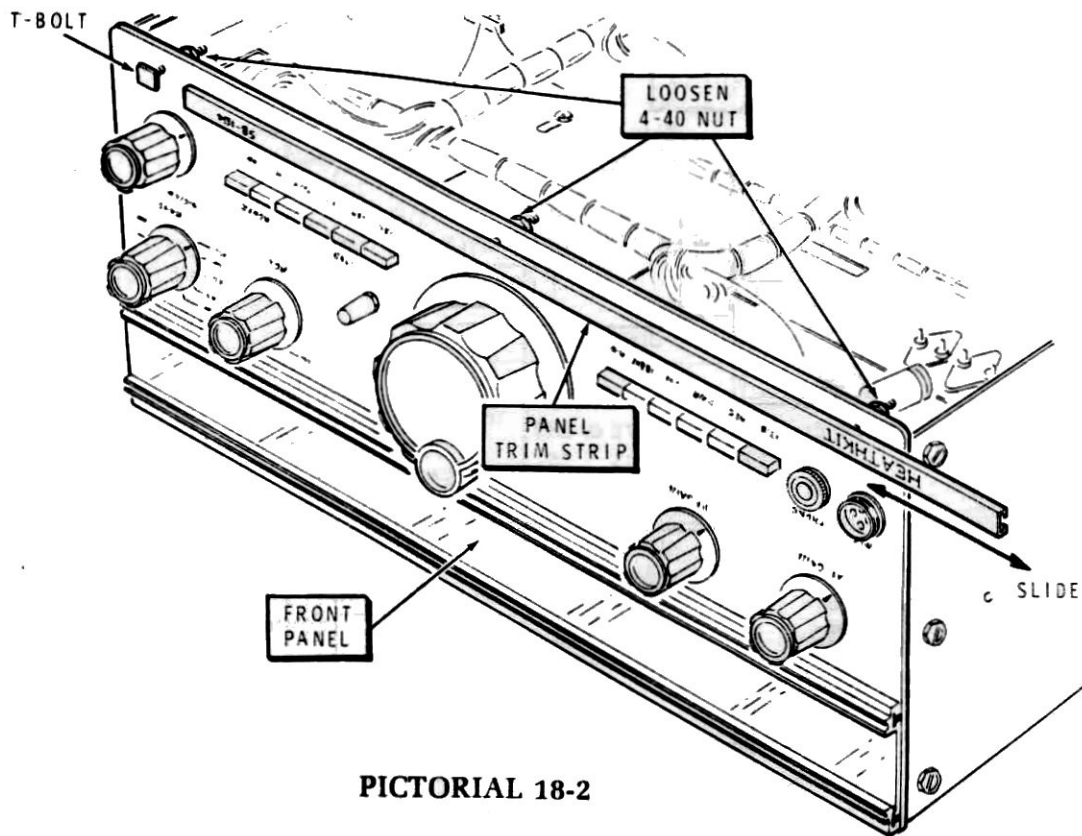

PICTORIAL 18-2

Refer to Pictorial 18-2 for the following steps.

- () Loosen the three 4-40 nuts that hold the front panel trim strip to the front panel.
- () Slide the old trim strip from the three T-bolts and install the new trim strip in its place. Center the trim strip with the front panel and retighten the three 4-40 nuts.

This completes the SBM-104-2 modifications. Proceed to the SB-104A Operation Manual VFO Adjustment section and perform the balance of the "Alignment Procedure."

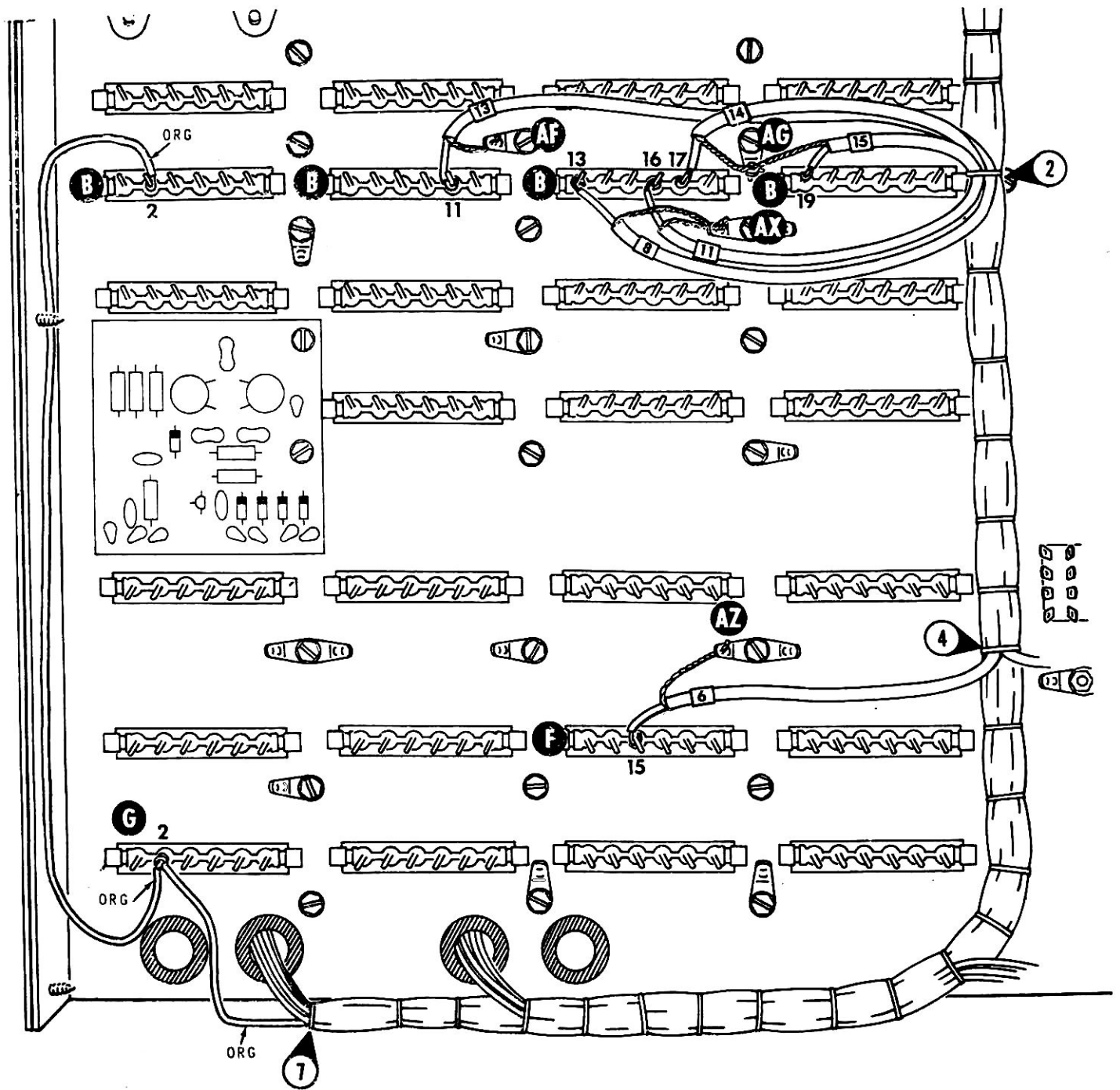

PICTORIAL 12-22

Page 309 in the Operation Manual (fold-out from Page) — Cut out the new part of the Receiver Front End Circuit Board Schematic from Page 4 of these Instructions. Then tape it over the corresponding part of the Schematic in your Manual.

Cut out the new part of the Receiver Front End Circuit Board Schematic from Page 4 of these Instructions. Then tape it over the corresponding part of the large Schematic fold-in.

This completes the modification of your Transceiver.

