



SPECIFICATIONS

MODEL SB-620

SCANALYZER



HEATHKIT

Schlumberger

HEATH COMPANY, BENTON HARBOR, MICHIGAN 49022

PRICES AND SPECIFICATIONS SUBJECT TO CHANGE WITHOUT NOTICE.

PRINTED IN U.S.A.

596-827-01

SPECIFICATIONS

RF AMPLIFIER

Input Frequencies (Receiver IF).....	One of the following: 455 kHz, 1000 kHz, 1600 to 1680 kHz, 2075 kHz, 2215 kHz, 2445 kHz, 3000 kHz, 3055 kHz, 3395 kHz, 5200 to 6000 kHz.
Frequency Response.	±0.5 dB at ±50 kHz from receiver IF.
IF Frequency.	350 kHz.
Sensitivity.	Approximately 10 μv input signal provides a visible signal (40 dB mark) at full pip gain setting.
Spectrum Analyzer.....	Test signal input frequencies up to 50 MHz.

HORIZONTAL DEFLECTION

Horizontal Sweep Generator.	Sawtooth sweep produced by neon lamp relaxation oscillator.
Sweep Rate (Approximate Frequencies).	10 kHz preset: 0.5 Hz. 50 kHz preset: 2 Hz to 2.5 Hz. Variable: 5 Hz to 15 Hz.
Preset Sweep Width.	10 kHz preset: 10 kHz. 50 kHz preset: 50 kHz.

Variable Sweep Width*.....	<u>IF</u>	<u>SWEEP WIDTH</u>
	455 kHz	10 kHz to 100 kHz
	1000 kHz	50 kHz to 500 kHz
	1600 kHz	50 kHz to 500 kHz
	1680 kHz	50 kHz to 500 kHz
	2075 kHz	50 kHz to 500 kHz
	2215 kHz	50 kHz to 500 kHz
	2445 kHz	50 kHz to 500 kHz
	3000 kHz	100 kHz to 500 kHz
	3055 kHz	100 kHz to 500 kHz
	3395 kHz	100 kHz to 500 kHz
	5200 kHz	100 kHz to 500 kHz
	6000 kHz	100 kHz to 500 kHz

*These sweep widths are minimum values. Actual sweep width ranges will be greater than those listed, depending on the receiver IF frequency for which unit is wired.

Resolution. 1 kHz.

NOTE: Resolution is defined as the frequency separation between two equal adjacent signals such that the intersection between their respective pip indications is 30% below the apex amplitude.

Amplitude Scales. Linear: 20 dB (10:1) range.
Log: 40 dB (100:1) range.
-20 dB Log: (Extends calibrated range to 60 dB)

POWER SUPPLY

Type. Transformer operated; fused at 1/2 ampere.

Low Voltage. Full-wave voltage doubler circuit, using four silicon diodes.

High Voltage. Full-wave voltage doubler circuit, using two selenium diodes.

Bias Voltage. Full-wave bridge circuit, using four silicon diodes.

Power Requirements. 120 or 240 volts AC, 50/60 Hz, 40 watts.

GENERAL

Tube Complement. 1 - 3RP7 CRT, high persistence (yellow trace with screen filter).
1 - 6AT6, detector vertical amplifier.
1 - 6AU6, IF Log amplifier.
1 - 6EA8, sweep oscillator, mixer.
1 - 6EW6, RF amplifier.
1 - 6EW6, IF amplifier.
1 - 12AU7, horizontal, push-pull amplifier.

Diode Complement. 8 - Silicon diodes, low voltage rectifier, DC filament rectifier.
2 - Selenium diodes, high voltage rectifiers.
1 - Silicon diode, voltage-variable capacitor.

Cabinet Dimensions. 6-5/8" high x 10" wide x 10-1/2" deep.

Net Weight. 10 lbs.

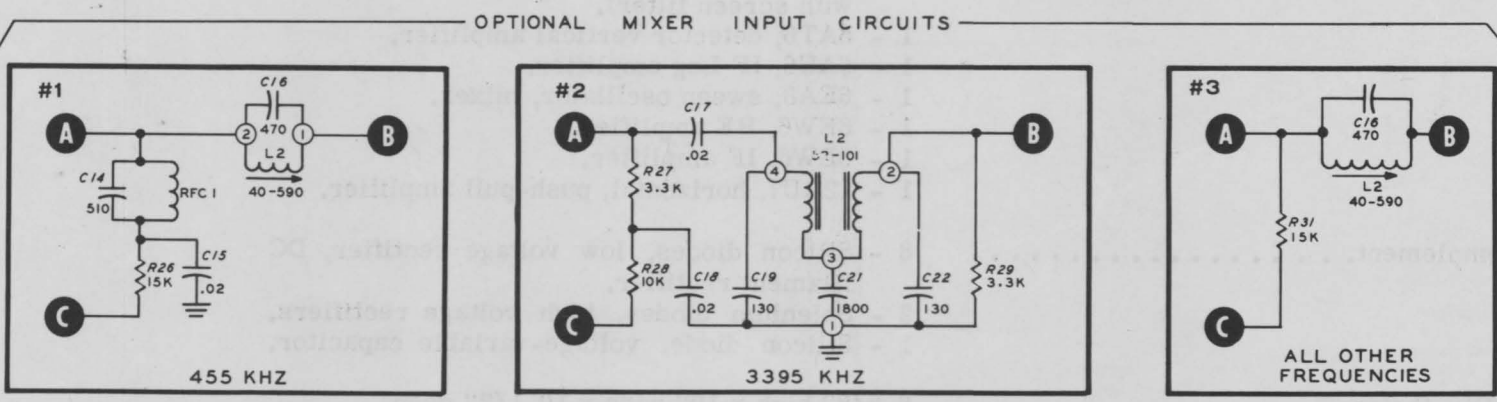
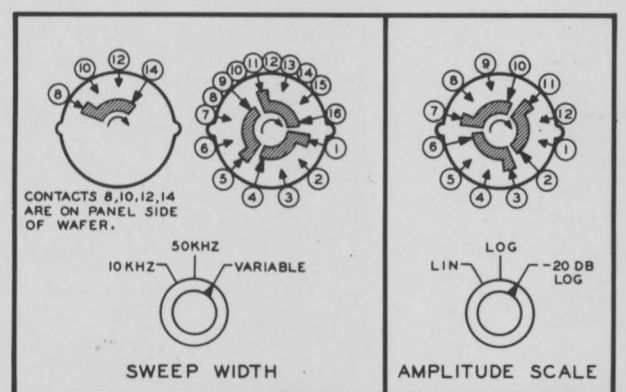
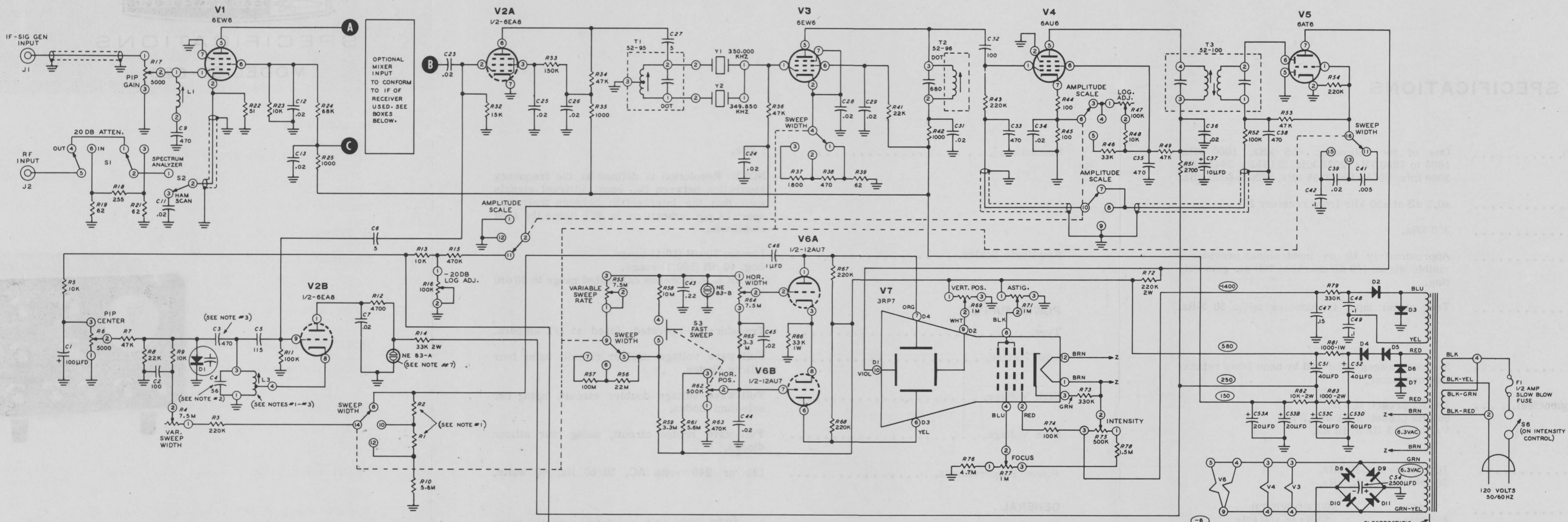

SCHEMATIC OF THE HEATHKIT® SCANALYZER MODEL SB-620

- NOTES:
- SEE IF CHART ON PAGE 75.
 - A. NO CAPACITOR USED ACROSS L3 WHEN WIRED FOR 1000 KHZ.
 - B. WHEN WIRED FOR A RECEIVER IF FREQUENCY OF 455 KHZ, C4 IS 75 pf.
 - WHEN OSCILLATOR COIL 40-775 IS USED AT L3, CHANGE C3 TO 250 pf.
 - CAPACITOR VALUES LESS THAN 1 ARE IN μ fd. VALUES OF 1 AND ABOVE ARE IN pf UNLESS OTHERWISE MARKED.
 - ALL RESISTORS ARE 1/2 WATT UNLESS OTHERWISE MARKED. RESISTOR VALUES ARE IN OHMS (K = 1000, M = 1,000,000).
 - SWITCH WAFERS ARE SHOWN IN FULL COUNTERCLOCKWISE ROTATION AS VIEWED FROM THE REAR. ARROWS SHOW DIRECTION OF COUNTERCLOCKWISE KNOB ROTATION.
 - NE-83-A, VOLTAGE REGULATOR, IS ALSO USED AS THE PANEL "ON" INDICATOR.

