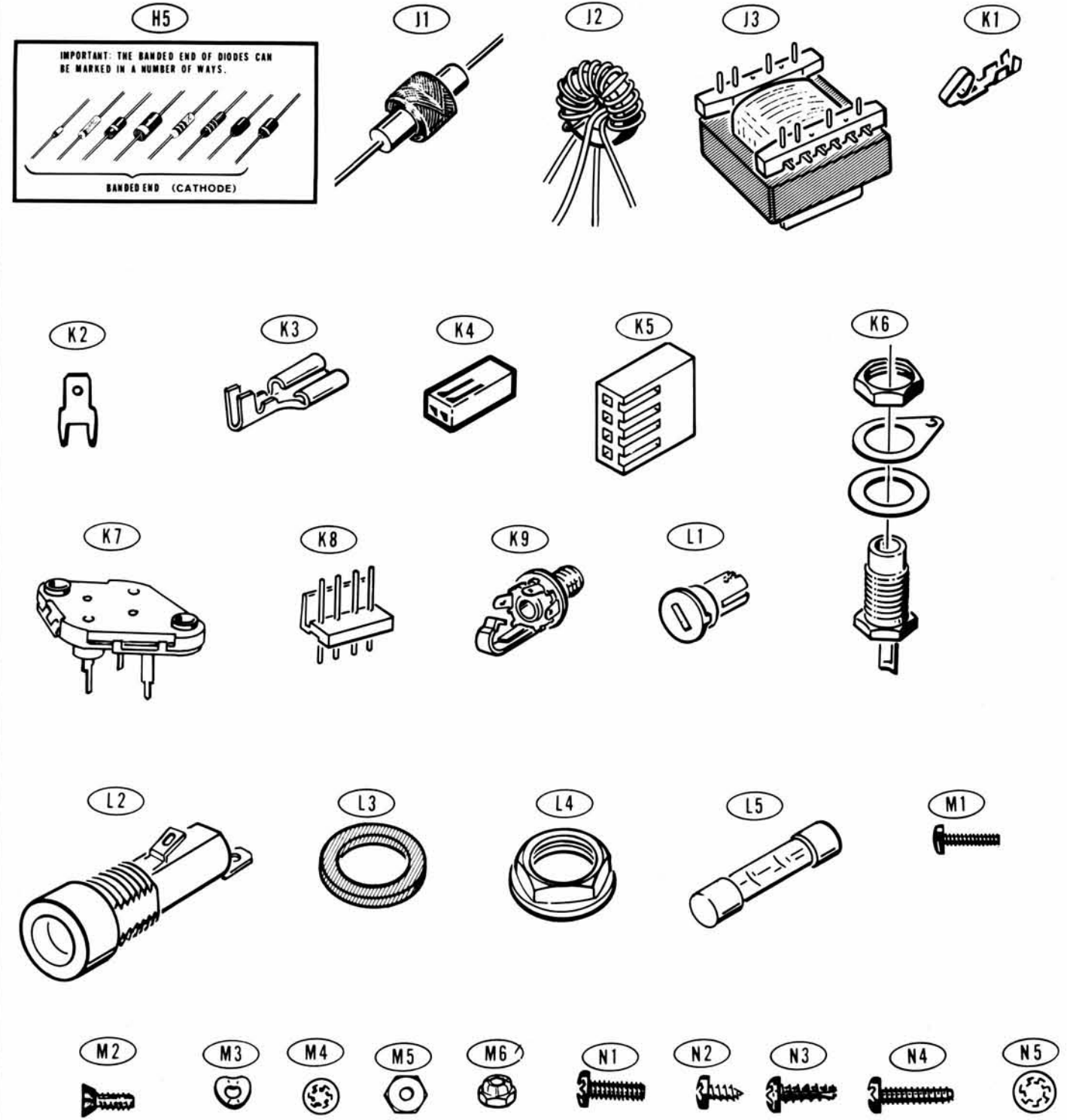
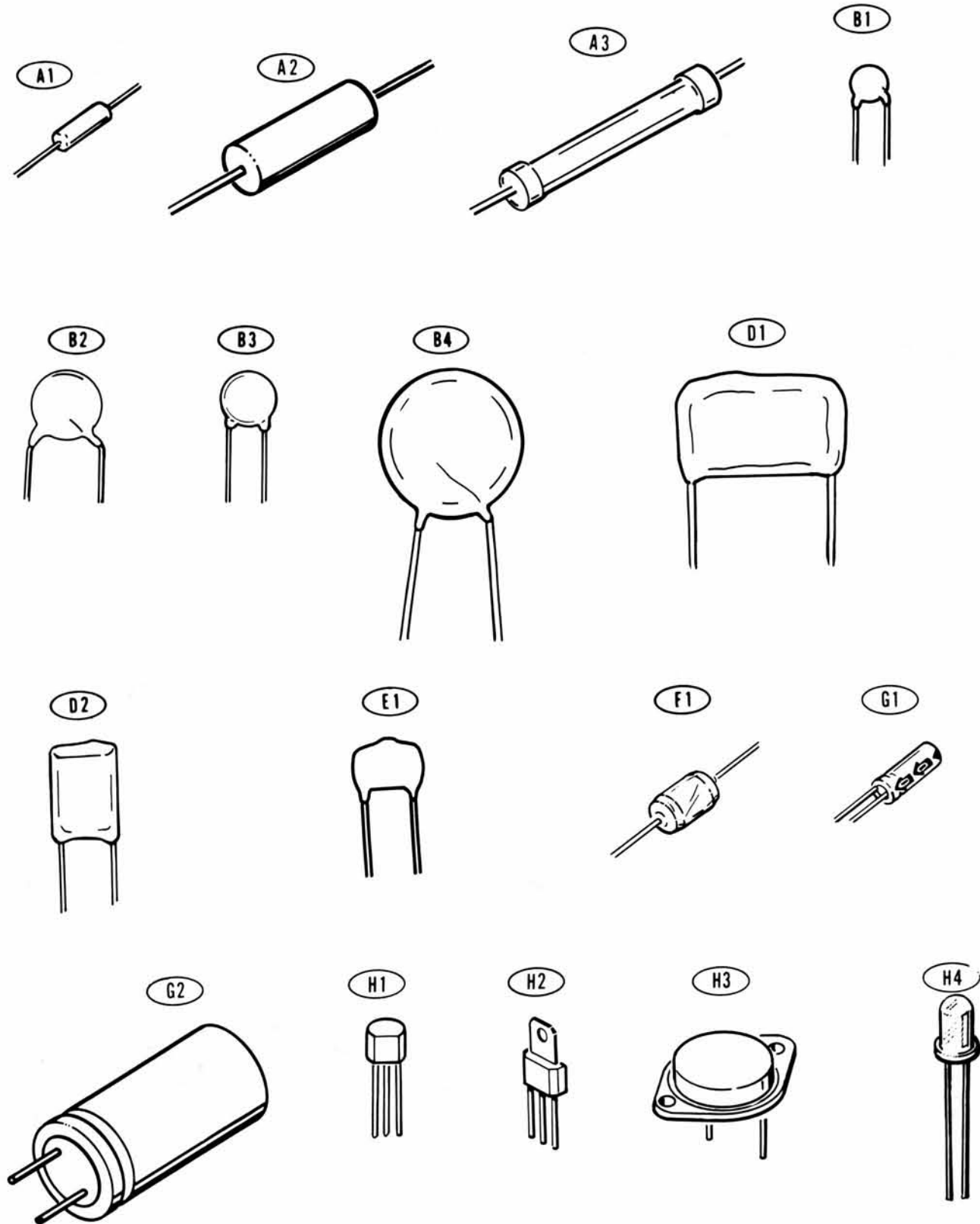
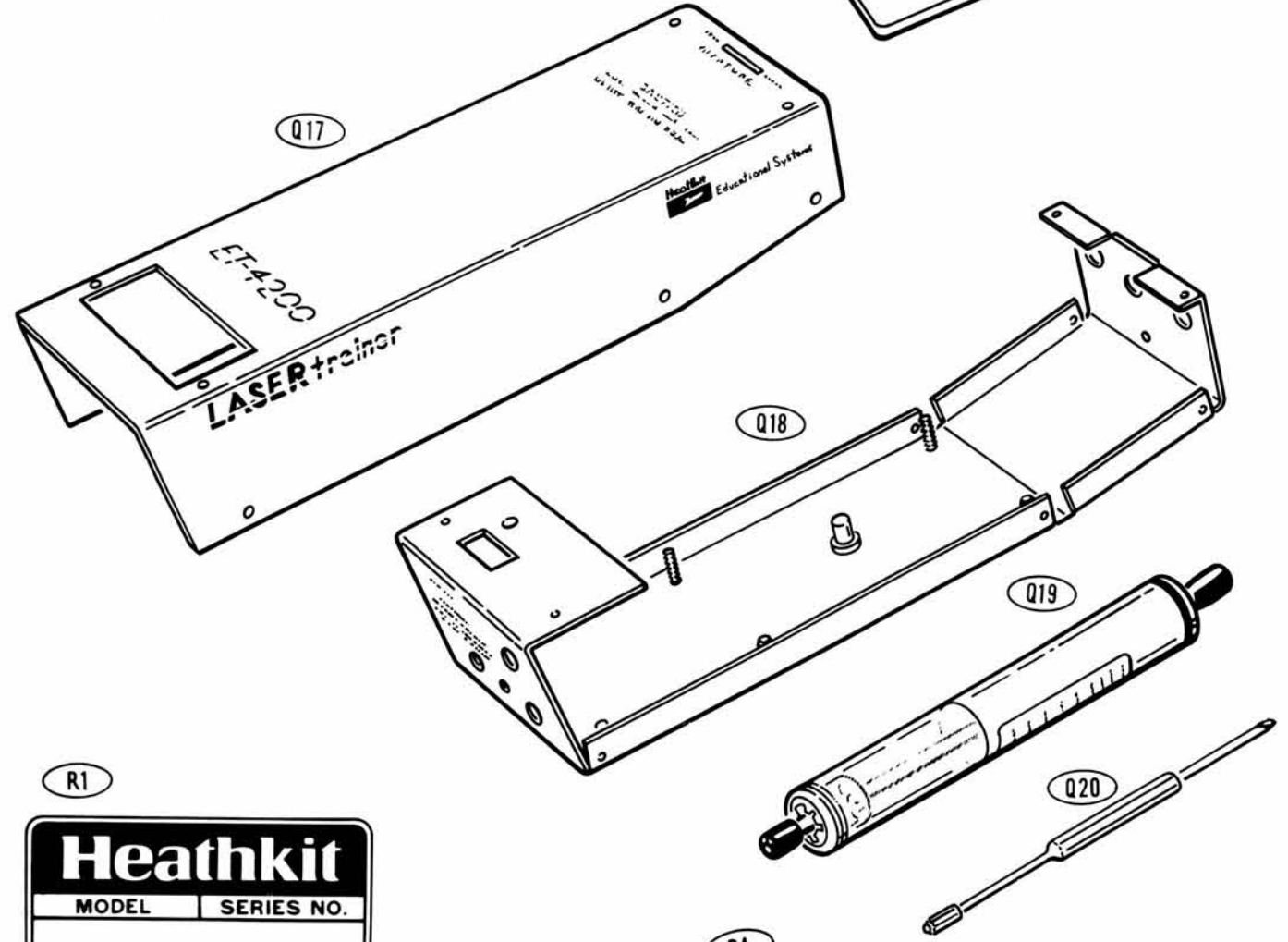
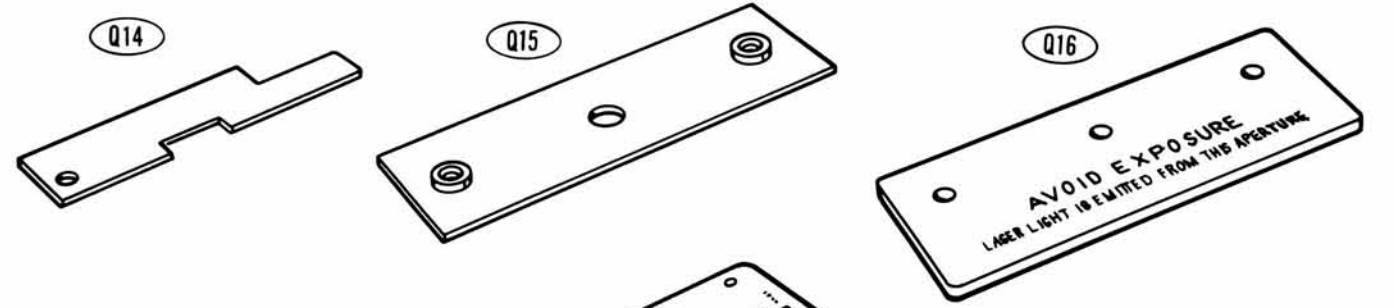
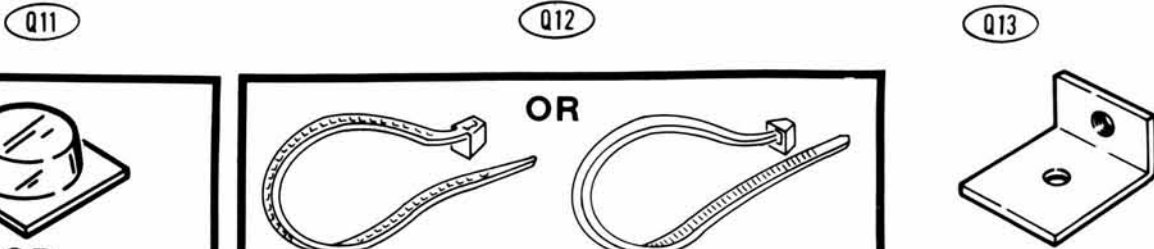
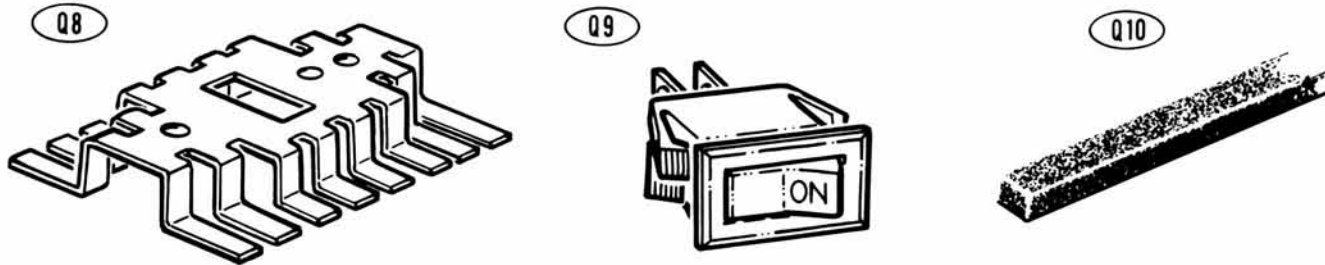
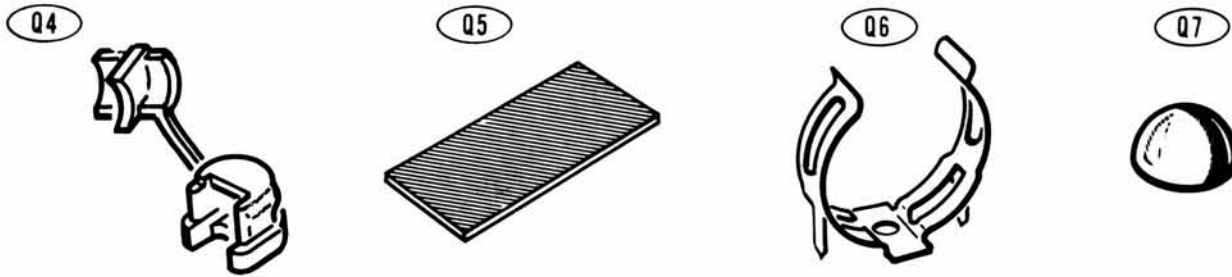
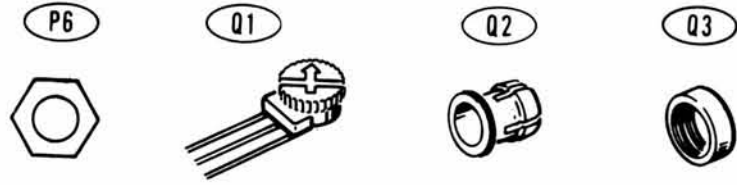
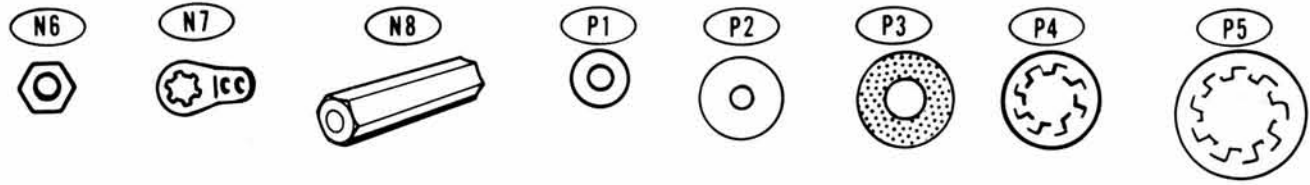

ILLUSTRATION BOOKLET

PARTS PICTORIAL





HEATH COMPANY
BENTON HARBOR,
MICHIGAN 49022
MANUFACTURED
MAY 1984

CAUTION:
NO USER SERVICEABLE PARTS INSIDE.
REFER SERVICING TO QUALIFIED SERVICE
PERSONNEL.
OPENING LASER HOUSING EXPOSES USER
TO HIGH VOLTAGE.

THIS LASER PRODUCT COMPLIES WITH
D.H.S. REGULATION 21 CFR 1040.10
AND 1040.11

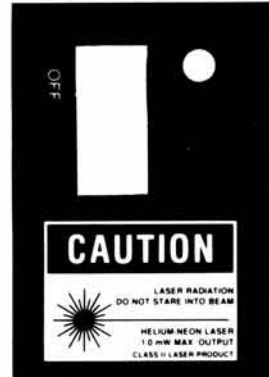

CAUTION
Laser radiation
when open
DO NOT STARE
INTO BEAM

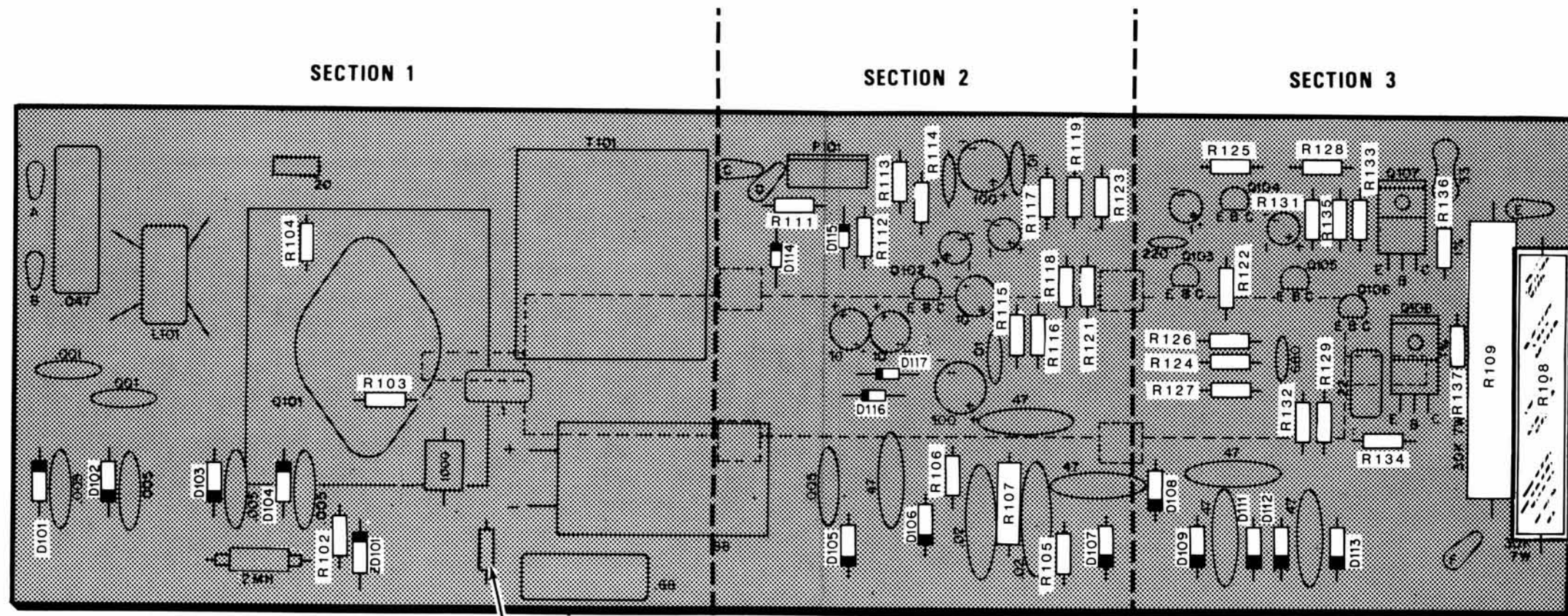

NOTE: No component will be installed at this location.

PICTORIAL 1-1

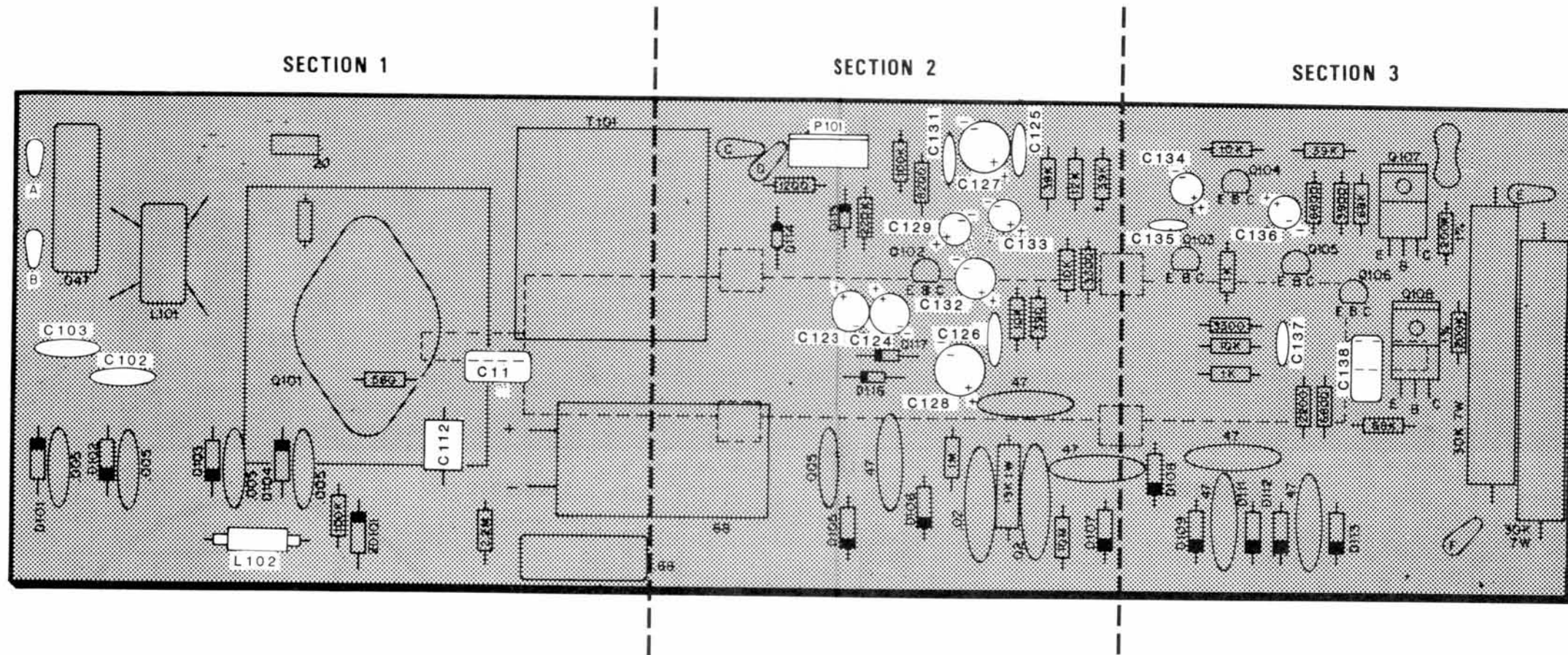

PICTORIAL 1-3

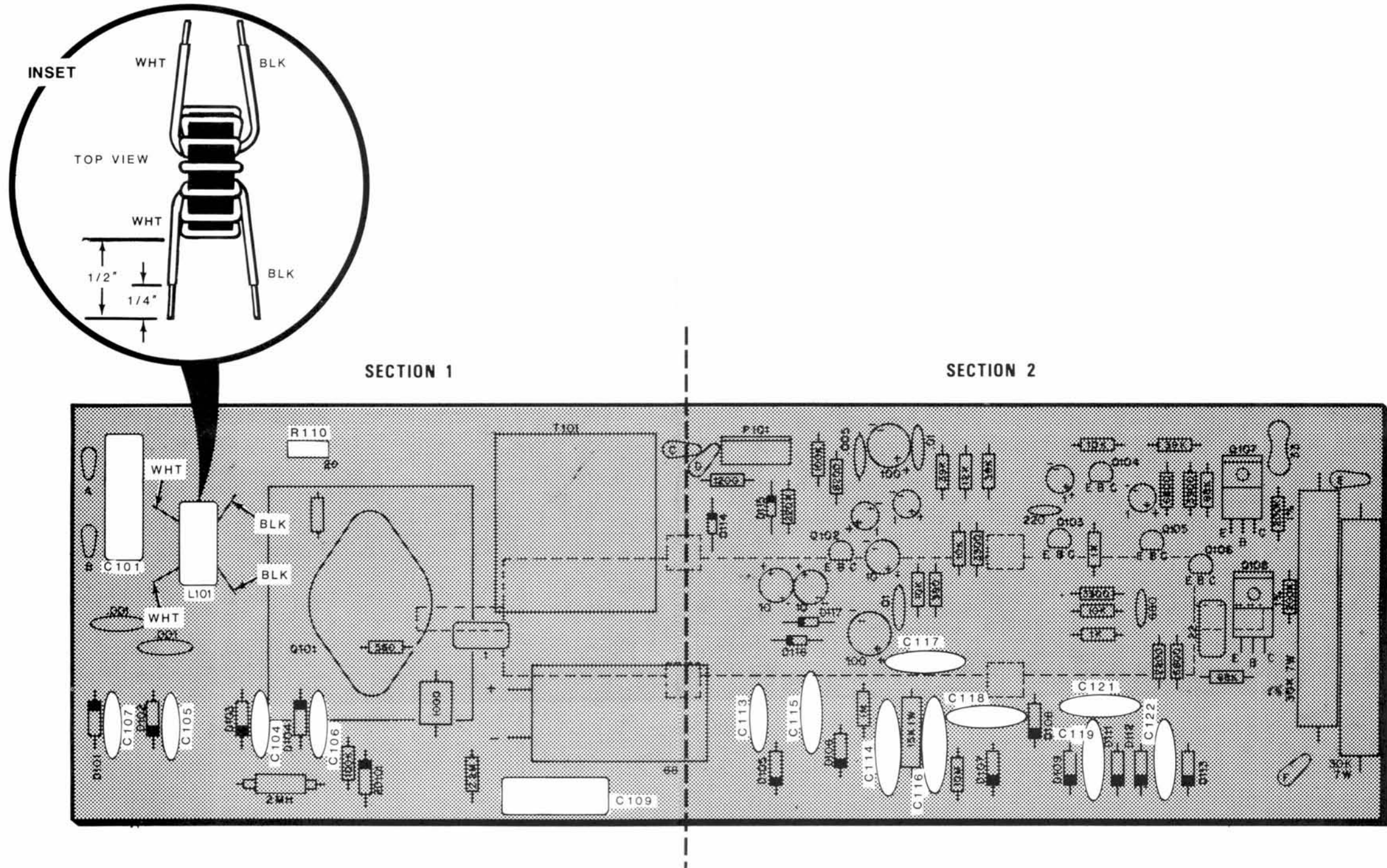

PICTORIAL 1-4

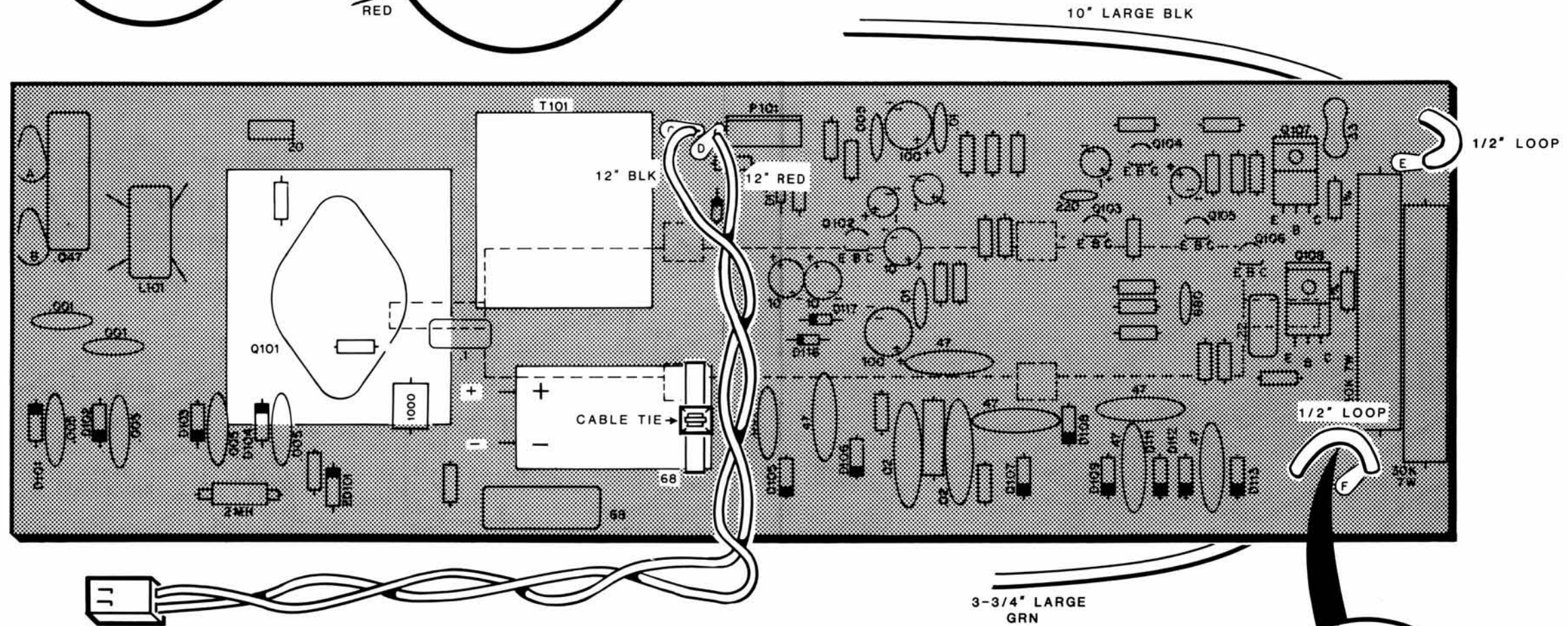
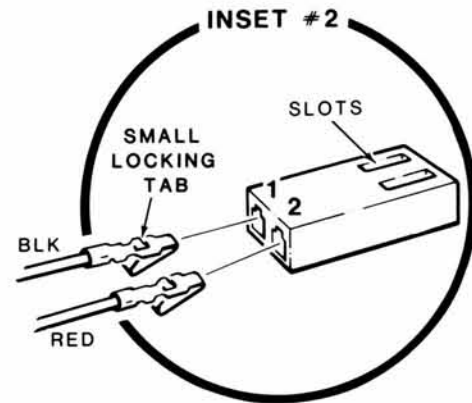
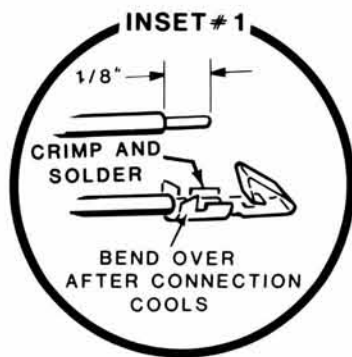

PICTORIAL 1-5

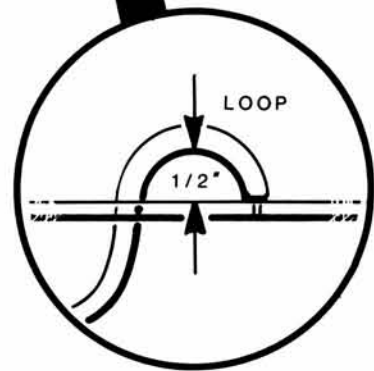

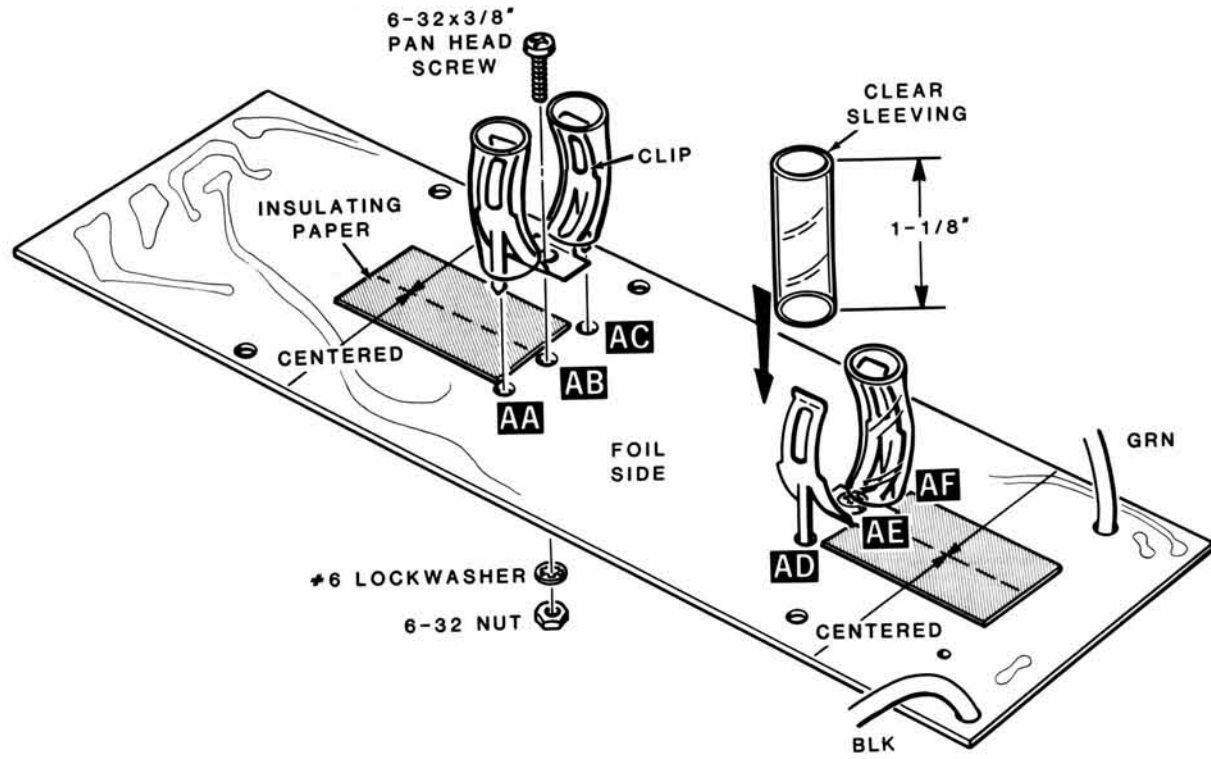

PICTORIAL 1-6

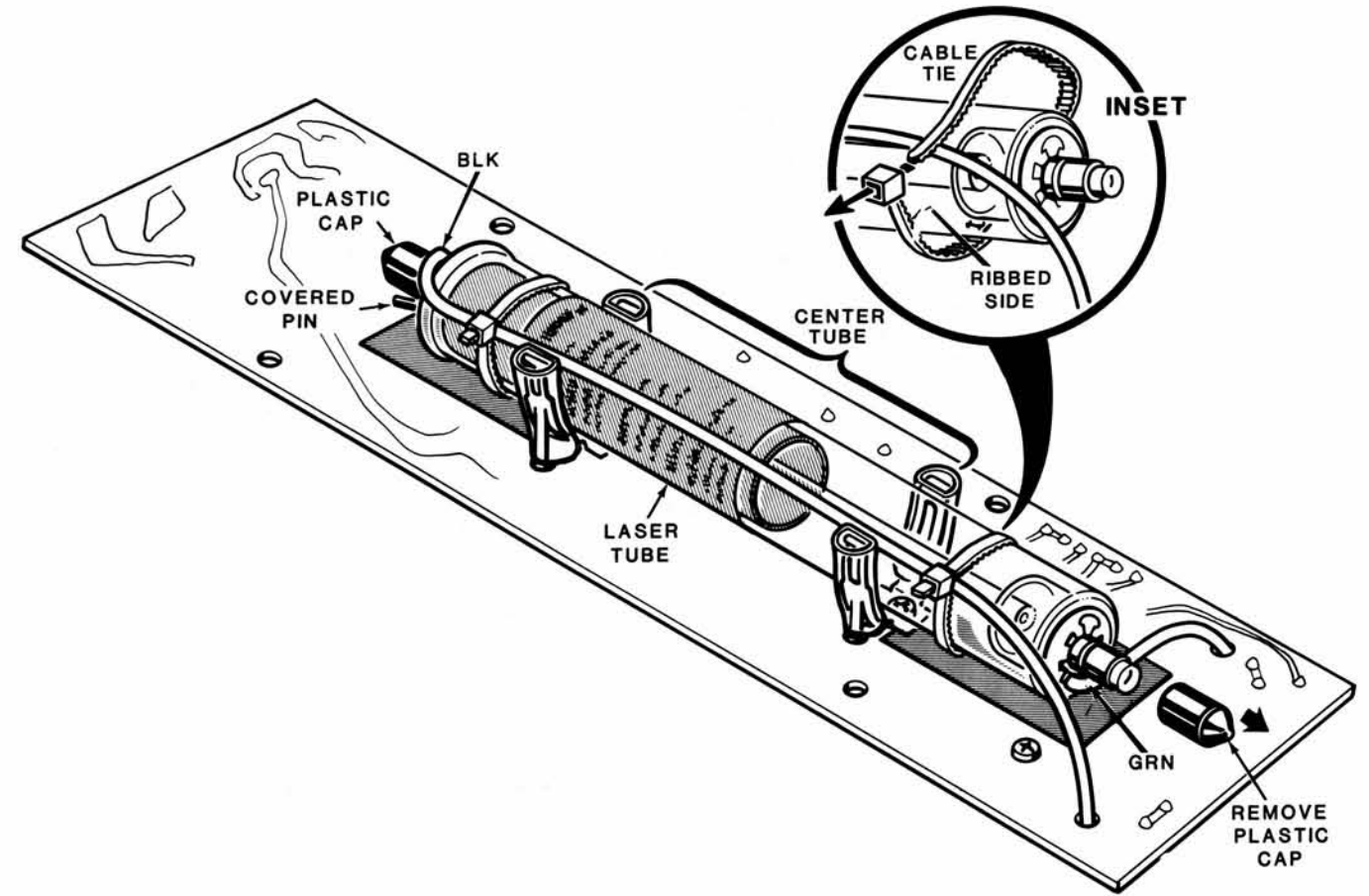

PICTORIAL 1-7

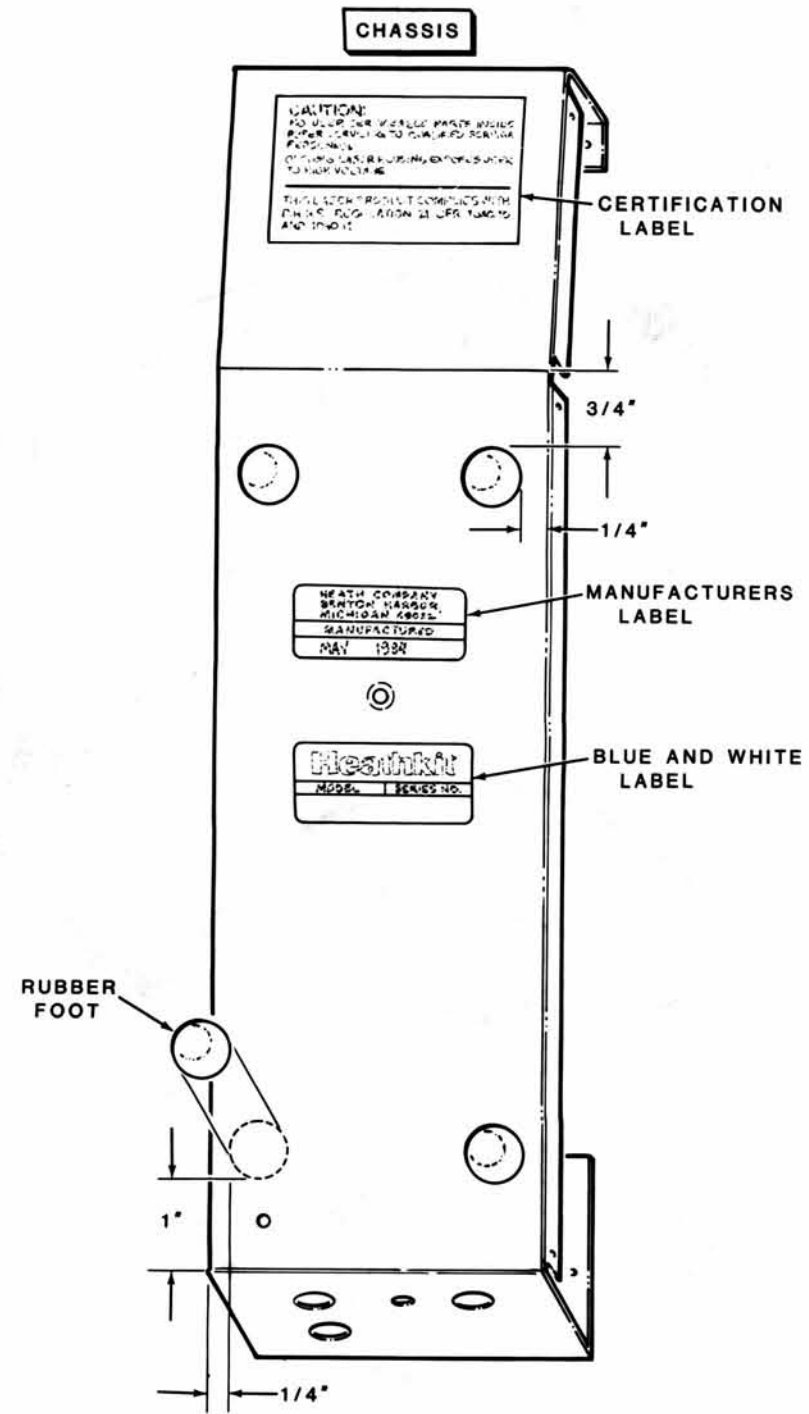

PICTORIAL 2-1

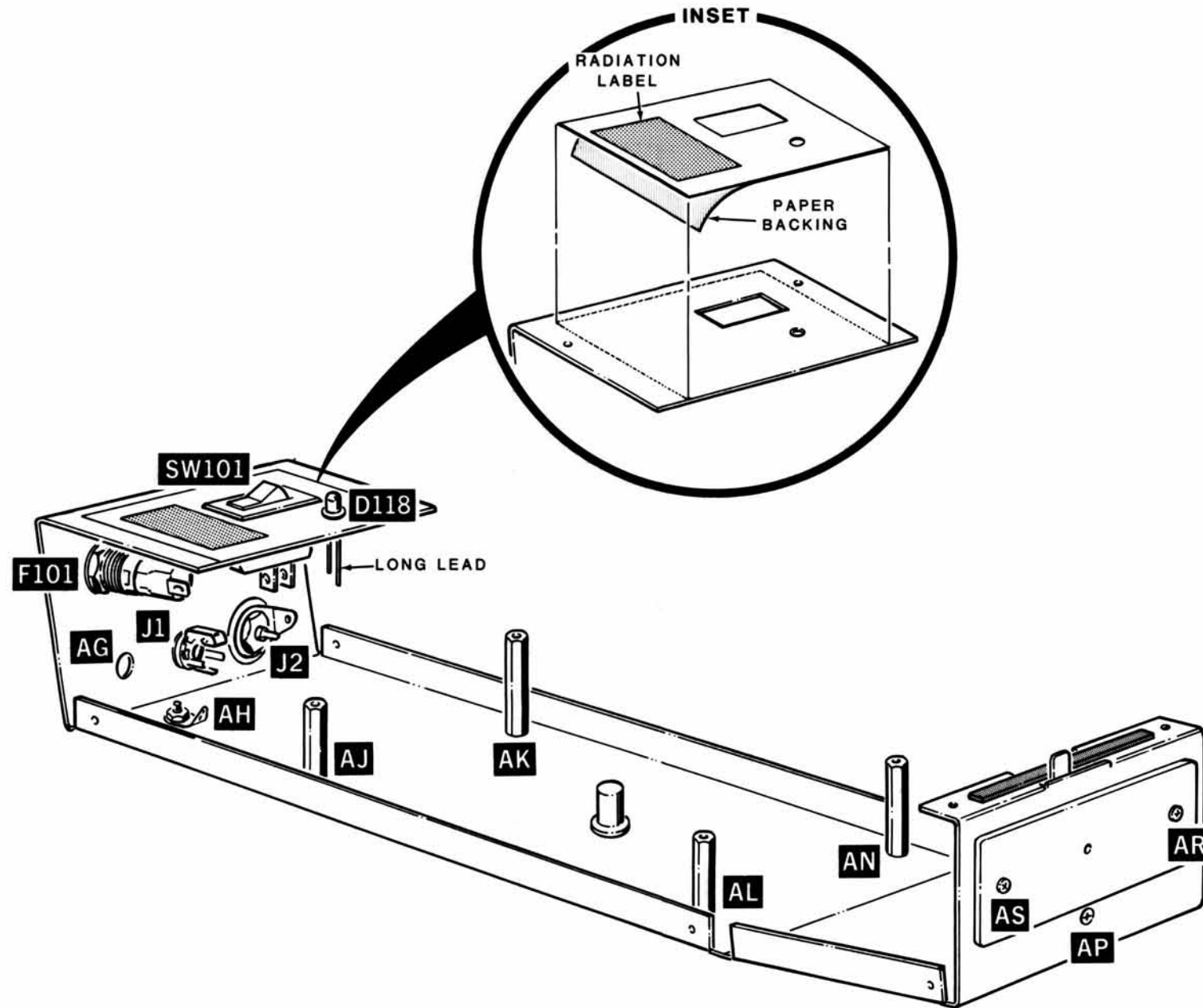

PICTORIAL 2-2

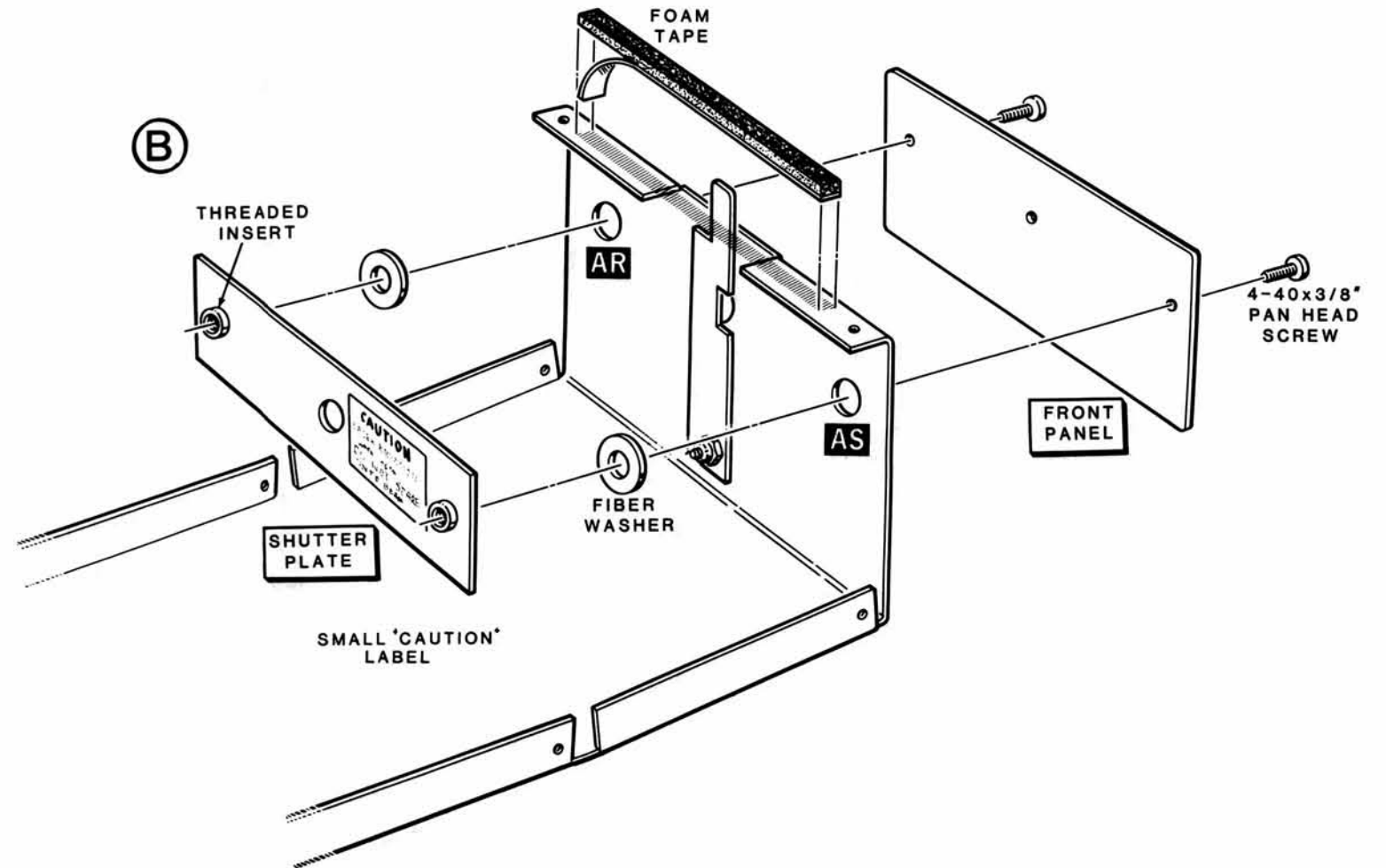
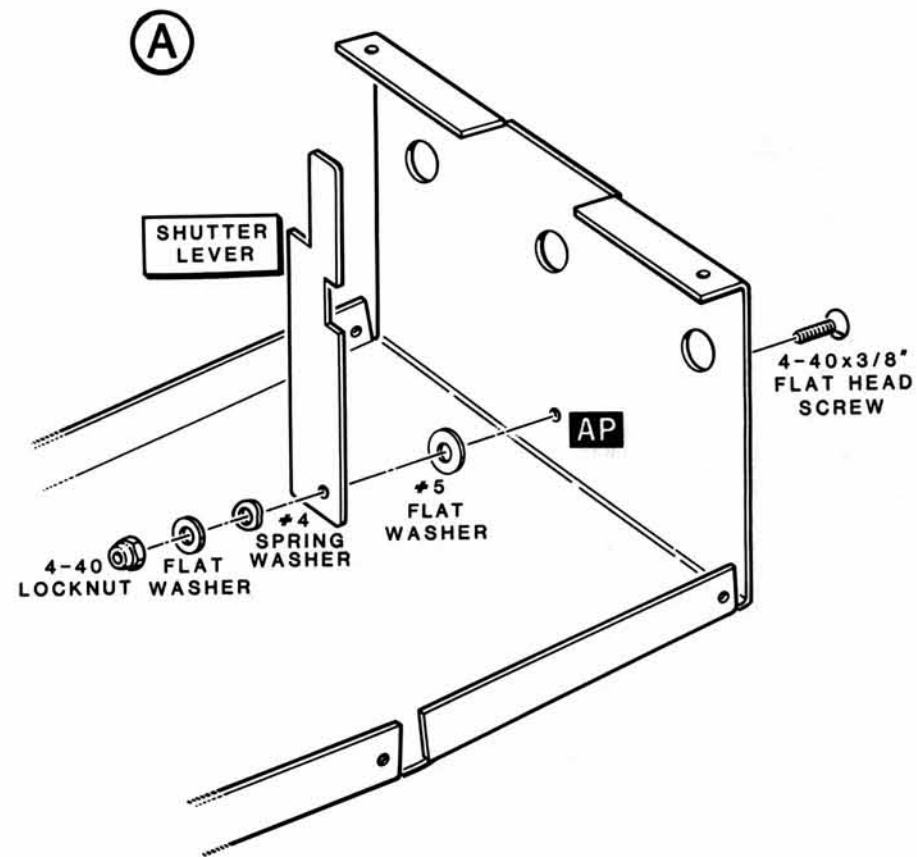

Detail 2-2H

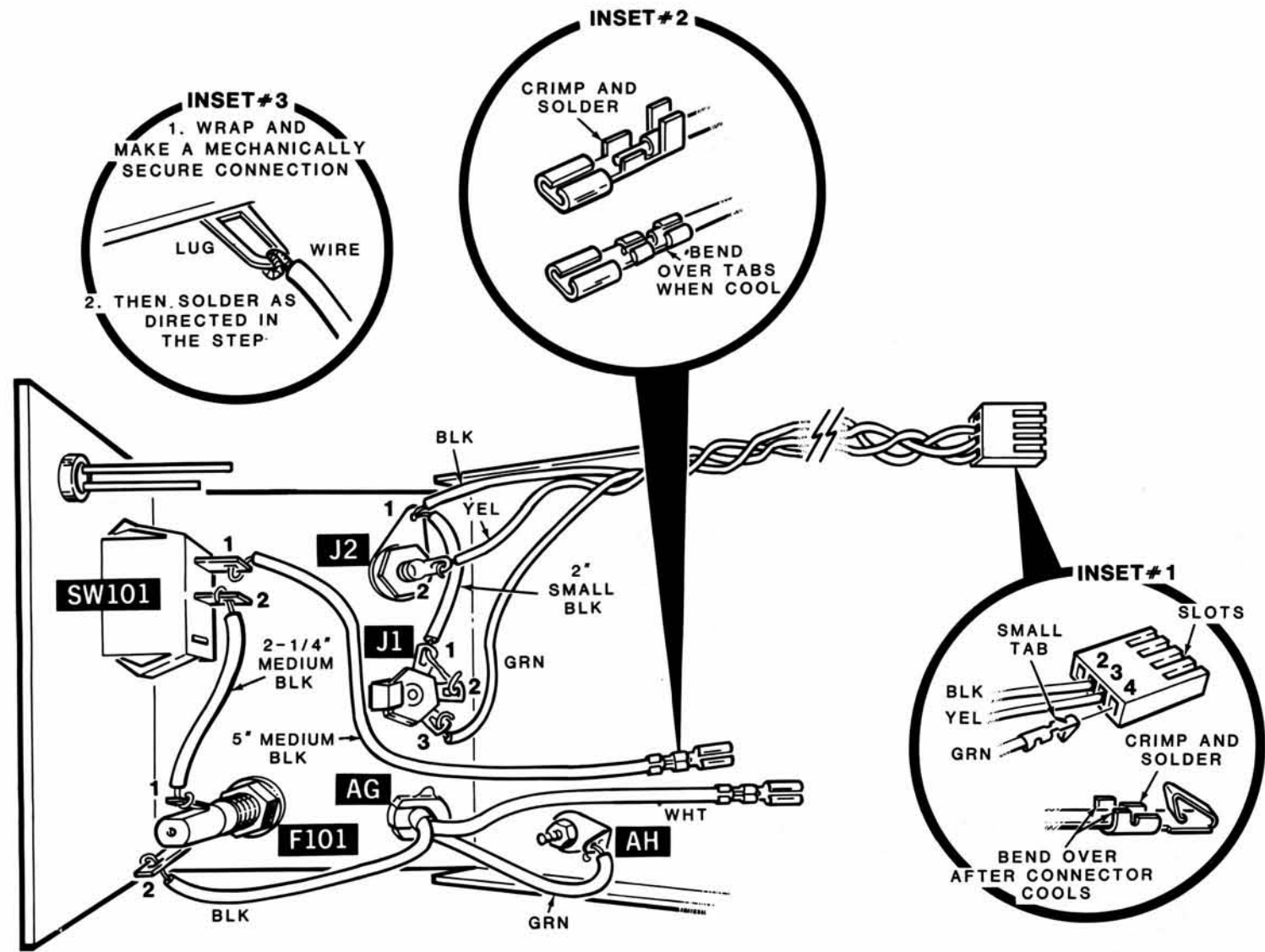

PICTORIAL 2-3

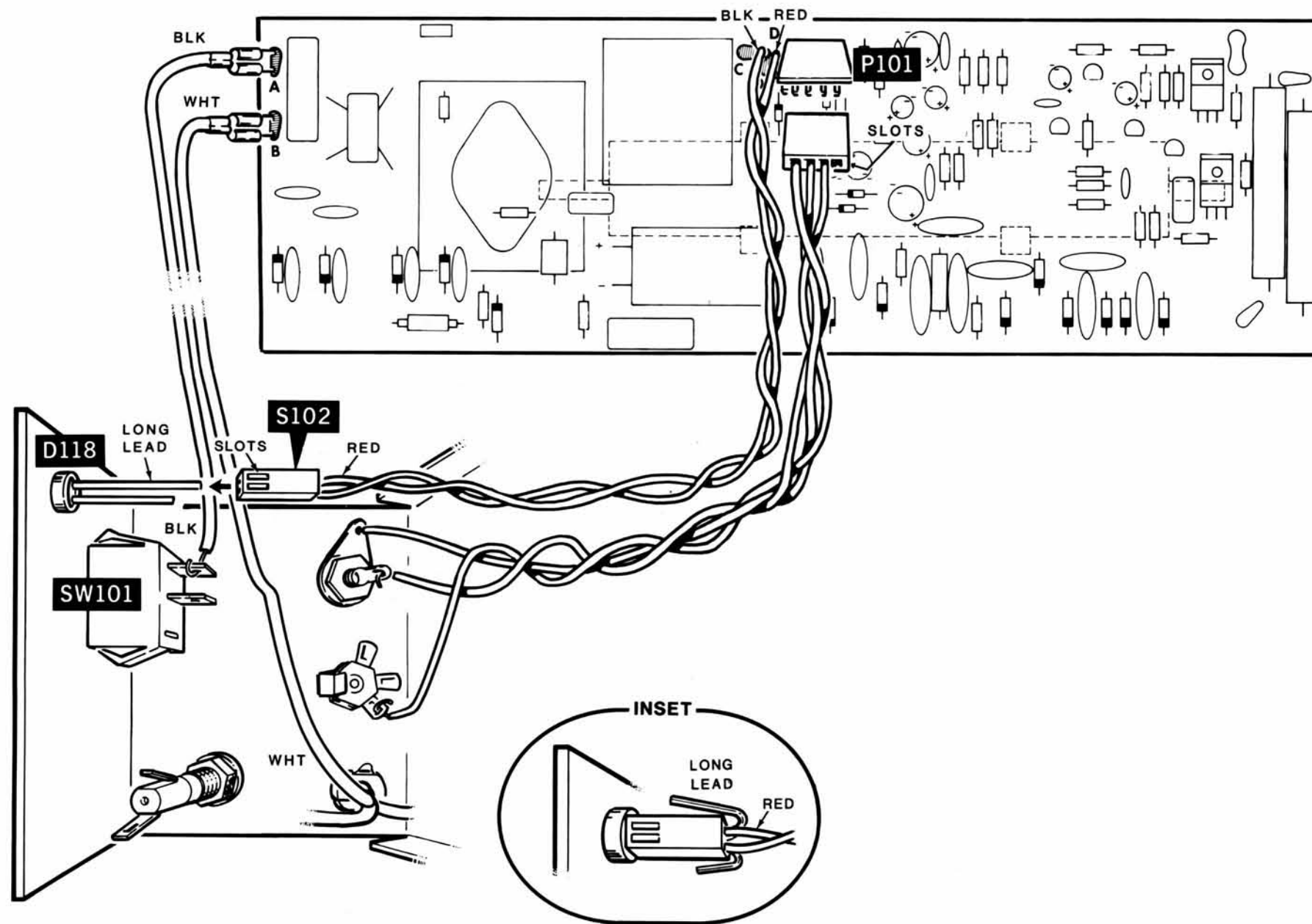

PICTORIAL 2-4

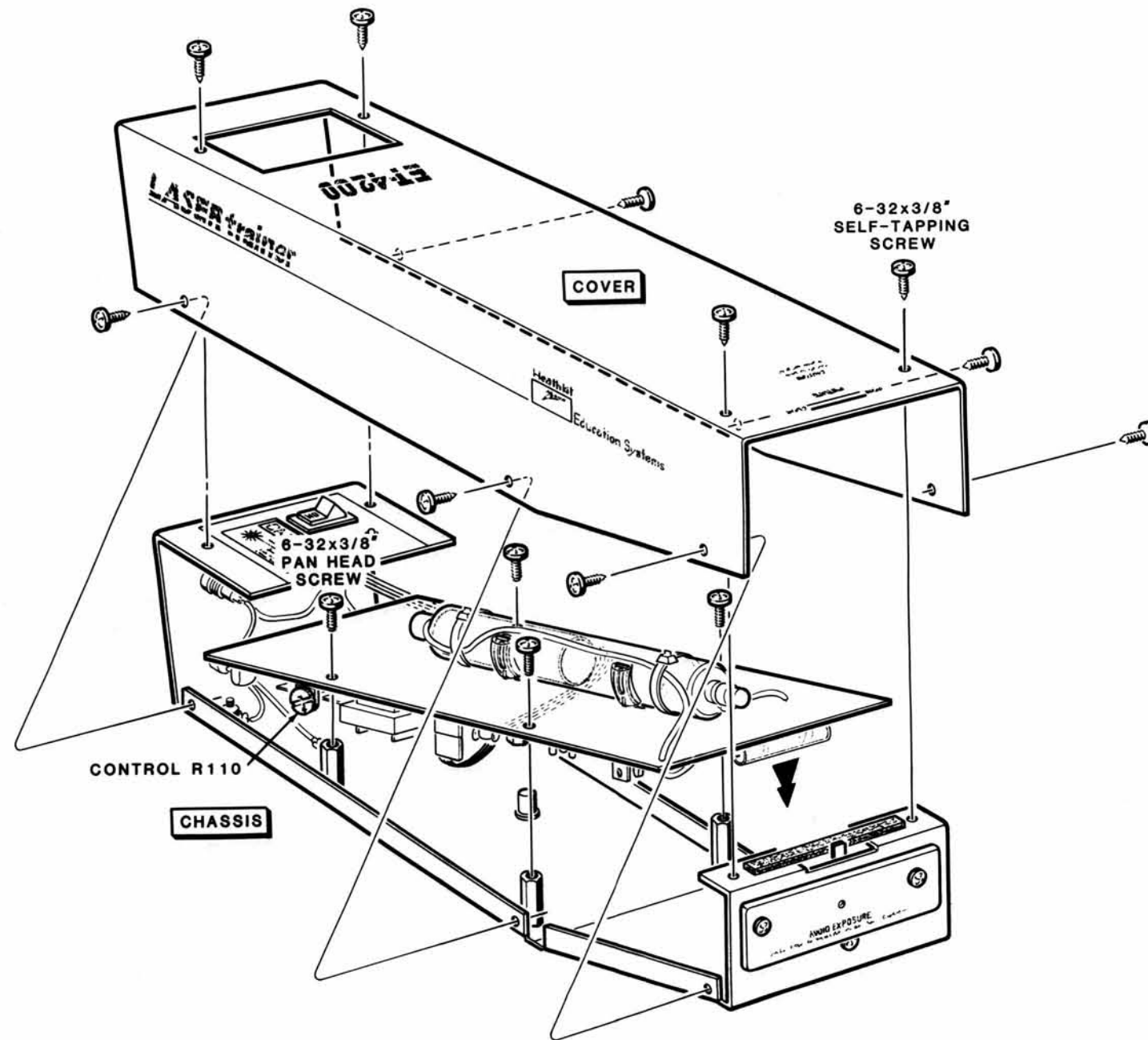

PICTORIAL 2-5

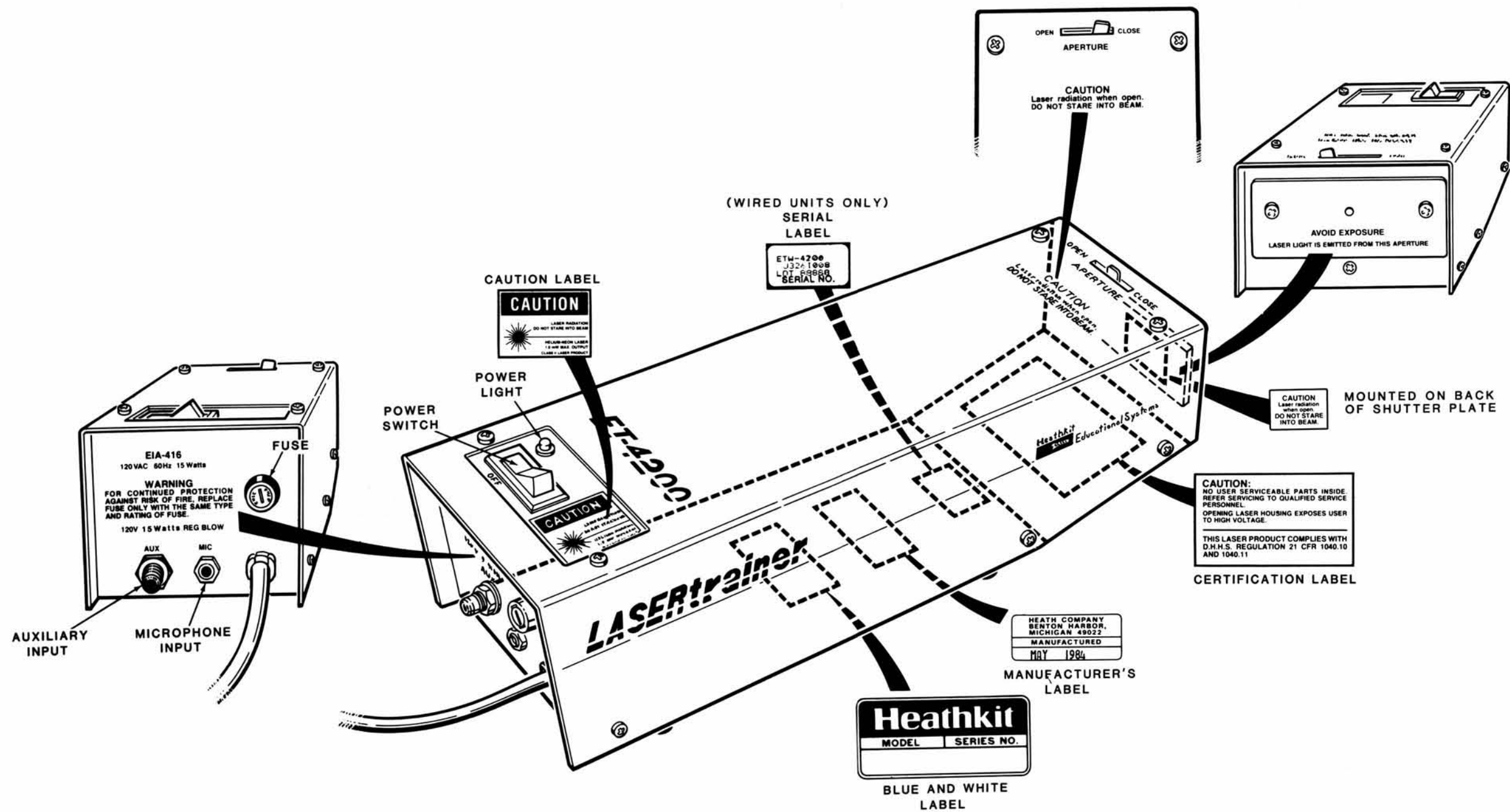
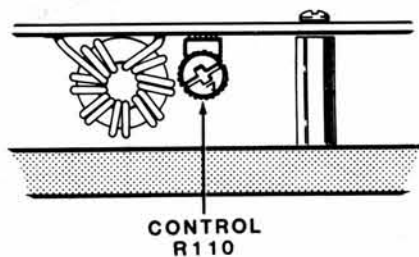
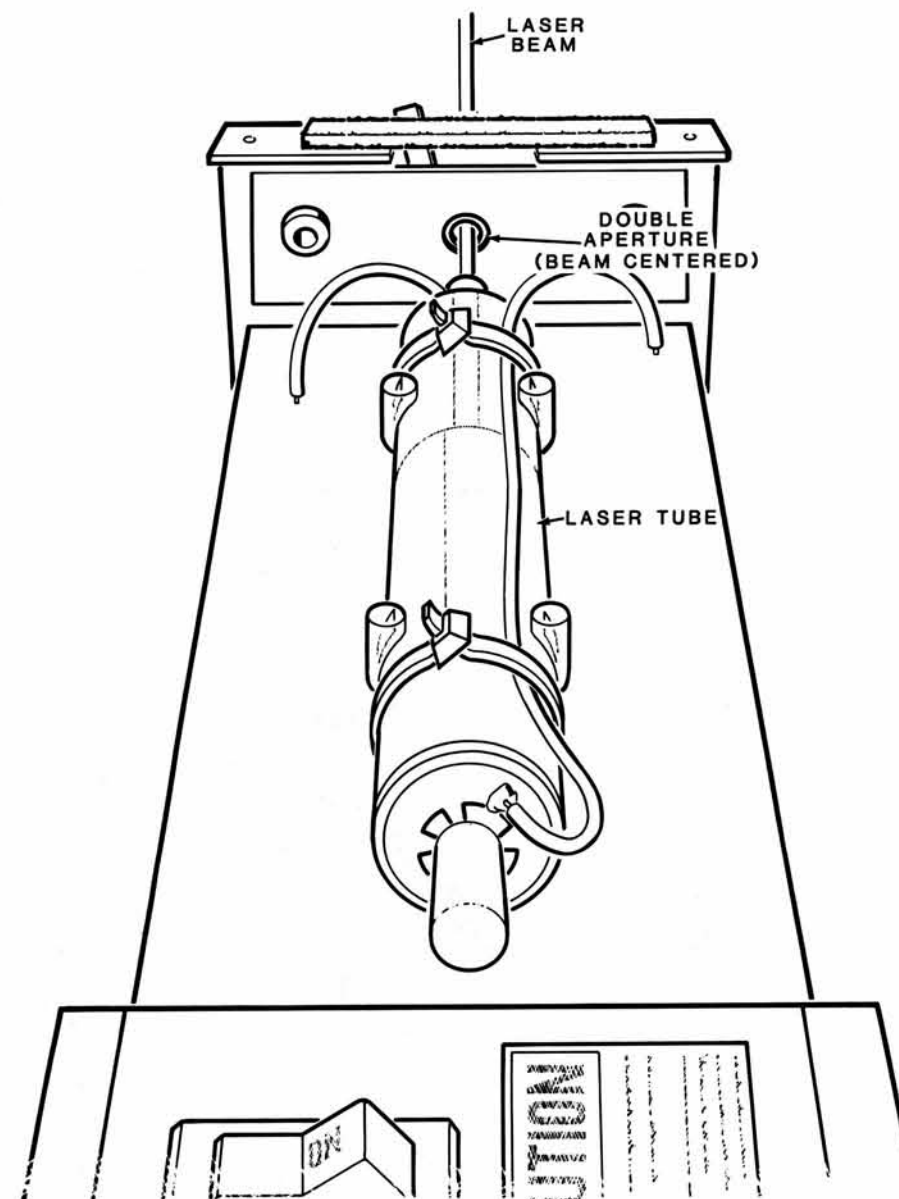

Figure 1



PICTORIAL 2-6



PICTORIAL 2-7

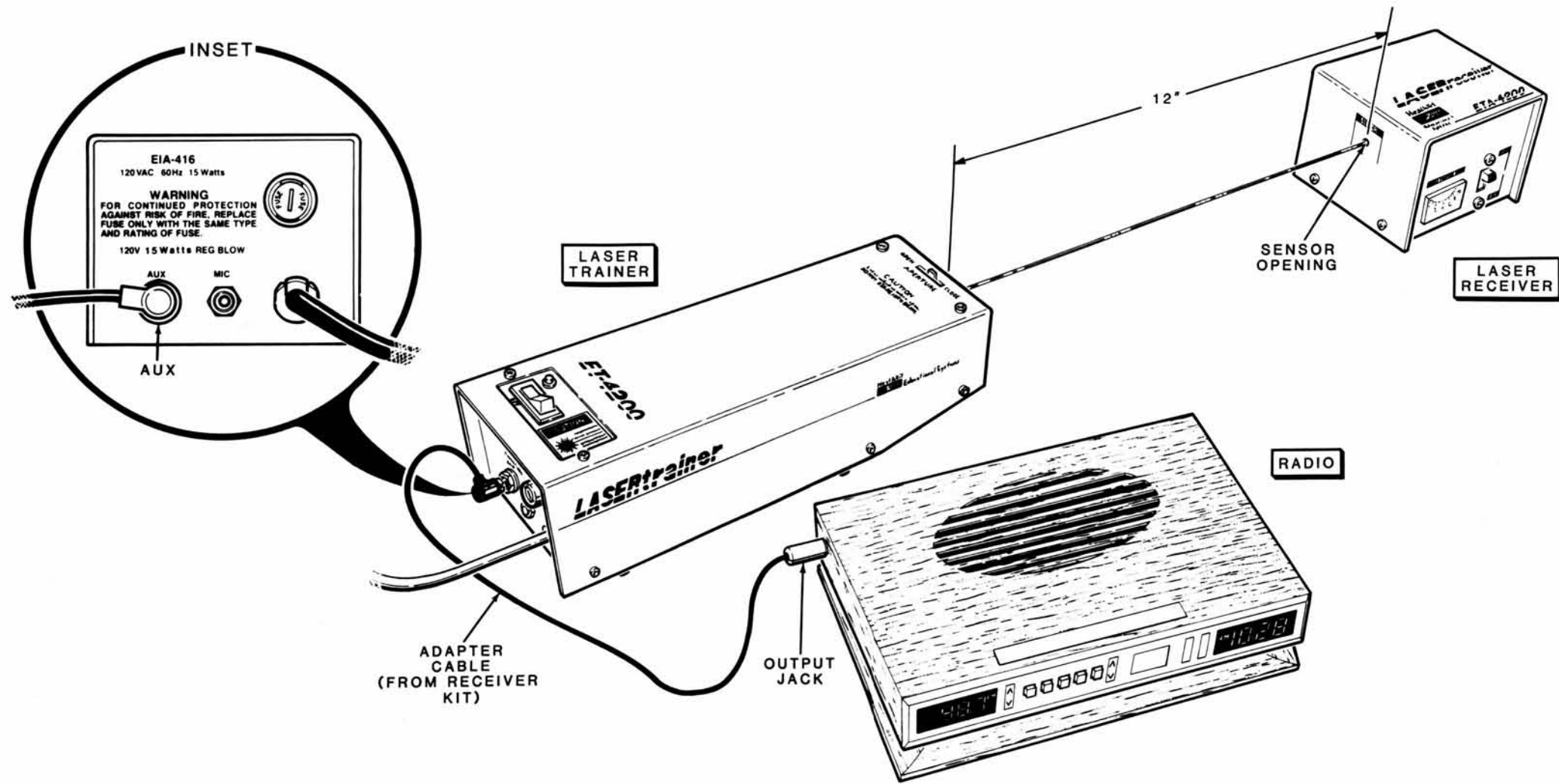

PICTORIAL 2-8

CIRCUIT BOARD X-RAY VIEW

NOTE: To find the PART NUMBER of a component for the purpose of ordering a replacement part:

- A. Find the circuit component number (R5, C3, etc.) on the "X-Ray View."
- B. Locate the same number in the "Circuit Component Number" column of the "Parts List" in the front of this Manual.
- C. Adjacent to the circuit component number, you will find the PART NUMBER and DESCRIPTION which must be supplied when you order a replacement part.

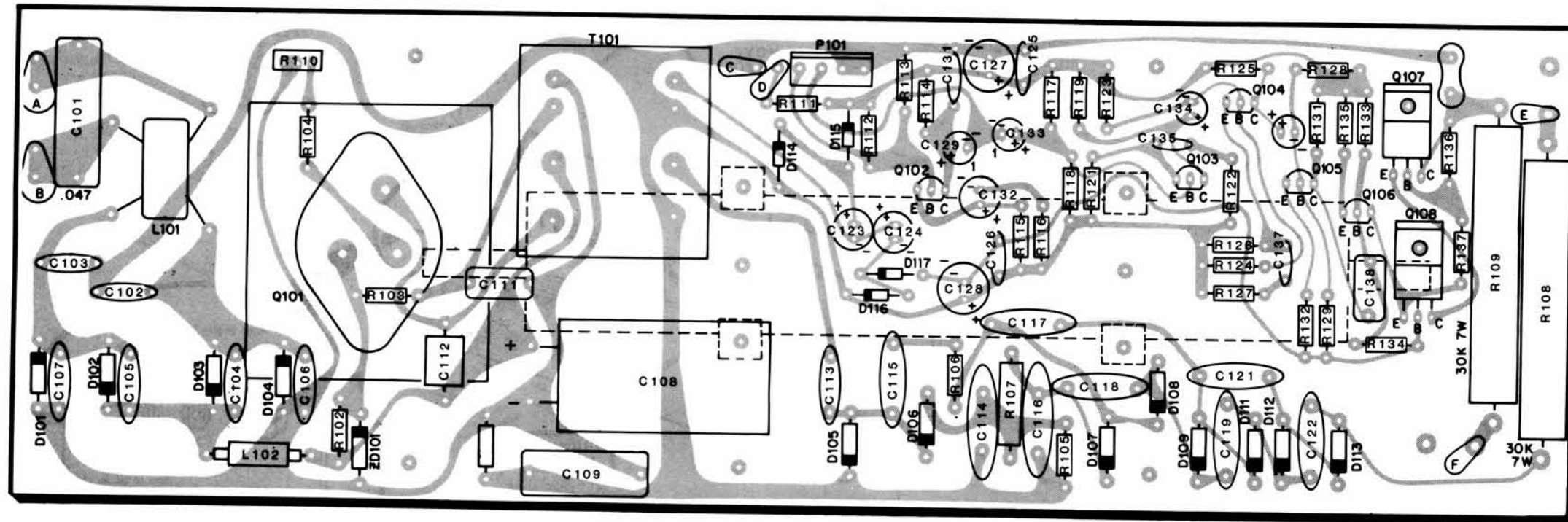





SHOWN FROM COMPONENT SIDE

SCHEMATIC OF THE HEATHKIT® LASER TRAINER MODEL ET/ETW-4200

- NOTES:**
1. REFER TO THE "CIRCUIT BOARD X-RAY VIEW" (ILLUSTRATION BOOKLET PAGE 18) FOR THE PHYSICAL LOCATION OF PARTS.
 2. ALL RESISTORS ARE 1/4-WATT, 5% TOLERANCE UNLESS OTHERWISE SPECIFIED (K=10,000, M=1,000,000).
 3. ALL CAPACITORS LESS THAN 1 ARE IN UF (MICROFARADS), THOSE OF 1 OR GREATER ARE IN pF (PICOFARADS), UNLESS OTHERWISE SPECIFIED.
 4. MEASURED WITH A X100 HIGH-VOLTAGE PROBE TO KEEP CIRCUIT LOADING MINIMAL. NOT TO DO SO MAY DAMAGE THE CIRCUITRY.

5. THE FOLLOWING SYMBOLS ARE USED ON THIS SCHEMATIC DIAGRAM:

-  G2: CIRCUIT BOARD GROUND
-  G1: CHASSIS GROUND
-  A CIRCUIT BOARD WIRE CONNECTION.
-  A DC VOLTAGE READING TAKEN WITH A HIGH INPUT IMPEDANCE VOLTMETER FROM THE POINT INDICATED TO CHASSIS GROUND. VOLTAGES MAY VARY -20%. VOLTAGES WERE MEASURED WITH THE EXT TRIG BUTTON DEPRESSED, ZERO DC OFFSET VOLTAGE, WITH NO EXTERNAL TRIGGER VOLTAGE APPLIED.

SHADED AREAS:

SAFETY-CRITICAL PARTS. USE EXACT REPLACEMENT PARTS FROM HEATH COMPANY ONLY.

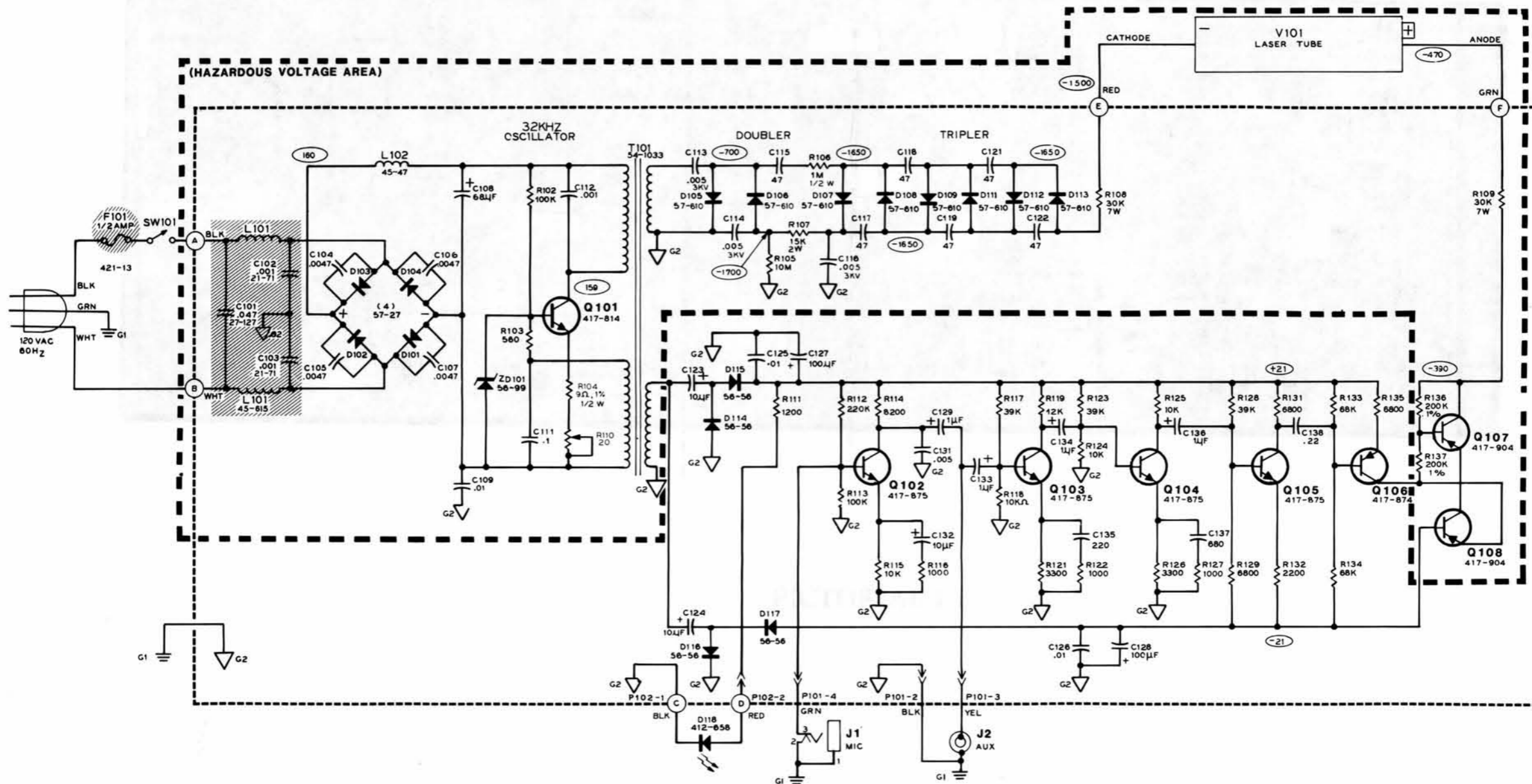

SCHEMATIC DIAGRAM

SECTION 110000 - ELECTRICAL



1. Provide all materials, labor, and equipment necessary for the installation and operation of the lighting system as shown on the drawings.

2. The lighting system shall be installed in accordance with the National Electrical Code (NEC) and all applicable local codes and regulations.

3. The lighting system shall be designed to provide uniform illumination of the work area and to minimize glare and flicker.

4. The lighting system shall be installed in a manner that is safe and secure, and shall be protected from physical damage.

5. The lighting system shall be tested and adjusted to meet the required illumination levels before being accepted for use.

6. The lighting system shall be installed in a manner that is aesthetically pleasing and that complements the overall design of the building.

7. The lighting system shall be installed in a manner that is energy efficient and that meets the requirements of the International Energy Conservation Code (IECC).

8. The lighting system shall be installed in a manner that is easy to maintain and that allows for future expansion.

9. The lighting system shall be installed in a manner that is safe and secure, and shall be protected from physical damage.

10. The lighting system shall be tested and adjusted to meet the required illumination levels before being accepted for use.

MODEL 2015-1011
 FRESH AIR
 CONTROL SYSTEM

SECTION 110000 - ELECTRICAL

- 1. Provide all materials, labor, and equipment necessary for the installation and operation of the lighting system as shown on the drawings.
- 2. The lighting system shall be installed in accordance with the National Electrical Code (NEC) and all applicable local codes and regulations.
- 3. The lighting system shall be designed to provide uniform illumination of the work area and to minimize glare and flicker.
- 4. The lighting system shall be installed in a manner that is safe and secure, and shall be protected from physical damage.
- 5. The lighting system shall be tested and adjusted to meet the required illumination levels before being accepted for use.

