

HEATHKIT[®] MANUAL

for the

LASER TRAINER
Model ET/ETW-4200

595-3317-04

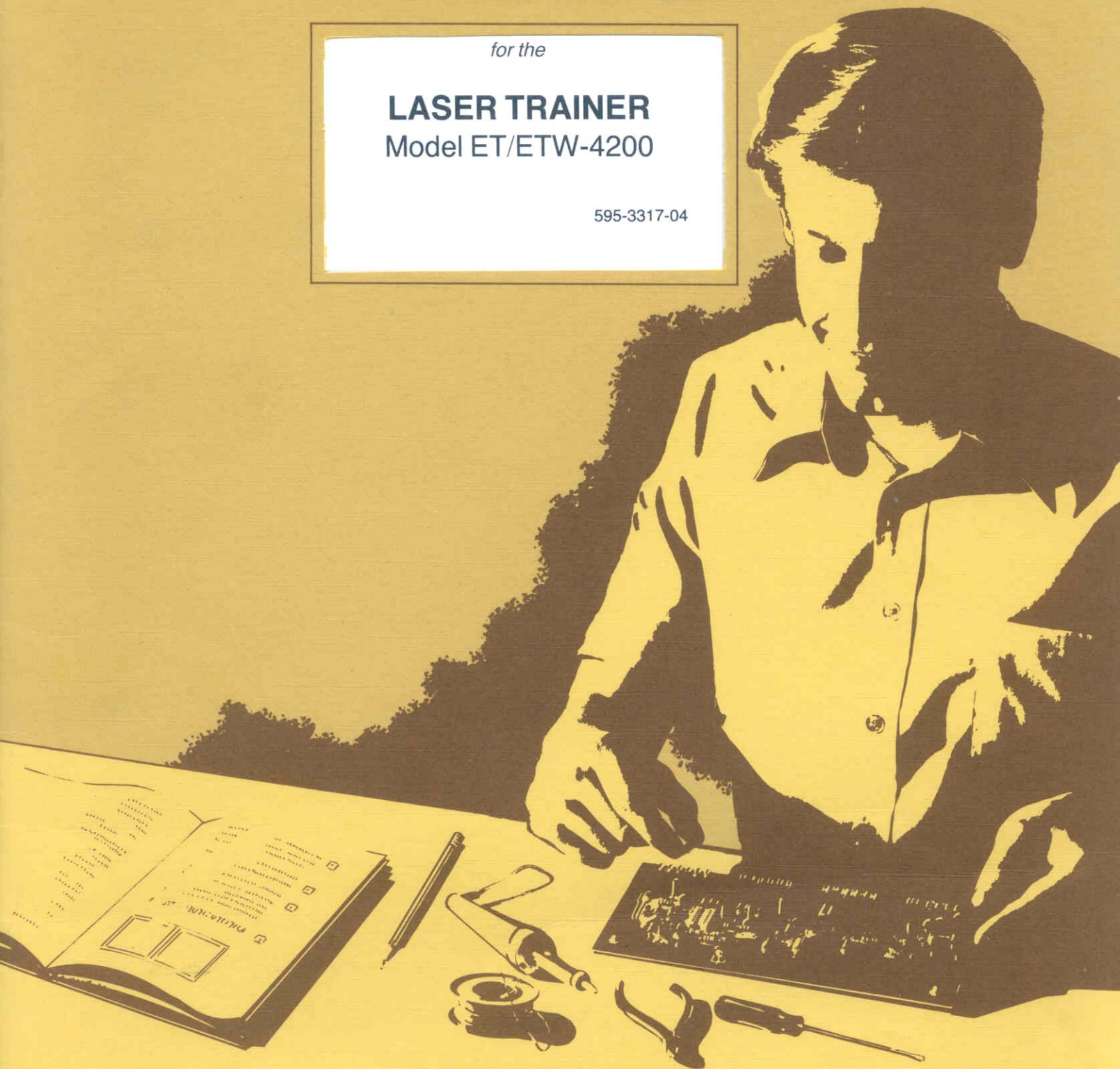

HEATH COMPANY • BENTON HARBOR, MICHIGAN

HEATH COMPANY PHONE DIRECTORY

The following telephone numbers are direct lines to the departments listed:

Kit orders and delivery information (616) 982-3411
Credit (616) 982-3561
Replacement Parts (616) 982-3571

Technical Assistance Phone Numbers

8:00 A.M. to 12 P.M. and 1:00 P.M. to 4:30 P.M., EST, Weekdays Only
Audio (616) 982-3310
Amateur Radio (616) 982-3296
Test Equipment, Weather Instruments and
Home Clocks (616) 982-3315
Television (616) 982-3307
Aircraft, Marine, Security, Scanners, Automotive,
Appliances and General Products (616) 982-3496
Computers — Hardware (616) 982-3309
Computers — Software:
Operating Systems, Languages, Utilities (616) 982-3860
Application Programs (616) 982-3884

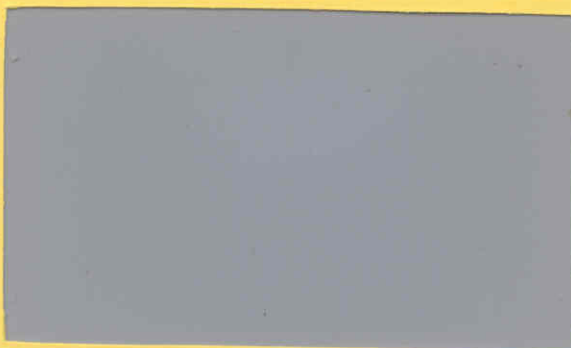

YOUR HEATHKIT 90-DAY LIMITED WARRANTY

Consumer Protection Plan for Heathkit Consumer Products

Welcome to the Heath family. We believe you will enjoy assembling your kit and will be pleased with its performance. Please read this Consumer Protection Plan carefully. It is a "LIMITED WARRANTY" as defined in the U.S. Consumer Product Warranty and Federal Trade Commission Improvement Act. This warranty gives you specific legal rights, and you may also have other rights which vary from state to state.

Heath's Responsibility

PARTS — Replacements for factory defective parts will be supplied free for 90 days from date of purchase. Replacement parts are warranted for the remaining portion of the original warranty period. You can obtain warranty parts direct from Heath Company by writing or telephoning us at (616) 982-3571. And we will pay shipping charges to get those parts to you . . . anywhere in the world.

SERVICE LABOR — For a period of 90 days from the date of purchase, any malfunction caused by defective parts or error in design will be corrected at no charge to you. You must deliver the unit at your expense to the Heath factory, any Heath Zenith Computers and Electronics center (units of Veritechnology Electronics Corporation), or any of our authorized overseas distributors.

TECHNICAL CONSULTATION — You will receive free consultation on any problem you might encounter in the assembly or use of your Heathkit product. Just drop us a line or give us a call. Sorry, we cannot accept collect calls.

NOT COVERED — The correction of assembly errors, adjustments, calibration, and damage due to misuse, abuse, or negligence are not covered by the warranty. Use of corrosive solder and/or the unauthorized modification of the product or of any furnished component will void this warranty in its entirety. This warranty does not include reimbursement for inconvenience, loss of use, customer assembly, set-up time, or unauthorized service.

This warranty covers only Heath products and is not extended to other equipment or components that a customer uses in conjunction with our products.

SUCH REPAIR AND REPLACEMENT SHALL BE THE SOLE REMEDY OF THE CUSTOMER AND THERE SHALL BE NO LIABILITY ON THE PART OF HEATH FOR ANY SPECIAL, INDIRECT, INCIDENTAL OR CONSEQUENTIAL DAMAGES, INCLUDING BUT NOT LIMITED TO ANY LOSS OF BUSINESS OR PROFITS, WHETHER OR NOT FORESEEABLE.

Some states do not allow the exclusion or limitation of incidental or consequential damages, so the above limitation or exclusion may not apply to you.

Owner's Responsibility

EFFECTIVE WARRANTY DATE — Warranty begins on the date of first consumer purchase. You must supply a copy of your proof of purchase when you request warranty service or parts.

ASSEMBLY — Before seeking warranty service, you should complete the assembly by carefully following the manual instructions. Heathkit service agencies cannot complete assembly and adjustments that are customer's responsibility.

ACCESSORY EQUIPMENT — Performance malfunctions involving other non-Heath accessory equipment, (antennas, audio components, computer peripherals and software, etc.) are not covered by this warranty and are the owner's responsibility.

SHIPPING UNITS — Follow the packing instructions published in the assembly manuals. Damage due to inadequate packing cannot be repaired under warranty.

If you are not satisfied with our service (warranty or otherwise) or our products, write directly to our Director of Customer Service, Heath Company, Benton Harbor MI 49022. He will make certain your problems receive immediate, personal attention.

Heathkit® Manual

for the

LASER TRAINER Model ET/ETW-4200

595-3317-04

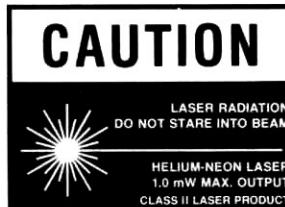

HEATH COMPANY
BENTON HARBOR, MICHIGAN 49022

Copyright © 1985
Heath Company
All Rights Reserved
Printed in the United States of America

TABLE OF CONTENTS

Introduction	3	Circuit Description	33
Assembly Notes	4	Semiconductor Identification Chart	34
Parts List	8	Circuit Board X-Ray View Illustration Booklet, Page 18	
Step-By-Step Assembly	11	Schematic Diagram . Illustration Booklet, Page 19	
Laser Safety	26	Taped Component Chart Illustration Booklet, Page 21	
Laser Beam Adjustment	27	Warranty	Inside front cover
In Case Of Difficulty	29	Customer Service	Inside rear cover
Troubleshooting Chart	31		
Specifications	32		

INTRODUCTION

The Heathkit Model ET-4200 Laser Trainer was designed for the experiments in Heath Continuing Education laser courses, but you can also use it for your own laser experiments. It uses a low-powered helium-neon laser that complies with the Department of Health and Human Services (DHHS), under a Class II classification.

This laser is different from most other lasers in that it can be modulated (at 10% modulation); which means you can add information to the beam by varying the amplitude of the light, and thus varying the beam brightness.

In order to use the modulation feature of the Laser, you will need a detector, such as the Heathkit Laser Receiver, Model ETA-4200. The detector is a photovoltaic converter that can detect the varying brightness when the laser tube is modulated.

There are two input jacks on the rear panel of the Trainer. The MIC jack is for use with a crystal microphone. You can use the AUX jack with any input signal up to 1-volt peak-to-peak, such as a function generator.

This Manual provides all the necessary assembly and checkout information for the kit builder. In addition, basic data is also provided for the wired-product customer; such as, specifications, all the necessary Federal regulations which apply to this product, as well as information that may be required in the future to align the laser beam. All operational information will be provided in Heath's Continuing Education Laser Courses, available separately.

IMPORTANT: If you purchased the wired Laser Trainer, Model ETW-4200, the assembly portions of this Manual do **not** apply directly to your product. At some future time, you may wish to refer to the Parts List, X-Ray View, etc., to order a replacement part; or, you may wish to readjust the beam as described in another section. Make sure you read "Laser Safety" on Page 26. You will find complete operation information in applicable Continuing Education courses available from the Heath Company, especially tailored for use with this instrument.

ASSEMBLY NOTES

TOOLS

You will need these tools to assemble your kit.

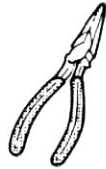

LONG-NOSE
PLIERS



DIAGONAL
CUTTERS



WIRE
STRIPPERS

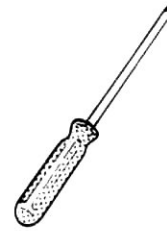

PHILLIPS
SCREWDRIVER

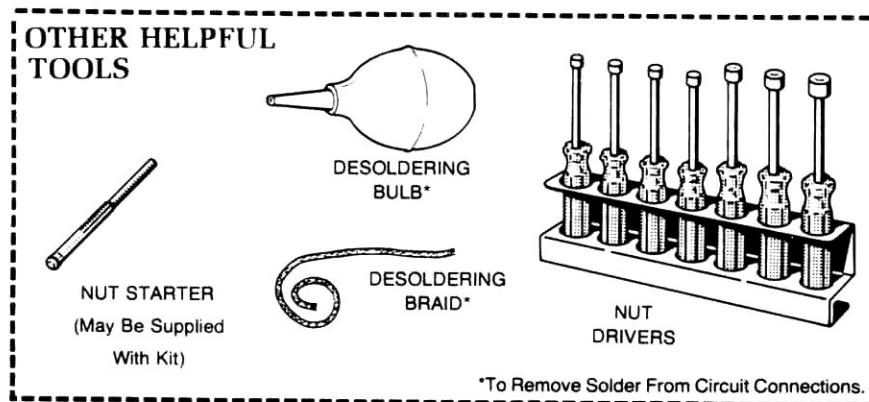

ASSEMBLY

1. Follow the instructions carefully. Read the entire step before you perform each operation.
2. The illustrations in the Manual are called Pictorials and Details. Pictorials show the overall operation for a group of assembly steps; Details generally illustrate a single step. When you are directed to refer to a certain Pictorial "for the following steps," continue using that Pictorial until you are referred to another Pictorial for another group of steps.
3. Most kits use a separate "Illustration Booklet" that contains illustrations (Pictorials, Details, etc.) that are too large for the Assembly Manual. Keep the "Illustration Booklet" with the Assembly Manual. The illustrations in it are arranged in Pictorial number sequence.
4. Position all parts as shown in the Pictorials.
5. Solder a part or a group of parts only when you are instructed to do so.

6. Each circuit part in an electronic kit has its own component number (R2, C4, etc.). Use these numbers when you want to identify the same part in the various sections of the Manual. These numbers, which are especially useful if a part has to be replaced, appear:
- In the Parts List,
 - At the beginning of each step where a component is installed,
 - In some illustrations,
 - In Troubleshooting Charts,
 - In the Schematic,
 - In the sections at the rear of the Manual.
7. When you are instructed to cut something to a particular length, use the scales (rulers) provided at the bottom of the Manual pages.

SAFETY WARNING: Avoid eye injury when you cut off excessive lead lengths. Hold the leads so they cannot fly toward your eyes.

SOLDERING

Soldering is one of the most important operations you will perform while assembling your kit. A good solder connection will form an electrical connection between two parts, such as a component lead and a circuit board foil. A bad solder connection could prevent an otherwise well-assembled kit from operating properly.

It is easy to make a good solder connection if you follow a few simple rules:

1. Use the right type of soldering iron. A 22 to 25-watt pencil soldering iron with a 1/8" or 3/16" chisel or pyramid tip works best.
2. Keep the soldering iron tip clean. Wipe it often on a wet sponge or cloth; then apply solder to the tip to give the entire tip a wet look. This process is called tinning, and it will protect the tip and enable you to make good connections. When solder tends to "ball" or does not stick to the tip, the tip needs to be cleaned and retinned.

NOTE: Always use rosin core, radio-type solder (60:40 tin-lead content) for all of the soldering in this kit. This is the type we have supplied with the parts. The Warranty will be void and we will not service any kit in which acid core solder or paste has been used.

RESISTORS

Resistors are identified in Parts Lists and steps by their resistance value in Ω (ohms), kΩ (kilohms), or MΩ (megohms). They are usually identified by a color code of four or five color bands, where each color represents a number. See the "Resistor Color Code" chart. These colors are given in the steps in their proper order (except for the last band, which indicates a resistor's "tolerance"; see the "Resistor Tolerance Chart"). You do not need to memorize the color codes.

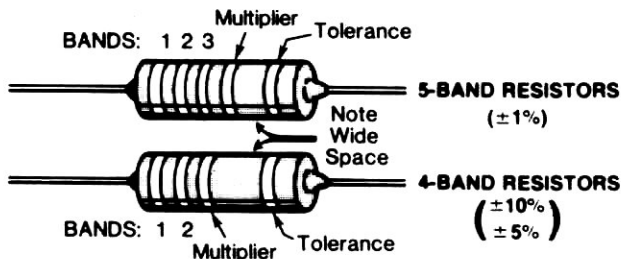

Occasionally, a "precision" or "power" resistor may have the value stamped on it. The letter R, K, or M may also be used at times to signify a decimal point, as in:

2R2 = 2.2 Ω
 2K2 = 2.2 kΩ, or 2200 Ω
 2M2 = 2.2 MΩ

Precision resistors may also be marked as shown in the following examples. The values of the multipliers are shown in the "Multiplier Chart," and the tolerance values are shown in the "Resistor Tolerance" chart.

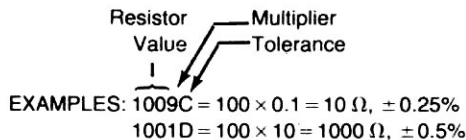

CAPACITORS

Capacitors will be called out by their capacitance value in μF (microfarads) or pF (picofarads) and type: ceramic, Mylar®, electrolytic, etc. Some capacitors may have their value printed in the following manner:

First and second digits of capacitor's value: 15

Multiplier: Multiply the first & second digits by the proper value from the "Multiplier Chart."

To find the tolerance of the capacitor, look up this letter in the capacitor Tolerance chart.

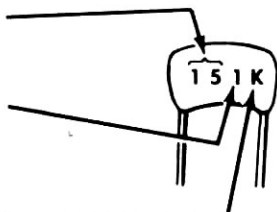

RESISTOR COLOR CODE CHART

	Band 1	Band 2	Band 3 (if used)	Multiplier
Color	1st Digit	2nd Digit	3rd Digit	
Black	0	0	0	1
Brown	1	1	1	10
Red	2	2	2	100
Orange	3	3	3	1,000
Yellow	4	4	4	10,000
Green	5	5	5	100,000
Blue	6	6	6	1,000,000
Violet	7	7	7	10,000,000
Gray	8	8	8	100,000,000
White	9	9	9	—
Silver	—	—	—	.01
Gold	—	—	—	.1

RESISTOR TOLERANCE CHART

	COLOR OR LETTER	
± 10%	SILVER	
± 5%	GOLD	J
± 2%	RED	G
± 1%	BROWN	F
± 0.5%	GREEN	D
± 0.25%	BLUE	C
± 0.1%	VIOLET	B
± 0.05%	GRAY	

MULTIPLIER CHART

FOR THE NUMBER:	MULTIPLY BY:	FOR THE NUMBER:	MULTIPLY BY:
0	1	4	10,000
1	10	5	100,000
2	100	8	0.01
3	1000	9	0.1

CAPACITOR TOLERANCE CHART

LETTER	10 pF OR LESS	OVER 10 pF
B	± 0.1 pF	
C	± 0.25 pF	
D	± 0.5 pF	
F	± 1.0 pF	± 1%
G	± 2.0 pF	± 2%
H		± 3%
J		± 5%
K		± 10%
M		± 20%

EXAMPLES: 151K = 15 × 10 = 150 pF
 759 = 75 × 0.1 = 7.5 pF

NOTE: The letter "R" may be used at times to signify a decimal point, as in: 2R2 = 2.2 (pF or μF).

SPECIAL ASSEMBLY NOTES

NOTE: The following suggestions will not necessarily improve the operation of your kit. They will, however, help you troubleshoot it (if it ever becomes necessary), and help you perform the "Circuit Board Checkout" steps at the end of the assembly sections of this Manual. And you will have a more professionally-built kit when you finish.

1. When you install resistors, always position each resistor so you can read the bands on the resistor in the same direction as you can read the printing on the circuit board (see Figure 1). For resistors that have the value printed on them, instead of color bands, install them so the values are facing away from the circuit board and read in the same direction as the printing on the board.

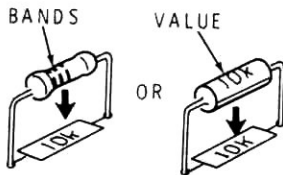

Figure 1

2. When you install ceramic, Mylar, or mica capacitors, always position each capacitor so you can read the value on the capacitor in the same direction as you can read the printing on the circuit board (see Figure 2).

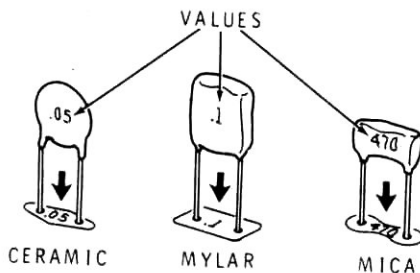

Figure 2

3. When you install electrolytic or other tubular capacitors, always position each capacitor so the value is facing away from the circuit board (see Figure 3). Be sure to observe the correct polarity when you install electrolytic capacitors (as you will be directed in the steps). Other, non-polarized, capacitors should be installed so you can read the values in the same direction as the printing on the circuit board.

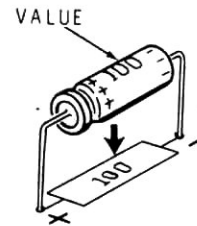

Figure 3

4. Install diodes so the type numbers or part numbers are facing away from the circuit board. Be sure to match the band on one end of each diode with the band mark on the circuit board.

PARTS LIST

Unpack your kit and check each part against the following list. Do not remove any parts from the Taped Components Chart until you use them in a step. If a part is packed in an individual envelope with the part number on it, identify the part, then return it to the envelope until a step calls for it. Do not throw away any packing material until all parts are accounted for.

To order a replacement part, always include the PART NUMBER. Use the Parts Order Form furnished with this kit. If a Parts Order Form is not available, refer to "Replacement Parts" inside the rear cover of this Manual.

TAPED COMPONENTS

NOTE: These parts are taped on a strip which was checked before shipment. Since these parts are taped in the order of assembly, you may not wish to check these parts against the following list.

HEATH Part No.	QTY.	DESCRIPTION	CIRCUIT Comp. No.
-------------------	------	-------------	----------------------

RESISTORS

NOTE: All resistors are 1/4-watt and have a 5% tolerance (fourth band gold) unless designated otherwise. 1% resistors have a brown fifth color band.

6-561-12	1	560 Ω (grn-blu-brn)	R103
6-102-12	3	1000 Ω (brn-blk-red) R127	R116,R122, R127
6-122-12	1	1200 Ω (brn-red-red)	R111
6-222-12	1	2200 Ω (red-red-red)	R132
6-332-12	2	3300 Ω (org-org-red)	R121, R126
6-472-12	1	4700 Ω (yel-viol-red)	R135
6-682-12	2	6800 Ω (blu-gry-red)	R129, R131
6-822-12	1	8200 Ω (gry-red-red)	R114
6-103-12	4	10 kΩ (brn-blk-org)	R115, R118, R124,R125
6-123-12	1	12 kΩ (brn-red-org)	R119
6-393-12	3	39 kΩ (org-wht-org)	R117, R123, R128

HEATH Part No.	QTY.	DESCRIPTION	CIRCUIT Comp. No.
-------------------	------	-------------	----------------------

Resistors (Cont'd.)

6-683-12	2	68 kΩ (blu-gry-org)	R133, R134
6-104-12	2	100 kΩ (brn-blk-yel)	R102, R113
6-2003-12	2	200 kΩ, 1% (red-blk-blk-org)	R136, R137
6-224-12	1	220 kΩ (red-red-yel)	R112
6-105	1	1 MΩ, 1/2 watt (brn-blk-grn)	R106
6-106-12	1	10 MΩ (brn-blk-blu)	R105

DIODES

56-56	4	1N4149	D114, D115, D116, D117
56-99	1	1N5223B zener	ZD101
57-27	4	1N2071	D101, D102, D103, D104

NON-TAPED PARTS

The following parts are not taped on strips. The key numbers correspond to the numbers on the "Parts Pictorial" (Illustration Booklet, Page 1).

KEY No.	HEATH Part No.	QTY.	DESCRIPTION	CIRCUIT Comp. No.	KEY No.	HEATH Part No.	QTY.	DESCRIPTION	CIRCUIT Comp. No.
RESISTORS					Polystyrene				
A1	2-374	1	9Ω, 1%, 1/2-watt	R104	F1	29-50	1	.001 μF (1000)	C112
A2	5-11-2	1	15 kΩ, 2-watt film	R107	Electrolytic				
A3	5-2-7	2	30 kΩ, 7-watt wire-wound	R108, R109	G1	25-900	4	1 μF	C129, C133, C134, C136
CAPACITORS					G1	25-880	3	10 μF	C123, C124, C132
Ceramic					G1	25-948	2	100 μF	C127, C128
B4	21-823	6	47 pF	C115, C117, C118, C119, C121, C122	G2	25-956	1	68 μF	C108
B1	21-22	1	220 pF	C135	TRANSISTORS-LED-DIODE				
B1	21-171	1	680 pF	C137	NOTE: Transistors are marked for identification in one of the following ways:				
B2	21-71	2	.001 μF	C102, C103	1.	Part number.			
B1	21-46	1	.005 μF	C131	2.	Type number.			
B4	21-821	4	.0047 μF	C104, C105, C106, C107	3.	Part number and type number.			
B4	21-70	1	.01 μF	C109	4.	Part number with a type number other than the one listed.			
B3	21-176	2	.01 μF	C125, C126	H1	417-874	1	2N3906 transistor	Q106
B2	21-116	3	.005 μF, 3KV	C113, C114, C116	H1	417-875	4	2N3904 transistor	Q102, Q103, Q104, Q105
Mylar					H2	417-904	2	MPSU60 transistor	Q107, Q108
D1	27-127	1	.047 μF	C101	H3	417-814	1	DTS409 transistor	Q101
D2	27-85	1	.22 μF	C138	H4	412-658	1	Red LED (light-emitting diode)	D118
Polyester					H5	57-610	8	FM50	D105-D109, D111-D113
E1	27-188	1	.1 μF	C111	CHOKES-TRANSFORMER				
* Packaged separately. Do not remove them from their envelopes until they are called for in a step.					J1	45-47	1	2 mH RF choke	L102
					J2	45-615	1	RF choke	L101
					J3	54-1033	1	Power transformer	T101

KEY No.	HEATH Part No.	QTY.	DESCRIPTION	CIRCUIT Comp. No.
---------	----------------	------	-------------	-------------------

CONNECTORS-SOCKETS-PLUG

K1	432-866	2	Small spring connector	
K1	432-753	3	Large spring connector	
K2	432-1279	2	Spade terminal	
K3	432-66	2	Push-on connector	
K4	432-1030	1	2-hole socket shell	
K5	432-954	1	4-hole socket shell	
K6	434-212	1	Phono socket	J2
K7	434-189	1	Transistor socket	
K8	432-827	1	4-pin plug	
K9	436-16	1	Phone jack	J1

FUSEHOLDER-FUSE

L1	423-18	1	Cartridge	
L2	423-17	1	Fuseholder	
L3	423-21	1	Rubber washer	
L4	423-19	1	Plastic nut	
L5	421-13	1	1/2-ampere fuse	F101

HARDWARE

Hardware packets are marked to show the size of the hardware they contain (HDW #4, HDW #6, etc.). You may have to open more than one packet to locate all of the hardware.

#4 Hardware

M1	250-1412	4	4-40 × 3/8" pan head screw
M2	250-1448	1	4-40 × 3/8" flat head screw
M3	253-164	1	#4 spring washer
M4	254-9	2	#4 lockwasher
M5	252-2	2	4-40 nut
M6	252-135	1	4-40 locknut

#6 Hardware

N1	250-1280	6	6-32 × 3/8" pan head screw
N2	250-1307	2	6-32 × 1/4" phillips head screw
N3	250-1434	8	6-32 × 3/8" self-tapping screw
N4	250-1425	2	6-32 × 1/2" screw
N5	254-1	2	#6 lockwasher
N6	252-3	3	6-32 nut
N7	259-1	1	#6 solder lug
N8	255-837	4	6-32 spacer

Other Hardware

P1	253-80	1	Flat washer
P2	253-40	1	#5 flat washer
P3	253-3	4	Fiber washer
P4	254-14	1	1/4" lockwasher
P5	254-4	1	3/8" lockwasher
P6	252-39	1	1/4" nut

KEY No.	HEATH Part No.	QTY.	DESCRIPTION	CIRCUIT Comp. No.
---------	----------------	------	-------------	-------------------

WIRE-SLEEVING

344-125	26"	Small black wire
344-127	12"	Small red wire
344-129	12"	Yellow wire
344-130	12"	Small green wire
344-117	12"	Large black wire
341-6	3-3/4"	Large green wire
344-2	7-1/4"	Medium black wire
346-26	1	7" Clear sleeving

MISCELLANEOUS

Q1	10-1231	1	20 Ω control	R110
Q2	260-700	1	LED grommet	
Q3	260-701	1	LED retainer	
Q4	75-736	1	Strain relief	
Q5	75-738	2	Paper insulator	
Q6	208-6	2	Clip	
Q7	261-43	4	Rubber foot	
Q8	215-658	1	Heat sink	
Q9	61-49	1	Switch	SW101
Q10	73-39	2-1/2"	Foam tape	
Q11	352-31	1	Thermal compound	
Q12	354-7	3	Cable tie	
Q13	204-1200	2	L bracket	
Q14	205-1940	1	Shutter lever	
Q15	205-1942	1	Shutter plate	
Q16	203-2234-2	1	Front panel	
Q17	90-1332-1	1	Cover	
Q18	90-1346-2	1	Chassis	
	85-3052-1	1	Circuit board	
	89-54	1	Line cord	
Q19	411-871	1	Laser tube	V101
Q20	490-109	1	Alignment tool	

LABELS-PRINTED MATERIAL (Inside manual cover)

R1		1	Blue and white label
R2	390-1192	1	Manufacturer's label
R3	390-2667	1	Certification label
R4	390-2666	1	Radiation label
R5	390-2816	1	Small "Caution" label
	597-260	1	Parts Order Form
		1	Assembly Manual (See Page 1 for the part number.)
			Solder

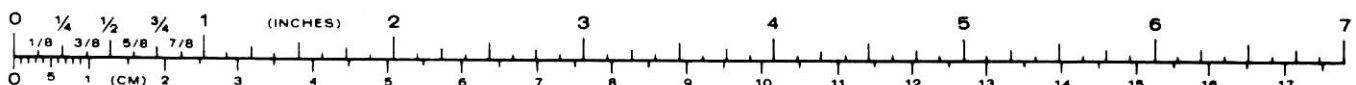

STEP-BY-STEP ASSEMBLY

CIRCUIT BOARD ASSEMBLY

Refer to Pictorial 1-1 (Illustration Booklet, Page 3) as you read the following notes and steps.

NOTES:

1. Many circuit board drawings, such as the one shown in Pictorial 1-1, are divided into two or more sections. These sections show you which area of the circuit board you are working in for a specific series of steps.
2. Each series of steps has you installing parts in a top-to-bottom, left-to-right sequence. Occasionally, you may be directed to install a particular component in an area out of sequence. These components are each identified in the step and on the Pictorial with a special callout.
3. Check off each step as you perform it. You may also wish to place a check mark near each component on the Pictorial as you install it.
4. In general, solder instructions are given only at the end of a series of similar steps. You may solder more often, if you desire.

NOTES:

1. Cut the "Taped Component Chart" from the **back** of the "Illustration Booklet," along the dotted lines.
2. Refer to the "Taped Component Chart" before you begin.

In the following steps, you will be given detailed instructions on how to install and solder the first part on the circuit board. Read and perform each step carefully. Then use the same procedure whenever you install parts on a circuit board.

Note that one side of the circuit board has component outlines shown on it. This side of the circuit board is referred to as the "component side."

- () Position the circuit board as shown in the Pictorial with the component side up. Always install components on the component side of the circuit board, and solder the leads to the foil on the other side unless a step specifically directs you otherwise.
- () Hold a 560 Ω (grn-blu-brn) resistor as shown and bend the leads straight down to fit the hole spacing on the circuit board.

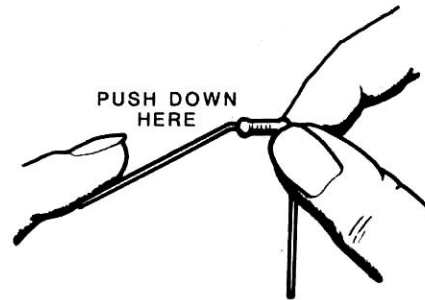

- () R103: Start the leads into the holes at the resistor's location near the center of Section 1 of the circuit board. The end with color bands may be positioned either way. NOTE: Resistors are identified by the following outline:

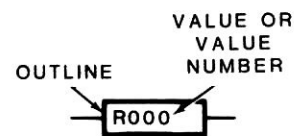

- () Press the resistor against the circuit board. Then bend the leads outward slightly to hold it in place.



() Solder the resistor leads to the circuit board as follows:

1. Push the soldering iron tip against both the lead and the circuit board foil. Heat **both** for two or three seconds.

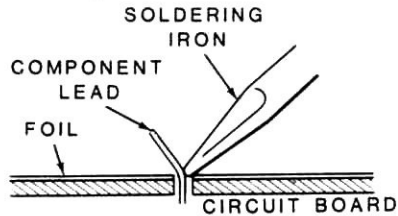

2. Then apply solder to the other side of the connection. **IMPORTANT:** Let the heated lead and the circuit board foil melt the solder.

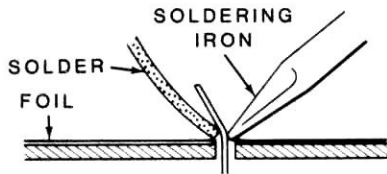

3. As the solder begins to melt, allow it to flow around the connection. Then remove the solder and the iron and let the connection cool.

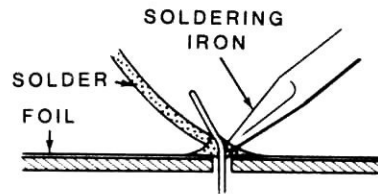

- () Cut off the excess lead lengths close to the connection. **WARNING:** Clip the leads so the ends will not fly toward your eyes.
- () Check each connection. Compare it to the illustrations on Page 13. After you have checked the solder connections, proceed with the assembly on Page 14. Use the same soldering procedure for each connection.

A GOOD SOLDER CONNECTION

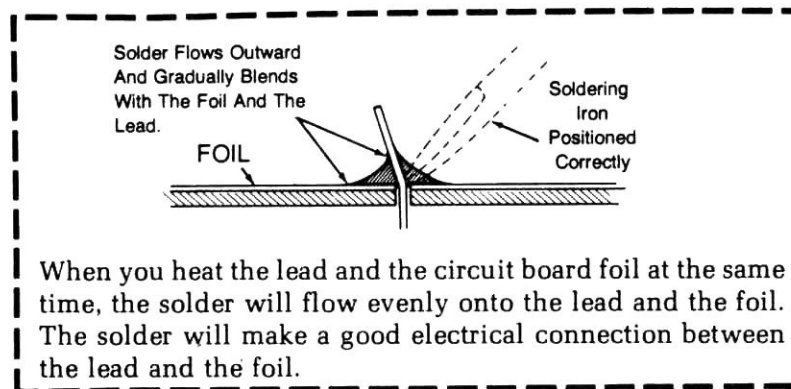

POOR SOLDER CONNECTIONS

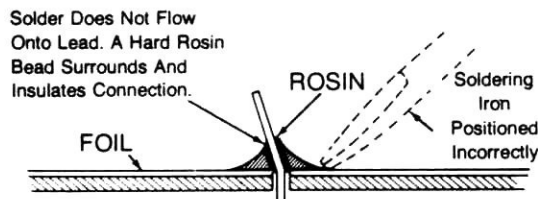

When the lead is not heated sufficiently, the solder will not flow onto the lead as shown above. To correct, reheat the connection and, if necessary, apply a small amount of additional solder to obtain a good connection.

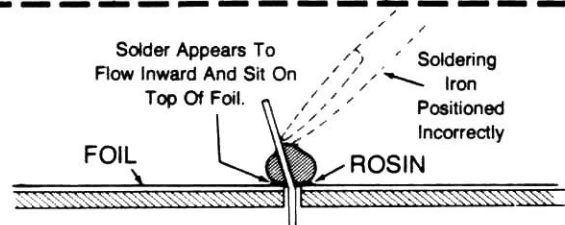

When the foil is not heated sufficiently the solder will blob on the circuit board as shown above. To correct, reheat the connection and, if necessary, apply a small amount of additional solder to obtain a good connection.

SOLDER BRIDGES

A solder bridge between two adjacent foils is shown in photograph A. Photograph B shows how the connection should appear. A solder bridge may occur if you accidentally touch an adjacent previously soldered connection, if you use too much solder, or if you "drag" the soldering iron across other foils as you remove it from the connection. A good rule to follow is: always take a good look at the foil area around each lead before you solder it. Then, when you solder the connection, make sure the solder remains in this area and does not bridge to another foil. This is especially important when the foils are small and close together. NOTE: It is alright for solder to bridge two connections on the same foil.

Use only enough solder to make a good connection, and lift the soldering iron straight up from the circuit board. If a solder bridge should develop, turn the circuit board foil-side-down and heat the solder between connections. The excess solder will run onto the tip of the soldering iron, and this will remove the solder bridge. NOTE: The foil side of most circuit boards has a coating on it called "solder resist." This is a protective insulation to help prevent solder bridges.

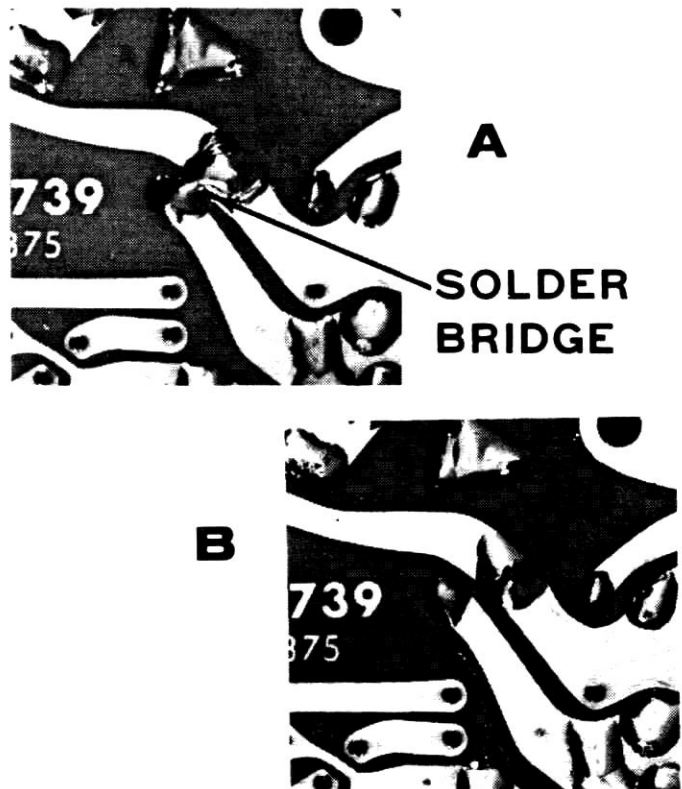

Section 1

Start at the top of Section 1 and install the following components. The sequence of the steps matches the locations of the components on the circuit board.
NOTE: Make sure you installed 560 Ω resistor R103 in an earlier step.

NOTE: When you install a diode, match the banded end of the diode with the band mark on the circuit board. A diode will not work properly if it is installed backwards.

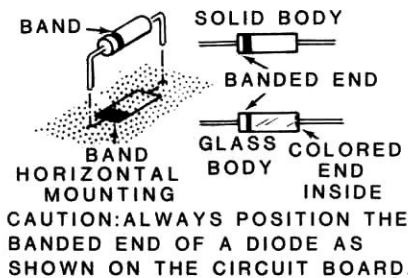

- () D101: 1N2071 diode (#57-27). NOTE: This diode is identified on the board by the following outline.

CAUTION: ALWAYS POSITION THE BANDED END OF A DIODE AS SHOWN ON THE CIRCUIT BOARD.



- () D102: 1N2071 diode (#57-27).
 () D103: 1N2071 diode (#57-27).
 () D104: 1N2071 diode (#57-27).
 () R102: 100 k Ω (brn-blk-yel).
 () ZD101: 1N5223B zener diode (#56-99).
 () Solder the leads to the foil and cut off the excess lead lengths.

Section 2

- () R111: 1200 Ω (brn-red-red).
 () R113: 100 k Ω (brn-blk-yel).
 () R114: 8200 Ω (gry-red-red).
 () R117: 39 k Ω (org-wht-org).
 () R119: 12 k Ω (brn-red-org).
 () R123: 39 k Ω (org-wht-org).
 () D114: 1N4149 diode (#56-56).
 () D115: 1N4149 diode (#56-56).
 () R112: 220 k Ω (red-red-yel).
 () R118: 10 k Ω (brn-blk-org).
 () R121: 3300 Ω (org-org-red).
 () R115: 10 k Ω (brn-blk-org).
 () R116: 1000 Ω (brn-blk-red).
 () D117: 1N4149 diode (#56-56).
 () D116: 1N4149 diode (#56-56).
 () R106: 1 M Ω , 1/2-watt (brn-blk-grn).

NOTE: The following four components are **not** on tape strips.

- () R107: 15 k Ω , 2-watt. Position this resistor 1/4" above the surface of the circuit board. The circuit board may be screened "15K 1W."
 () D106: FM50 diode (#57-610).
 () D105: FM50 diode (#57-610).
 () D107: FM50 diode (#57-610).
 () R105: 10 M Ω (brn-blk-blu).
 () Solder the leads to the foil and cut off the excess lead lengths.

Section 3

- () R125: 10 k Ω (brn-blk-org).
- () R128: 39 k Ω (org-wht-org).
- () R131: 6800 Ω (blu-gry-red).
- () R135: 4700 Ω (yel-viol-red).
- () R133: 68 k Ω (blu-gry-org).
- () R136: 200 k Ω , 1% (red-blk-blk-org).
- () R122: 1000 Ω (brn-blk-red). NOTE: The circuit board may be screened "1K."
- () R126: 3300 Ω (org-org-red).
- () R124: 10 k Ω (brn-blk-org).
- () R127: 1000 Ω (brn-blk-red). NOTE: The circuit board may be screened "1K."
- () R137: 200 k Ω , 1% (red-blk-blk-org).
- () R132: 2200 Ω (red-red-red).
- () R129: 6800 Ω (blu-gry-red).
- () R134: 68 k Ω (blu-gry-org).
- NOTE: This completes the installation of parts from your Taped Component Chart.
- () D108: FM50 diode (#57-610).
- () D109: FM50 diode (#57-610).
- () D111: FM50 diode (#57-610).
- () D112: FM50 diode (#57-610).
- () D113: FM50 diode (#57-610).
- () R109: 30 k Ω , 7-watt wire-wound.
- () R108: 30 k Ω , 7-watt wire-wound. NOTE: Cut a 2-1/4" length of clear sleeving and place it over the resistor before you install it.
- () R104: (In Section 1) 9 Ω , 1%, 1/2-watt resistor. NOTE: The circuit board may be screened "6.8."
- () Solder the leads to the foil and cut off the excess lead lengths.

Refer to Pictorial 1-2 (Illustration Booklet, Page 4) for the following steps.

NOTE: When you install the following transistors, be sure to match the flat on the transistor with the flat on the circuit board outline. Position the transistor 1/4" above the board, solder the leads to the foil, and cut off the excess lead lengths.

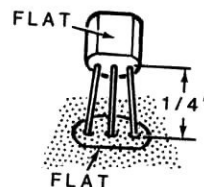

- () Q104: 2N3904 transistor (#417-875).
- () Q102: 2N3904 transistor (#417-875).
- () Q103: 2N3904 transistor (#417-875).
- () Q105: 2N3904 transistor (#417-875).
- () Q106: 2N3906 transistor (#417-874).



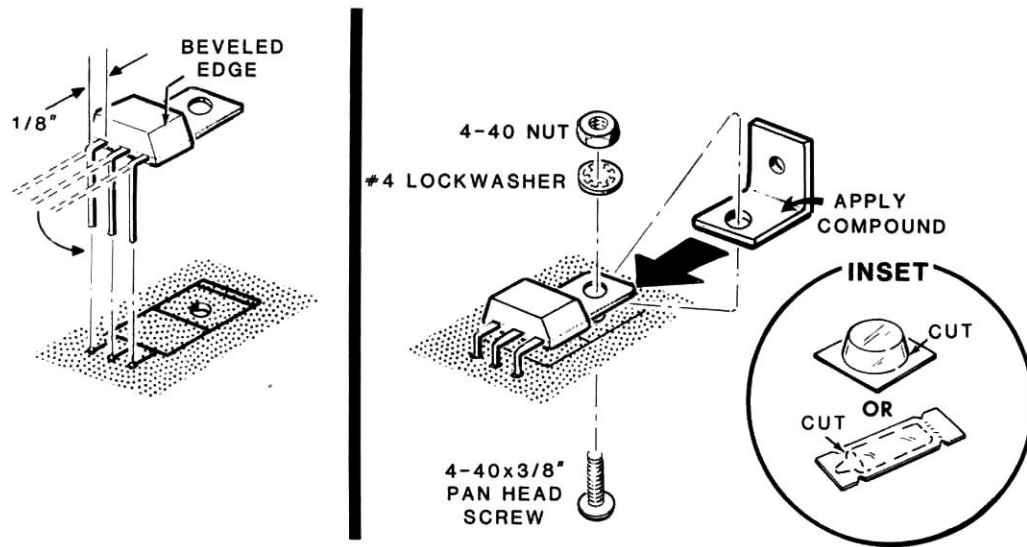

Detail 1-2A

Refer to Detail 1-2A for the following steps.

- () Q107: MPSU60 transistor (#417-904). Position the transistor so the beveled edge is as shown. Then bend the leads at a 90° angle 1/8" from the body of the transistor using long-nose pliers. Insert the leads into the board at Q107. Do not solder the leads at this time.

WARNING: The thermal compound you will use in the following steps helps transfer heat from the transistor to the heat sink. The compound is not caustic, but make sure you do not get it into your eyes, ears, nose, mouth, or on your clothing. Always wash your hands after you use the compound. Keep this and all chemicals out of the reach of children.

- () Locate the container of thermal compound and cut off one corner as shown in the inset drawing. Now position an L bracket so the larger hole is as shown and apply a layer of compound on the bracket. Insert the L bracket under the metal portion of the transistor that you installed earlier. Fasten the bracket and transistor to the board with a 4-40 × 3/8" pan head screw, #4 lockwasher, and a 4-40 nut.
- () Solder the leads of the transistor to the foil and cut off the excess lead lengths.
- () Q108: In the same manner, install the other MPSU60 transistor (#417-904) at Q108.

Set the thermal compound aside; it will be used later.

Heathkit®

Refer to Pictorial 1-3 (Illustration Booklet, Page 5) for the following steps.

- () Mount a spade terminal at location A and one at location B on the circuit board. Solder both terminals to the circuit board foil.

NOTE: In some of the following steps, you will install disc-type ceramic capacitors. When you install these capacitors, do not push the insulated portion of the leads into the holes. This could make it difficult to solder the leads to the foil.

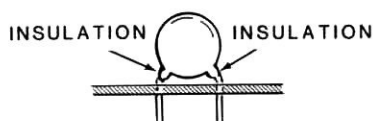

- () C103: .001 μ F ceramic.
- () C102: .001 μ F ceramic.
- () C111: .1 μ F polyester.
- () C112: .001 μ F (1000) polystyrene. Disregard any other marking on the capacitor.
- () L102: 2 mH RF choke (#45-47).
- () Solder the leads to the foil and cut off the excess lead lengths.

Section 2

- () P101: 4-pin plug. When you install this plug, position the tab side over the double outline on the board. Solder the pins to the foil.

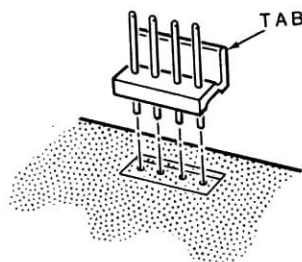

- () C131: .005 μ F ceramic. NOTE: This is the smallest of the .005 μ F capacitors.

NOTE: Before you install an electrolytic capacitor, look at it and identify the leads. One lead will have either a negative (-) mark or a positive (+) mark near it on the side of the capacitor. (The marking for a negative lead may look like an oblong bar, sometimes with a circle around it, inside an arrow.) . . . Be sure to install the negative lead in the negative-marked hole, and the positive lead in the positive-marked hole.

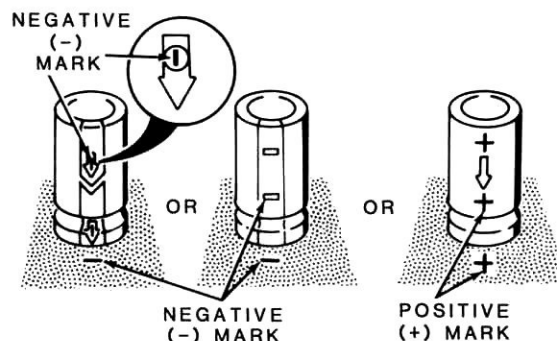

Electrolytic capacitors are identified on the circuit board by the following outline.



- () C127: 100 μ F electrolytic.
- () C125: .01 μ F ceramic.
- () C133: 1 μ F electrolytic.
- () C129: 1 μ F electrolytic.
- () C132: 10 μ F electrolytic.
- () C123: 10 μ F electrolytic.
- () C124: 10 μ F electrolytic.
- () C126: .01 μ F ceramic.
- () C128: 100 μ F electrolytic.
- () Solder the leads to the foil and cut off the excess lead lengths.

Section 3

- () C134: 1 μ F electrolytic.
- () C136: 1 μ F electrolytic.
- () C135: 220 pF ceramic.
- () C137: 680 pF ceramic.
- () C138: .22 μ F Mylar.
- () Solder the leads to the foil and cut off the excess lead lengths.

Refer to Pictorial 1-4 (Illustration Booklet, Page 6) for the following steps.

Section 1

- () C101: .047 μ F Mylar.
- () R110: 20 Ω control (#10-1231). Position the rotating face of this control toward the **edge** of the board.

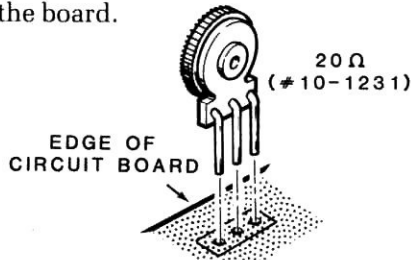

- () Form the leads of the RF choke (#45-615) as shown in the inset drawing on Pictorial 1-4.
- () Cut the leads of the RF choke 1/2" from the body as shown. Then remove 1/4" of insulation from each of the lead ends.

NOTE: In the next step, when you install the RF choke, it is not necessary to position the choke directly over the outline on the circuit board.

- () L101: RF choke. Solder the leads to the foil and cut off the excess lead lengths.

NOTE: The next five components are separately packaged in (2) coin envelopes.

- () C107: .0047 μ F ceramic (#21-821).
- () C105: .0047 μ F ceramic (#21-821).

- () C104: .0047 μ F ceramic (#21-821).
- () C106: .0047 μ F ceramic (#21-821).
- () C109: .01 μ F ceramic (#21-70). NOTE: The circuit board may be marked ".68."
- () Solder the leads to the foil and cut off the excess lead lengths.

Section 2

- () C118: 47 pF ceramic.
- () C113: .005 μ F, 3KV ceramic.
- () C115: 47 pF ceramic.
- () C114: .005 μ F, 3KV ceramic. NOTE: The circuit board may be marked ".02."
- () C116: .005 μ F, 3KV ceramic. NOTE: The circuit board may be marked ".02."
- () C117: 47 pF ceramic.
- () C121: 47 pF ceramic.
- () C119: 47 pF ceramic.
- () C122: 47 pF ceramic.
- () Solder the leads to the foil and cut off the excess lead lengths.

Refer to Pictorial 1-5 (Illustration Booklet, Page 7) for the following steps.

- () Refer to Detail 1-5A and insert the transistor socket lugs into their respective holes in the circuit board at Q101. Make sure the lugs are fully seated into the circuit board holes; then solder the lugs to the foil.
- () Place two fiber washers on the transistor socket as shown.
- () Locate the thermal compound and apply a layer on the lead side of the DTS409 transistor (#417-814).
- () Place the heat sink on the transistor socket so the two end holes line up with the holes in the socket. Make sure the fiber washers are still on the socket.

- () Position the transistor so the wider space from the leads to the hole is as shown and insert the transistor leads into the socket. Secure the transistor to the socket with two 6-32 × 1/2" screws. Do not overtighten these screws. NOTE: You may have to bend nearby .005 μF capacitor C106 slightly out of the way of the heat sink.

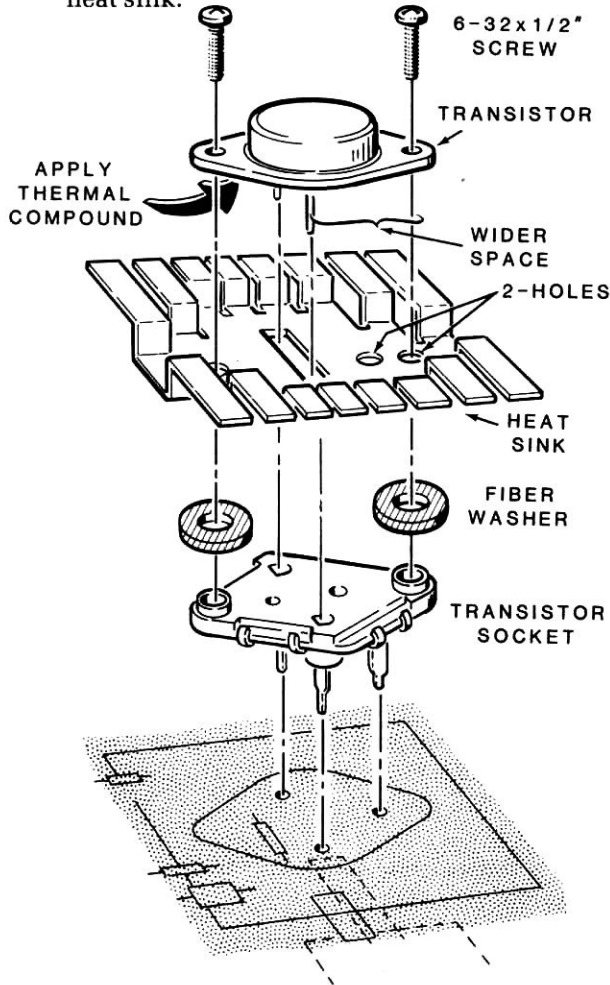

Detail 1-5A

- () T101: Mount the power transformer (#54-1033) at T101 on the circuit board; solder the leads to the foil.
- () C108: 68 μF electrolytic. Note the position of the negative (-) lead and bend both leads at a 90° angle as shown. Install the capacitor on the circuit board and secure it with a cable tie as shown at the top of the next column. Then solder the leads to the foil, and cut off the excess lead lengths.

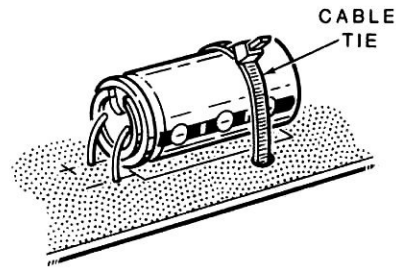

NOTE: When you are directed to "prepare a wire" as in the following steps, cut the wire to the indicated length and remove 1/4" of insulation from each wire end. Tightly twist together the bare wire ends and add a small amount of solder to hold the fine wire strands together.

- () Cut and prepare a 12" small red wire and a 12" small black wire.
- () Cut 1/8" from one end of the red and the black wires. Then crimp and solder a **small** spring connector on this end of each wire as shown in inset drawing #1 on the Pictorial.

In the following steps, you will insert the connectors on these wires into a 2-hole socket shell. Be sure to position the socket with the slotted side up, and the connectors with the small locking tab up, when you insert them. See inset drawing #2.

- () Black wire in hole 1.
- () Red wire in hole 2.
- () Loosely twist together the entire length of these wires, except the ends.
- () Install the black wire in hole C and the red wire in hole D. Solder the wires to the foil and cut off the excess wire lengths.
- () Prepare both ends of a 10" large black and a 3-3/4" large green wire. NOTE: Use solder sparingly to hold the fine wire strands together.

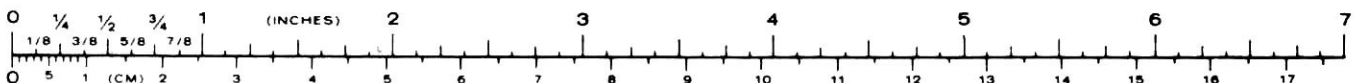

- () Connect and solder one end of the black wire in hole E and cut off the excess wire from the foil side. Route the other end of the wire through the larger hole near E. Form a 1/2"-high loop in the wire above the board.
- () Connect and solder one end of the green wire in hole F and cut off the excess wire from the foil side. Route the other end of the wire through the larger hole near F. Form a 1/2"-high loop as before.
- () Remove the backing from one of the paper insulators. Press the insulator on the board next to holes AA, AB, and AC. Do not cover the holes. NOTE: Only a portion of the insulating paper, next to the holes, will stick to the board.
- () Similarly install the other piece of insulating paper next to holes AD, AE, and AF.
- () Mount a clip at AB and one at AE with 6-32 × 3/8" pan head screws, #6 lockwashers, and 6-32 nuts.

CIRCUIT BOARD CHECKOUT

Carefully inspect the foil side of the circuit board for the following most-commonly-made errors.

- () Unsoldered connections.
- () Poor solder connections.
- () Solder bridges between foil patterns.
- () Protruding leads which could touch together or touch the chassis when the circuit board is installed later.

Refer to the illustrations where parts are installed as you make the following visual checks:

- () Electrolytic capacitors for the correct position of the positive (+) or negative (-) marked lead.
- () Diodes for the proper type and installation.
- () Transistors for the proper type and installation.

Refer to Pictorial 1-6 (Illustration Booklet, Page 8) for the following steps.

- () Position the circuit board foil side up as shown.

- () Cut four 1-1/8" lengths of clear sleeving. Install two lengths of sleeving on each clip.

Refer to Pictorial 1-7 (Illustration Booklet, Page 8) for the following steps.

WARNING: Be careful when you handle the laser tube. Do not strike, scratch, or subject the tube to more than moderate pressure at any time. Any of these could damage the tube.

- () Carefully unpack the laser tube.
- () V101: Place the tube over the two mounting clips so it is centered between them, and the end with the plastic cap and covered pin is as shown. Slightly spread one clip and carefully push that end of the tube down into the clip. Do the same with the other clip at the other end of the tube.
- () Wrap the black wire around the solder lug on the indicated end of the tube and solder it.
- () Similarly connect and solder the green wire to the solder lug at the other end of the tube.
- () Secure the black wire to the tube with two cable ties as shown in the inset drawing.
- () Remove the indicated plastic cap from the laser tube. Do not touch this end of the tube with your fingers.

This completes the circuit board assembly. Set it aside temporarily.



Heathkit®

CHASSIS ASSEMBLY

Parts Mounting

Refer to Pictorial 2-1 (Illustration Booklet, Page 9) for the following steps.

- () Position the chassis as shown.
- () Using the dimensions shown on the Pictorial, install the four rubber feet by first removing the paper backing and the rubber trim edges from each foot, and then pressing it firmly onto the chassis.

Remove the paper backing from each of the following labels and install the labels approximately at the locations shown.

- () Certification label (#390-2667).
- () Manufacturer's label (#390-1192).
- () Blue and white label. NOTE: Be sure to refer to the Model and Series numbers on the blue and white label in any correspondence you have with the Heath Company about your Laser Trainer.

Refer to Pictorial 2-2 (Illustration Booklet, Page 10) for the following steps.

- () Position the chassis as shown.
- () Remove the paper backing from the radiation label and install it on the chassis at the location shown. Be sure to center it carefully over the openings in the chassis.

- () J2: Refer to Detail 2-2A and install the phono socket at J2 with the hardware that came with the socket, also use a 3/8" lockwasher. NOTE: Before you install the socket, bend the end of the solder lug up at a 45° angle. Position the solder lug as shown as you tighten the nut securely.

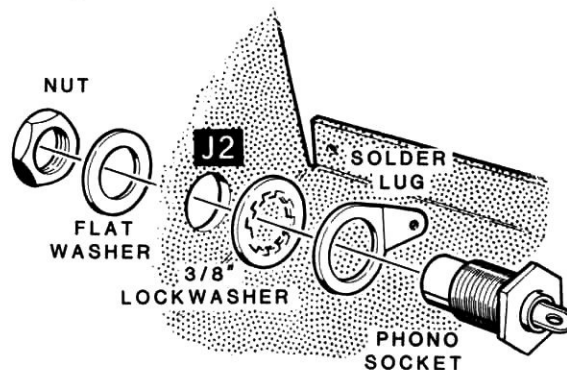

Detail 2-2A

- () J1: Refer to Detail 2-2B and position the phone jack as shown. Then mount it at J1 with a 1/4" lockwasher and 1/4" nut. Make sure the nut is tightened securely.

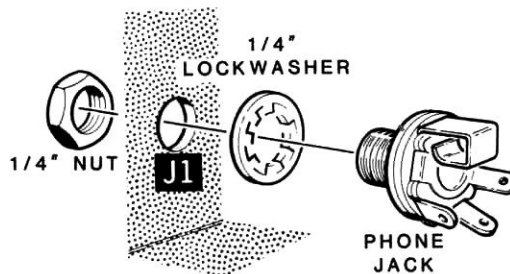

Detail 2-2B

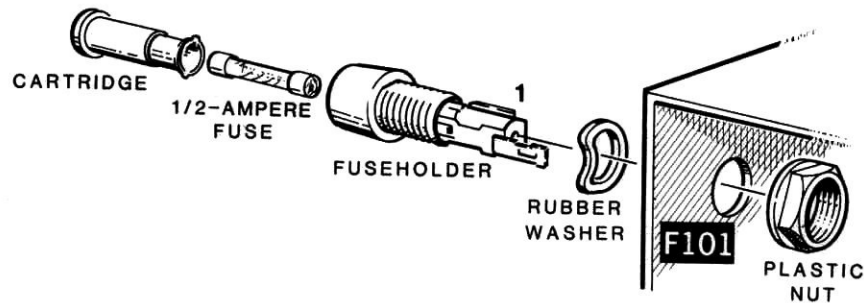

Detail 2-2C

- () Refer to Detail 2-2C and place the rubber washer onto the fuseholder. Position the fuseholder so that lug 1 is as shown and insert the holder at F101. Secure the fuseholder with a plastic nut. Then bend lug 1 of the fuseholder out at a 45° angle.
- () F101: Insert the 1/2-ampere fuse into the cartridge and install the cartridge into the holder. Use a screwdriver, and as you push in, turn the cartridge 1/8 turn clockwise.
- () SW101: Refer to Detail 2-2D and position the switch so the ON position is as shown. Push the switch in until it snaps into place.
- () D118: Refer to Detail 2-2E and insert the LED grommet into hole D118. Position the LED so the long lead is toward the edge of the chassis as shown, and insert the LED into the grommet as far as it will go until it snaps in place and cannot be easily pulled out. Then push the LED retainer all the way onto the rear of the grommet.

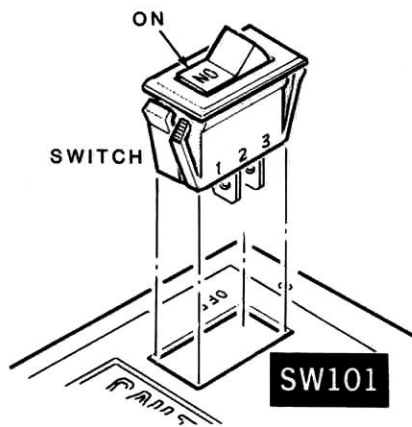

Detail 2-2D

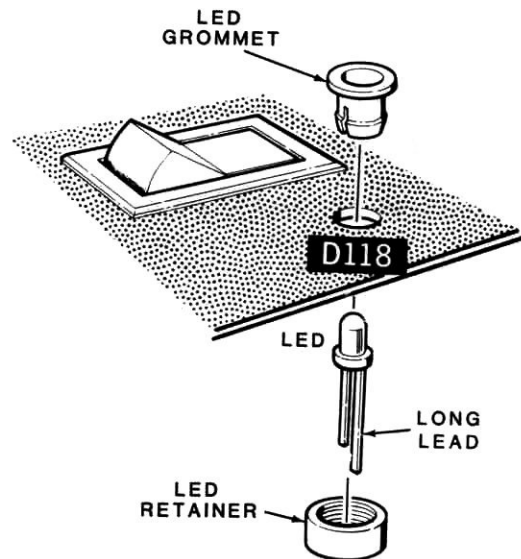

Detail 2-2E

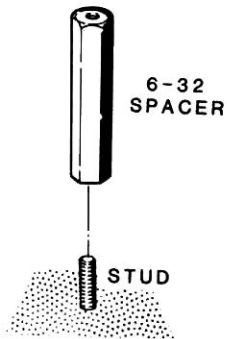

Detail 2-2F

- () Refer to Detail 2-2F and securely turn four 6-32 spacers onto the chassis studs at AJ, AK, AL, and AN.
- () Refer to Detail 2-2G and mount a #6 solder lug on the stud at AH using a 6-32 nut. If necessary, scrape any paint from around this location.

Refer to Detail 2-2H (Illustration Booklet, Page 11) for the following steps.

- () Refer to Part A. Mount the shutter lever at AP with a 4-40 × 3/8" flat head screw, a #5 flat washer, a #4 spring washer, a flat washer, and a 4-40 locknut. Tighten the locknut just enough so the lever can be moved back and forth with some friction.
- () Refer to Part B and mount the front panel and shutter plate at AR and AS with two 4-40 × 3/8" pan head screws and two fiber washers. Make sure the front panel is right-side up and the shutter plate is positioned so the raised portion of the threaded inserts are as shown. Do not securely tighten the screws until you are directed to do so in a following step.
- () Remove the paper backing from the small "CAUTION" label and press the label onto the back of the shutter plate as shown.
- () Remove the backing paper from the foam tape, and install the tape on the chassis flange behind the lever so it **just** touches the lever. Center the tape over the opening.

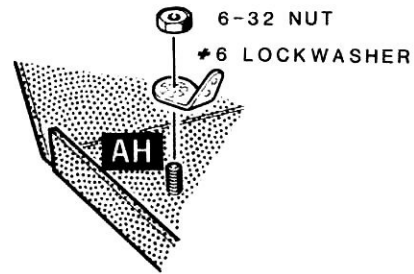

Detail 2-2G

Chassis Wiring

Refer to Pictorial 2-3 (Illustration Booklet, Page 12) for the following steps.

1. NOTES: In the following steps, (NS) means not to solder because other wires will be added later. "S-" with a number, such as (S-2), means to solder the connection. The number following the "S" tells how many wires are at the connection.
 2. Where a wire passes through a connection and then goes to another point, as in the next step, it will count as two wires in the solder instructions (S-2), one entering and one leaving the connection. Be especially careful, when soldering these connections, to apply enough solder and heat to solder these "through wires."
- () Prepare both ends of a 2" small black wire. Remove an additional 1/4" of insulation from one end of the wire. Connect this end of the wire through lug 1 (S-2) to lug 2 (S-1) of J1. Connect the other end of the wire to lug 1 of J2 (NS).
 - () Prepare both ends of a 12" small green, small yellow, and small black wire. Remove 1/4" of insulation from one end and 1/8" from the other end.
 - () Refer to inset drawing #1 and crimp and solder large spring connectors on the 1/8" end of the three wires.

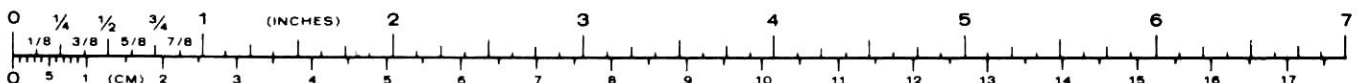

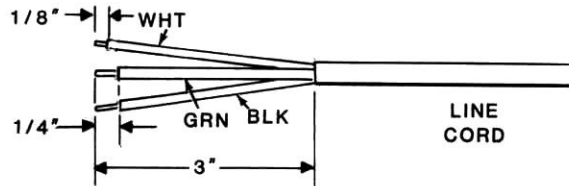

Detail 2-3A

NOTE: In the following steps, you will insert the connectors into the 4-hole socket shell. Be sure to position the socket with the slotted side up and the connectors with the small tab up when you insert them. See inset drawing #1.

- Hole 1 is not used.
- Black in hole 2.
- Yellow in hole 3.
- Green in hole 4.
- Twist the three wires together, except for the last 2".

Connect the wires in the following steps.

- Black wire to lug 1 of J2 (S-2).
- Yellow wire to lug 2 of J2 (S-1).
- Green wire to lug 3 of J1 (S-1).

NOTE: In the following steps, to make a "secure mechanical connection" wrap the wire end tightly all the way around the indicated lug before you solder the connection. See inset drawing #3.

- Prepare both ends of a 2-1/4" medium black wire. Connect the wire from lug 2 of SW101 (S-1) to lug 1 of F101 (S-1). Make a secure mechanical connection.

- Prepare both ends of a 5" medium black wire. Remove 1/4" of insulation from one end and 1/8" from the the other end.
- Refer to inset drawing #2 and crimp and solder a push-on connector on the 1/8" end.
- Connect the other end of this wire to lug 1 of SW101 (S-1). Make a secure mechanical connection.
- Refer to Detail 2-3A and remove an additional 1-3/4" of outer insulation from the end of the line cord (for a total of 3"). Tightly twist the end of each wire and apply a small amount of solder.

- Cut the bare end of the white wire to 1/8".
- Install a push-on connector on the end of the white wire as you did previously with the black wire.

NOTE: When you connect the leads in the following steps, be sure to make secure mechanically connections.

- Insert the line cord through hole AG.
- Connect the green lead to solder lug AH (S-1).
- Connect the black lead to F101 lug 2 (S-1).

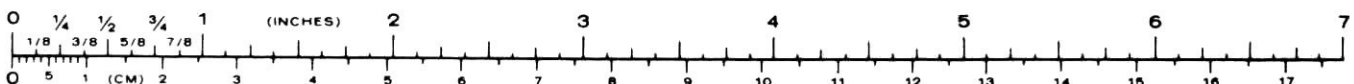

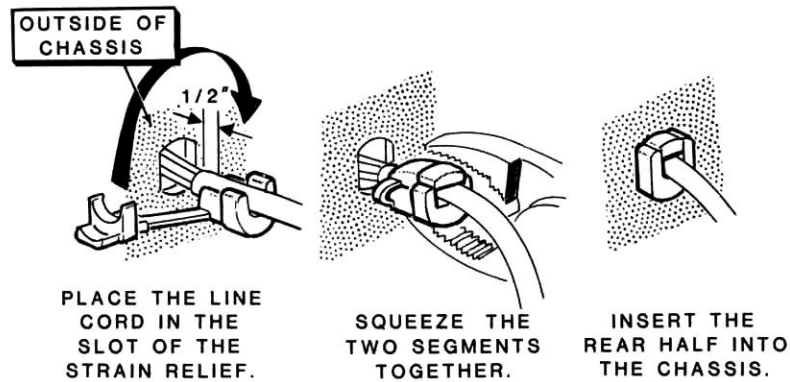

Detail 2-3B

- () Refer to Detail 2-3B and secure the line cord in hole AG with the strain relief.

This completes the chassis wiring. Check the wiring carefully and remove any bits of solder or wire clip-pings that could be lodged in the wiring.

Refer to Pictorial 2-4 (Illustration Booklet, Page 13) for the following steps.

- () Place the circuit board next to the chassis as shown.
- () Insert the black lead coming from SW101 onto terminal A.
- () Insert the white line cord lead onto terminal B.
- () Position socket S101 so the slotted side is as shown and install it on plug P101.

- () Position socket S102 with the slotted side as shown and install it on the leads of D118. Push the socket against the D118 and bend the leads up as shown in the inset drawing.

Refer to Pictorial 2-5 (Illustration Booklet, Page 14) for the following steps.

- () Position the chassis and circuit board as shown. Install the circuit board on the spacers with four 6-32 × 3/8" pan head screws. Make sure the wires connected to the two sockets are routed along the side of the chassis, between the spacers, and **directly across the center** of the circuit board.

This completes the assembly of your Laser Trainer. Proceed to "Laser Safety." After you have read that section of the Manual, proceed directly to "Laser Beam Adjustment."

LASER SAFETY

INTRODUCTION

IMPORTANT: Read this section of the Manual carefully before you operate your Laser Trainer.

The use of protective eyewear or other protective procedures while you are using this product, depends on the condition of use, visual function required, and type of user product. In the United States, you may consult the American National Standards Institute (ANSI), the American Conference of Governmental Industrial Hygienists (ACGIH), or the Occupational Safety and Health Act (OSHA) for information.

The "Laser Radiation" referred to on the attached labels is the 632.8 nm red light output of the laser tube; no X-ray or other harmful radiation is emitted by Heath helium-neon lasers.

WARNINGS:

1. This Laser Trainer has electrical circuits operating at very high voltages that could be lethal. Do not operate the Laser Trainer unless the top cover is installed. The one exception to this is the adjustment of control R110.
2. At all times during operation or maintenance, avoid any unnecessary exposure to laser radiation. This is in compliance with regulation 21 CFR 1040.10 (b) (9).

SAFETY PROCEDURES

1. Never look directly into the laser beam.
2. Perform the experiments so the laser beam is not at eye level.

MAINTENANCE

The following maintenance steps are necessary to keep the Laser Trainer in compliance with regulation 21 CFR 1040.10 and 1040.11. This laser product complies with Title 21 of the United States Code of Federal Regulation Chapter 1, Subchapter J, Parts 1040.10 and 1040.11 as applicable. Once a year, or whenever the Laser has been subjected to adverse environmental conditions such as fire, flood, mechanical abrasion, solvent spillage, etc., inspect it for the following conditions to maintain compliance with these regulations.

1. Make sure that all labels are attached and the aperture lever operates properly. See Figure 1 (Illustration Booklet, Page 15).

CAUTION: Use of controls or adjustments or performance of procedures other than those specified herein may result in hazardous radiation exposure.

LASER BEAM ADJUSTMENT

CAUTION: The use of controls or adjustments or the performance of procedures other than those specified herein may result in hazardous radiation exposure.

BEAM ADJUSTMENT

Position the open chassis on your work area so control R110 is toward you as shown in Pictorial 2-6 (Illustration Booklet, Page 16).

CAUTION: When you make the following control adjustment, **do not touch any part** of the inner chassis components with any part of your body. Use the tip of the alignment tool **only** to adjust control R110.

- () Set control R110 to the center of its rotation.
- () Plug the line cord into an AC outlet; turn ON the POWER switch.

NOTE: In the following steps, if you do not get the correct results, turn the Laser off and unplug the line cord. Then refer to the "In Case of Difficulty" section of the Manual.

- () **Avoid prolonged looking** at the laser tube illumination, but note if its light is flickering. If so, turn control R110 slightly counterclockwise until the flickering just stops and you have even illumination. If the light is not flickering, turn control R110 clockwise until the light just starts to flicker, then counterclockwise until the flickering just stops. **NOTE:** If you have also purchased the Laser Receiver, Model ETA-4200, further instructions for the adjustment of control R110 will follow in a later step.
- () Turn the POWER switch OFF.

SHUTTER ADJUSTMENT

- () Make sure the shutter lever is open (to the right).
- () Position the front of the Laser toward a wall and approximately 12" from it.
- () Turn the POWER switch ON.
- () Adjust the front panel up, down, or sideways as necessary until the laser beam strikes the wall.
- () Refer to Pictorial 2-7 (Illustration Booklet, Page 16) and carefully sight over the top of the laser tube from the line-cord end of the chassis. Observe whether the laser beam strikes **any portion** of the **moveable front panel**; if so, slightly adjust the front panel as necessary so it does not. Then tighten the two front panel screws.
- () Turn the POWER switch OFF.

This completes the "Shutter Adjustment."

ADJUSTMENT USING RECEIVER

NOTE: If you have access to the ETA-4200 Laser Receiver, you may fine-tune control R110 as directed in the following steps. For this, you will also need a radio that has a small phone plug output jack.

Refer to Pictorial 2-8 (Illustration Booklet, Page 17) for the following steps.

- () Turn ON the POWER switch of the Laser Trainer and allow it to warm up for five minutes.
- () Tune your radio to a good clear signal.

NOTE: Be sure you have made the necessary adjustments to the Laser Receiver as directed in that Manual.

- () Push the phono plug on the adapter cable you received with the Laser Receiver into the radio output jack, and the phono plug into the AUX input on the Laser Trainer as shown.
- () Position the Laser Trainer approximately 12" away from the Receiver, with the Trainer beam aperture pointing directly toward the Receiver SENSOR opening.
- () Push the Receiver switch to ON.
- () To avoid overdriving the laser, turn the radio volume up until the light inside the laser tube just starts to flicker; then turn the volume down until the flickering stops.
- () Listen for the clarity of sound coming from the Receiver's speaker. With the alignment tool, adjust control R110 (on the Laser Trainer) for the best sound clarity possible. NOTE: Be careful not to move the Trainer while you are performing this step.
- () Turn the POWER switches on the Laser and on the Receiver to OFF.
- () Disconnect the radio from the Trainer and set the adapter aside in a safe place for later use.
- () Disconnect the Trainer line cord from its AC outlet.
- () Refer back to Pictorial 2-5 and secure the top cover to the Laser Trainer chassis with eight 6-32 × 3/8" self-tapping screws and two 6-32 × 1/4" phillips head screws as shown.

NOTE: It is remotely possible that the tensioning of the cabinet screws may deflect the laser beam very slightly. We suggest that you once again plug in the line cord, turn ON the Trainer power, and position the unit so the beam is aimed at a nearby wall. If the beam appears to be distorted, remove the cabinet screws and repeat the steps as directed in the "Shutter Adjustment" above.

This completes the "Laser Beam Adjustment."

IN CASE OF DIFFICULTY

This part of the Manual will help you locate and correct any difficulty that might occur in your Laser Trainer. This information is divided into two sections. The first section, "General," contains suggestions for reviewing your kit to locate possible causes of incorrect performance.

The second section is a "Troubleshooting Chart." This chart calls out specific problems that may occur and lists one or more conditions or components that could cause each difficulty.

NOTE: In an extreme case where you are unable to resolve a difficulty, refer to "Customer Service" information inside the rear cover of the Manual. Your Warranty is located inside the front cover.

GENERAL

1. Recheck the wiring. Trace each lead in colored pencil on the Pictorial as you check it. It is frequently helpful to have a friend check your work. Someone who is not familiar with the unit may notice something you consistently overlook.
2. Check for bits of solder, wire ends, or other foreign matter which may be lodged in the wiring.
3. About 90% of the kits that are returned for repair do not function properly due to poor connections and soldering. Therefore, you can often eliminate many troubles by reheating all connections to make sure they are soldered properly, as described in the soldering instructions in the Manual.
4. Check each circuit board foil to be sure there are no solder bridges between adjacent connections. Remove any solder bridges by holding a clean soldering iron tip between the two points that are bridged until the excess solder flows **down** onto the tip of the soldering iron.
5. Be sure each transistor is in the proper location (correct part number or type number). Be sure that each transistor lead is in the right hole and has a good solder connection to the foil.
6. Check capacitor values carefully. Be sure the proper part is wired into the circuit at each capacitor location. For example, it would be easy to mistake a .001 μF capacitor for a 100 pF capacitor. Check each electrolytic capacitor to be sure the lead near the positive (+) marking is at the correct position. Check and make sure that each ceramic capacitor that has a known voltage rating is installed at the correct location.
7. Check each resistor value carefully. It would be easy, for example, to install a 2200 Ω (red-red-red) resistor where a 220 Ω (red-red-brown) resistor is called for. A resistor that is discolored, or cracked, or shows any sign of bulging would indicate that it is faulty and should be replaced.
8. Be sure the correct diode is installed at each diode location, and that the banded end is positioned correctly.
9. Check all component leads connected to the circuit boards. Make sure the leads do not extend through the circuit board and come in contact with other connections or parts, such as the chassis.
10. Check all the wires that are connected to the circuit board plugs. Be sure plugs are properly oriented, that plug wires are in their correct holes, and that plugs and sockets are not offset when connected together. Make sure the wires do not touch the chassis or other lugs. Make sure all wires are properly soldered.

11. If you still cannot locate the trouble and a voltmeter is available, check the voltage readings against those shown on the Schematic Diagram. A review of the "Circuit Description" may help you locate the trouble.

NOTE: To remove faulty multi-lead components from a circuit board, clip all the leads, and then unsolder and remove them one at a time.

NOTE: Refer to the "Circuit Board X-Ray View" on Page 18 of the Illustration Booklet for the physical location of parts.

TROUBLESHOOTING CHART

This Troubleshooting Chart lists specific problems that could occur in your Laser Trainer and some possible causes. When the "Possible Cause" column indicates a component (such as D105, for example), check that part and any other components connected directly to it to see that they are installed correctly.

Also check, if possible, to see that the component is working properly. The numbers for the components are the same numbers used in the schematic diagram and circuit description. A circuit board X-ray view is provided on Illustration Booklet Page 18) to help you locate any circuit board component.

PROBLEM	POSSIBLE CAUSE
Arcing sound when switch SW101 is turned on.	<ol style="list-style-type: none"> 1. Solder bridge between foil patterns. 2. Resistors R108 and R109 are arcing together.
Laser tube is not on but LED D118 is lit.	<ol style="list-style-type: none"> 1. Diodes D105, D106, D107, D108, D109, D111, D112, or D113. 2. Capacitors C113, C114, C115, C117, C118, C119, C121, or C122. 3. R110 not properly adjusted.
Laser tube and LED D118 not on.	<ol style="list-style-type: none"> 1. Transistor Q101. 2. Diodes D101, D102, D103, or D104. 3. Zener diode ZD101. 4. Fuse F101.
Laser tube on, but no modulation.	<ol style="list-style-type: none"> 1. Transistors Q102, Q103, Q104, Q105, Q106, Q107, or Q108. 2. Diodes D116 or D117.
Laser tube on, but no modulation. LED D118 not on.	<ol style="list-style-type: none"> 1. Diodes D114 or D115.
Laser tube on, beam flickers.	<ol style="list-style-type: none"> 1. Control R110. 2. Resistor R104. 3. Transistor Q101.

SPECIFICATIONS

Output Power4 mW to .9 mW.
Wavelength	632.8 nM, visible red.
Beam Diameters	at 1/ePTS .49 mm.
Beam divergence	1.64 mrad.
Polarization	Random.
DHHS Class (Department Of Health And Human Services)	II.
Modulation Bandwidth	300 Hz to 40 kHz \pm 3 dB.
Auxiliary Input	1 volt, peak-to-peak.
Microphone	100 mV, peak-to-peak, designed for crystal microphone of 50k impedance.
Power Requirements	120 VAC, 60 Hz, 15 watts.
Dimensions	3-1/4"H \times 3-3/4"W \times 13-7/8"L (8.25 \times 9.5 \times 35 cm).
Net Weight	2.6 lbs.(1.2 kg.).

The Heath Company reserves the right to discontinue products and to change specifications at any time without incurring any obligation to incorporate new features in products previously sold.

CIRCUIT DESCRIPTION

You may use this Circuit Description as an aid in troubleshooting the circuit. Refer to the Schematic Diagram (Illustration Booklet, Page 19) as you read the following paragraphs.

The AC line voltage is rectified by diodes D101-104. Components L101, C101, C102, and C103 form the line filter. This circuit filters out any line-conducted RF interference. Choke L102 and capacitor C108 filter the DC voltage.

The DC voltage from the bridge rectifier drives the 32 kHz oscillator consisting of transistor Q101, capacitors C111 and C112, resistors R102, R103, and R104, and transformer T101. Zener diode ZD101 and resistor R102 provide the oscillator with a fixed base reference voltage. A variable resistor, control R110, is used to adjust the oscillator output amplitude. When the oscillator is running, a 32 kHz line-isolated signal is generated at both of the transformer secondaries.

The voltage from one secondary winding of transformer T101 is fed to a voltage doubler circuit consisting of capacitors C113, C114, and C115, resistor R105, and diodes D105 and D106. This voltage also drives a voltage tripler circuit consisting of resistors R106 and R107, diodes D107, D108, D109, D111, D112, and D113, and capacitors C116, C117, C118, C119, C121, and C122. The voltage tripler develops a voltage of approximately 4200 volts, which is only required to fire the laser tube to turn it on. After

the tube is turned on, the voltage tripler is cut off. The laser tube is then operated from the voltage doubler at - 1400 volts.

The voltage from the other secondary winding of transformer T101 goes to two voltage doublers. Capacitor C123, diode D115, and capacitor C125 form the + 15 volt doubler; and C124, diode D116, and capacitor C126 form the - 15 volt doubler.

Transistor Q102 and its associated circuitry, consisting of resistors R112 through R116 and capacitor C132, provide the required amplification for a microphone with at least a 50 k Ω impedance, such as a crystal microphone. Microphone input J1 is labeled "MIC" on the rear panel. The AUX jack, J2 (also on the back of the Trainer), can be used with any input signal up to a maximum of 1 volt peak-to-peak, such as a signal from a function generator or an auxiliary output from a radio.

Transistors Q103-Q105 and their associated circuits amplify and condition all signals used to modulate the laser tube. Transistor Q106 varies the tube's current, which modulates its beam's brightness. The laser tube can be modulated about 10% of its full power. If it is overmodulated, it will attempt to turn itself off, and this will cause the beam to flicker on and off. Transistors Q107 and Q108 are used to protect transistor Q106 from the tube's high anode voltages.

SEMICONDUCTOR IDENTIFICATION CHART

<u>COMPONENT NUMBER</u>	<u>HEATH PART NUMBER</u>	<u>MAY BE REPLACED WITH</u>	<u>KEY NO.</u>
DIODES			
D101-D104	57-27	1N2071	A1
D105-D113	57-610	FM50	A1
D114-D117	57-56	1N4149	A1
D118	412-658	LED	A2
ZD101	56-99	1N5223B	A1
TRANSISTORS			
Q101	417-814	DTS409	B1
Q102-Q105	417-875	2N3904	B2
Q106	417-874	2N3906	B2
Q107, Q108	417-904	MPSU60	B3

A1

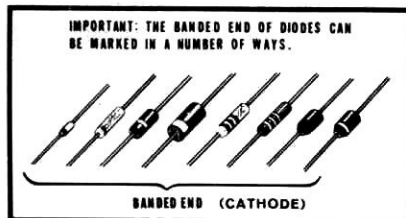

A2

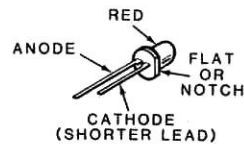

B1

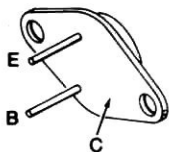

B2

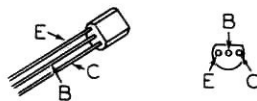

B3

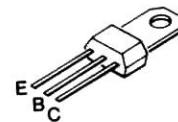

CUSTOMER SERVICE

REPLACEMENT PARTS

Please provide complete information when you request replacements from either the factory or Heath/Zenith Computers and Electronics centers. Be certain to include the **HEATH** part number exactly as it appears in the parts list.

ORDERING FROM THE FACTORY

Print all of the information requested on the parts order form furnished with this product and mail it to Heath. For telephone orders (parts only) dial 616 982-3571. If you are unable to locate an order form, write us a letter or card including:

- Heath part number.
- Model number.
- Date of purchase.
- Location purchased or invoice number.
- Nature of the defect.
- Your payment or authorization for COD shipment of parts not covered by warranty.

Mail letters to: Heath Company
Benton Harbor
MI 49022
Attn: Parts Replacement

Retain original parts until you receive replacements. Parts that should be returned to the factory will be listed on your packing slip.

OBTAINING REPLACEMENTS FROM HEATH/ZENITH COMPUTER AND ELECTRONICS CENTERS

For your convenience, "over the counter" replacement parts are available from the Heath/Zenith Computer and Electronics centers listed in your catalog. Be sure to bring in the original part and purchase invoice when you request a warranty replacement from a Heath/Zenith Computer and Electronics center.

TECHNICAL CONSULTATION

Need help with your kit? — Self-Service? — Construction? — Operation? — Call or write for assistance. You'll find our Technical Consultants eager to help with just about any technical problem except "customizing" for unique applications.

The effectiveness of our consultation service depends on the information you furnish. Be sure to tell us:

- The Model number and Series number from the blue and white label.
- The date of purchase.
- An exact description of the difficulty.
- Everything you have done in attempting to correct the problem.

Also include switch positions, connections to other units, operating procedures, voltage readings, and any other information you think might be helpful.

Please do not send parts for testing, unless this is specifically requested by our Consultants.

Hints: Telephone traffic is lightest at midweek — please be sure your Manual and notes are on hand when you call.

Heath/Zenith Computer and Electronics center facilities are also available for telephone or "walk-in" personal assistance.

REPAIR SERVICE

Service facilities are available, if they are needed, to repair your completed kit. (Kits that have been modified, soldered with paste flux or acid core solder, cannot be accepted for repair.)

If it is convenient, personally deliver your kit to a Heath/Zenith Computers and Electronics center. For warranty parts replacement, supply a copy of the invoice or sales slip.

If you prefer to ship your kit to the factory, attach a letter containing the following information directly to the unit:

- Your name and address.
- Date of purchase and invoice number.
- Copies of all correspondence relevant to the service of the kit.
- A brief description of the difficulty.
- Authorization to return your kit COD for the service and shipping charges. (This will reduce the possibility of delay.)

Check the equipment to see that all screws and parts are secured. (Do not include any wooden cabinets or color television picture tubes, as these are easily damaged in shipment. Do not include the kit Manual.) Place the equipment in a strong carton with at least **THREE INCHES** of *resilient* packing material (shredded paper, excelsior, etc.) on all sides. Use additional packing material where there are protrusions (control sticks, large knobs, etc.). If the unit weighs over 15 lbs., place this carton in another one with 3/4" of packing material between the two.

Seal the carton with reinforced gummed tape, tie it with a strong cord, and mark it "Fragile" on at least two sides. Remember, the carrier will not accept liability for shipping damage if the unit is insufficiently packed. Ship by prepaid express, United Parcel Service, or insured Parcel Post to:

Heath Company
Service Department
Benton Harbor, Michigan 49022



HEATH COMPANY • BENTON HARBOR, MICHIGAN
THE WORLD'S FINEST ELECTRONIC EQUIPMENT IN KIT FORM

LITHO IN U.S.A.