

BYTE

the small systems journal

WORKSHOP

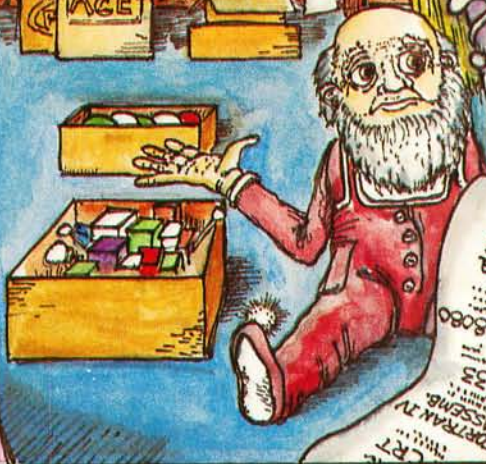



6800-SOFTWARE

WARNING – It has been determined that reading this ad may be hazardous to your health, if you own another type computer system. We will not be responsible for ulcers, heartburn, or other complications if you persist in reading this material.

4 K BASIC[®] — 8 K BASIC[®]

- * Full floating point math
- * 1.0E-99 to 9.99999999E+99 number range
- * User programs may be saved and loaded
- * Direct mode provided for most statements
- * Will run most programs in 8K bytes of memory (4K Version) or 12K bytes of memory (8K Version)
- * USER function provided to call machine language programs
- * String variables and trig functions—8K BASIC only

COMMANDS

LIST
 RUN
 NEW
 SAVE
 LOAD
 PATCH

REM
 DIM
 DATA
 READ
 RESTORE
 LET*
 FOR

STATEMENTS

END
 GOTO* STOP
 ON...GOTO* GOSUB*
 ON...GOSUB* PATCH*
 IF...THEN* RETURN
 INPUT † DES
 PRINT* † PEEK
 NEXT † POKE

FUNCTIONS

ABS † VAL † SIN
 INT † EXT\$ † COS
 RND † LENS † TAN
 SGN † LEFT\$ † EXP
 CHR † MID\$ † LOG
 USER † RIGHTS † SQRT
 TAB

* Direct mode statements
 † 8K Version only

MATH OPERATORS

- (unary) Negate
 * Multiplication
 / Division
 + Addition
 - Subtraction
 † † Exponent

RELATIONAL OPERATORS

= Equal
 < > Not Equal
 < Less Than
 > Greater Than
 <= Less Than or Equal
 >= Greater Than or Equal



© Copyright 1976 by Southwest Technical Products Corp. 4K and 8K BASIC Version 1.0 program material and manual may be copied for personal use only. No duplication or modification for commercial use of any kind is authorized.



You guys are out of your minds, but who am I to complain. Send —

- 4K BASIC CASSETTE \$4.95 MP-68 Computer Kit \$395.00
 8K BASIC CASSETTE \$9.95

NAME _____

ADDRESS _____

CITY _____

STATE _____

ZIP _____

Southwest Technical Products Corp.
 Box 32040, San Antonio, Texas 78284

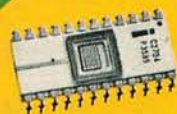
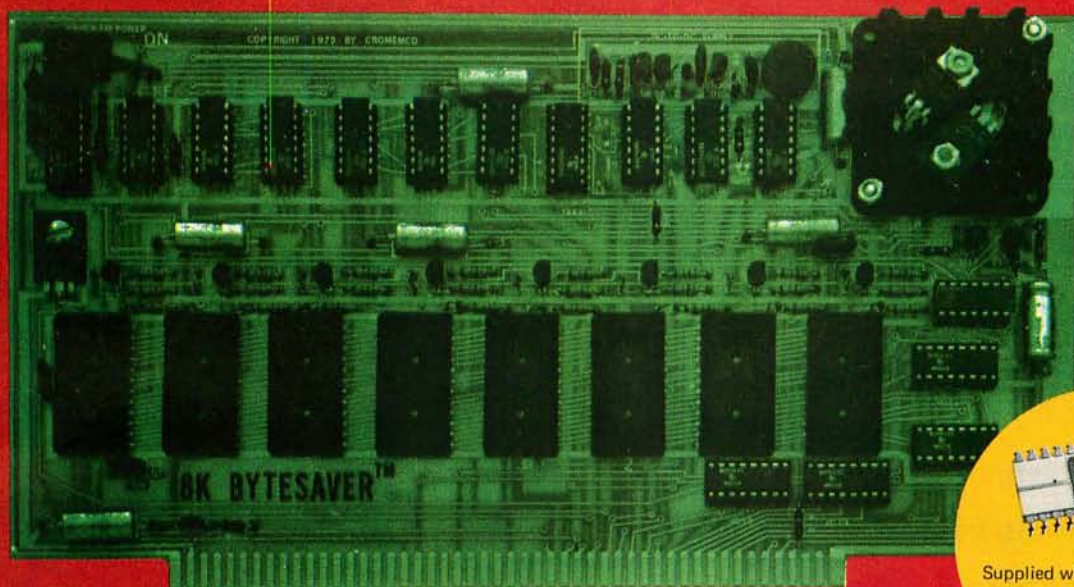

Supplied with one 2704 PROM containing special software to transfer RAM content to PROM and PROM to RAM.

How to save your programs -- and have a PROM programmer, too

Cromemco's popular BYTESAVER™ memory board gives you two of the most-wanted features in microcomputer work:

- (1) a simple, easy way to store your computer programs in programmable read only memory (PROM).
- (2) a PROM memory board with the capacity for a full 8K bytes of PROM memory storage.

ECONOMICAL

The BYTESAVER™ is both a place and a way to store programs economically. It transfers programs from the non-permanent computer RAM memory to the permanent PROM memory in the BYTESAVER™. Once your program is in the BYTESAVER™, it's protected from power turn-offs, intentional or accidental. The PROMs used with BYTESAVER™ are UV erasable and can be used again and again.

The BYTESAVER™ itself plugs directly into your Altair 8800 or IMSAI 8080.

PROM PROGRAMMER

Many people are surprised to learn that in the BYTESAVER™ you also have your own PROM programmer. But

it's so. And it saves you up to hundreds of dollars, since you no longer need to buy one separately.

The built-in programmer is designed for the 2704 and 2708 PROMs. The 2708 holds 1K bytes, four times the capacity of the well-known older 1702 PROM (yet cost-per-byte is about the same). The 2708 is also fast — it lets your computer work at its speed without a wait state. And it's low-powered. With 2708's in all 8 sockets, the BYTESAVER™ is still within MITS bus specifications, drawing only about 500 mA from the +8V bus. A complement of 2708 PROMs gives the BYTESAVER™ its full 8K capacity.

HOLDS LARGE PROGRAMS

The BYTESAVER's™ 8K-byte capacity lets you store the larger and more powerful programs. 8K BASIC, for example, easily fits in the BYTESAVER™ capacity of 8 PROMs. One 1K PROM will hold many games such as Cromemco's DAZZLER-LIFE or DAZZLE-WRITER.

NO KEYBOARD NEEDED

The BYTESAVER™ comes with special software programmed into a 2704 PROM. This software controls transfer of the computer RAM content to the BYTESAVER™ PROM.

So you are ready to go. You don't

even need a keyboard. Just set the computer sense switches as instructed in the BYTESAVER™ documentation.

Transfer of memory content to PROM ("burning") takes less than a minute. The BYTESAVER™ software controls computer lights to verify complete and accurate transfer of memory content.

The software also programs any of the other 7 PROM positions in the BYTESAVER™ as readily as the first.

And when used to transfer information from the BYTESAVER™ PROMs to RAM, the special design of the software allows loading a large program such as 8K BASIC in one second.

AVAILABLE NOW — STORE/MAIL

The BYTESAVER™ is sold at computer stores from coast to coast. Or order by mail from Cromemco. Cromemco ships promptly. You can have the BYTESAVER™ in your computer within a week after your order is received.

BYTESAVER™ kit \$195
(Model 8KBS-K)

BYTESAVER™ assembled \$295
(Model 8KBS-W)

Shipped prepaid if fully paid with order.

California users add 6% sales tax.

Mastercharge and BankAmericard accepted with signed order.



Cromemco

Specialists in computer peripherals
2432 Charleston Rd., Mountain View, CA 94043 • (415) 964-7400

In This BYTE

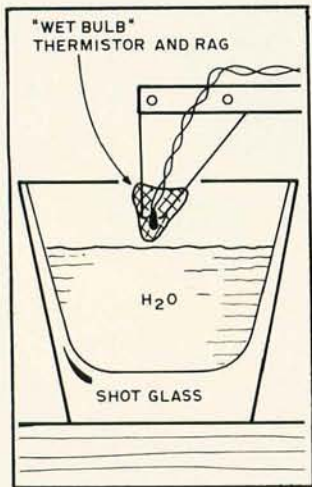

page
62

pages
24,
139

If you're into programmable calculators, you've probably heard lots of rumors around the computer world about all those SR-52 hidden features, dug up by persistent and ingenious users who look upon the calculator as a puzzle. Well, confirm the rumors with Clif Penn's *The Buried Gold in the SR-52* written using "inside" information from Texas Instruments in Dallas where he works.



The information on machine readable printed software continues this month, with three articles. Introducing the subject for this issue is a short note by Walter Banks and Roger Sanderson presenting several detailed **Samples of Machine Readable Printed Software** at different densities, which our readers can use as test strings for experimental input hardware and software. In addition to the samples, Walter and Roger present some of their philosophical comments on the method and what led them to propose it.

Bar codes are an exciting new way to publish software in machine readable form. Turn to Keith Regli's article to find out about **Software for Reading Bar Codes** in the form of an algorithm specification for one approach to the problem.

Good things come in small packages. One such package was an envelope with nine excellent color slides by Margot Critchfield for our Computer Art Contest, along with an article by Thomas Dwyer and Leonard Sweer on *The Cybernetic Crayon* which was used by Margot to draw the pictures.

A key element of the complete computer system is a video display output device. In this issue, you'll find D Anderson's experiences with the **Processor Technology VDM-1** summarized in the form of a **Product Review** and some software illustrating its use.

What happens when your speedy second generation microprocessor cannot keep pace with your turtle-like 1702 erasable read only memories? Why, buy some extra time with a slow memory interface circuit of course. Learn how to **Stretch That 6800 Clock** with Jerry Henshaw's article on an elegant modification to the Southwest Technical Products Corporation's 6800 processor.

If your memory space is limited, a bit of frugality in coding your character strings can save bits. Robert Baker shows **One Way to Squeeze Fat Out of Text Strings** in a bit packing scheme described in his article **Don't Waste Memory Space**.

Weather you do it or not, you'll enjoy Mike R Firth's ideas on how to create an automated weather station. **Do It Yourself Weather** predictions could conceivably be a whole field of home computer applications in itself.

To read a bar code requires a bit of signal processing in the analog world, prior to sending your processor a single bit TTL level signal. In his article on **Signal Processing for Optical Bar Code Scanning**, Fred Merkwitz provides some details on how to read the signals coming from photo diodes and photo transistors.

One of the signs of progress in the marketplace is the appearance of neat product concepts to service the peripherals needs of personal computing people. An excellent example of this is the new Southwest Technical Products AC-30 Cassette Interface, a modulator, demodulator and switching network which is designed to fit into an RS-232 communications line between the computer and a 300 baud terminal. It adds the functions of tape recording and data recovery, with relays to control motor action automatically. Gary Kay, the designer of this interface, describes the circuit and its function in this issue.

One of the simplest and least expensive possible computer projects is a **Universal Turing Machine** or UTM. While hardly offering the UTMost in speed or performance, a UTM based on Jonathan K Millen's design would make an excellent tutorial project for a computer science laboratory course.

Now you can buy an Altair™ 8800b or an Altair 680b computer right off the shelf. Altair plug-in boards, peripherals, software and manuals are also available. Check the list below for the MITS dealer in your area.



off the shelf.

RETAIL COMPUTER STORE, INC.
Tim & Susanne Broom
410 NE 72nd St.
SEATTLE, WA 98115
(206) 524-4101

COMPUTER KITS (S. F. area)
Pete Roberts
1044 University Ave.
BERKELEY, CA 94710
(415) 845-5300

THE COMPUTER STORE
(Arrowhead Computer Co.)
Dick Heiser
820 Broadway
SANTA MONICA, CA 90401
(213) 451-0713

GATEWAY ELECTRONICS, INC.
George Mensik OF COLORADO
2839 W. 44th Ave.
DENVER, CO 80211
(303) 458-5444

COMPUTER SHACK
Pete Conner
3120 San Mateo NE
ALBUQUERQUE, NM 87110
(505) 883-8282, 883-8283

GLOBAL ENGINEERING CO.
5416 South Yale
TULSA, OKLA. 74145
(918) 452-2567

COMPUTER PRODUCTS UNLIMITED
Harry & Margaret Mohrmann
4216 West 12th
LITTLE ROCK, AR 72204
(501) 666-2839

GATEWAY ELECTRONICS, INC.
Harry & Margaret Mohrmann
Lou Elkins, Stuart Bartfield
8123-25 Page Blvd.
ST. LOUIS, MO 63130
(314) 427-6116

CHICAGO COMPUTER STORE
Lou Van Eperen
517 Talcott Rd.
PARK RIDGE, IL 60068
(312) 823-2388

THE COMPUTER ROOM
3938 Beau D'Rue Drive
Eagan, MN 55122
Dale Hagert, Bob Raemer
(612) 452-2567

BYTE'RONICS
John & Stan Morrow
Suite 103
1600 Hayes St.
NASHVILLE, TN 37203
(615) 329-1979

THE COMPUTER SYSTEMCENTER
Jim Dunion, Rich Stafford,
Steven Mann, Ron Roberts
3330 Piedmont Road
ATLANTA, GA 30305
(404) 231-1691

THE COMPUTER STORE, INC.
Sid Halligan
120 Cambridge St.
BURLINGTON, MA 01803
(617) 272-8770
Jeff Feldman, Service Dept.

THE COMPUTER STORE OF NEW YORK
Bob Arning
55 West 39th St.
NEW YORK, NEW YORK 10018
(212) 221-1404

THE COMPUTER STORE OF
Peter Blond ANN ARBOR
310 East Washington Street
ANN ARBOR, MI 48104
(313) 995-7616

THE COMPUTER STORE, INC. (Hartford area)
George & Susan Gilpatrick
63 South Main Street
WINDSOR LOCKS, CT 06096
(203) 627-0188

MICROSYSTEMS (Washington, D.C.)
Gloria & Russell Banks
6605A Backlick Rd.
SPRINGFIELD, VA 22150
(703) 569-1110

THE COMPUTER STORE
Stephen Payne
1114 Charleston National Plaza
CHARLESTON, W. VA. 25301
(304) 343-4607

MARSH DATA SYSTEMS
Don Marsh
5405 B Southern Comfort Blvd.
TAMPA, FL 33614
(813) 886-9890



Meet the Challenger.™

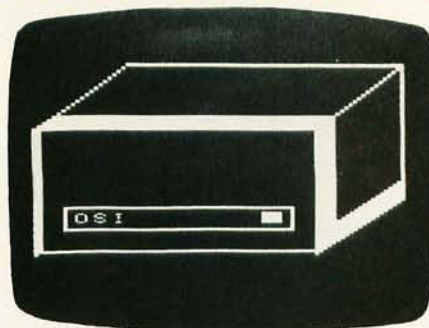

The Challenger
Self Portrait

The new price and performance champ from OSI.

He's got his act together!

Even our lowest-cost Challenger comes fully assembled, complete with a 500 ns 6502A, serial interface, 1,024 words of memory and a UL-approved power supply, all for \$439. Every Challenger comes ready for easy expansion with an 8-slot mother board, backplane expansion capability, and a power supply heavy enough to handle a full complement of system boards. Our 4K Challenger comes ready to run BASIC minutes after you unpack it. And there's more.

He packs some heavy hardware.

You've never seen memory and interface options like these—not at our prices, fully assembled! 4K RAM memory boards \$139! (see below). Single drive OSI Challenger Floppy Disk \$990! Dual drive Floppy \$1490! Plus 8K PROM boards! A Video Graphics board, including alphabetics, graphics, and color! An audio cassette, A/D, D/A and parallel I/O board! A backplane extender board! A prototyping board! And our extraordinary **CPU Expander Board**—it lets you run a Z-80, and 6100 (PDP-8 equivalent) **concurrently** with The Challenger's 6502, or under its control.

There's nothing soft about his software!

OSI has full software support for our Challengers. Including extended BASIC, extended Video Monitor, a Disk Operating System, some very Hollywood real time programs for Video Graphics, Animation, Sound Processing and so forth, plus PROM firmware, with more to come.

He's fast!

You can order The Challenger with a 6502C for a 250 ns cycle time, with a standard 6502A for 500 ns cycle time, or with a 6800 for 1 microsecond cycle time. And with

our CPU Expander Board, you can always update to any new CPU to be as fast as fast can be.

And he isn't just good!

He's better! By design. The OSI Challenger is the only completely-assembled, ultra-high-performance, fully-expandable mainframe computer that does this much for this little. Get your hands on one now. Send for your Challenger today.

You can't beat The Challenger!

The OSI Challenger 65-1K. Fully assembled. Features 6502A CPU, serial interface, 1,024 words of memory. **\$439.**

The OSI Challenger 65-4K. Same as 65-1K but with 4,096 words of memory. Will run Tiny BASIC without expansion. **\$529.**

The OSI Challenger 65V-4K. NO NEED for an expensive terminal. Connects to your ASCII keyboard and video monitor through included OSI 440 Video Board. Features software utility that simulates a deluxe CRT terminal. **\$675.**

The OSI Challenger 68-1K. Based on 6800 CPU. For the casual hobbyist, smaller systems. The Challenger 68 series comes only in serial interface forms and is compatible with MIKBUG software through an included OSI software utilities package. **\$459.**

The OSI Challenger 68-4K. With OSI 4K BASIC on paper tape. **\$529** SPECIAL! ADDITIONAL 4K MEMORY BOARDS. Ordered with your Challenger, limit 3 more at this special Low Price, (total 16K, including 4K already on-board in mainframe). **\$139** Buy 12K or larger Challenger 65 system and we include Extended BASIC FREE!

OSI Challenger Floppy Disk System. Fully assembled, for use with OSI Computers only. **\$990** Single drive **\$1490** Dual drive.

OSI Audio Cassette Interface. Comes assembled, but with room for you to populate with A/D and D/A chips later. (OSI 430 based) **\$89** And all the baseboards and kits of the powerful OSI 400 System.

OK, OSI, I'm ready to buy!

To order your Challenger System, send the total amount of your purchase plus \$4.00 for shipping and insurance (plus sales tax for Ohio orders) by personal money order or check. Or indicate **all** numbers on your BankAmericard or Master Charge to charge your order. Or send a 20% (non-refundable) deposit to receive your order C.O.D. Delivery is typically 60 days (except when payment is by check, which must clear before shipment can be made). Deliveries are scheduled on a first ordered, first shipped basis.

Name _____

Address _____

City _____ State _____ Zip _____

Telephone _____

Bank card info Inter Bank # _____

Expiration Date _____

Account # _____

Check M. O. BAC MC
20%, bal. C.O.D.

Order attached.
 Send additional information on The OSI Challenger.

Send additional information on OSI 400 Kits.

\$1.00 enclosed for complete OSI Catalog.

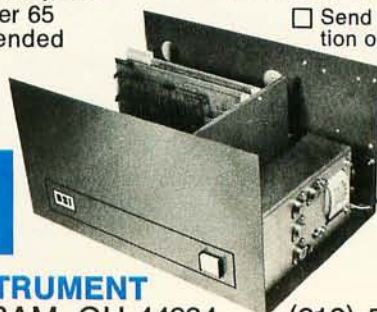

OSI

OHIO SCIENTIFIC INSTRUMENT

Dept. B 11679 HAYDEN STREET, HIRAM, OH 44234

(216) 569-7945

Foreground

- 24 THE CYBERNETIC CRAYON
Graphics Systems — Dwyer-Sweer
- 139 Portfolio of Explorations — Critchfield
- 30 THE BURIED GOLD IN THE SR-52
Systems Programming — Penn
- 42 STRETCH THAT 6800 CLOCK
Hardware Modification — Henshaw
- 58 DON'T WASTE MEMORY SPACE
Software — Baker
- 77 SIGNAL PROCESSING FOR OPTICAL BAR CODE SCANNING
Hardware — Merkowitz
- 98 THE DESIGNER'S EYE VIEW OF THE AC-30
Product Description — Kay
- 114 A UNIVERSAL TURING MACHINE
Hardware — Millen

Background

- 12 SAMPLES OF MACHINE READABLE PRINTED SOFTWARE
PAPERBYTES™ — Banks-Sanderson
- 18 SOFTWARE FOR READING BAR CODES
Software — Regli
- 36 PROCESSOR TECHNOLOGY VDM-1
Product Review — Anderson
- 62 DO IT YOURSELF WEATHER PREDICTIONS
Applications — Firth
- 110 BUILDING THE AC-30 CASSETTE INTERFACE
Review — Liming

Nucleus

- 2 In This BYTE
- 6 Caught by Surprise
- 48 Clubs, Newsletters
- 50 Letters
- 54 BYTE's Bugs
- 56 Ask BYTE
- 60, 87 What's New?
- 70 About the Cover . . . and the Contest
- 86 State of the Art Disk Technology
- 91 Software Bug of the Month 6
- 92 Desk Top Wonders
- 95 The First West Coast Computer Faire
- 60, 96 BYTE's Bits
- 108 Kil O'Byte
- 120 Book Reviews
- 128 Technical Forum
- 132 Programming Quickies
- 144 BOMB
- 144 Reader's Service

BYTE magazine is published monthly by BYTE Publications, Inc, 70 Main St, Peterborough, New Hampshire 03458. Subscription rates are \$12 for one year, \$22 for two years, \$30 for three years in North America. Elsewhere: \$15 one year, \$25 two years, \$33 three years. Second class postage paid at Peterborough New Hampshire 03458 and at additional mailing offices. Phone 603-924-7217. Entire contents © copyright 1976 BYTE Publications, Inc, Peterborough NH 03458. All rights reserved. Address editorial correspondence to Editor, BYTE, 70 Main St, Peterborough NH 03458. Opinions expressed by authors are not necessarily those of BYTE magazine.

PUBLISHERS

Virginia Peschke
Manfred Peschke

EDITOR

Carl T Helmers, Jr

GENERAL MANAGER

Manfred Peschke

PRODUCTION MANAGER

Judith Havey

PRODUCTION EDITOR

Karen Gregory

CO-OP EDITOR

Raymond G A Cote

CIRCULATION

Deborah R Luhrs

DEALER CIRCULATION

Deena Zealy

PUBLISHERS ASSISTANTS

Kimberly Barbour

Debra L Boudrieau

Cheryl Hurd

Anne Jackson

Carol Nyland

Laurie Stuart

ADVERTISING

Elizabeth Alpaugh

Virginia Peschke

TYPOGRAPHY

Custom Marketing Resources, Inc

Goodway Graphics

Mary Lavoie

Taimi Woodward

PHOTOGRAPHY

Ed Crabtree

Custom Marketing Resources, Inc

ART

Matthew Arnold

Noreen Bardsley

Mary Jane Frohlich

Lynn Malo

Bill Morello

PRINTING

The George Banta Company

Custom Marketing Resources, Inc

Lennie Cashion

Larry Davis

Jeff Pratt

ASSOCIATES

Bob Baker

Dan Fylstra

Harold A Mauch

Chris Ryland

SPECIAL PRODUCTS

Susan Pearne

Floyd W Rehling

TECHNICIAN

Melvin G Weir

CONSTRUCTION

Walter Pence

TRAFFIC MANAGER

Peter Travisano

SYSTEMS LIBRARIAN

Richard Gardner

Caught by Surprise

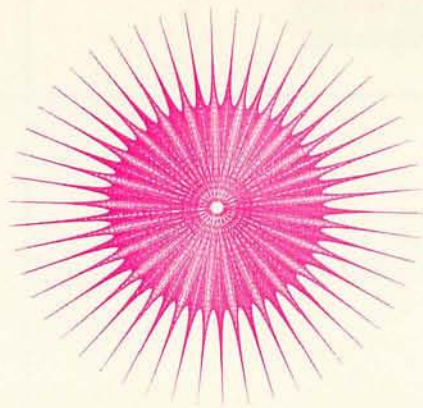

by Carl Helmers

Magenta Magica by
Joseph P Jacobson
Maple Shade NJ 08052
Christian Kuebler
Trevose PA 19047

Sometimes it is fun to take an old Yankee attitude of smugness when one participates in a turn of events which is unexpected, which was not foreseen by many, and which seems to have been missed by established circles. This attitude is one which can be shared by all who participate in this field of personal computing, as designers, as entrepreneurs and as users of the products. Virtually overnight, we — you the reader, you the manufacturer, to say nothing of myself and associates at BYTE and other publications — have demonstrated the existence of supply and demand for products which were nearly completely overlooked by established circles. Elements of this attitude of achievement were present in my conversations with entrepreneurs Bob Marsh (Processor Technology), Chris Rutkowski (Technical Design Labs), Steven Jobs (Apple Computer Co) and Paul Terrell (Byte Shops) on the floor of the WESCON show last September in Los Angeles CA. The attitude crystalized into immediate focus on September 23 when Virginia Peschke and I travelled to Connecticut on business which was followed by a social call at Scelbi Computer Consulting Inc to meet Nat Wadsworth and his associates. [For those unfamiliar with the history of the field, Nat Wadsworth is probably the first person ever to manufacture a general purpose computer kit, the Scelbi 8B and 8H products, based upon an 8008. His product was a real entry into the marketplace, advertised in amateur radio publications long before the Radio Electronics Mark-8 articles of 1974, and long before Ed Roberts, MITS and the Altair were launched on their present course in January 1975 thanks to another pioneer willing to take risks, Leslie Solomon of Popular Electronics. The Scelbi product was a well designed general purpose processor with ROM systems software, conceived shortly after Intel first announced the 8008. Nat later decided that his energies and resources

were best employed by concentrating upon the software, documentation and explanation of computer systems, so he retired the Scelbi product from active hardware marketing.] We started talking about the various people involved in the field, the nature of the business and the amazing lack of participation by the "big," "established" firms we had expected to find jumping on the bandwagon with products tailored to personal computing. This is where we settled on the idea that there is still plenty of room for pioneering in America (or the world, for that matter), and that the established industries with the clogged arteries of a large organization are hardly likely to put a dent in the productivity of the early pioneers. The principle is quite simple: Even within a moderately large trading organization which manages to react quickly to a new idea, innovation and creative marketing are a highly individualistic process. In nearly every case, the people who are involved with the companies and ideas which are burgeoning into this new computer industry had been long employed by or had received training from large established companies in computers and related fields. Numerous examples come to mind. But in the context of the large organization, the energies of many of these people were stifled: An organization which is large tends to think in terms of aggregate capital and conservation of that capital by minimization of risk. The need for a "sure thing" as perceived by all the management participating in a decision tends to water down the magnitude (and hence the profitability if successful) of the marketing risks. In contrast, the individual with the proper "pioneer" frame of mind is one with a clear conception of the market need and a willingness to test that judgment with action.

After having the attitude crystalized in my attention by the conversation with Nat Wadsworth, the subject remained on the tip

The Intecolor® 8001 Christmas Kit Is Now Available Through The Following Authorized Distributors



CALIFORNIA

Byte Shop

155 Blossom Hill Rd.
San Jose, Ca. 95125
(408) 226-8383

Computer Store

1093 Mission St.
San Francisco, Ca. 94103
Al Goodwin
(415) 431-0640

The Computer Center

8205 Ronson Rd.
San Diego, Ca. 92111
John Perry
(714) 292-5302

The Computer Mart of Los Angeles

625 W. Katella No. 10
Orange, Ca. 92667
(714) 635-1222

GEORGIA

The Computer Systems Center

3330 Piedmont Rd., NE
Atlanta, Ga. 30305
(404) 231-1691

ILLINOIS

Itty Bitty Machine

1316 Chicago Ave.
Evanston, Ill. 60201
(312) 328-6800

INDIANA

Home Computer Shop

10447 Chris Dr.
Indianapolis, Ind. 46229
James B. Baughn
(317) 894-3319

MASSACHUSETTS

The Computer Store

120 Cambridge St.
Burlington, Mass. 01805
(617) 272-8770

Or Contact Us Direct Intelligent Systems Corp.®

5965 Peachtree Corners East
Norcross, Georgia 30071
Telephone (404) 449-5961

If you thought a rugged, professional yet affordable computer didn't exist,

think IMSAI 8080.

Sure there are other commercial, high-quality computers that can perform like the 8080. But their prices are 5 times as high. There is a rugged, reliable, industrial computer, with high commercial-type performance. The IMSAI 8080. Fully assembled, it's \$931. Unassembled, it's \$599. And ours is available now.

In our case, you can tell a computer by its cabinet. The IMSAI 8080 is made for commercial users. And it looks it. Inside and out! The cabinet is attractive, heavy-gauge aluminum. The heavy-duty lucite front panel has an extra 8 program controlled LED's. It plugs directly into the Mother Board without a wire harness. And rugged commercial grade paddle switches that are backed up by reliable debouncing circuits. But higher aesthetics on the outside is only the beginning. The guts of the IMSAI 8080 is where its true beauty lies.

The 8080 is optionally expandable to a substantial system with 22 card slots in a single printed circuit board. And the durable card cage is made of commercial-grade anodized aluminum.

The IMSAI 8080 power

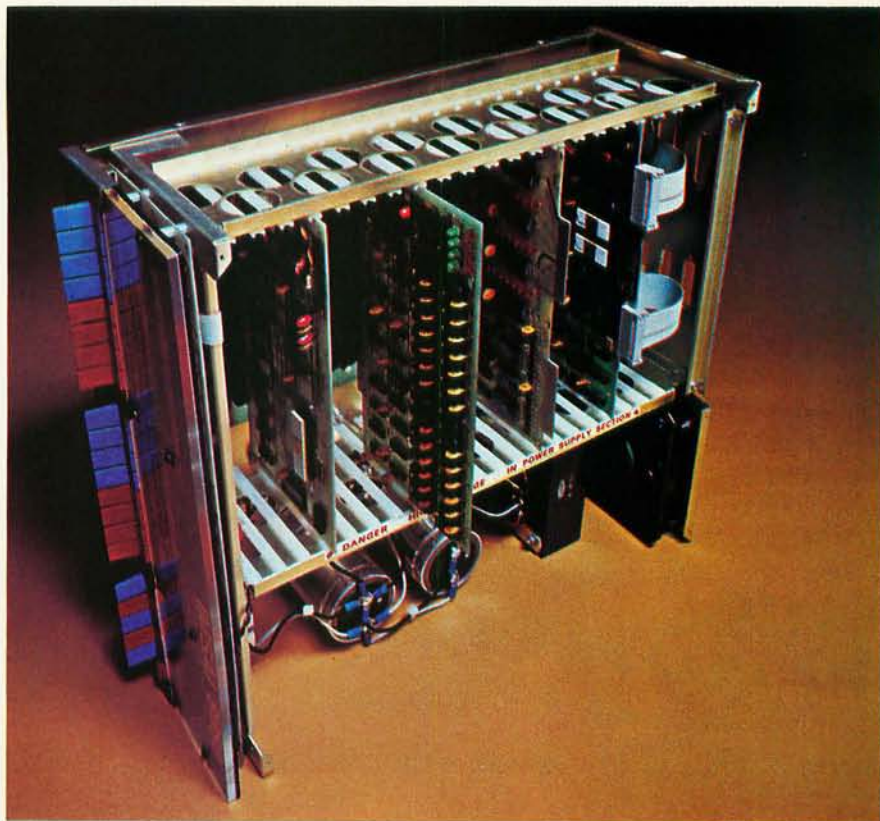

supply produces a true 28 amp current, enough to power a full system.

You can expand to a powerful system with 64K of memory, plus a floppy disk controller, with its own on-board 8080—and a DOS. A floppy disk drive, an audio tape cassette input device, a printer, plus a video terminal and a teleprinter. These peripherals will function with an 8-level priority interrupt system. IMSAI BASIC software is available in 4K, that you can get in PROM. And a new \$139 4K RAM board with software

memory protect. For the ultimate in flexibility, you can design the system for low-cost multiprocessor, shared memory capability.

Find out more about the computer you thought didn't exist. Get a complete illustrated brochure describing the IMSAI 8080, options, peripherals, software, prices and specifications. Send one dollar to cover handling.

Call us for the name of the IMSAI dealer nearest you.

Dealer inquiries invited.

IMSAI

IMSAI Manufacturing Corp. Dept. B-12
14860 Wicks Boulevard
San Leandro, CA 94577
(415) 483-2093



For more information circle A 12.

of a mental iceberg. That mental iceberg hit a mental Titanic which led to this theme and editorial when I attended a session entitled "Is the US Losing Its Technological Leadership?" at the IEEE EASCON gathering held at Stouffer's National Center Inn in Alexandria VA, September 26. The session was an informal round table discussion organized by Dr Russell C Drew of the National Science Foundation. The purpose of the discussion was to air issues of Federal policy which would encourage and promote continuation of a tradition of leadership and innovation which has been perceived by the participants as losing ground in recent times. The theme of the discussion is stated in the EASCON 76 transcript on page 12:

Since the end of World War II, US technical leadership has been largely unquestioned. The growing technical sophistication and economic strength of the developed world however has caused increased attention to prospects for the future and the consequent policies that should be considered.

The discussion started out with an introduction by Dr Drew, stating the problem perceived, then emphasizing that the major area of concern was commercial leadership through technological innovation in world markets. A list of indicators was mentioned, indicators which if believed indeed point to an area of concern. The problem was then defined as a search for federal policy options and incentives needed to restore a healthy situation of technology leadership. This led into a presentation by the first panelist to speak, Dr Betsy Ancker-Johnson of the US Dept of Commerce. Dr Ancker-Johnson's presentation was largely statistical and empirical in orientation, with concern expressed for numerous points:

- Nontechnologically oriented industries are shrinking in world significance.
- US capital investment is seemingly becoming less productive.
- 1 out of every 6 people works for a state or local government (the federal byte was not even mentioned).
- "Inventiveness" as measured by various patent office statistics is down for Americans.
- The statistics for new companies on Wall St and the capital markets are down.

Dr Ancker-Johnson's presentation led in turn to a talk by Dr Courtland Perkins of the National Academy of Engineering, emphasizing what he perceived as a lack of excite-

ment with technological innovation and progress in the universities. He complained about the trend toward the academician, rather than the ideal type of a combined teacher and commercial innovator who inspires a generation of engineers and experimenters to creative results. Words to the effect of "where are the faculty boosters of technology?" summarize a great portion of what Dr Perkins had to say. The next panelist to speak was Dr Burt Edelson of ComSat Laboratories, summarizing his perceptions in the field of satellite communications as practiced by an international bureaucracy called Intelstat, where he perceives a less than optimal role for US interests.

John Eger, currently of the Office of Telecommunications Policy and a lawyer somewhat experienced with the Washington bureaucracy, came out sounding like a genuine natural rights liberal. His answer to the question was effectively "yes, the US is losing its technological leadership, and nobody cares." Washington, in his view, certainly does not help the matter. There has been considerable loss of freedom of action in the marketplace, saddled with regulations of every sort and manner. Since the innovations of free enterprise are based on uncertainty and action designed to alleviate this uncertainty, every regulation which constrains action has the effect of a brake on innovation. This led into the round table of discussion including panel members and various questioners from the audience.

During the round table discussion, one comment was most interesting, in that it was made by Dr Ancker-Johnson of the Department of Commerce. The comment was to the effect "can American business [ie: the American people] afford to waste 150 billion dollars annually on unproductive government overhead?" The fact that such a comment was made by one of the minions of the Washington establishment based on experience and empirical evidence at her command lends quite a bit of credibility to the statement. The consensus of the panel was that US industries are becoming relatively less competitive internationally, and that the US government must reorient its priorities to emphasize our natural advantages in high technology activities. Since markets and consumer desires make the innovation system go, this reorientation requires emphasizing innovation in the marketplace and the incentives of economic upward mobility which produce the needed cornucopia of innovation. Which brings us back to a certain

Articles Policy

BYTE is continually seeking quality manuscripts written by individuals who are applying personal systems, or who have knowledge which will prove useful to our readers. Manuscripts should have double spaced type-written texts with wide margins. Numbering sequences should be maintained separately for figures, tables, photos and listings. Figures and tables should be provided on separate sheets of paper. Photos of technical subjects should be taken with uniform lighting, sharp focus and should be supplied in the form of clear glossy black and white or color prints (if you do not have access to quality photography, items to be photographed can be shipped to us in many cases). Computer listings should be supplied using the darkest ribbons possible on new (not recycled) blank white computer forms or bond paper. Where possible, we would like authors to supply a short statement about their background and experience.

Articles which are accepted are typically acknowledged with a binder check 4 to 8 weeks after receipt. Honorariums for articles are based upon the technical quality and suitability for BYTE's readership and are typically \$25 to \$50 per typeset magazine page. We recommend that authors record their name and address information redundantly on materials submitted, and that a return envelope with postage be supplied in the event the article is not accepted. ■

With this issue, Ray Cote joins BYTE as an assistant editor. Ray is an electrical engineering student taking part in Northeastern University's Cooperative Education Program.

Continued on page 34

CHRISTMAS SOFTWARE SALE

A great idea for gift giving. For that special person who's into computers. A great gift for yourself. Best of all, the prices are lower than ever before! For one month — to BYTE customers only! So order now . . . save, Save, SAVE! Hurry!



Special one-month Price Reduction on SCELBAL-A Higher Level Language for 8008/8080 Systems!

Here's the hot, new language that everyone's talking about . . . SCELBAL! This exciting, completely documented higher level language for 8008/8080 systems is the most comprehensively documented higher level language available today. Order now at the specially reduced price. Save \$10.00 . . . and receive introductory copies of the supporting journal, SCELBAL UPDATE, absolutely FREE! Regular price: \$49.00

Only . . . **39.** Order Now!

Machine Language Programming for 8008 (and similar microcomputers) CLOSE OUT!

Save now! Take advantage of this close-out offer on our popular *Machine Language Programming for 8008 (and similar microcomputers)*. Regularly \$19.95. Close-out priced at only \$14.95! A classic introductory text. Order right now, before the supply runs out. (Only 1,000 copies left)

Order now! Only . . .

14⁹⁵



Scelbi's First Book of Computer Games and Galaxy combination can save you 25%!

Now you can own both of Scelbi's popular computer game books . . . *Scelbi's First Book of Computer Games for 8008/8080* (regularly \$14.95) and the exciting intergalactic war game, *GALAXY* (regularly \$14.95), a \$29.90 value . . . **25% off!** Hurry! Order now before this offer closes on January 10th!

Order both games books now . . . only

22⁹⁵

Three 8080 Software Manuals . . . Monitor, Editor and Assembler at ONE low price!

Scelbi's popular 8080 Software manuals, the Monitor, Editor and Assembler programs, have been prepared for their fourth printing. Rising costs of paper and printing means that we'll soon have to increase the price of these three popular publications. If you act right now, we'll hold the original \$39.50 price. Hurry! Order today before prices go up. Save!

All three now only **39⁵⁰**

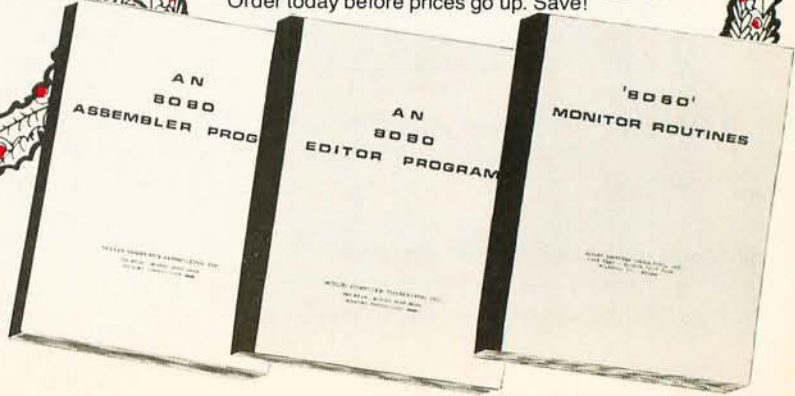

Hurry! Order right now! The prices offered in this advertisement expire January 10, 1977. Be sure to mention this ad in BYTE!

**ACT NOW! ORDER THESE POPULAR
SCELBI SOFTWARE BOOKS
... AND SAVE, SAVE, SAVE!
A GREAT BUG-PROOF OFFER!**

HO, HO, HO!

**Save 10% off
Scelbi's newest, hottest
tutorial handbook!**

**Scelbi 8080 Software Gourmet Guide
and Cook Book.** 8080 instruction set.
Programming techniques. I/O
programming using interrupts. Floating
point mathematical package. And
much, much more! Put this one in your
stocking for sure!

**Special Christmas
Sale price . . .**

8⁹⁵



These Christmas Software Sale prices apply only to orders from our North American customers who mention this ad in BYTE. While we wish the best Season's Greetings to our friends around the world, the special paperwork, packing and handling for overseas shipping prohibits our extending these offers outside North America. Sorry.

Companies please note! These special Christmas Software Sale offers apply only to prepaid orders. Purchase orders that require billing services will be billed at regular prices.

Discounts not applicable to prior orders.



**SCELBI COMPUTER
CONSULTING INC.**

1322 Rear Boston Post Road
Milford, CT 06460 • 203/874-1573

Samples of Machine Readable Printed Software

Walter Banks
Computer Communications Network Group
Roger Sanderson
Dept of Electrical Engineering
University of Waterloo
Waterloo, Ontario CANADA

Introducing PAPERBYTESTM

The idea of machine readable software published on paper in a magazine article, book, or pamphlet is a completely new and inexpensive way to mass-produce and distribute software. Since the use of a printing press is nowhere near as labor intensive as technologies such as magnetic recording reproduction, we can build a library of PAPERBYTESTM programs which can be sold quite inexpensively, yet retain a healthy royalty arrangement with program authors. PAPERBYTESTM software packages will consist of optically encoded object text, source listings and complete documentation, marketed through BYTE magazine on a royalty basis. Parties with systems software or applications software potentially marketable to a wide audience via PAPERBYTESTM should explore this possibility by sending a summary of the product, its purpose, and implementation to PAPERBYTES, c/o BYTE magazine, 70 Main St, Peterborough NH 03458. ■

PAPERBYTES, PAPERBITS
are trademarks of BYTE Publications Inc.

One of the papers at the standards session of Personal Computing 76 was our proposal that the popular magazines adopt a printed machine readable standard which would allow programs to be widely distributed. Following the Atlantic City conference the full impact of this proposal has been brought home.

Our initial goal was not to provide yet another mass storage means but to suggest a means of distributing programs through magazines without forcing every reader to retype the program in order to take advantage of it. There is however a second very important reason for adopting some form of printed machine readable code. That is mass distribution of low cost software.

Economically there is no current means by which simple application software (and sophisticated software as well) can be marketed at reasonable cost allowing for author royalties and profits for the publisher, distributor and seller. This is especially true when trying to attract the end user with attractive market prices. The highest cost component of the current most popular method is in the labor cost of cassette tape duplication and the cassette itself.

It is our goal to reduce the duplication costs to that of printed matter but retain the machine readable characteristics essential to successful software marketing and distribution. Bar code in printed form has this characteristic. It can be shown that both printing and reading technology are well

enough advanced to permit acceptable data density and reliable reading.

It is anticipated that both the machine readable code and the accompanying documentation would be printed in booklet form and sold as a complete software package.

At the present time there is considerable evidence that software theft has become a standard rather than exceptional means of software acquisition by individuals. Software theft exists whenever an individual uses a software package created by the mental energies of another, without the author's permission. In the cases where authors have made an honest attempt to provide good software at reasonable prices the inconvenience of ordering it and waiting has often made copies from friends a simpler means of obtaining software. Printed software has the advantage of allowing the normal distribution channels for printed material to service user needs.

There is also a need for a medium which will allow mass distribution of software placed in the public domain. Several institutions and clubs have developed extensive software packages as public service projects, to be made available inexpensively. The requirement is that software be mass duplicated accurately and at low cost. There is a need for this software to be read by a computer employing a reader at low cost.

The last requirement is a scheme which is practical in the user sense. It is essential that the making of the printed master and the reading of the copy be easily accomplished. Printed books and journals are readily reproduced; but they have, for lack of a method, restricted their software distribution to non machine readable forms such as listings or program dumps.

The authors proposed that a simple com-

Made for each other

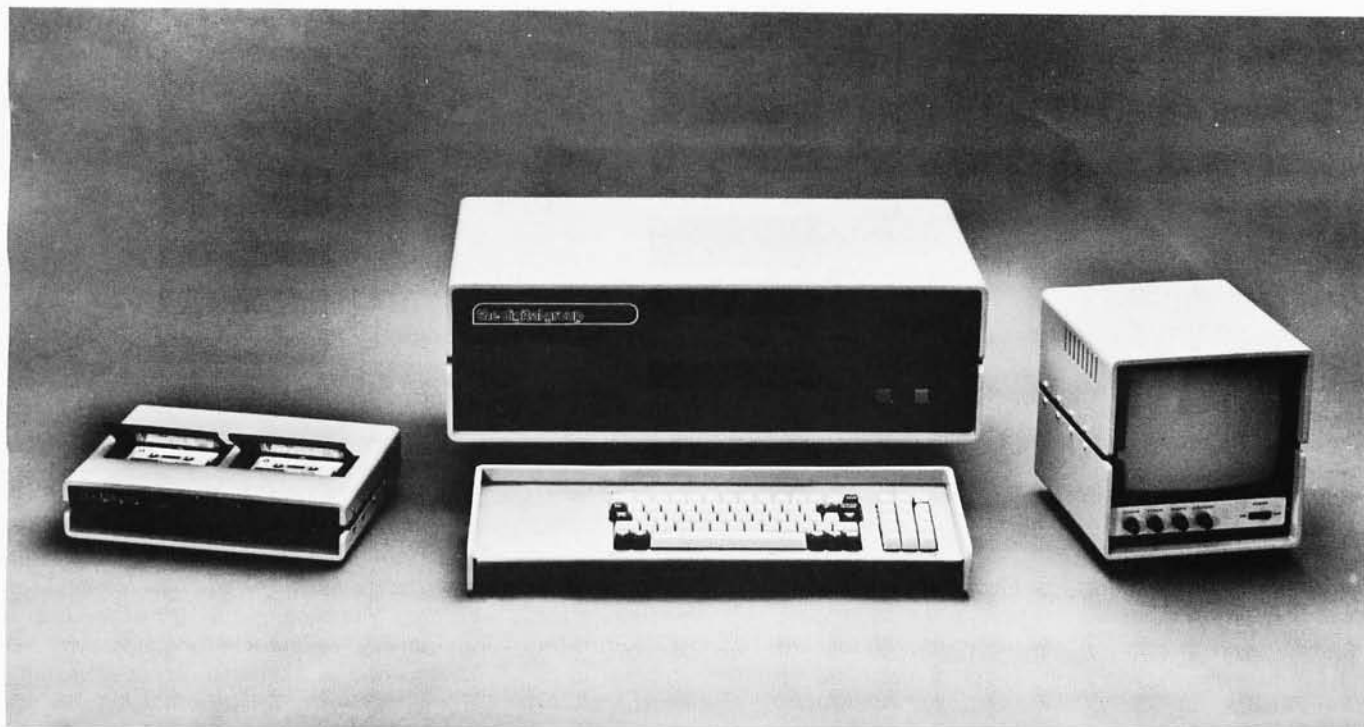

by the Digital Group...who else?

There's a simple reason why a system from the Digital Group looks like it belongs together: It was designed that way. And the look is fantastic.

Each component in our video-based microprocessor system has its own cover-up, designed to compliment every other component. The cabinets are a rugged anodized aluminum (computer beige with chocolate brown) with a unique styling that's ours alone. And, each new product will maintain the same unmistakable Digital Group image.

Inside, things get even better. Digital Group systems are complete and fully featured — the pieces really belong together — so there's no need to purchase bits and pieces from different manufacturers. We have everything you need, but almost any other equipment can be easily supported, too, thanks to the universal nature of our systems.

And, we offer interchangeable CPU's from different manufacturers, including 8080, 6800, 6500 by MOS Tech and the exciting new Z-80 from Zilog. They're all interchangeable at the CPU card level, so you can rest assured your system will always belong together — and it won't become instantly obsolete by new design breakthroughs.

The Digital Group also offers more options, peripherals, expansion capabilities and accessories. They include rapid computer-controlled cassette drives for mass storage, memory, I/O, monitors, prom boards, multiple power supplies, prototyping cards and others. Software packages include BASICs, Assemblers, games, ham radio applications, software training cassettes, system packages and more. All designed to keep Digital Group systems very together.

Our products are made for each other, and they may be made just for you. To find out more, call or write today!

the digital group[™]

P.O. Box 6528 / Denver, Colorado 80206 / (303) 777-7133

Figure 1: Three possible formats. These are proposals at this time, with the appropriate parameters indicated.

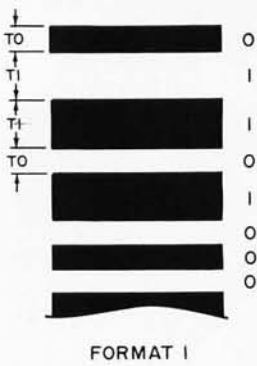

Figure 1a: Format 1: Bar width modulation, with alternate dark and light. The parameters to be specified in printing are widths T_0 and T_1 . A trailing bit complementary to the last data bit in a string is required. The leading bit of a string will be assumed to be in the dark state. In reading this code, time between transitions falls into two categories, long for a 1 bit, and short for a 0 bit.

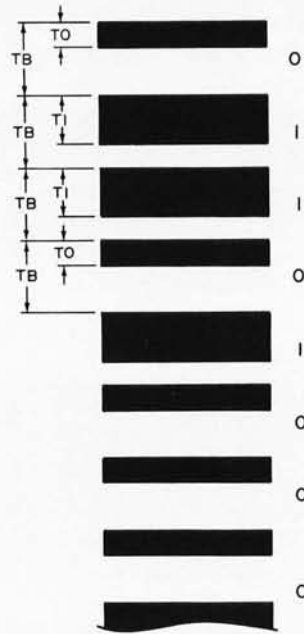

Figure 1b: Format 2: Ratio recording. The parameters to be specified in printing are the bit length, T_B and the T_0 and T_1 widths for states of the data. This format has a fixed length per bit which is independent of the state of the data. In reading this code, the time from one light to dark transition to the next light to dark transition is the duration of the bit cell, which is compared to the duration of the dark period to find out whether a 1 bit (long) or 0 bit (short) was read.

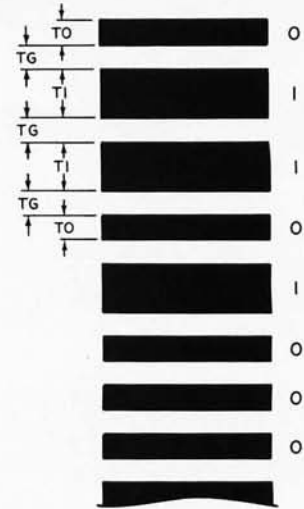

Figure 1c: Format 3: Fixed gap bar width modulation. The parameters to be specified in printing are the interbar gap width T_G , and the bit length parameters T_0 and T_1 . In reading this code, the length of the interbit gap gives a calibration for judging the next dark period as a 0 bit (short) or 1 bit (long). The data density (as in format 1) varies with the statistics of the number of 0s and 1s in a given region of the printed data.

puter readable code be adopted which can be printed by a normal offset press and can be read by an optical reader. Bar code can be typeset by a conventional phototypesetter, driven perhaps by a special program. This scheme is not intended for use by individuals in exchanging software, but it will enable magazines, publishers and larger clubs to provide such services.

Magazines and journals will have at their disposal a means other than printed words of conveying a product of immediately usable value.

In designing the code, we set out to achieve simplicity and reliability. Any bar code that one uses should be self clocking and self calibrating in some manner. If it is to be read with a hand held light pen, it also should be reading-speed independent. A bar code will have to have some error checking mechanism.

There are many ways to generate bar codes; three of the simplest are shown in figure 1.

- Bars which have two widths representing a 0 or 1. This scheme often alternates dark and light bars to represent successive bits. This scheme is quite speed sensitive. It represents a byte which has predominately all 0s in a shorter space than a byte which is predominately all 1s.
- Bars which have two widths representing 0 or 1; however, the space per bit is constant. This code is essentially speed independent.
- The second system can be compressed by making all the light bars equal to the narrow bars in width. It is the function of the light bars to provide a reference for the reader to interpret the data value of the dark bars. With the light bars at constant width this function can still be performed and record length can be saved.

It is this last bar scheme which is being proposed. The data will be represented by

NOTE: Figures 1 to 3 accompanying this article are reprints of the illustrations accompanying the article "A Proposed Standard for Publishing Binary Data in Machine Readable Form" appearing on page 10 of BYTE's November 1976 issue.

Microcomputers are highly complicated devices. When you buy one you want to make sure the manufacturer has a solid reputation for reliability and support. You want to make sure he'll be in your corner a year or two down the road.

The Altair™8800 from MITS was the first general-purpose microcomputer. Today, there are more Altair computers up and running than all the other general-purpose microcomputers combined. Today, Altairs are successfully used for literally hundreds of personal, business, scientific, and industrial applications.

Because we are so popular, many people have tried to copy us. The pages of microcomputer magazines are full of advertisements for Altair compatible devices and Altair imitation computers.

Because we are **NUMBER ONE**, we offer a much broader range of products and services than any of our competitors. One manufacturer might be able to copy one of our computers. Another might be able to produce a working memory card. But no one can copy the overall Altair concept.

The Altair concept is a system concept aimed at practical, cost effective applications. That's why we offer three mainframes including the Altair 680b, Altair 8800a, and Altair 8800b; ten peripherals including a multi-disk system; and over 20 plug compatible modules including our new, low power 16K static memory board. That's why we are the only microcomputer manufacturer to go to the extra expense of providing our customers with quality, higher language software.

When you buy an Altair, you're not just buying a piece of equipment. You're buying years of reliable, low-cost computing. You're buying the support of the **NUMBER ONE** manufacturer in the microcomputer field.



mits

2450 Alamo SE/Albuquerque, NM 87106/505-243-7821

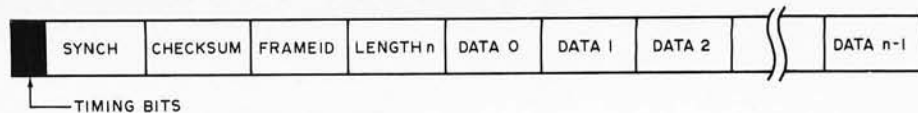

Figure 2: Frame Format. The timing bits may not be required, but provide a preliminary leader before the ASCII SYN character (hexadecimal 16) which leads off the frame. All data is transmitted most significant bit first. Following the synchronization character is an 8 bit checksum representing 2's complement modulo 256 summation of all the remaining data on the record. The FRAMEID field is an 8 bit integer used for relative positioning within an extended file. Its purpose is to allow manual rescan in the event of errors, so that the software will recognize the input as the same record. The length field contains a direct integer value for the number of bytes in the data field. From 1 to 255 bytes can be in the data field; a length of 0 is reserved for a special case "end of file" frame. Finally, the remainder of the frame contains 8 bit bytes of data.

having a 0 displayed as the same width as a light space and a 1 either two or three times as wide. In the examples which accompany this article both types of 1s are shown.

We expect a bar code of this type can be printed and read reasonably using approximately 50 bits to the inch on the average. A conventional magazine page has a working area of 7.0 by 10 inches (17.8 by 25.4 cm). At 5 columns to the inch (2 columns per centimeter) this would give 350 column inches (889 column-centimeters) of bar code or (350 by 50) 17,500 bits per page. Even with losses due to the frame overhead for synchronization and checksums this gives a reasonable amount of code per page, using a layout shown in figure 3.

A simple hand held reader with sufficient logic to tell a computer that it sees light or dark passing is all that is really needed. Fred Merkwitz in his article on page 77 provides examples of typical signal processing circuits needed to convert light and dark image

information into TTL levels for a computer. Software such as is outlined by Keith Regli in his article in this issue would be needed to time the bits and reassemble the data characters. Such a reader should be quite inexpensive to build. A more elaborate version would read a line of bars and indicate if the checksum was correct and pass a line of bytes to a computer.

The record frame (see figure 2) is broken into two parts: a header consisting of four bytes and a data part which may have up to 255 bytes.

The first byte of the header is an ASCII SYN character (10010110). It is to be used by a reader to synchronize on the correct byte boundaries.

The second byte of the header makes the sum of all of the bytes in the record except the SYN character equal to 0. This sum includes the byte count byte, record id, and the data bytes. This is called CHECKSUM byte.

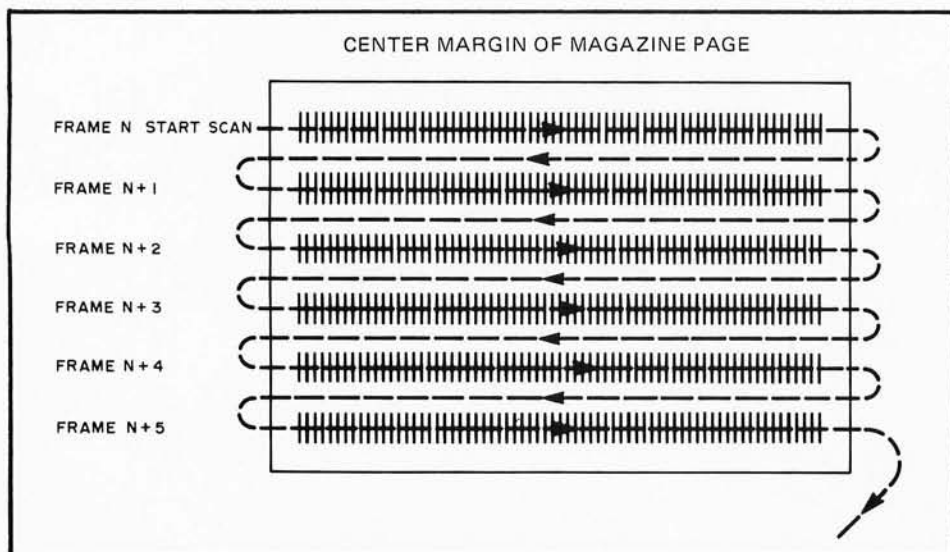

Figure 3: Page Layout. A page of data in printed form [as we would run in BYTE] would be laid out with the data running parallel to the center margin of the magazine. This allows the maximum amount of data in a frame, thus minimizing the overhead bits of the frame format.

Figure 4: A Selection of Bar Code Sample Texts. In each case, the same text is used, an ASCII alphabet. Different data densities are shown to test print reproduction quality. This set of samples should be used by our readers to check out their own experiments with this technology. To read a line of bars place a ruler or other straightedge next to the line, start the input software, then run the optical scanning head (in its simplest form a photodetector and light source) down the line of bars so that the sensitive area of the detector is in the center of the line.

The third byte of the header is a record id number used to identify to the computer the sequence number of the record.

The fourth byte of the header contains a count of the number of bytes in the data portion of the frame. If this byte should be 0 it is interpreted as an end of file record. The data part of the record follows the header.

It should be noted that the last byte of data must be followed by a single data bit, either a 1 or 0, in order to read the last byte of data. This is required to give a light to dark transition after the last data bit of the last byte.

The data portion of a frame is not data sensitive in any way. Here conventional computer standards can be used to format data. In the case of ASCII, data characters can be strung one after another with normal carriage return and line feed characters used to terminate lines quite independent of their position in the frame, or position on the printed page.

Binary data can also be placed in the data area of the frame. As in conventional binary files there is a need for an additional protocol to be used to identify load points and possibly other things like start addresses.

In the samples shown with this article all the records are identical except in density and bit size. In each of the records the ASCII alphabet is used as data. The intent is to provide some copy with which to test experimental readers.

There is a need for a better low cost software distribution means. Personal computing is one of the fastest growing activities today. Distribution of information is extremely important to sustain this growth. We believe this new machine readable method of printing will make a valued contribution to this growth. It is our conclusion that some form of machine readable printed software is the key to wide distribution of software for computer hobbyists. ■

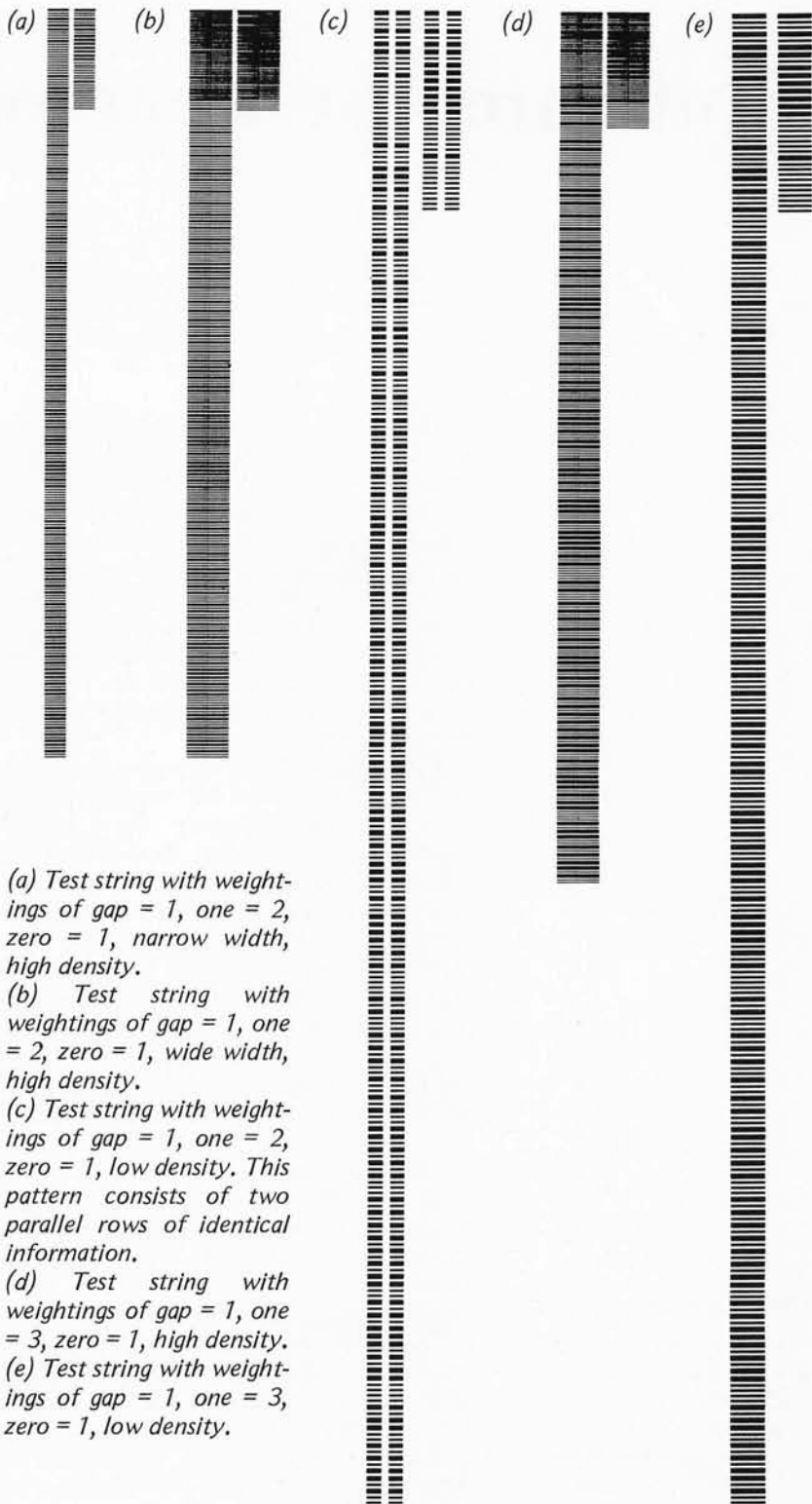

(a) Test string with weightings of gap = 1, one = 2, zero = 1, narrow width, high density.

(b) Test string with weightings of gap = 1, one = 2, zero = 1, wide width, high density.

(c) Test string with weightings of gap = 1, one = 2, zero = 1, low density. This pattern consists of two parallel rows of identical information.

(d) Test string with weightings of gap = 1, one = 3, zero = 1, high density.

(e) Test string with weightings of gap = 1, one = 3, zero = 1, low density.

Software for Reading Bar Codes

Keith Regli
6 Vernon St, Apt 2R
Waltham MA 02154

The problem of transferring programs and data from one computer system to another has long been a problem in industry, but for the hobbyist it is especially difficult. Paper tape and cassettes have solved the problem for communication between individuals, but what about a program published in BYTE magazine? Keying in a hexadecimal listing is painful and error prone, and machine readable forms such as phonograph record inserts are too expensive for regular use. A possible solution is at hand!

Bar codes are gaining increasing acceptance in industry for transmission of machine readable information via a printed medium. The technology which makes this possible is the microprocessor. While most industrial and commercial bar codes contain 40 bits of information or less, there is no reason we can't scan enough information in one pass to make the transmission of long programs a snap.

In this article I will discuss some algorithms for reading bar codes which are adaptable to any of the popular microprocessors assuming suitable input signal conditioning hardware. While translating these algorithms directly into code will produce a working system, they should be thought of as a starting point for experimentation.

There are many ways in which to design a bar code. We will use a simple but effective method of dealing with binary information. Each bit of information will consist of a dark bar followed by a white space, the combination being called a module. We represent a 1 by a module consisting of a bar twice as wide as its space and a 0 by a module consisting of a bar the same width as the space. Eight such modules strung together give one byte of information. If we made the width of a space 0.01 inches (0.25 mm) we could get about 5 bytes per inch (about 2 bytes per centimeter) — this allows plenty of

information to be printed on one magazine page, as Walter Banks and Roger Sanderson point out in their article.

In order to see what it takes to read information in this form consider a paper tape system. There is a read head which senses the coded information, a hardware (or software) code converter which converts the sensed information into a form suitable for a loader which loads the information into the computer's memory at appropriate locations. We need exactly the same elements in order to read bar codes. The "read head," called a scanner, and its electronics are discussed in some detail in Fred Merkwitz's article and are not repeated here. Loaders are fairly well understood, but the code conversion process is not nearly so widely understood and thus commands the main emphasis of this article.

There are two approaches one may take for inputting the data in a microprocessor controlled code converter. The data may be processed as it is read in, or it may be read first and then processed after the data is in memory. The critical factor is how many instructions the processor can execute between data samplings. In order to keep things simple we will not plan to do any processing on the fly. Suppose that the average scanning rate is 20 inches per second (51 cm per second) and the basic element width is 0.01 inches (0.25 mm). Then we see one basic element every 500 μ s. Now, if we increment a counter every 20 μ s and read it every time our scanner detects a transition from light to dark or dark to light we will get a nominal count of 25 for each basic element. The readings for our standard modules would be 50/25 for a binary 1 and 25/25 for a binary 0. This means that we are well within 8 bits while counting a double width element, even at a slow scanning rate of 10 inches per second (25 cm per second). Assuming 50 bytes of data on one reading pass, we will need 800 bytes of memory to store a perfectly read image of the code as a series of counts. Assuming a few white and black specks on a line we should leave at least a 1 K buffer size for reading in a line of

About the Author

Keith Regli is employed as a programmer at Electronics Corp of America, Cambridge MA. He writes from professional experience with the adaptive software necessary to read bar codes in commercial and industrial applications. His avocational interests in addition to computers include amateur radio (WB6BIG/WA1WOE).

code (if we can do a little filtering on the fly or in the hardware, we can push it back to around 800 bytes).

The algorithm for inputting a line of coded bars becomes very simple in this scheme.

SCAN Program:

- 0) Set the buffer pointer and the counter to zero.
- 1) At the next 20 μ s interrupt, continue.
- 2) Has the counter reached 255? If YES then test and go to processing routine (step 4). If NO then increment the counter and continue.
- 3) Has the level of the input changed? If YES then store counter value at buffer pointer location, increment the buffer pointer, set the counter to zero and go to step 1. If NO then return to step 1.
- 4) Is buffer pointer equal to 0? If YES then return to step 0. If NO then jump to processing routine.

INTERRUPT SERVICE ROUTINE

We may, of course, replace the interrupt by adding some do nothing states so that the service routine requires 20 μ s no matter which way we go through it, and so that it operates as a scanning loop. (The 20 μ s interval is not sacred; 18, 21, 32 or 50 μ s will do).

The next thing to do is process our buffer trying to pick out bytes of data which can be loaded into memory. If we have been very lucky, each pair of bytes in our buffer represents one bit of data. However, Murphy is a part of life and we must expect dust specks and other noise to get in and make some sort of filtering necessary. A simple scheme is to ask if the next count is more than one fourth (shift right twice) the last count. If the answer is yes we have a valid count, but if the answer is no we assume it was a dirt speck and combine the last count, the next count and the one after that as a replacement for the last count. Murphy has at least one other trick up his sleeve. If you take a bar 0.01 inches (0.25 mm) wide and put it next to a space 0.01 inches wide and then scan the pair at a constant rate, you will almost certainly find that the scanner thinks the bar is wider. This can be taken care of by adding a bias to the space count.

For convenience we will convert the input buffer into bytes of data and store them in a line buffer before passing them to the loader. We need a line buffer of

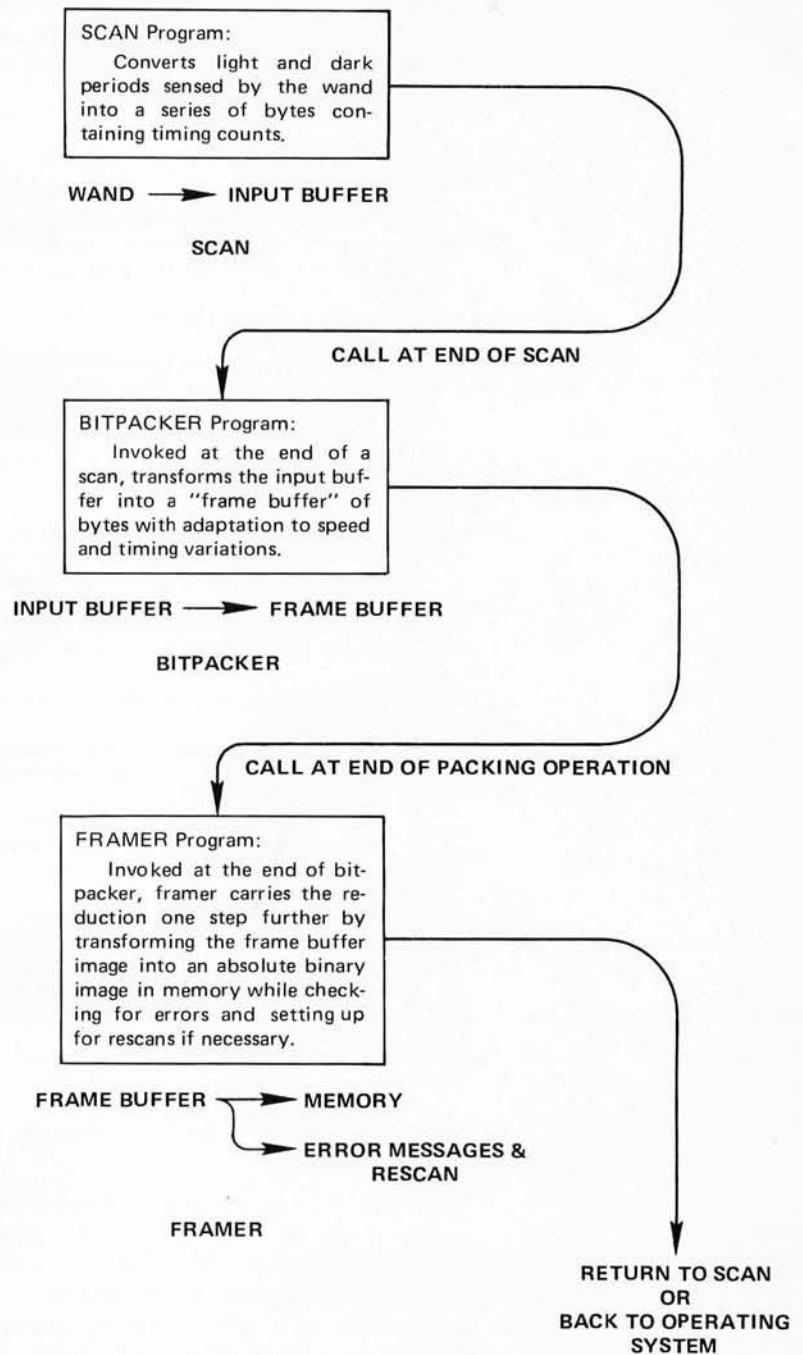

Figure 1: Software Structure. The design of the scan conversion software presented in this article contains three major program components. The SCAN program is an interrupt handler (or dedicated scanning loop if you don't use interrupts) which creates an INPUT BUFFER of integer time count values for alternating black and white zones sensed from the manual scanner. The BITPACKER program carries the conversion further by reducing the 16 bits (on the average) of count information for each bit into a single bit within a string of bytes in the FRAME BUFFER. Finally, the FRAMER program transfers the contents of the FRAME BUFFER to memory, checking the checksum information and giving error messages if needed. Structuring the software in this way makes it easy to isolate and experiment with the functions. The timing requirements of the input scanning operation require that SCAN be separate process; an alternate configuration in which BITPACKER and FRAMER are combined in one pass is quite possible.

50 bytes, an input buffer pointer, a line buffer pointer, a bias value, a bar count, a space count and a basic unit count. We can now describe the algorithm for converting an input buffer to a line buffer.

BITPACKER Program:

- 0) Set the input buffer pointer and the line buffer pointer to zero, and set the basic unit count to 25. (A nominal starting value.)
- 1) Set the bar count and the space count to zero.
- 2) Have we reached the end of the input buffer?
 - If YES then jump to the loader routine.
 - If NO then load the next input buffer position into the bar count and increment the input buffer pointer.
- 3) Is the bar count greater than one fourth the current basic unit count?
 - If YES then continue to step 4.
 - If NO then add the next two buffer positions to the bar count, increment the buffer pointer twice, check for the end of buffer and resume at step 3.
- 4) Repeat step 3, but filling the space count.
- 5) Add the current bias value to the space count.
- 6) Is the bar count greater than 1.5 times the space count?
 - If YES then set the next bit in the current line buffer word (after 8 bits increment line buffer pointer), set the basic element count equal to $(\text{basic element count} + \text{bar count} + \text{space count})/4$, set the bias equal to $((\text{bar count})/2) - \text{space count} + 2*\text{bias}/2$
 - If NO then leave the next bit in the current line buffer word cleared (after 8 bits increment the line buffer pointer), set the basic element count equal to $(\text{basic element count} + (\text{bar count} + \text{space count})/2)/2$, set the bias equal to $(\text{bar count} - \text{space count} + 2*\text{bias})/2$
- 7) Return to step 1.

Bar Codes and Morse Codes

Author Regli made an interesting comment on his author's proof copy of this article: The problem of decoding optical bar codes is entirely analogous to the problem of decoding Morse code as described in BYTE's October issue. In fact, it is simpler and more reliable, for while the speed varies, the local ratios of bar lengths are always "perfect" due to the fact that the typesetting and printing process fixes these ratios. Thus for detailed software ideas consult BYTE's October issue.

In order to load the line into memory as usable codes we must process the frame format for the input line. There are many variations, but all contain basically the same information — a sync character, a checksum, a base address and a length. In our case the base address is not encoded in the frame format, and is replaced by a line number which is used to determine whether a frame has been repeated. The actual memory pointer is maintained separately by the decoding software and is incremented as each byte is decoded. The decoding algorithm for the format described by Banks et al [given on page 12, figure 2 in BYTE's November 1976 issue and page 14 of this issue] is as follows when specified in verbal pseudo code:

FRAMER Program

- 0) Obtain the start address from the user and set the next free address to that value.

- 1) Set the line buffer pointer to zero.
- 2) Have we reached the end of line buffer?
 - If YES then get set to scan the next line (step 14).
 - If NO then continue to the next step.
- 3) Is the next BYTE the sync character?
 - If YES then continue to the next step.
 - If NO then increment the line buffer pointer and return to step 2.
- 4) Increment the line buffer pointer, load the two's complement of the next byte into the checksum location.
- 5) Increment the line buffer pointer and load the next byte into the line id location, add this byte to the checksum. If this is a repeat scan, then back up all pointers to repeat the erroneous load attempt.
- 6) Increment the line buffer pointer and load the next byte into the line length location, add this byte to the checksum.
- 7) Are the line length and the line buffer length consistent?
 - If YES then save the line buffer pointer and continue.
 - If NO then jump to the error on read, step 13.
- 8) Increment the line buffer pointer and add the next byte to the checksum. Decrement the line length.
- 9) Is the line length zero?
 - If YES then continue to the next step.
 - If NO then return to step 8.
- 10) Is the checksum zero?
 - If YES then set the line buffer pointer to the value saved in step 7. Load the next byte into the line length location and continue.
 - If NO then jump to the error on read, step 13.
- 11) Increment the line buffer pointer, load the next byte at the next free address pointer, increment the next free address pointer and decrement the line length.
- 12) Is the line length zero?
 - If YES then jump to step 14.
 - If NO then return to step 11.
- 13) Report a read error and the line number, set up for repeat scan.
- 14) Report ready for next scan and return to the scanning routine.

These algorithms, specified in pseudo code, are but a simplified first pass through the problem. Figure 1 summarizes the structure of the software. These routines should prove sufficient to read the bar codes into your computer given processing front end hardware and optics sufficient to resolve the light and dark states of the code. More elaborate adaptive algorithms are of course possible, but with the software specified above it should be possible to read the codes. Further work is certainly needed in the area of defining the data formats within the raw byte capacity of the frame, and for the moment we assume that an application program or a system program (such as a relocating linkage editor) knows what to do with the data if it is not an absolute binary memory image for a machine language program which can be executed once it is in place. ■

We've got it! Z-80 power for the Altair bus.

Here it is, TDL's ZPU™ the highest point of technology for an Altair/IMSAI system. Now, you can multiply your present capabilities without creating costly obsolescence. Take advantage of the wide range of existing hardware backup for your current system. The ZPU is compatible and dependable with many plus features you'll want to know about.

To further round out your system we also have available the fastest and lowest power static ram boards going (from 4 to 16K with expansion) and a system monitor board with a Z-80 monitor, powerful I/O and audio cassette features.

As for software, TDL's user support program is unmatched in the micro-processor industry, currently available are the Z-80 monitor, basic, and the most sophisticated MACRO-ASSEMBLER yet developed.

**Join the Z-80 revolution —
it's more than just hardware!**

ZPU Kit \$269.00
Z16K Kit \$574.00

HOW TO ORDER Just send check or money order, or use your BankAmericard or Mastercharge, and your orders will be shipped to you postpaid. COD orders must be accompanied by a 25% deposit. Your credit card order must include the serial # of the card, expiration date, and your order must be signed. New Jersey residents add 5% state sales tax. For more information, send for our free catalog.

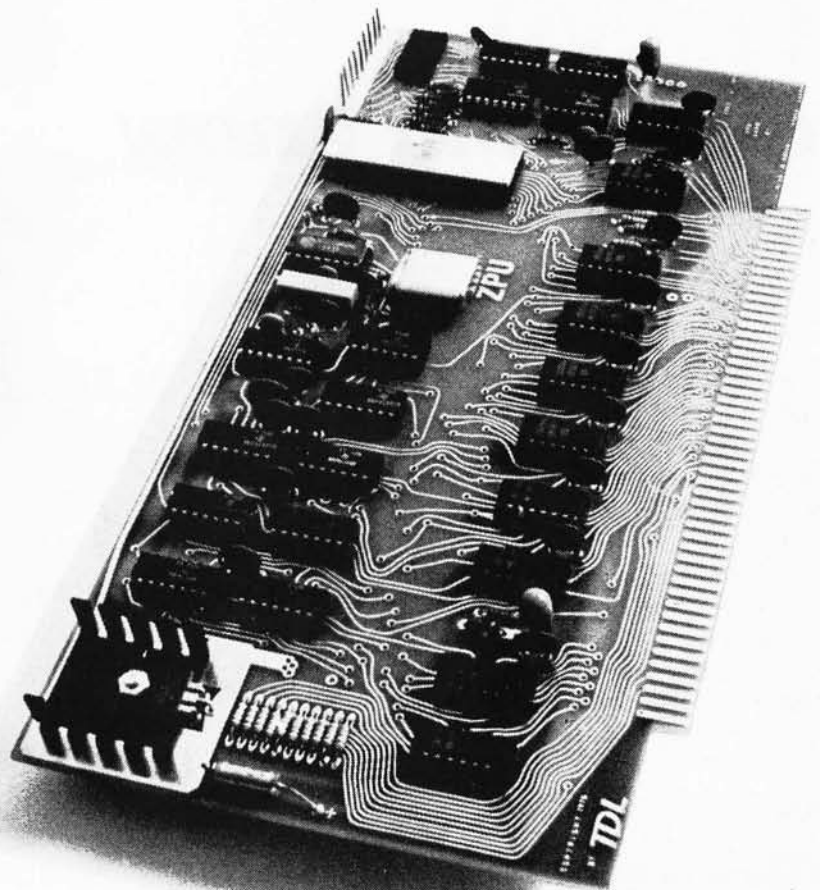

Dealer Inquiries Invited.

TDL

609-921-0321

Research Park
Bldg. H
1101 State Rd.
Princeton NJ 08540

There's another side of IMSAI you should know

Sure you know our IMSAI 8080 computer. Its size, quality, performance and price set the industry standard for value. There's another, equally important side of IMSAI—our broad and ever growing I/O product line. Right now IMSAI offers an array of sensibly priced, versatile, high-quality interfaces and peripherals that live up to the IMSAI 8080 for quality, technical leadership, and value.

IMSAI VIDEO DISPLAY. We call it the most powerful, flexible video display interface available. With up to 3 boards that fit into your IMSAI you can display color characters and color graphics simultaneously. • Unlimited image control. • Large capacity display. • Eight colors; 7 half tones. • All cables included. • Full ASCII character set. • Character blink, reverse video, multiple cursor and double-width characters.

IMSAI KEYBOARD. 53-key, ASCII encoded keyboard with good touch quality and upper case alphanumeric keys that duplicate functions of the ASR-33. Supplied with commercial grade cabinet and cable. Interfaces to any 8-bit parallel port.

IMSAI 44 COLUMN PRINTER. 44 column dot matrix printer offering hard copy output at an affordable price. Interfaces to many computers using an 8-bit parallel output port. Simple programming and installation. Self-contained with case, cable, power supply, timing, control and character generation included. Produces 75/lines/min.; double size characters software selectable.

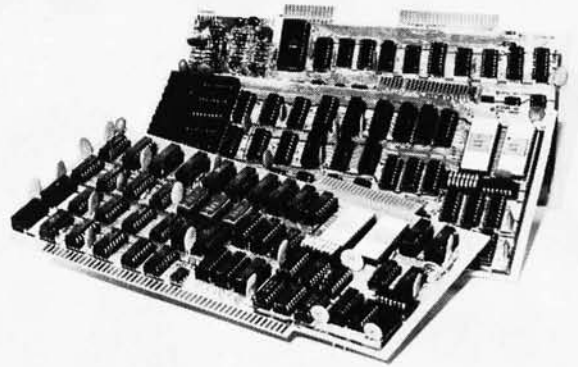

IMSAI VIDEO DISPLAY
Assembled \$1199.00/Unassembled \$699.00

IMSAI MULTIPLE I/O BOARD
Assembled \$350.00/Unassembled \$195.00

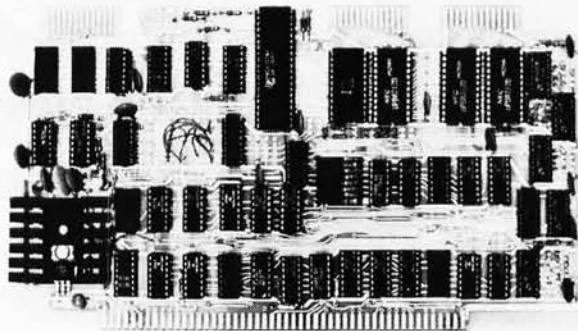

IMSAI MULTIPLE I/O BOARD. Simultaneous control of keyboard, printer, tape cassette (Byte or Tarbell) and teletype (or CRT) by a single MIO board. Our 5-port, multiple I/O board combines the most commonly used I/O interfaces including a cassette interface, two parallel I/O ports, one serial channel and one control port—all on one board!

And many other **IMSAI** I/O interfaces to expand your system. Examples:

IMSAI Programmable Parallel I/O board offering 6-ports for the ultimate in I/O flexibility and control.

IMSAI PRINTER
Assembled \$549.00/Unassembled \$399.00

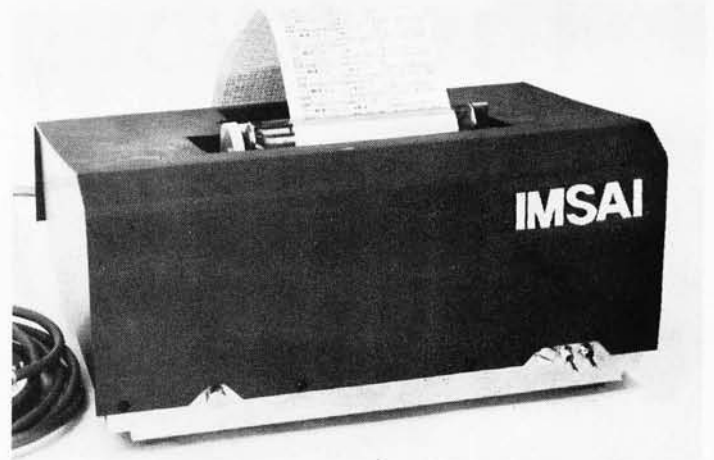

IMSAI KEYBOARD
Assembled \$199.00



IMSAI 2-Channel serial I/O board with 3 modes for total versatility in communications.

IMSAI 4-Port Parallel I/O board with LEDs for visual observation of data flow.

IMSAI Intelligent Bread-board for easier, more accurate circuit design and classroom instruction.

IMSAI 4K RAM—the best price performance 4K RAM board on the market.

Socket sets for all boards. Use for easier board maintenance.

For commercial application—Our IMSAI floppy disc with disc operating system and extended BASIC.

ALL these IMSAI products available NOW at your IMSAI dealer or from the factory.

Yes, the other side of IMSAI has much to offer. It's a complete I/O line with products that match the IMSAI 8080. We offer a detailed, illustrated catalog describing the IMSAI 8080, its options, peripherals, software, prices and specifications. Send one dollar to cover handling. Write or call for name of the nearest dealer.

Dealer inquiries invited.

For more information circle A 12.

IMSAI

IMSAI Manufacturing Corp.
14680 Wicks Boulevard
San Leandro, CA. 94577
(415) 483-2093
TWX: 910-366-7287

The Cybernetic Crayon



A Low Cost Approach to Human Interaction with Color Graphics

Thomas A Dwyer
Leon Sweer
Soloworks Lab
University of Pittsburgh
Pittsburgh PA 15260

The Cromemco TV Dazzler (described in BYTE No. 10, June 1976, page 6) is one of the most interesting (as well as economical) peripherals available for displaying computer output. It literally puts a picture of what's in your computer's memory on a home color TV set. The simplicity of this idea cuts through all the complexities that expensive color graphics systems (some costing over \$100,000) have presented to "ordinary" computer users in the past. The potential applications of low cost color graphics, especially in learning environments of the type we have been developing at Soloworks [*The Soloworks lab is concerned with using computers in education as tools for supporting student creativity. A newsletter describing the project is available from author Dwyer.*], are almost endless.

At the present time there are two obstacles to using the Dazzler to its full potential. The first is difficulty in programming. Most

users find it inhibiting to work at the machine language (or even assembly language) level. There isn't any doubt that color graphics will really take off in educational and home computing when simple user oriented graphic instructions become available in higher level languages like BASIC.

The second problem that needs to be attacked is the lack of human-oriented input devices that allow one to interactively "play" with color graphics. It is of course impressive to see what a clever programmer can do by loading in carefully written machine language graphics demonstrations. But the real future is in making computers responsive to control actions that mirror the "macro" ideas of human imagination and even fantasy. It's the difference between sitting in the back of an airplane admiring how clever your captain is, and moving into the pilot's seat with a chance to do a few lazy eights around the sky yourself.

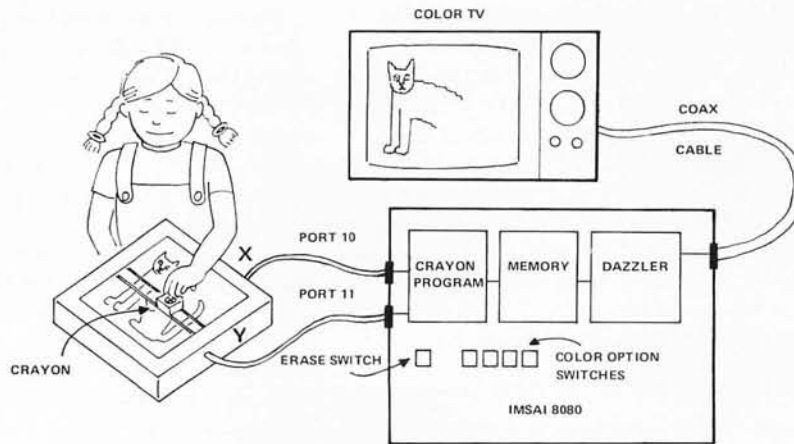

Figure 1: The Cybernetic Crayon System. The XY digitizer position is set by the young artist, and interpreted by the 8080 processor running a program shown in Listing 1. This program uses the position information along with the settings of front panel switches to determine the color value of each position in the picture as it is drawn.

Graphics Software

Some of the people at Dartmouth (Arthur Luehrmann in particular) are working at defining a set of graphic extensions for the language BASIC. This is a good idea, but it's slow work. Getting different groups with different interests to agree on anything is pretty difficult. We'll be following this activity at Soloworks, and may try extending one of the microcomputer versions of BASIC in this direction. In the meantime, we think much attention also needs to be given to *what* people may want to do with graphics, especially the low cost type.

One way to do this is to "imagine" something you'd like to do, and also "imagine" a language for instructing the computer to do this. You can then try to write subroutines in assembly language to implement these macro instructions. True, that's hard work, but eventually the detailed code could be hidden from the user (possibly in BASIC, or possibly in ROM). Then programmers (including young children) could do most of their thinking at the higher level.

Let's illustrate this idea by looking at a first attempt we made along these lines in defining what we call our "cybernetic crayon box." We had lots of ambitious ideas for using the Dazzler, but decided to start very simply. Our thinking was that new features could then be added one at a time in the form of additional subroutines. In other words, the approach we took was to build a total system from what are usually called program "modules." (It's worth noting that this is a good idea for most large programs where clarity is essential. In fact it's the basic idea behind the new rage for what is called "structured programming.")

The Cybernetic Crayon Idea

Let's imagine that we want to make the system of figure 1 possible. The idea is that it would be neat if a child could move some kind of electronic "crayon" around and experiment with drawing colored pictures on a TV screen. In the back of our heads was the thought that it would be even neater if a "big" child (guess who) could drive a spaceship around a full color galaxy in some futuristic Star Trek type game.

Let's imagine a computer program to do this using an imaginary high level language. It might look like the following:

1. Turn on the Dazzler and start displaying memory.
2. If desired, erase memory (to get a blank screen).
3. Look at where the crayon is pointed.
4. See what color it is.
5. Decode this information into proper machine language.
6. Now put information into the computer's memory for display.
7. Go back to step 3.

The "hardest" parts are steps 2, 3, 5, and 6. We decided to make step 3 "easy" by using a special piece of hardware, an \$80 surplus XY digitizer which was sold by Delta Electronics Co (their ad appeared in the May 1976 issue of BYTE). Steps 2, 5, and 6 were handled by software subroutines that can be thought of as simulating macro instructions. Let's look at each of these four steps in further detail.

Using an XY Digitizer as the Crayon

There are several options for the "crayon." One would be a light pen. Another would be a two axis joystick. The

third possibility is to use what's called an XY digitizer. All of these devices can be expensive, since they usually require special interfacing electronics. The exception to this rule is when the devices produce digital data directly, either through brush type contacts or optical disks that control the light falling on photo electric cells. We chose to use an XY digitizer with brush contacts, partly because it was available as surplus, and partly because the XY frame of reference looked like a good way to help even very young students learn about Cartesian coordinate systems (more about this later).

How the Digitizer Works: the Gray Code

The digitizer is a mechanical device which works something like a plotter in reverse. When the user moves the pointer (what we call the crayon), this moves two sets of contacts to positions corresponding to the X and Y coordinates of the crayon. These brushes slide across metal templates that look something like the pattern in figure 2.

The output for each coordinate is a 7 bit binary number. This means that 128 values (2^{*7}) for each coordinate are possible. Each output can be connected directly to one 8 bit parallel input port of your micro-computer. The way the digitizer is wired, each bit that is enabled by the digitizer (that is, contacted by a brush) is grounded. Therefore it is necessary to complement the number read from the port before further

processing. Thus the input pattern (1, 1, 0, 1, 0, 0, 1) becomes (0, 0, 1, 0, 1, 1, 0).

The second trick to using this particular digitizer involves decoding the patterns used on the templates for representing X (and Y) positions. Instead of using a standard incrementing binary code to represent values for X and Y, the digitizer templates use what's called a Gray code. The way that this code represents the X and Y positions between 0 and 127 is shown in figure 2. One may ask, why not use a standard binary code instead of this "strange" version? The reason becomes apparent when one examines each successive number representation. Note that only one bit ever changes between two consecutive positions (or numbers). On the other hand, if the conventional form of binary code were used, many instances would occur in which several bits would have to change at once. (eg: 0111 to 1000 for 7 to 8). This must be avoided because it would be impossible for a low cost mechanical device to succeed in changing all the bits at exactly the same time. Instead, the computer (being as obedient as it is) would read incorrect values as the bits changed. Use of the Gray code solves this problem, but requires that some means be used to translate back into the standard binary code expected by your computer.

The following algorithm will translate the Gray coded numbers into standard binary codes. An example helps to illustrate.

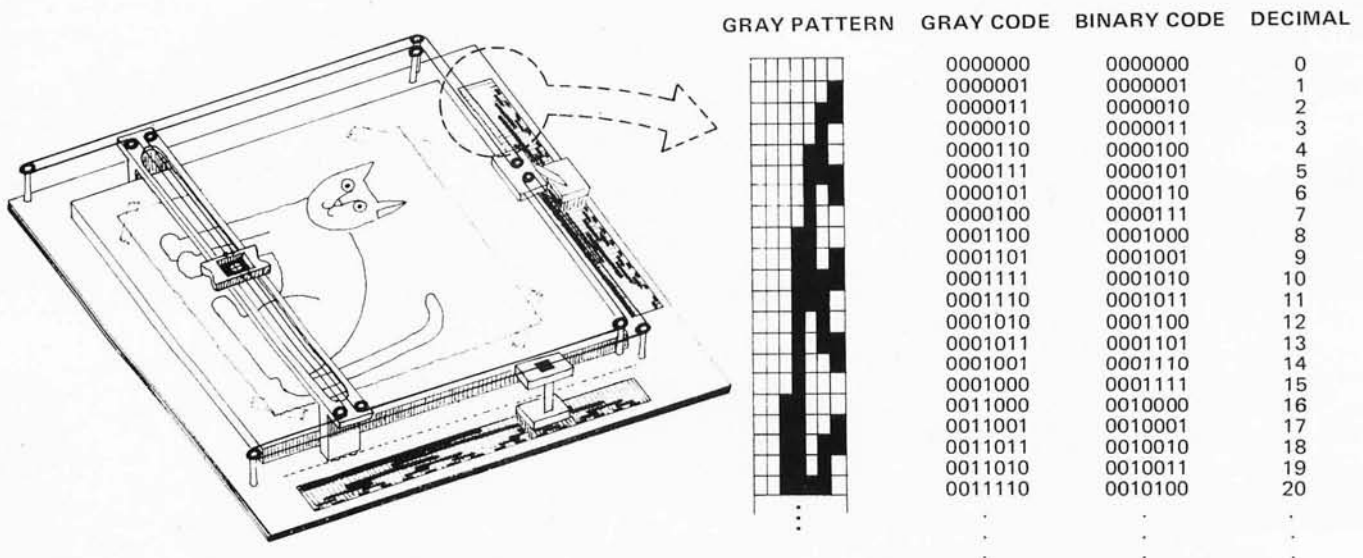

Figure 2: Detail of the Cybernetic Crayon's Surplus Digitizer. The rough artwork of an image may be drawn on paper, or the image can be created without such a layout. The Gray code pattern of the inputs can be seen in diagram form and equivalent binary form at the right.

Problem: Change Gray code 0110100 into a standard 7 bit binary code.

Step	Example (in the example, x's indicate bits yet to be determined, initially zero.)
1. Look at the high order (left most) bit first.	Bit is 0
2. Is the exclusive or (XOR) of this bit and all bits to its left 1?	No
3. Put a 0 in the high order bit of a "running total" RT.	RT = 0xxxxxx
4. Look at next bit.	1
5. Is the XOR of this bit and all bits to its left 1?	Yes
6. Then put a 1 bit in RT on right.	RT = 01xxxxx
7. Look at next bit.	1
8. Is the XOR of this bit and all bits to its left 1?	No
9. Put a 0 bit in RT on right.	RT = 010xxxx
10. Look at next bit.	0
11. Continue until finished.	etc.

Using this algorithm, you can see that 0110100 decodes at the test with exclusive OR to (NO, YES, NO, NO, YES, YES, YES), that is, to 0100111 (which is decimal 39). It is fairly easy to write a program for an 8080 or any other processor which does this, and it is shown in listing 1, relative addresses 004D to 0066. It will be part of our final crayon program. The variable C is where RT is kept in binary form, using the trick of putting higher order bits in at the right, and then shifting them (rotating) to the left until 7 bits have been accumulated. The Gray code is in A at the start.

```

; ROUTINE TO DECODE GRAY CODE
DECODE: MVI C,0 ;CLEAR REG. C
        MOV D,C
        MVI E,7 ;INITIALIZE LOOP
        MOV B,A ;PUT GRAY CODE IN B
LOOP:   MOV A,C
        RLC ;ROTATE C LEFT
        MOV C,A
        MOV A,B
        RLC ;ROTATE B LEFT
        MOV B,A
        ANI 80H ;MASK ALL BUT MSB
        RLC ;PUT MSB IN LSB
        XRA D ;XOR IT WITH ALL HIGHER ORDER BITS
        MOV D,A ;REPLACE RESULT
        ADD C ;PLACE IN LSB OF C
        MOV C,A

```

```

DCR E ;COUNT DOWN LOOP
MOV A,E
JNZ LOOP
MOV A,C ;PUT BINARY CODE IN A
RET

```

A Subroutine for Erasing Memory

If we want to draw a picture in the "memory space" of our computer, the first thing we may want to do is erase the space. This is accomplished simply by writing zeros in each location. The routine in listing 1, relative addresses 009B to 0048, erases memory, beginning at the location specified in the 8080's HL register pair, and erases a number of locations equal to 256 times the number in the A register. (It's a good idea to keep subroutines such as this as general as possible when developing flexible software.)

```

;ROUTINE TO ERASE 256*A BYTES STARTING AT H,L
ERASE: MVI D,0 ;CLEAR D,E
        MOV E,D
        MVI M,0
NEXT:  INX H ;ADVANCE POINTER
        MVI M,0 ;CLEAR THAT BYTE
        INX D ;INCREMENT COUNTER
        CMP D ;SEE IF A BYTES WRITTEN
        JNZ NEXT ;IF NOT, GO BACK
        RET
        END

```

It will be seen later (in the main program) that the erase routine is called by flipping the left most switch of the "programmed input" register on the IMSAI front panel.

A Subroutine for Mapping XY Coordinates Into Memory

Before showing how to translate (or "map") the decoded X and Y values into a memory location to be used as part of our TV picture, it is useful to understand how the Dazzler works. In particular, we want to know something about how it interprets a block of memory and translates it into a color TV picture element.

The Dazzler uses two output ports of the microcomputer. Through these two ports, the computer tells the Dazzler whether to turn itself on, where in memory the picture begins, how many bytes the picture comprises (the choices are 512 or 2048), and what type of picture (color and resolution) should be displayed on the TV. The output to the TV comes directly from the Dazzler.

Figure 3: Color Command Word of the TV Dazzler. This is the layout of each 4 bit nybble in the color display memory region of 2048 bytes.

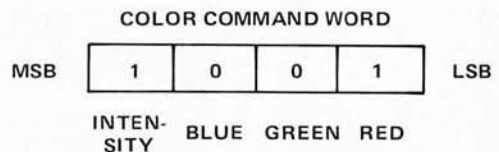

LOCATIONS RELATIVE TO STARTING LOCATION

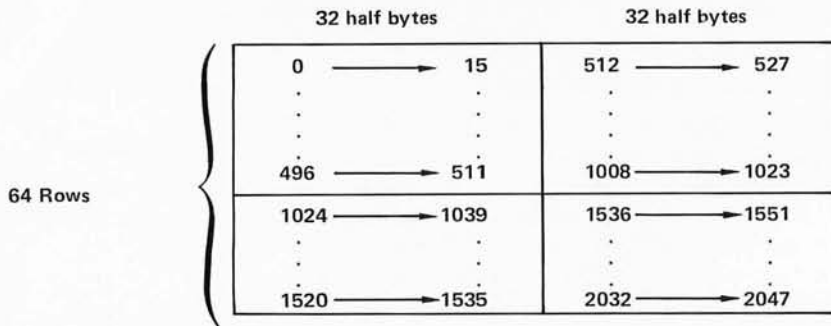

Figure 4: Memory Map of the Dazzler Peripheral. This map correlates the displayed picture to the array of memory bytes. The addresses are indicated here in decimal.

Listing 1: The Cybernetic Crayon Program. This shows the complete assembly listing (relative to address 0). The major subroutines discussed separately in text are the gray code conversion routine DECOD, the memory clearing ERASE, and the address calculation routine TRANS.

```

0000      ;MAIN PROGRAM                               16
0000      ORG      0
0000 3E 88      MVI    A,88H      ;TURN ON DAZZLER
0002 D3 16      OUT    16H      ; -
0004 3E 30      MVI    A,30H      ; -
0006 D3 17      OUT    17H      ; -
0008 31 EF 00   LXI    SP,0EFH    ; SET STACK POINTER
000B DB FF      INPUT: IN     0FFH    ;GET SWITCHES
000D 17         RAL          ;CHECK FOR MSB
000E D2 19 00   JNC    NOERS    ;IF NOT SET, GO GET POINTS
0011 21 00 10   LXI    H,1000H    ;IF SET, LOAD H,L AND A
0014 3E 08      MVI    A,08H      ;AND CALL ERASE
0016 CD 9B 00   CALL   ERASE
0019 DB 10      NOERS: IN     10H      ;GET X DATA FROM CODER
001B 2F         CMA          ;COMPLEMENT X
001C CD 4D 00   CALL   DECOD    ;TRANSLATE X INTO BINARY
001F 67         MOV    H,A      ;SAVE X
0020 DB 11      IN     11H      ;GET Y DATA FROM CODER
0022 2F         CMA          ;COMPLEMENT Y
0023 CD 4D 00   CALL   DECOD    ;TRANSLATE Y INTO BINARY
0026 4F         MOV    C,A      ;SAVE Y
0027 44         MOV    B,H      ;PUT X IN B
0028 1E 10      MVI    E,10H    ;LOAD HIGH ORDER STARTING ADD OF PIC
002A CD 67 00   CALL   TRANS    ;TRANSLATE INTO MEMORY ADDRESS
002D DB FF      IN     0FFH    ;READ SWITCH REGISTER
002F E6 0F      ANI    0FH      ;SCREEN OUT OTHER SWITCHES
0031 4F         MOV    C,A      ;SAVE SWITCH REGISTER
0032 3E 00      MVI    A,0      ;IF REGISTER D=0
0034 BA        CMP    D      ; -
0035 CA 45 00   JZ     SNOT     ;THEN GOTO SNOT
0038 79         MOV    A,C      ;GET SWITCH REGISTER
0039 07         RLC          ;SHIFT LEFT 4 BITS
003A 07         RLC
003B 07         RLC
003C 07         RLC
003D 4F         MOV    C,A      ;RETURN TO C
003E 7E         MOV    A,M      ;GET OLD WORD IN DESIRED LOC
003F E6 0F      ANI    0FH      ;GET RID OF THIS HALF
0041 B1         ORA    C      ;PUT IN NEW GROUP
0042 C3 49 00   JMP    STUFF
0045 7E         MOV    A,M      ;GET OLD WD IN DESIRED LOC
0046 E6 F0      ANI    0F0H    ;GET RID OF HALF
0048 B1         ORA    C      ;PUT IN NEW GROUP
0049 77         MOV    M,A      ;WRITE NEW WORD IN M
004A C3 0B 00   JMP    INPUT    ;GET ANOTHER POINT
004D          ;
004D          ; ROUTINE TO DECODE GRAY CODE
004D 0E 00      DECOD: MVI    C,0      ;CLEAR REG. C
004F 51         MOV    D,C
0050 1E 07      MVI    E,7      ;INITIALIZE LOOP
0052 47         MOV    B,A      ;PUT GRAY CODE IN B
0053 79         LOOP: MOV    A,C
0054 07         RLC          ;ROTATE C LEFT
0055 4F         MOV    C,A
0056 78         MOV    A,B
0057 07         RLC          ;ROTATE B LEFT
0058 47         MOV    B,A

```

All these functions are represented on the output ports of the IMSAI 8080 we used, as follows:

Port 16: Bits 0 to 6 contain the most significant 7 bits of the starting picture address. Note that only multiples of 512 are possible.

Port 17: Bit 6 is a resolution multiple of 4 if on, normal if off.

Bit 5 is a picture in 2 K bytes of memory if on, 512 bytes if off.

Bit 4 is a color picture if on, black and white picture if off.

Bits 0 to 3 are intensity and color bits used only in high resolution mode. We will not be concerned with these 4 bits.

It is not necessary to understand all of these options and modes to use the Cybernetic Crayon. We will therefore concentrate on the mode in which 2 K of memory is used, and in which each byte represents two picture elements (small rectangles). In this mode, the picture is composed of 4098 (64 by 64) such elements, the color and intensity of each element being specified by one half of a byte (called a color command word). Each half byte has the meaning to the Dazzler shown in figure 3.

The command word shown in our example is for "high intensity red." Another important thing to understand about the Dazzler is that it is able to read memory on its own, just like the computer, and at the same time that the computer is running its own program. This is called Direct Memory Access (DMA).

Once the computer tells the Dazzler (through ports 16 and 17) where the picture starts, the Dazzler simply takes over and puts the picture right on the screen. Every 1/30th of a second it reads through the entire 2 K of memory and displays it. This arrangement means that the computer can be changing the picture at the same time it is being displayed.

The way in which the Dazzler reads memory can be seen with the illustration of figure 4.

We see that the picture is divided into four quadrants. As the Dazzler reads across a sequence of locations, beginning with the starting location, it displays the least significant half byte first. It is important to remember this when figuring out exactly where in memory a particular color command word should go.

Let's now go back and see if we can piece this information together to enable us to translate our XY coordinates from the digitizer into a memory location that will cor-

respond to the same place in the Dazzler picture. A logical way to go about this is to load a register pair with the beginning address of the picture, and then add to this address an amount derived from the XY coordinates. We could envision the following sequence of events:

1. Load register pair with picture starting location.
2. Ask: "What quadrant are we in?" That is, "are X or Y or both ≥ 64 ?" If $X \geq 64$, we are in the right half of the screen, and must add 512 to the starting location. If $Y \geq 64$, we are in the bottom and must add 1024 to the starting location. (If both are true we add both.)
3. Subtract 64 from X or Y if they are greater than 64. This way, every point would be translated into the first quadrant, with X and Y values ranging from 0 to 63.
4. Add the final displacement to the register pair as follows:
 - A. Multiply Y by 8; this translates the range from 0-63 to 0-504.
 - B. Mask out last four bits to have this address at far left of quadrant ($X=0$).
 - C. Divide $X(0-63)$ by 4 to get 0-15, remembering the right hand carry bit to determine which half word to write (done by shifting right twice).
 - D. Add this to the address calculated from Y. Now add total result to the previously calculated quadrant address.

Example: $X=47$, $Y=71$. Picture begins at memory location 4096.

1. Load H,L registers with 4096.
2. $X < 64$ while $Y > 64$. So add 1024 to H,L. (We are in lower, left quadrant).
3. Subtract 64 from Y, so translated point is $X=47$, $Y=9$.
4. A. Multiply Y by 8. $9 \times 8 = 72$ (hexadecimal 48).
 - B. Mask out lower 4 bits to get 64 (hexadecimal 48 AND FO gives 40).
 - C. Divide X by 4. $47/4 = 11$. Carry bit = 1.
 - D. Relative location is $64 + 11 = 75$.
Add this to H,L. $5120 + 75 = \underline{5195}$

So, the digitizer is pointing at location 5195 in memory. All this calculation would be done in 8080 machine code, resulting in the hexadecimal address value of 144B.

The 8080 subroutine TRANS (see listing 1 addresses 0067 to 009A) translates the XY coordinates stored in the B and C register

Listing 1, continued:

```

0059 E6 80      ANI    80H      ;MASK ALL BUT MSB
005B 07         RLC          ;PUT MSB IN LSB
005C AA         XRA    D       ;XOR IT WITH ALL HIGHER ORDER BITS
005D 57         MOV    D,A     ;REPLACE RESULT
005E 81         ADD    C       ;PLACE IN LSB OF C
005F 4F         MOV    C,A
0060 1D         DCR    E       ;COUNT DOWN LOOP
0061 7B         MOV    A,E
0062 C2 53 00   JNZ   LOOP
0065 79         MOV    A,C     ;PUT BINARY CODE IN A
0066 C9         RET
0067
;
;ROUTINE WHICH TRANSLATES B,C INTO ADDRESS IN H,L
;E MUST CONTAIN PICTURE STARTING ADDRESS (MOST SIG HALF)
TRANS: MOV    A,B      ;PUT X IN AC
      ANI    40H      ;GET RID OF ALL BUT 64 BIT
      JZ    QUADL     ;IF ZERO (X<64) GO AROUND
      INR   E         ;ADD 2 TO E
      INR   E
      MOV   A,B
      SBI   40H      ;SUB 64 FROM B
      MOV   B,A
      MOV   A,C     ;GET Y COORD
QUADL: ANI    40H      ;GET RID OF ALL BUT BIT 64
      JZ    QUADU     ;IF ZERO (Y<64) GO AROUND
      MOV   A,E
      ADI   04H      ;INCREMENT THIRD BIT OF E
      MOV   E,A
      MOV   A,C     ;SUB 64 FROM C
      SBI   40H
      MOV   C,A
QUADU: MOV   A,B     ;GET X AGAIN
      RRC          ;DIVIDE BY 2
      RAR          ;DIVIDE BY 2 AGAIN
      MOV   B,A     ;STORE IN B
      MVI   A,0     ;CLEAR A
      ADC   A       ;PUT CARRY IN A
      MOV   D,A     ;STORE CARRY IN D
      MOV   A,B     ;GET X/4 AGAIN
      ANI   0FH     ;ZERO HIGHER HALF-WORD
      MOV   B,A     ;SAVE IN B
      MOV   A,C     ;GET Y AGAIN
      RLC          ;MULTIPLY BY 8
      RLC
      RAL
      JNC   LOWER   ;IF NO CARRY, DONT INCREMENT E
      INR   E
LOWER: ANI   0F0H   ;DUMP LOWER HALF-WORD
      ADD   B       ;ADD X DISPLACEMENT
      MOV   L,A     ;LOAD L
      MOV   H,E     ;LOAD H
      RET
;
;ROUTINE TO ERASE 256*A BYTES STARTING AT H,L
ERASE: MVI   D,0   ;CLEAR D,E
      MOV   E,D
      MVI   M,0
NEXT:  INX    H     ;ADVANCE POINTER
      MVI   M,0   ;CLEAR THAT BYTE
      INX    D     ;INCREMENT COUNTER
      CMP   D     ;SEE IF A BYTES WRITTEN
      JNZ   NEXT  ;IF NOT, GO BACK
      RET
END

```

into a Dazzler byte location, and places it in the HL register pair. At the time it is called, register E must contain the most significant half of the starting address of the picture. At the end of the routine, register D is equal to 1 if the most significant half of the byte is to be used, and equal to 0 if the least significant is to be used.

Continued on page 138

The Buried Gold in the SR-52

Clif Penn
911 Northlake
Richardson TX 75080

About the Author

Clif Penn reports on these features as an enthusiastic user of the SR-52. Though he is employed by TI's Central Research Laboratories in Dallas, he wrote the article as an individual user, and much of it is based upon information passed around by the SR-52 users' grapevine in Dallas.

In the April 1976 issue of BYTE, a good overview comparison of the programmable SR-52 and the HP-65 was presented by Bradley Flippin [page 36]. Now some hidden but powerful features of the SR-52 organization will be discussed. At this time these features have not yet appeared in the literature Texas Instruments supplies with the SR-52, but the capabilities are worth documenting for readers who use this calculator.

Register Organization

The SR-52 is arranged internally with 100 programmable registers numbered 00 through 99. The first 20 registers (00 to 19)

Register	Normal Use	Clearing Function
00 - 19	Data Storage	*CMs
20 - 59	Internal and not externally available	—
60 - 69	Operational stack	CLR
70 - 97	Program storage with 8 program steps per register	Affected by program edit
98 - 99	None	None

Table 1: SR-52 Register Organization. The documentation of the SR-52 mentions user programmable data storage in registers 00 to 19. In fact, the internal organization of the machine has a total of 100 registers allocated according to this map. Registers 60 to 69 are the operational stack used in parsing algebraic data entry (see BYTE's February 1976 issue for two articles on the subject). Registers 70 to 97 normally store the calculator's program with 8 program steps per register. Registers 98 and 99 are "free" and can be used for temporary data storage or as a flag. (The registers from 20 to 59 are not available for user programs.)

are those normally used for data storage and called from the keyboard such as RCL 06, STO 19, *EXC 05 and so on. All 20 of these user data registers are cleared simultaneously by pressing *CMs. [All secondary functions are shown with an asterisk (*) convention rather than writing (2nd) (CMs).] Many users have discovered by accident that there are other registers which may be accessed from the keyboard but have an incomplete understanding of how to take advantage of them. Table 1 shows a detailed listing of the registers, their conventional use and how they are cleared.

All of the registers except the internal 20 through 59 can be used in exactly the same way as the conventional 00-19, that is, indirectly addressed, conditionally addressed and so on.

Operational Stack Registers 60-69

If you use a "0" strike over rather than the clear button, registers 60 to 69 become available. Remember, however, that any time a "(" is actually necessary in your program, you use these registers in order from the bottom up. It is rare to use all levels of interestned brackets, so start from 69 and work down if you need extra storage. (When in doubt, do the problem manually and RCL the register of interest and check for 0 contents.)

Program Storage Registers 70-97

The program storage registers 70 through 97 normally store the program at 8 steps per register. These registers are loaded either manually or when you read a preprogrammed magnetic card. In addition they are recorded on the magnetic card in the WRITE mode. This allows you to store data on a magnetic card for later use or updating. The statistics program used as an example incorporates this feature. Any time you delete or insert program steps *after* storing data in the

Reg	Loc	Reg	Loc	Reg	Loc
70	000 - 007	80	080 - 087	90	160 - 167
71	008 - 015	81	088 - 095	91	168 - 175
72	016 - 023	82	096 - 103	92	176 - 183
73	024 - 031	83	104 - 111	93	184 - 191
74	032 - 039	84	112 - 119	94	192 - 199
75	040 - 047	85	120 - 127	95	200 - 207
76	048 - 055	86	128 - 135	96	208 - 215
77	056 - 063	87	136 - 143	97	216 - 223
78	064 - 071	88	144 - 151		
79	072 - 079	89	152 - 159		

program memory, you will alter the register contents. BEWARE! To make life easier, table 2 shows the program locations normally stored in each register.

If you use this feature regularly, here are some memory aids — 8 program steps per register; the first register stores locations starting with 000 (ending with 007 so register 70 may be associated with this); register 80 starts with location 080; register 97 is last.

Bonus Storage Registers 98-99

There are numerous cases when you wish access to the CLR and *CMs feature without losing a constant you may be using regularly. Registers 98-99 are quite useful for this. None of the clearing functions affect them. Power off of course kills everything. You may encounter cases (as on the included programs) where you desire the effect of a flag but are still free to use CLR, *CMs, and reset. Although not nearly as efficient as flag usage, you can simulate a flag condition by

storing any number in register 98 or 99 and use the following sequence:

```

.....
..... *LBL
*EXC *1'
9 *EXC
9
* if zro 9
*1' .
*EXC .
9 .
9 .
. .
. .

```

Just as flag usage, this preserves the data in the display register for further use following the conditional branch instructions. Keep in mind you may need to clear 98 or 99 as an

Table 2: Program Storage Registers and Locations Stored. This table gives the correspondence between program step numbers and register locations 70 to 97. Note that editing operations shift program data throughout this region, so any use of the program storage registers for data should be avoided when editing programs.

A Note About Special Features to Save Program Steps

As a preamble let me emphasize forcefully that short routines should be written with parentheses in normal algebraic form without worrying about the "bells and whistles." This will use more program steps than needed but less time in programming and debugging.

Invariably you will encounter long programs where you need every "twist of the screw" to reduce program steps. The main thing to master is the algebraic hierarchy (pages 46-48 in the *SR-52 Owner's Manual*). Except as altered by parentheses, the order of operations is:

1. Immediate function evaluations (sin, cos, tan, etc).
2. Exponentiation and root extraction (x^2 , y^x , \sqrt{x} , $\sqrt[x]{y}$).
3. Multiplication and division.
4. Addition and subtraction.
5. Perform operations from left to right on each hierarchy level.

For example:

$$(5 \times 7) + (8 \div 2) = 39$$

with or without the parentheses while

$$(5 + 7) \times (8 - 2) = 72$$

but

$$5 + 7 \times 8 - 2 = 59.$$

One equal sign at the end of the equation may replace several right parentheses one might require at the end of an expression.

Another useful feature involves recalling the display register contents by the use of either math functions or memory functions.

$$3 + \sqrt{3} = \text{may be programmed } 3 + \sqrt{x} =$$

$$3 + 1/3 \text{ may be written } 3 + 1/x =$$

$$3 + 3 = \text{cannot be keyed } 3 + =$$

but rather $3 + \text{RCL} = 6.$

Any of the memory functions may be used in this "dummy instruction" manner. On occasion you may wish to store an intermediate result at the very same time as you use the display register contents like this:

$$4 \times 5 + \text{STO } 01 \times 3 = 80,$$

20 stored in register 01.

The "+" sign causes the first multiplication to take place, the STO inserts the display register contents back in the equation and the 01 directs $4 \times 5 = 20$ to be stored in register 01. Had you wanted 5 stored instead, you could have used a dummy memory instruction — — —

$$4 \times 5 \text{ STO } 01 + \text{RCL} \times 3 = 80,$$

5 stored in register 01.

SR-52
User Instructions

TITLE STANDARD DEVIATION (6 BINS) PAGE 1 OF 2

◀A*		▶B*	
D/A	BIN #	MEM	
DEV	LAST %	ENTER	
AVE	-Σ		

STEP	PROCEDURE	ENTER	PRESS	DISPLAY
	OPERATING REGISTERS ARE ALWAYS RO1, RO2, RO3.			
	RO1 STORES THE SUM OF ALL ENTRIES; RO2 STORES THE SUM OF THE SQUARES OF ALL ENTRIES; RO3 STORES THE NUMBER OF DATA ENTRIES.			
	$AVE = \frac{RO1}{RO3} = \frac{\sum X}{n}$			
	$STD DEV = \sqrt{\frac{1}{n-1} [\sum X^2 - \frac{(\sum X)^2}{n}]}$			

TITLE STD. DEVIATION (6 BINS) PAGE 1 OF 2
PROGRAMMER CLIF PENN DATE 5/19/76

SR-52
Coding Form

LOC	CODE	KEY	COMMENTS	LOC	CODE	KEY	COMMENTS	LOC	CODE	KEY	COMMENTS	LABELS
000	112	46	*LBL	03	3	DISP		03	3			A AVE
		15	E	43	RCL	NEW		75	-			B DEV
		42	STO DATA	00	0	n		01	1			C -Σ
		00	0	03	3			95	=			D LAST %
		00	0	81	HLT			30	*YX			E ENTRY
005	117	44	SUM	46	*LBL			42	STO	STO		A
		00	0	11	A	AVE		09	9	DEV		B DEV/AVE
		01	1	43	RCL			09	9			C
		40	*X ²	00	0	ΣX		81	HLT			D BIN #
		44	SUM	01	1	n		46	*LBL			E MEM
010	122	00	0	55	÷			17	*B'	DEV/AVE		REGISTERS
		02	2	43	RCL			43	RCL			00 LAST %
		01	1	00	0			09	9			01 ΣX
		44	SUM	03	3			09	9	DEV		02 ΣX ²
		00	0	95	=			55	÷			03 n
015	127	03	3	42	STO			43	RCL			04 BIN #
		00	0	01	1	AVE		01	1	AVE		05 #
		03	3	81	HLT			09	9			06 2
		81	HLT	46	*LBL			95	=			07 BIN #
020	132	46	*LBL	12	B	DEV		81	HLT			08 #
		13	C	43	RCL			46	*LBL	MEMORY		09 3
		42	STO ROUTINE	00	0	ΣX ²		10	*E'	BIN		10 BIN #
		00	0	02	2			60	if flg	SHIFT		11 #
		00	0	75	-			00	0	RESTORE		12 4
		00	0	REMOVE	75	-		01	1	TO		13 BIN #
025	137	94	+/-	43	RCL			01	1	ORDER		14 #
		44	SUM	00	0	ΣX		03	3			15 5
		00	0	01	1			42	STO	ENTER		16 BIN #
		01	1	AVE	40	*X ²	(ΣX) ²	09	9	NEW		17 #
		40	*X ²	+	55	÷		08	8	BIN		18 6
030	142	94	+/-	43	RCL			90	if zero	#		19
		44	SUM	00	0	n		89	*3'	O=ERROR		FLAGS
		00	0	03	3			75	-	if		0 BIN SORT
		02	2	54)			07	7	greater		1
		01	1	55	÷			95	=	than 7		2
035	147	94	+/-	53	(80	if pos	= ERROR		3
		44	SUM	43	RCL	n						4
		00	0	00	0							TEXAS INSTRUMENTS INCORPORATED

SR-52
User Instructions

TITLE STANDARD DEVIATION (6 BINS) PAGE 2 OF 2

◀A*		▶B*	
D/A	n	BIN #	MEM
DEV	-Σ	LAST %	ENTER
AVE			

STEP	PROCEDURE	ENTER	PRESS	DISPLAY
	BIN CONTROL ROUTINE			
	FIRST PRESS OF *E'			
	(USING BIN #4 AS AN EXAMPLE)			
	BIN #1	BIN #4		
	RO1 ΣX ₁	RO10 ΣX ₄		
	RO2 ΣX ₁ ²	RO11 ΣX ₄ ²		
	RO3 n ₁	RO12 n ₄		
	RESULT			
	DISPLAY = 4			
	RO1 ΣX ₄	RO10 ΣX ₁		
	RO2 ΣX ₄ ²	RO11 ΣX ₁ ²		
	RO3 n ₄	RO12 n ₁		
	NEXT PRESS OF *E'			
	RESTORES ORIGINAL			
	DATA LOCATIONS ASSUMING			
	NO DELIBERATE ACTION HAS			
	RESET FLAG 0 (SUCH AS			
	*Yset OR INV*st flg 0)			

TITLE STD. DEVIATION PAGE 2 OF 2
PROGRAMMER CLIF PENN DATE 5/19/76

SR-52
Coding Form

LOC	CODE	KEY	COMMENTS	LOC	CODE	KEY	COMMENTS	LOC	CODE	KEY	COMMENTS	LABELS
000	112	89	*3'	09	9	Exc's		C'				A
		43	RCL	09	9	ROI		RCL	Find			B
		09	9	LOCATES	36	*IND	RO2	0	n			C
		08	8	NEW	48	*EXC	RO3	3	after			D
		65	X	BIN	00	0	WITH			mem		E
005	117	03	3	ADDRESS	00	0	ROX'			HLT	shift	A
		42	STO	36	*IND	ROY'						B
		00	0	3	42	STO	ROZ'					C n
		00	0		09	9						D
		54)		09	9						E
010	122	42	STO	01	1							REGISTERS
		09	9	3x BIN	94	+/-						00
		09	9		44	SUM						01
		51	SBR		09	9						02
		01	1		09	9						03
015	127	04	4		58	*dsz						04
		08	8		01	1						05
		60	*if flg	"FLIP- FLOP"	055	167	04	4				06
		00	0		08	8						07
		01	1	MEMORY	56	*Ycn						08
020	132	04	4	TO	46	*LBL						09
		00	0	STORE	89	*3'	FLASH					10
		43	RCL	STATUS	85	+	ERROR					11
		09	9		85	+						12
		08	8		81	HLT						13
025	137	50	*st flg		46	*LBL						14
		00	0		19	*D'						15
		81	HLT		43	RCL						16
		01	1		09	9	BIN					17
		22	INV		08	8	#					18
030	142	50	*st flg		81	HLT						19
		00	0		46	*LBL						FLAGS
		42	STO		14	D						0
		09	9		43	RCL						1
		08	8		00	0	LAST					2
035	147	81	HLT		00	0	X					3
		36	*IND	← SBR	81	HLT						4
		43	RCL	LOOP	*LBL							TEXAS INSTRUMENTS INCORPORATED

←
 Figure 1: Standard Deviation Program with 6 Bins. This program allows one to accumulate the statistics for six different sets of data. The "bin control" routine selects which of the six variables is to receive new data. This routine is used to exchange sets of data.

initialization procedure if used in this manner.

Standard Deviation with 6 Bins

This program may be used conventionally without the memory management technique to calculate averages, standard deviations and normalized standard deviations. With the memory management shown, up to six different bins of data may be contained. For example, six different clerks could be compared as to their average orders filled as well as the consistency of their performance. Using the last program card you can store the results and update as often as desired. Likewise you can delete data in an orderly manner to maintain a four week running average and so on.

The user defined keys are used as shown on the program sheet. The bin exchange key—

*E', performs the bin exchange function in a "flip flop" manner. The bin number is

entered from the keyboard, say bin #4. The first time *E' is pressed, registers 01, 02, 03 exchange contents with registers 10, 11, 12 respectively. This places the data of bin 4 in position to be updated by the stored program. The next time you press *E', regardless of what you think you told it, the memory contents are automatically returned to their proper order with a 1 displayed to point out that bin 1 is in the update position. Any time 0 or a number larger than 6 is used as a bin number the display flashes an error.

Each bin consists of three registers which store (1) the sum of all the data entries, (2) the sum of the squares of all the data entries and (3) the number of datum points. The equation used is illustrated on the coding sheet.

Memory to Magnetic Card Program

A program can be written to magnetically record up to 22 memory registers, but this

Figure 2: Memory Management Program. When it is desired to save the data prepared by a program such as the standard deviation program of figure 1, this memory management program is read into the "A" side of the calculator. Its purpose is to copy data from the user data registers (M) to program registers (CARD), and vice versa under control of two keyboard commands. To save data, copy the user registers into the program registers (M → CARD) and write the program on both sides of card; to recover this data, read both "A" and "B" sides of the card, then perform the (CARD → M) transfer. Now load both sides of the standard deviation program to inspect these data.

SR-52
User Instructions

TITLE MEMORY MANAGEMENT (6x3) PAGE 1 OF 1

←A←		←B←	
M→CARD		CARD→M	

STEP	PROCEDURE	ENTER	PRESS	DISPLAY
	TAILORED FOR STANDARD DEVIATION PROGRAM WHICH USES 6 BINS OF 3 REGISTERS EACH. WHEN BINS ARE IN PROPER ORDER, R98=1.			
	AS A SAFETY SIGNAL A BLINKING DISPLAY MUST PRECEDE PRESSING "A". +, =, A IS SUGGESTED. THIS TRANSFERS THE CONTENTS OF REGISTERS 01 THRU 18 TO REGISTERS 80 TO 97 IN ORDER. REGISTERS 80 TO 97 ARE RECORDED ON THE MAGNETIC CARD ALONG WITH THE PROGRAM. IF R98 ≠ 1 NO TRANSFER WILL OCCUR WHEN A IS PRESSED			
	AFTER READING IN BOTH SIDES OF THE CARD, PRESSING "E" TRANSFERS R80 THRU R97 IN ORDER BACK TO R01 THRU R18 WITH A "1" IN THE DISPLAY TO SIGNAL THE REGISTERS ARE AT THEIR HOME POSITIONS.			

SR-52
Coding Form

TITLE MEMORY MGMT (6x3) PAGE 1 OF 1
 PROGRAMMER CLIF PENN DATE 5/19/76

LOC	CODE	KEY	COMMENTS	LOC	CODE	KEY	COMMENTS	LOC	CODE	KEY	COMMENTS	LABELS
000	112	46	*LBL ALL FLGS	18	*C'							A M→CARD
		87	*J' RESET	42	STO	18						B
		81	HLT END	09	9	IN						C
		46	*LBL	09	9	STO PTR						D
		17	*B' SBR	09	9			080	192			E CARD→M
005	117	36	*IND FOR	07	7							A DATA FROM REGISTER 01
		43	RCL BOTH	42	STO	97						B
		09	9 CARD	09	9	IN						C
		08	8 TO	08	8	RCL PTR						D
		36	*IND MEM	17	*B'			085	197			E BIN
		42	STO AND	46	*LBL							REGISTERS
010	122	09	9 MEM	11	A	MEM						00 CONTROL
		09	9 TO	22	INV	TO						01
		01	1 CARD	70	*ferr	CARD						02
		94	+/-	87	*I'	MUST		090	202			03
015	127	44	SUM RCL	24	CE	START						04
		09	9 POINTER	43	RCL	WITH						05
		08	8	09	9	BLINKING						06
		44	SUM STO	08	8	DISPLAY						07
		09	9 POINTER	75	-	# 1		095	207			08
020	132	09	9	01	1	IN R98						09
		58	*dsz	95	=							10
		17	*B'	22	INV			080	172			11
		01	1 MATCHES	90	*ifzto							12
		42	STO STD	87	*I'			100	212			13
025	137	09	9 DEV	18	*C'	18						14
		08	8 BIN #	42	STO	IN						15
		86	*rset	09	9	RCL						16
		46	*LBL	08	8	POINTER						17
		18	*C'	09	9			105	217			18
030	142	01	1 NUMBER	07	7	97						19
		08	8 OF	42	STO	IN						20
		42	STO MEM	09	9	STO						21
		00	0 REGISTERS	09	9	POINTER						22
		00	0 CONTROL REGISTER	17	*B'			110	222			23
035	147	36	*fMn									24
		46	*LBL CARD									25
		15	E TO MEM									26

one records only 18 to match the previous program. Register 98 is used in a compatible manner with the previous program to protect against off loading the updated data in the wrong order, even if the flags have been reset. Several safety precautions are used to protect against losing a long accumulation of data. When the card is dumped into the calculator memory, the card still retains the old data in case of blunders. After the data are updated, if the registers are in their home position, register 98 will contain 1. In the memory to card program this branch condition is used. Up until this point you have lost no data that could not be restored. If you start to transfer memory to card and

find the registers are incorrect, don't panic! Simply reload the standard deviation card, press *E' which replaces the registers where they belong.

To alert you that caution should be used, a blinking error condition display must exist to start the alternate transfer of memory to card with key A. This is readily accomplished in several ways but + = is the one I use. The only keys used are

E — — transfer program storage registers (magnetic card) to data memory
+ = A — — transfer data memory to program storage registers for card writing.■

Continued from page 9

high technology field in which we computer people are all involved, and to the subject of surprising people with new products and industries.

The history of the small computer field to date hardly fits the negative and dismal attitude towards American technological progress cited by the people participating in the session last Monday in the nation's capital. For the present, the USA is where it's all happening in this field: Here you have a large body of people with an education and interest in computers and the middle class wherewithal to exercise that interest; here you have quick reacting entrepreneurs who create a new industrial segment overnight by discovering the people who need computers; here you have a situation where a person can take risks and accept challenges where rewards, while uncertain at the start, can be achieved with diligence, hard work, persistence and a dash of luck. This whole field, created overnight as a response to the pioneering technological innovations of the semiconductor manufacturers, is practically unheard of in the rest of the world. I have personally met several individuals from abroad who are outstanding in their own countries, who have "had their minds blown" by what they've see here on recent trips.

What makes it happen? The pioneering spirit is not dead in this country. While the geographic frontiers are for the present restricted, the technological frontiers have hardly begun to run out. [*Geographical frontiers are now opening up again — there's a whole set of planets, the Moon and Mars, which we now know are just waiting to be colonized by a combination of technology and pioneer risk taking.*] The freedom of the

marketplace and the pioneering response of consumers and entrepreneurs are what I identify as key elements in such leadership. It is an example of diffused responsibility and decision making by individuals, people who perceive a demand and react to it by allocating their own scarce capital and efforts far in advance of the slower and more bureaucratic organizations left over from the previous waves of the same process. Whether involved in small companies or large organizations with proper incentive approaches, these individuals become the focal points of new organizations which grow and achieve a market niche.

For the people in Washington who worry about "America's position" in the world order of commerce, I have a simple conclusion to present: reproduce conditions in a more general context which are similar to those we have seen in personal computing over the last two years. In personal computing we have product definition done by entrepreneurs in response to the actual demands of people; we have a situation where the winning or successful product is measured by the votes of the people purchasing the goods; we have a situation where performance and reputation in the marketplace earn each product a unique position. Increase the competition (and therefore the insecurity) of laggard industries by removing protective regulations and paternalistic subsidies. Minimize the artificial requirements of paperwork done for government agencies and thus maximize the scarce time of the people who are hard at work actually creating a better technological state of affairs. Leave people alone to manage their own business and affairs, and the results will be quite amazing. Let's institutionalize this kind of technological surprise by creating conditions under which it occurs with regularity and civilization progresses as a result.■

DIGITAL DATA RECORDERS USING 3M DATA CARTRIDGES

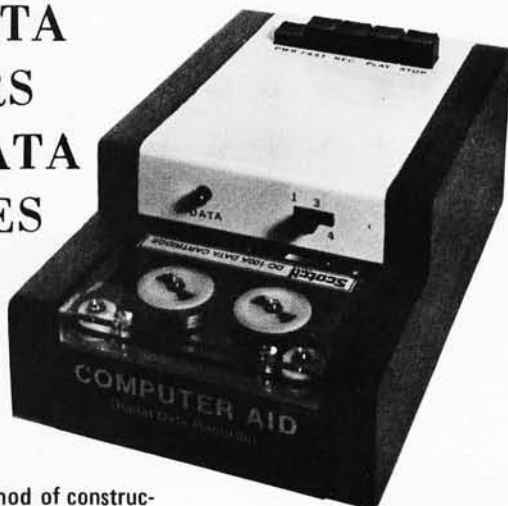

BRAND NEW DESIGN

Featuring the radically new "UNIBOARD" method of construction for data cartridge drives. The major computer manufacturers are changing from cassettes to cartridges at a rapid pace because of freedom from binding and greater data reliability. Now, these professional type units are priced within the range of all data users. Being made primarily as OEM data storage units for the world's major manufacturers, these units, together with controller board and software ROM, are being made available to the individual user as well.

* Appearance and specifications may be changed slightly following acceptance tests now being conducted by OEM users.

Model 3M1
\$169.95

MODEL 3M3 — Uses the 3M Data Cartridge, model DC300. This cartridge contains 300 feet of .250 tape in a sealed container. Records and plays at 9600 baud NRZ, 4800 baud P.E. Nominal speed 8" per second. Max. recommended flux density 1200 fcpi. Using four tracks, you can store nearly 2 megabytes of data on a cartridge. Cartridge measures 4" by 6". Turns counter indicates tape position. Inter-record gap light gives more accurate position. 2SIO(R) is not required for use, but is highly recommended for 8080 and Z80 systems.

COMMON SPECIFICATIONS: FULL SOFTWARE CONTROL of record, play, fast forward and rewind. LED indicates inter-record gaps. EOT and BOT are sensed and automatically shut down recorder. Can also be manually operated using the switches on top which parallel the software control signals when not under software control. Signal feedback makes it possible to software search for inter-record gaps at high speed. 117V — 60 Hz — 5 watts.

TWO I/O PORT CONTROLLER WITH ROM — Controls your terminal and one or two cassettes or cartridge units. On board ROM (For 8080 and Z80) has terminal and cassette software for turn on and go operation. NO MORE BOOTSTRAPPING. Plug in compatible with Altair and IMSAI. Loads and Dumps memory in Hex from the keyboard, formats tape files, punches tape, functions as a word processor and searches for files and four letter strings within files. Keyboard controls the cartridge units above on rewind and fast forward. Special keyboard codes enable you to dump and read Phase Encoded tapes as well as NRZ tapes. (Including K.C. Std.) Call routines give access to these from your software.

MODEL 2SIO(R) — With 1 ROM for NRZ Cassettes \$169.95 (Assembled & Tested) (Half of above Program)

With 2 ROM's for Data Cartridges and P.E. cassettes. \$189.95 (Full Program)

Kits available for \$30 off above prices.

OVERSEAS: EXPORT VERSION — 220 V — 50 Hz. Write Factory or — Datameg, 8011 Putzbrunn, Munchen, Germany; Nippon Automation 5-16-7 Shiba, Minato-Ku, Tokyo; EBASA, Enrique Barges, 17 Barcelona, Spain; Hobby Data, SpireaVagen 5, Malmo, Sweden; G.Ashbee, 172 Ifield Road, London SW 10-9AG.

MODEL 3M1 — Uses the 3M Data Cartridge type DC100A. This cartridge contains 150 feet of .150 tape and is the same cartridge used by H.P. and others. Runs at 4800 baud NRZ, 2400 baud P.E. Tape speed adjustable, but nominally set at 5"/second. Maximum recommended flux density 1200 fcpi. Cartridge measures 2-1/8" by 3-1/4". This model is ultra compact, yet extremely capable. It is intended for word processing, mailing list use and other applications requiring the compact storage of data. Data location is by inter-record gaps and automatic file search. See Common Specs and 2SIO(R) below. 2SIO(R) is not required for use, but is highly recommended for 8080 and Z80 users.

For 8080 and Z80 users: Comes complete with software program listings for the programs on the 2SIO(R) ROM below. 6800 software is being written, but not yet completed. These programs give **FULL SOFTWARE CONTROL**.

CARTRIDGE AVAILABILITY: Cartridges are made by 3M, ITC, Wabash and others. They are available at all computer supply houses and most major computer service centers. We can also supply them at normal current list prices.

NEW: AUDIO CASSETTE INTERFACE* Phase Encoding interface for use with audio cassettes or NRZ recorders. Runs 2400 baud phase encoded on good quality audio cassette recorders. May also be used with 2SIO(R) above to use the 2SIO(R) cassette programs with your audio cassette player. Can also accommodate "Tarbell" tapes and K.C. Std. tapes.

\$50.00, Wired & Tested. — \$35.00, Kit Form.

*NOTE: You do not require an interface with the 3M1 and 3M3 unless you Phase Encode. But, you do need an interface to use the 2SIO(R) with your own audio cassette.

"COMPUTER AID" and "UNIBOARD" are trademarks of the NATIONAL MULTIPLEX CORPORATION. The 3M Data Cartridges are covered by 3M Patents and Marks. "UNIBOARD" Patents Pending.

For U.P.S. delivery, add \$3.00 each item. Overseas and air shipments charges collect. N.J. Residents add 5% Sales Tax. WRITE or CALL for further information. Phone Orders on Master Charge and BankAmericard accepted.

NATIONAL MULTIPLEX CORPORATION
3474 Rand Avenue, South Plainfield, N.J. 07080, Box 288
Phone (201) 561-3600 TWX 710-997-9530

Product Review:



Photo 1: An example of the display output of the Processor Technology VDM-1 driving a standard video monitor purchased locally. Upper and lower case output with optional inverse video lends flexibility to the system. In this photograph, the letters in the inverse video rectangle do not show. A timing distortion in the line with inverse video was found in the author's VDM-1, evidence of which can be seen in this photograph.

Processor Technology VDM-1

Processor Technology's Video Display Module for the Altair, IMSAI, and other Altair compatible machines is of excellent quality. The board has gold plated fingers, and solder resist (green lacquer) on both sides of the board. All component designations are silkscreened and are easily readable. The board displays 16 lines of 64 characters on a standard video monitor or modified TV.

The board has 48 integrated circuits, including 8 91L02As for 1024 bytes of visible

memory, and a character generator ROM. A crystal oscillator generates the required frequencies for a standard video signal. Sockets are provided for all integrated circuits. A DIP switch is provided to set the board options.

The VDM-1 has a hardware cursor feature in its design, controlled by "cursor bytes" within the displayed text. A cursor byte is any byte having the high order bit on. A cursor byte may contain any character, and will be displayed in inverse video. That is, if

D Anderson
755 Southmore Dr W
Ottawa Ontario CANADA

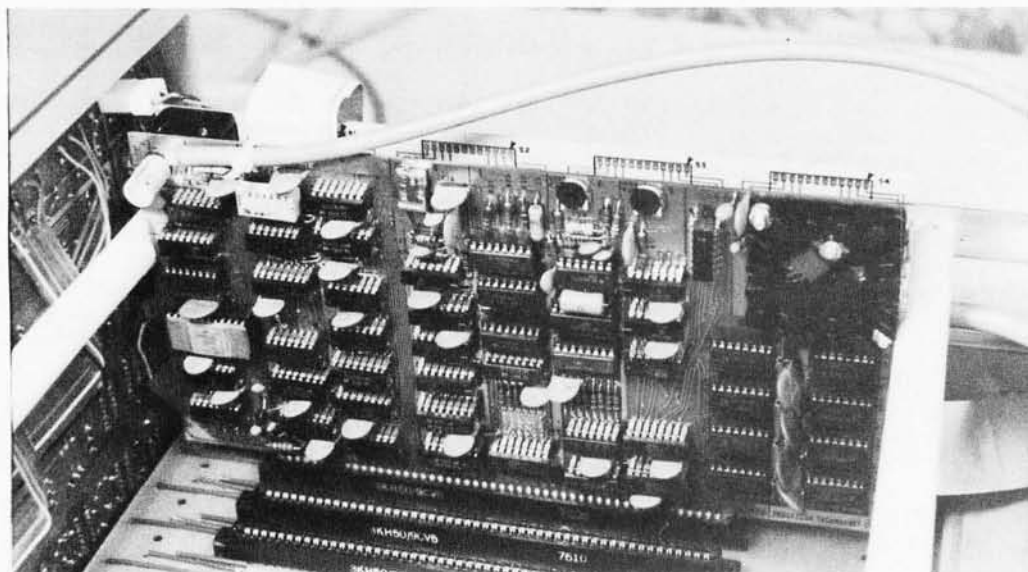

Photo 2: The VDM-1 shown mounted in the author's computer system. The thick coaxial cable at the top of the board runs to the monitor shown in photo 1.

Listing 1: A bootstrap loader, modified from Processor Technology's Teletype bootstrap loader, which allows entry of data in hexadecimal with instant display on the video output of the VDM-1. The author's ASCII keyboard is interfaced through 8080 ports 10 and 11 (hexadecimal). The VDM-1 control register is interfaced to port 8C. The VDM-1 memory in the author's system is located at hexadecimal addresses 8800 to 8BFE.

1
 8080 MACRO ASSEMBLER, VER 2.3 ROOT LOADER ERRORS = 0 PAGE 1

```

      TITLE 'ROOT LOADER'
0000      ORG 0
000F      CURSR EQU 5FH
000C      VDM EQU 8800H
0004      VDMND EQU 8CH ; 8800H + 400H
0008      STACK EQU 4000H
0009      VT EQU 11
000D      CR EQU 13
      ;
      ;
      ENTRY ROOT,DSPLY
      ;
0000      R00T: LXI SP,STACK
0003      CALL INIT ; INITIALIZE KB & VDM
0006      LXI D,VDM ; CLEAR SCREEN
0009      MVI A,VT ; VERTICAL TAB CLEARS THE SCREEN
000B      STAX D
000C      LXI R,0070H ; SET LOAD ADDR
      ;
000F      ASHEX: MVI L,0 ; CLEAN HOUSE
0011      LOOP1: CALL INB ; GET A BYTE
0014      CALL DSPLY ; DISPLAY IT
      ;
0017      DE30 SRI 00 ;
0019      F-A2C0M JM (ONEW) ; CONVERT TO BCD
001C      FE0A CPI 10
001E      DA230M JC DOIT
0021      C6F9 ADI 0F0H ; CONVERT A-F DOWN
0023      29 DAD H
0024      29 DAD H
0025      29 DAD H
0026      29 DAD H
0027      85 ADD L
0028      0F MOV L,A
0029      C3110M JMP LOOP1
      ;
002C      FEF0 ONEW: CPI 0F0H ; IS IT SPACE?
002E      C20F0M JNZ ASHEX
0031      7D MOV A,L ; GET CHR FROM L
0032      02 STAX R ; STORE BYTE
0033      03 INX R ; POINT TO NEXT BYTE
0034      C30F0M JMP ASHEX
      ;
0037      AF INIT: XRA A ; SET CTL BITS FOR PIO DWR
0038      D310 OUT 10H
003A      D311 OUT 11H ; INDICATE ALL LINES INPUT
003C      D38C OUT 8CH ; SET VDM CTL
003E      3E06 MVI A,06H ; TURN ON DATA RES
0040      D310 OUT 10H
0042      C9 RET
      ;
0043      DB10 INB: IN 10H ; GET STATUS

```

1
 8080 MACRO ASSEMBLER, VER 2.3 ROOT LOADER ERRORS = 0 PAGE 2

```

0045      E680 ANI 80H ; DATA AVAILABLE?
0047      CA430M JZ INB
004A      DB11 IN 11H ; GET CHAR IN A
004C      E67F ANI 7FH ; DROW PARITY BIT
004E      C9 RET
      ;
004F      12 DSPLY: STAX D ; DISPLAY IT
0050      13 INX D
0051      ER DSCRS: XCHG
0052      365F MVI M,CURSR ; SET UP CURSOR
0054      23 INX H
0055      3608 MVI M,VT ; SET UP VERTICAL TAB TO CLEAR SCREEN
0057      2B DCX H
0058      ER XCHG
0059      F5 PUSH PSW ; SAVE CHAR
005A      7A MOV A,D ; CHECK FOR END OF SCREEN
005B      FEBC CPI VDMND ; END OF VDM MEMORY?
005D      C2670M JNZ S+10
0060      110088 LXI D,VDM ; RESET TO START
0063      F1 POP PSW ; RESTORE CHAR
0064      C3510M JMP DSCRS
0067      F1 POP PSW ; RESTORE CHAR
0068      C9 RET
      ;
      END

```

NO PROGRAM ERRORS

1
 8080 MACRO ASSEMBLER, VER 2.3 ROOT LOADER ERRORS = 0 PAGE 3

SYMBOL TABLE

```

* 01
A      0007      ASHEX 000F      R      0000      R00T 0000 *
C      0001      CR      000D *
DOIT   0023      DSCRS 0051      DSPLY 004F      E      0003
H      0004      INB   0043      INIT  0037      L      0005
LOOP1  0011      M     0006      ONEW  002C      PSW  0006
SP     0006      STACK 0400      VDM   8800      VDMND 008C
VT     000B

```

the display is normally white characters on a black background, a cursor byte will be displayed as a black character on a white background. By setting one position on the DIP options switch, all cursor bytes, if any, will blink at about a one second rate.

Other positions on the DIP options switch cause control characters, such as STX, DEL, etc, to be blanked. If not blanked, they appear as strange characters. Another switch controls the two special blanking characters: carriage return and vertical tab. If the switch is on, a carriage return character will automatically blank itself and all data following it on the line. The vertical tab character will blank itself and all data following it in the memory buffer. In both cases, only the data on the screen is blanked; the data in memory is left unaltered. If unused portions of display memory are to be used as a program segment, this prevents "garbage" from appearing on the screen.

The 1 K static programmable memory buffer is directly addressable as memory in the Altair. Displaying data on the screen involves nothing more than storing data into the VDM's memory. Sounds easy, and it is. The display is essentially instantaneous. The sample dump program shown in listing 1 is impressive in that memory is dumped instantly.

The VDM board contains two 4 bit registers which control the scrolling and window shading of the display. "What is window shading?" you ask. Window shading is the process of blanking a display from the top down to a specified line. This is performed automatically by simply loading the window shade register. Scrolling is also easy and performed the same way. Both registers are loaded simultaneously by issuing an output instruction to the board.

This all sounds pretty simple, but it turns out that a fair amount of software is required to simulate the operation of a dumb CRT. This is because a carriage return and line feed sequence requires that you set your memory pointer back to the beginning of the line, add 64 to it, and check that you

Listing 2: A hexadecimal memory dump program which displays 256 bytes of memory formatted 16 bytes per line, 16 lines in all. This program displays one page starting at the location stored in address 0074 (hexadecimal) and then waits for a keyboard input before proceeding to display the next page.

0000 MACH0 ASSEMBLER, VER 2.3 DUMP MEMORY ON SCREEN ERRORS = 0 PAGE 1

```

TITLE DUMP MEMORY ON SCREEN
:
: THIS PROGRAM DISPLAYS MEMORY ON THE SCREEN, ONE PAGE
: AT A TIME. 16 BYTES ARE DISPLAYED IN HEX ON EACH LINE.
: 16 LINES ARE DISPLAYED AT ONCE. EACH LINE BEGINS
: WITH THE HEX ADDRESS. AFTER EACH PAGE IS DISPLAYED, THE
: PROGRAM HALTS INDEFINITELY, UNTIL ANY CHARACTER
: IS TYPED; THEN THE NEXT PAGE IS DISPLAYED.
:
0070      ORG      0074H
0070      VDM     EQU 8000H
0071      STACK  EQU 4000H
0072      INH     EQU 0043H
0073      CH      EQU 13
:
: ENTRY DUMP,BLANK,FINH,CRLF,CLEAR
:
0074      LXI     SP,STACK
0075      LXI     H,M      ; ADDR OF MEMORY TO BE DISPLAYED
0076      DUMP:  CALL  CDFAR  ; CLEAR VDM MEMORY
0077      LXI     D,VDM*6  ; POINT TO VDM MEMORY + 6 OFFSET
0078      MVI     R,16    ; 16 LINES
0079      DMLP1:  MOV     A,H      ; DISPLAY ADDR
0080      CALL    RINH
0081      MOV     A,L
0082      CALL    RINH
0083      CALL    BLANK  ; FOLLOWED BY A BLANK
0084      CALL    CDFAR
:
0089      MVI     C,16    ; 16 BYTES PER LINE
008A      DMLP2:  MOV     A,M      ; GET BYTE TO CONVERT TO HEX
008B      CALL    RINH    ; CONVERT TO ASCII HEX
008C      CALL    BLANK   ; DISPLAY A BLANK
008D      INX     H        ; POINT TO NEXT BYTE TO BE DISPLAYED
008E      JCR    C
008F      JNZ    DMLP2   ; DO ALL 16 BYTES
:
0097      CALL    CRLF    ; POINT TO NEXT LINE ON SCREEN
0098      DCR    R
0099      JNZ    DMLP1   ; DO ALL 16 LINES
009A      CALL    INH    ; WAIT FOR INPUT
009B      JMP     DUMP+3 ; DO NEXT PAGE
:
: CONVERT ACCUM TO ASCII HEX WHERE D,E POINT
:
00A4      PUSH  PSW      ; SAVE BYTE TO BE CONVERTED
00A5      RAR          ; SHIFT RIGHT 4 BITS
00A6      RAR
00A7      RAR
00A8      RAR
00A9      CALL   RINI   ; CONVERT TO ASCII
00AA      STAX  D        ; DISPLAY ASCII BYTE

```

0000 MACH0 ASSEMBLER, VER 2.3 DUMP MEMORY ON SCREEN ERRORS = 0 PAGE 2

```

00AD      INX     D        ; POINT TO NEXT POSN ON SCREEN
00AE      POP    PSW      ; GET ORIGINAL BYTE
00AF      CALL   RINI   ; CONVERT TO ASCII
00B0      STAX  D        ; DISPLAY IT
00B1      INX     D        ; POINT TO NEXT POSN ON SCREEN
00B2      RET
:
: CONVERT A BYTE TO ASCII HEX
:
00B5      ANI    0FH      ; LOW 4 BITS
00B6      ADI    4H       ; MODIFY FOR ASCII
00B7      CPI    5B       ; DIGIT 0-9?
00B8      RC
00B9      ADI    7        ; MODIFY FOR A-F
00BA      RET
:
: DISPLAY A BLANK
:
00BF      MOV    A,' '    ; GET A BLANK
00C0      STAX  D        ; DISPLAY IT
00C1      INX     D        ; POINT TO NEXT POSN ON SCREEN
00C2      RET
:
: ISSUE CARRIAGE RETURN LINE FEED FOR VDM
:
00C4      MOV    A,E      ; POINT TO NEXT LINE ON SCREEN
00C5      ANI    0C0H    ; LENGTH OF LINE + 6 OFFSET
00C6      ADI    70
00C7      MOV    E,A
00C8      MVI    A,0
00C9      ADC    D
00CA      MOV    D,A
00CB      RET
:
: BLANK VDM MEMORY
:
00CF      LXI    D,VDM    ; POINT TO VDM BUFFER
00D0      MVI    A,' '    ; GET A BLANK
00D1      MVI    R,16    ; 16 LINES
00D2      DMLP3:  MVI    C,64 ; OF 64 BYTES
00D3      DMLP4:  STAX  D    ; BLANK 1 BYTE
00D4      INX     D        ; POINT TO NEXT BYTE IN BUFFER
00D5      DCR    C
00D6      JNZ    DMLP4   ; DO ALL 64 BYTES
00D7      DCR    R

```

haven't exceeded the limit of the memory buffer. You then must store your cursor byte, and add 1 to your scrolling counter, and verify that it has not passed 16. All of this adds up in memory requirements and programming time. It might have been better to have an automatic carriage return, line feed sequence handled directly by the hardware.

Another unusual feature of the board is that it has a circuit that creates a pulse approximately four times per second. You can tie this to the interrupt line or vectored interrupt bus if you wish to try some real time programming. Or you can test this timing pulse by issuing an input command to the board: Data bit 0 will go high every

VDM-1 SUMMARY

- | | |
|--------------------------------------|--|
| Product: | Altair-compatible video display board. |
| Manufacturer: | Processor Technology. |
| Price: | \$199 kit. |
| Power | +8 V/1 A max; +16 V/50 mA |
| Consumption: | typical; -16 V/30 mA typical. |
| Size: | 5.3 x 10.0 inches (13.5 x 25.4 cm) (Altair/IMSAI card cage dimensions). |
| Display Size: | 16 lines of 64 characters. |
| Storage Medium: | 91L02A low power static RAMs. |
| Features: | <ul style="list-style-type: none"> • upper and lower case displayed, as well as many special characters. • instant updating of display. • lacquer protected board (both sides). • quarter-second timer on board. • scrolling and window-shading software controlled. • automatic blanking with CR and VT. • control characters may be blanked. • multiple (optionally blinking) cursors. |
| Auxiliary Equipment Required: | Television Monitor. Interconnection Cables for Monitor. To be used with an Altair compatible mainframe. |
| Board Quality: | Excellent. |
| Documentation: | Excellent. |
| Delivery: | Slow, 60 days minimum. |
| Comments: | <ol style="list-style-type: none"> 1. More software required than dumb CRT or TTY. 2. Instant update of display. 3. Monitor may not be able to display very many inverse video bytes. |

quarter second. Thus if you were scrolling through a large source program, you could use this to delay the display on each line in multiples of a quarter second, without writing any complicated timing loops.

The documentation provided with the board is excellent and includes sample photos of what should be displayed at various points in the assembly process. An oscilloscope should not be required, but will obviously be helpful if you happen to get a bad chip.

Incidentally, one of several possible character generator ROMs will be provided, depending on availability. You have no choice.

One thing that should be pointed out is that your video monitor may not be able to display very many inverse video characters, as the horizontal sync gets messed up.

Although the board contains its own on-board horizontal and vertical video controls, it may not be possible to correct the image. As an example, see photo 1. The white rectangle on the left of the screen contains the words "inverse video" (they don't show up very well in the photo). Note the resulting slant to the rest of the characters on that line and on the next. I was unable to adjust the set or the board to

Listing 2, continued:

```

00DF C2D600 JNZ DMLP3      I D0 ALL 16 LINES
00E2 3E00 MVI A,0
00E4 D38C OUT BCH      I INITIALIZE VDM
00E6 C9 RET

I
0000 MACH0 ASSEMBLER, VER 2.3 DUMP MEMORY ON SCREEN ERRORS = 0 PAGE 3

                                END
NO PROGRAM ERRORS
I
0000 MACH0 ASSEMBLER, VER 2.3 DUMP MEMORY ON SCREEN ERRORS = 0 PAGE 4

                                SYMBOL TABLE

* 01
A 0007 R 0000 RINI 0005 BINH 00A4
BLANK 00BF C 0001 CLEAR 00CF CR 000D *
CRLF 00C4 D 0002 DMLP1 007E DMLP2 0088
DMLP3 00D6 DMLP4 00DB DMPG0 007C * DUMP 0076
E 0003 H 0004 INB 0043 L 0005
M 0006 PSW 0006 SP 0006 STACK 0400
VDM 8800

H:
.

```

eliminate the problem. In summary, the ProTech VDM board is well worth the money. Expect a minimum of 60 days' delivery, but don't hold your breath. Demand for this product is brisk. Incidentally, video monitors can be purchased from audio visual supply dealers for \$150 or so. An appropriate connector from the board's cable to the set can be obtained at Radio Shack. ■





wire wrapping center

your one stop shopping for quality electronic parts and tools.



50ft. wire roll



dip socket



Hobby-wrap tool



pre-stripped wire

OK MACHINE & TOOL CORPORATION

3455 Conner St., Bronx, N.Y. 10475 / (212) 994-6600 / Telex 125091

The POLY 88 Microcomputer System

The POLY 88 is not for everybody; but if you are into computers, or considering getting a system, the POLY 88 is a machine to think about.

For the hardware buff:

- Popular 8080 central processor
- Single-board CPU with vectored interrupt, real time clock, single step logic, and serial I/O
- Video interface card to handle communications — generates video to TV monitor and provides parallel keyboard input port
- Serial and cassette interfaces on small mini-cards that plug directly into CPU board with ribbon cables
- 300 baud cassette
- ROM monitor with powerful debugger, video software, and bootstrap loader
- Backplane and power supply on one board simplifies construction
- Rugged 6 amp power supply
- All circuit boards are high quality double sided with plated through holes
- System is compatible with a wide range of Altair peripherals on the market
- Minimum point to point wiring means that the POLY 88 kit can go together in three evenings!

Front Panel Display:

Routines in the 1024 byte monitor display the contents of each of the 8080 internal registers, and the value in memory that is addressed by each register pair. Programs may be executed one instruction at a time. Data at any location in memory can be displayed and may be easily altered. All front panel data is entered in hexadecimal notation for operator convenience.

For the software buff:

Software is what the POLY 88 was designed for. The user can go all the way from using higher level languages like BASIC to developing machine code with the aid of our assembler. Our BASIC is a full 8K BASIC with character and byte manipulation capabilities; and it is designed to run on our system. No kludging up or special fixes needed to run on multiple I/O devices. Best of all, the programmer is finally free of the teletype emulation mode so the video display can be used to full advantage. The video display provides a unique opportunity to write new types of programs and games. Characters (16 lines of 64) and graphics (48 by 128 grid) are part of the processor's memory, so the display may be altered extremely fast — less than 20 milliseconds to write the entire screen. The 1024 byte ROM monitor provides many I/O handling routines, leaving the programmer free to concentrate on his particular application. The POLY 88 hardware provides many of the additional features that programmers have come to expect from computer systems, such as vectored interrupt (which allows multiple concurrent I/O handling) and real time clock. These features are standard equipment and are included in every POLY 88. So, whether you want to develop a new computer language or fight Klingons, the POLY 88 hardware provides a firm foundation on which to realize your programming fantasies.

For the person new to computers:

For those of you who are just getting started with computers the POLY 88 is a machine that was designed to be easy to use. No complicated hardware setup and software fixes needed. No one should have to learn all the inner workings of a computer just to enjoy one at a reasonable price. With the POLY 88, you can "play" pre-developed programs and then explore writing programs in either BASIC or assembly language, as your interests expand.

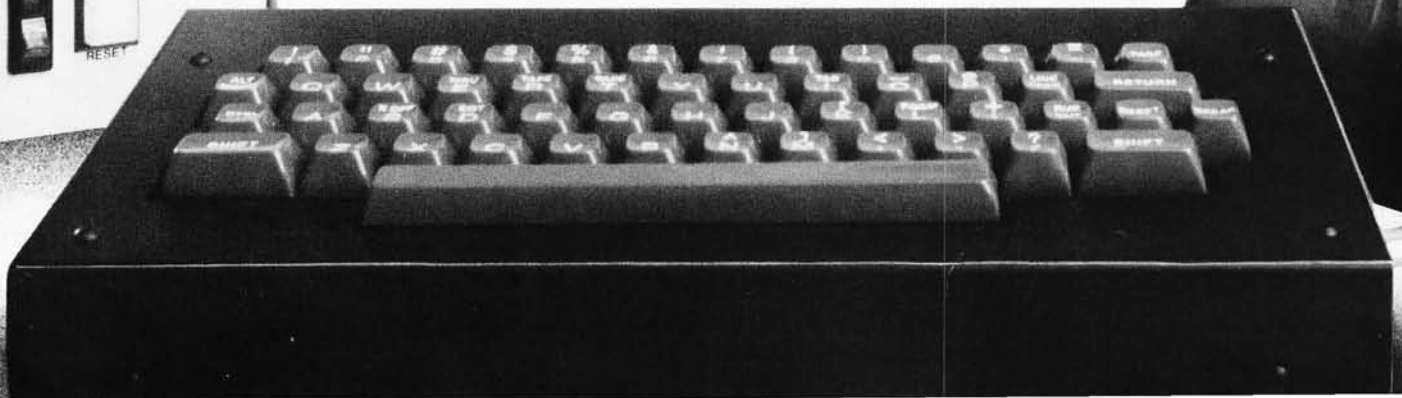

```

PC 005A 08 0C 7E B7 C2 59 00 35
SP 0FFA FF 5A 00 FF 03 4C 0C 58
HL 0C08 23 00 00 FF 7F 00 00 18
DE 0C51 76 00 C9 3F 2F 2E 3F 2F
BC 0000 FF FF FF 31 00 10 06 FF
AF FF86
      ↑

FFF8 FF FF FF FF FF FF FF
0000 31 00 10 06 FF C3 3F 01
0008 F5 C5 05 E5 2A 38 0C E3
0010 F5 C5 05 E5 2A 3A 0C E3
0018 → F5 C5 05 E5 2A 3C 0C E3
0020 F5 C5 05 E5 2A 3E 0C E3
0028 F5 C5 05 E5 2A 40 0C E3
0030 E5 C3 40 00 F1 E1 F3 C9

```

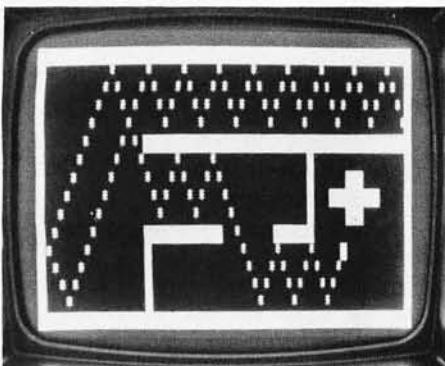
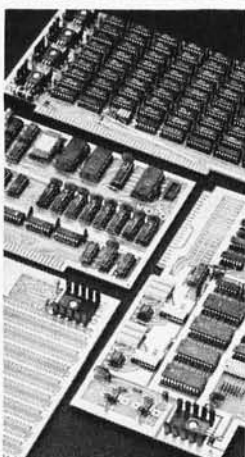

POLY 88 System Prices

System 1 kit includes 8080 vectoral interrupt processor board with real time clock, 1/2K of RAM, and 1K monitor on ROM; Video Terminal Interface for displaying 16 lines of 32 characters on video screen and inputing keyboard signals; cabinet, backplane, and power supply; complete assembly, theory, and operation manual. \$595.

System 2 kit includes all items in System 1 and a Byte/biphase cassette interface kit. \$690.

System 3 kit includes System 2 plus 8K of RAM with BASIC and assembler programs on cassette tape. \$990.

System 4 is the complete kit. It includes System 3 with TV monitor, keyboard, and cassette recorder with all necessary cables and connectors. \$1350.

System 7 is System 4 assembled, tested, and ready to run. \$1750.

Accessories:

8K RAM kit. \$300. Assembled \$385.

POLY I/O Ideaboard, hardware prototyping kit board. \$55.

Analog Interface (1 channel) kit. \$145.

All prices and specifications subject to change without notice. Prices are U.S.A. only. Calif. residents add 6% sales tax. Prepaid orders shipped postpaid. Bankamericard and Master Charge accepted.

If you haven't seen the POLY 88 yet, why don't you wander down to your local dealer and see what personal computing can be like.

WEST

- Bits N Bytes, 679D S. State College Blvd., Fullerton, CA 92631 (714) 879-8386
- Byte Shop Arizona, 3237 S. Fairfield Dr., Tempe, AZ 85282 (602) 894-1129
- Byte Shop Campbell, 2559 S. Bascom, Campbell, CA 95008 (408) 377-4685
- Byte Shop Mountain View, 1063 W. El Camino Real, Mountain View, CA 94040 (415) 969-5464
- Byte Shop Palo Alto, 2227 El Camino Real, Palo Alto, CA 94306 (415) 327-8080
- Byte Shop Pasadena, 496 S. Lake Ave., Pasadena, CA 91101 (213) 684-3311
- Byte Shop Portland, 2033 SW Fourth Ave., Portland, OR 97201 (503) 223-3496
- Byte Shop San Fernando Valley, 18424 Ventura Blvd., Tarzana, CA 91356 (213) 343-3919
- Byte Shop Walnut Creek, 2989 N. Main St., Walnut Creek, CA 94596 (415) 933-6252
- Byte Shop Westminster, 14300 Beach Blvd., Westminster, CA 92683 (714) 894-9131
- The Computer Center, 8205 Ronson Rd., San Diego, CA 92111 (714) 292-5302
- Computer Components, Inc., 5848 Sepulveda Blvd., Van Nuys, CA 91411 (213) 786-7411
- The Computer Mart, 625 W. Katella # 10, Orange, CA 92667 (714) 633-1222
- Computer Systems Unlimited, 18886 Hesperian Blvd., Hayward, CA 94541, Hrs. W-F, by appt., S&S 1-7 (415) 278-2667

MIDWEST

- Computer Workshop of Kansas City, 6903 Blair Rd., Kansas City, MO 64152 (816) 741-5050
- The Computer Room, 1455 S. 1100 East Salt Lake City, UT 84105 (801) 466-7911
- The Data Domain, 111 S. College, Bloomington, IN 47401 (812) 334-3607
- The Data Domain, 7027 N. Michigan Rd., Indianapolis, IN 46224 (317) 251-3139
- itty bitty machine company, 1316 Chicago Ave., Evanston, IL 60201 (312) 328-6800
- The Micro Store, 634 S. Central Expwy., Richardson, TX 75080 (214) 231-1096

EAST

- Micro Computer Systems, Inc., 144 S. Dale Mabry Hwy., Tampa, FL 33609 (813) 879-4301/4225
- Elecon Corp., "The Computer Store", 4921-72 Ave. No., Pinellas Park, FL 33565 (813) 541-3021
- Computer Shop 11111111, Route 16B, Union, NH 03887 (603) 473-2323
- Computer Workshop, 5709 Frederick Ave., Rockville, MD 20852 (301) 468-0455
- Hoboken Computer Works, No. 20 Hudson Pl., Hoboken, NJ 07030 (201) 420-1644
- The Computer Mart of New Jersey, Inc., 151 Kline Blvd., Colonia, NJ 07067 (201) 574-2173



PolyMorphic Systems

737 S. Kellogg, Goleta, CA 93017
(805) 967-2351

Stretch That 6800 Clock

Jerry Henshaw
 Aptec Inc
 POB 15296
 Tulsa OK 74115

I recently completed construction of my Southwest Technical Products M6800 Computer System. One of my first projects was to build a slow memory interface to allow the M6800 microprocessor to communicate with memory devices that have slow access times. The SWTPC system runs at 895 kHz. This clock rate forces any memory element to have an access time of approximately 700 ns or less. The M6800 running at full speed (1 MHz) requires memory devices to have an access time of 575 ns or less. I wanted to use electrically erasable read only memories to store an audio cassette operating system. These EROMS have access times in the one microsecond range and are therefore too slow for a M6800 system running at maximum speed or at the SWTPC 6800 clock rate.

There are two approaches to the slow memory problem. One could slow the system clock down to a point where it is compatible with the slowest memory element in the system. This approach is undesirable since you force the entire system to slow down because of a few slow memory devices. I will admit that slowing down the system clock is indeed the easiest to implement. The other approach would be to slow down the clock only when the processor is communicating with a slow memory element. This scheme would allow the processor to run at full speed when not communicating with slow memory devices. Thus, the processor is slowed down only when necessary. This is the approach that I have chosen.

Before we can design a slow memory interface, it is important to understand the operation of the M6800 during a read and a write cycle to memory. The M6800 uses a two phase, non-overlapping clock for timing purposes. All data transfers are synchronized with the Phase 1 ($\Phi 1$) or Phase 2 ($\Phi 2$) clocks.

Figure 1a shows a read data from memory cycle of the M6800. The cycle starts with $\Phi 1$ going high. Approximately 300 ns

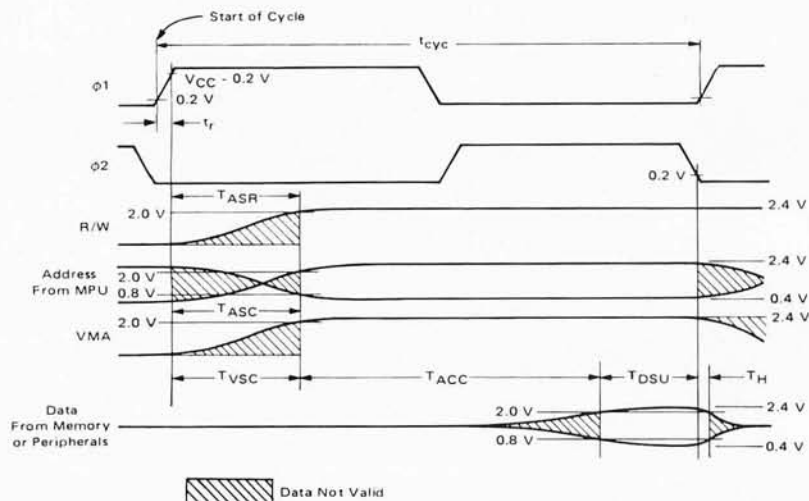

Figure 1a: Nominal Memory or Peripheral Read Cycle for the Motorola 6800 Processor. This figure illustrates the timing relationships between the various signals of the processor. Note the requirement that data be present within T_{ACC} which is 575 ns for a full speed 1 MHz clock, or about 650 ns in the Southwest Technical Products system with its 895 kHz clock. This diagram is reproduced courtesy of Motorola Semiconductor Products Inc, from page 4-51 of the M6800 Microprocessor Applications Manual.

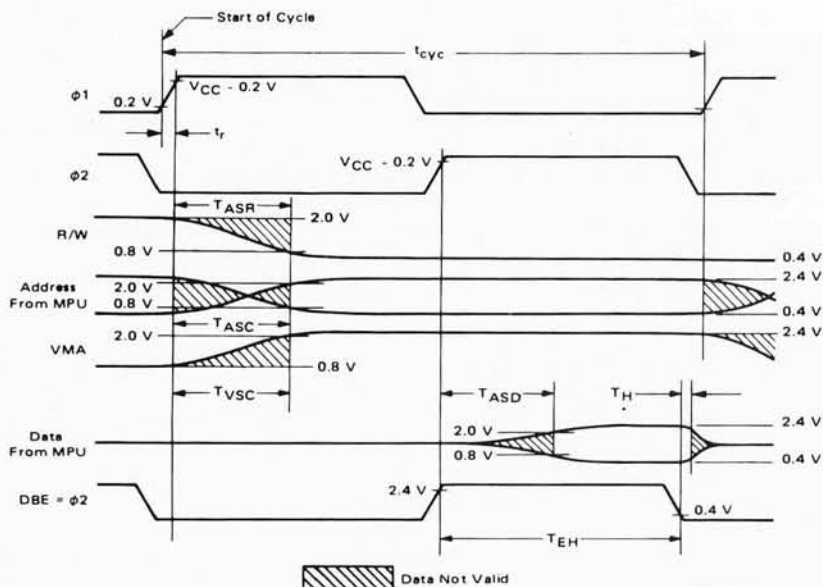

Figure 1b: Nominal Memory or Peripheral Write Cycle of the Motorola 6800 Processor. This figure illustrates requirements for the process of writing data into a memory or peripheral location in address space. The diagram is reproduced courtesy of Motorola Semiconductor Products Inc, from page 4-51 of the M6800 Microprocessor Applications Manual.

later the processor raises the read write line, RW, then places a memory address on the bus, and then activates the valid memory address line, VMA. All of this occurs during the Φ_1 portion of the cycle. Φ_1 is active for approximately 500 ns for a system running at 1 MHz. Φ_2 becomes active after the fall of Φ_1 . It is during the Φ_2 portion of the cycle that data is retrieved from memory. The data from the memory device must be stable at least 100 ns before the fall of Φ_2 . The access time of the M6800 is measured from the rise of VMA line to the presentation of data from the memory element. If the

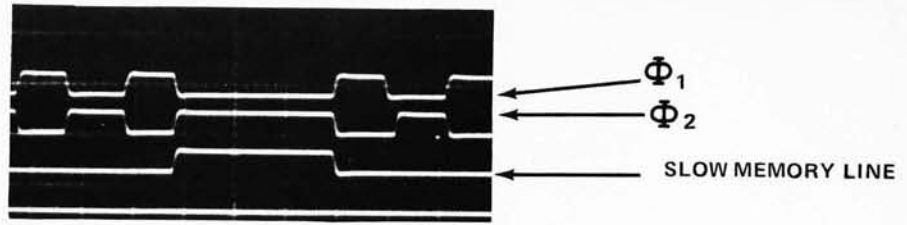

Photo 1: This is an oscilloscope camera tracing of the slow memory interface timing resulting from the author's circuit. The upper traces are Φ_1 and Φ_2 (see markings). The lower trace shows the slow memory line, which stretches the Φ_2 out for one full clock cycle of extra time.

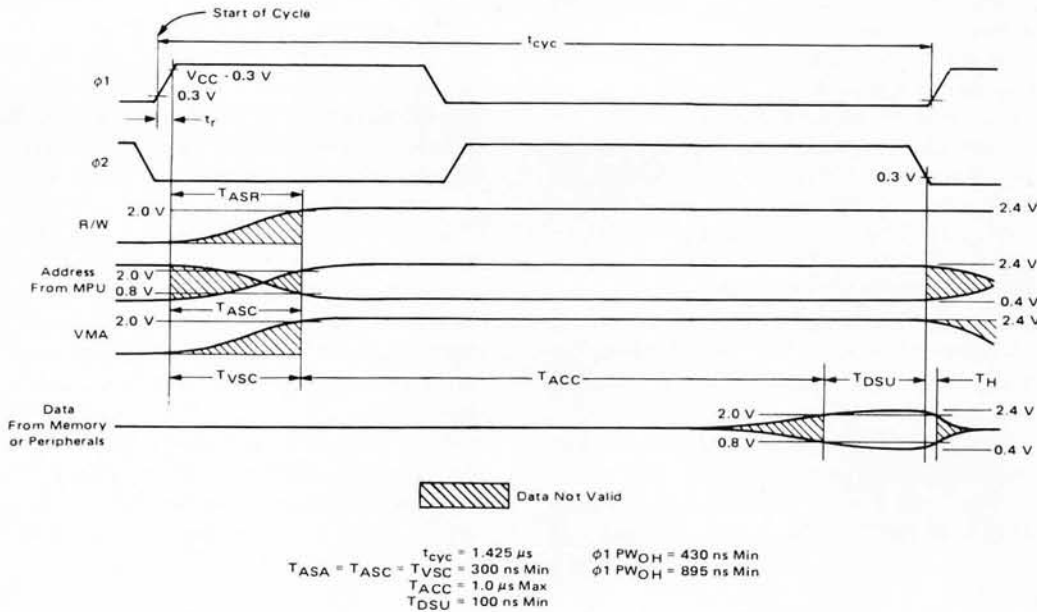

Figure 2a: Nominal Memory or Peripheral Read Cycle, stretched by holding the Φ_2 state to accommodate slow memory circuits. This diagram is reproduced courtesy of Motorola Semiconductor Products Inc, from page 4-52 of the M6800 Microprocessor Applications Manual. In the SWTPC system modification described, the actual timing values are scaled to its clock speed, but the idea is the same.

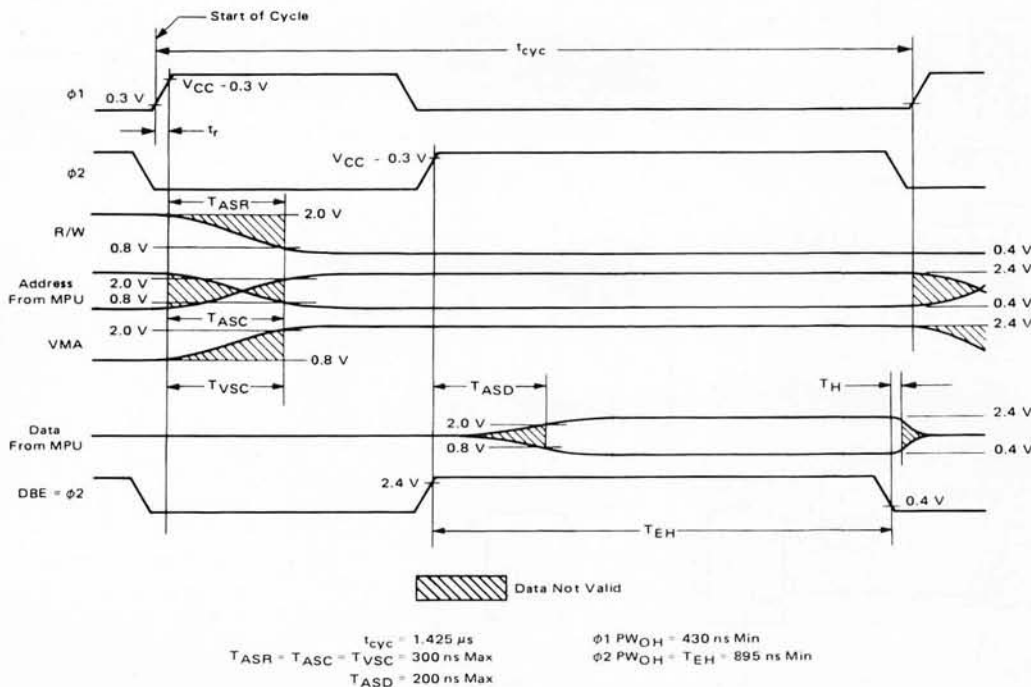

Figure 2b: Nominal Memory or Peripheral Write Cycle, stretched by holding the Φ_2 state to accommodate a slow memory circuit. This diagram is reproduced courtesy of Motorola Semiconductor Products Inc, from page 4-53 of the M6800 Microprocessor Applications Manual.

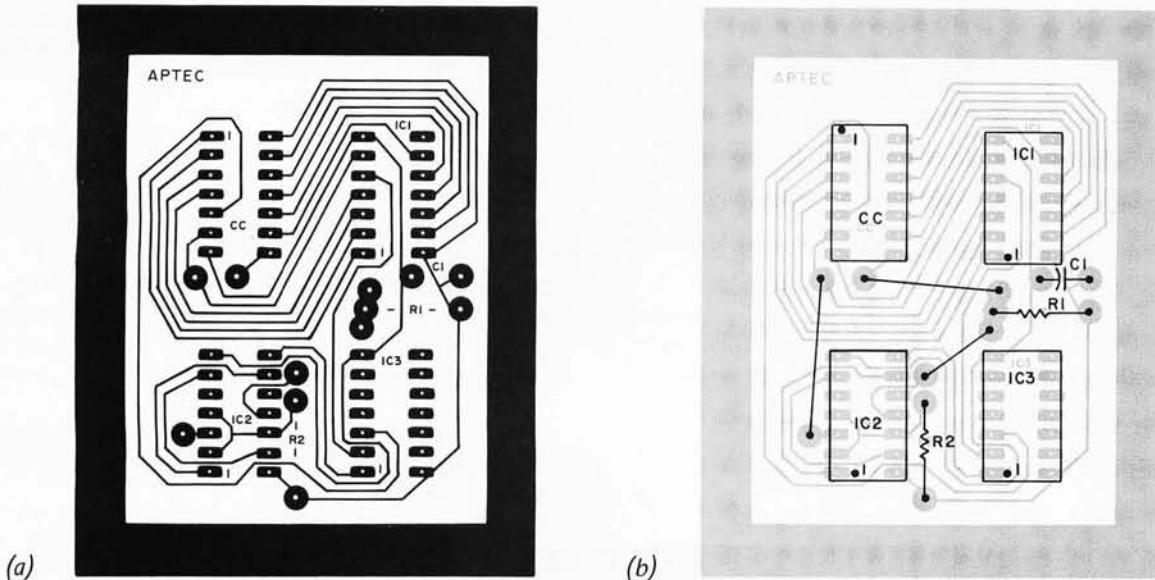

Figure 4: This is the one to one artwork of the slow memory interface printed circuit board. The components are mounted on the reverse side of this pattern (as if they were on the other side of this magazine page). Locations of the integrated circuits are marked IC1, IC2 and IC3 with pin 1 indicated in each case. The component carrier position is marked CC. The resistors and capacitor locations are indicated in the etch pattern. The overlay at right shows locations of the three jumpers and discretes required to complete the circuit. This board is available from Aptec Inc, POB 15296, Tulsa OK 74115, at a price of \$2 postpaid, completely etched and drilled. A complete kit of parts is also available for \$6.25 from the same source.

mounted on a printed circuit board. Figure 4a shows the artwork for the slow memory interface printed circuit board and figure 4b shows the parts placement on this printed circuit board. The component carrier provides the interconnect to the SWTPC MPU board. The interface board is plugged into IC slot 20 on the SWTPC MPU board via the component carrier. IC1 of the slow memory interface is equivalent to IC20 on the SWTPC MPU board. It is a 7474 dual D flip flop used to count down a crystal oscillator to generate the $\Phi 1$ and $\Phi 2$ clocks. This flip flop is wired as a toggle to divide the master oscillator by two. This is the beginning of the clock generating logic on the original SWTPC system.

The slow memory interface is inserted at the beginning of the $\Phi 1$ and $\Phi 2$ timing logic. At the heart of the circuit is IC2, a 7474 dual D flip flop synchronizer and IC3, a 7408 AND gate. The slow memory interface is inactive as long as there are no clock

pulses on IC2a, pin 11. In this state, pin 1 of IC3 is always high, thus allowing the system clock to propagate directly through the $\Phi 1$ and $\Phi 2$ logic.

The stretching of $\Phi 2$ is accomplished by the rising edge of the slow memory line on pin 11 of IC2a. The slow memory line is derived on the memory card that contains the slow memory device, and should be a "wired OR" sum of all slow memories in your system. The only time you want to generate the slow memory signal is when you address such a slow memory element. Therefore, you must AND $\Phi 2$ with the address decode for that memory along with VMA. I suggest you use a three state or open collector AND gate to drive slow memory so you can bus several memories together and share the same slow memory line. Use the address decode for these memories to enable the signal.

The rising edge of slow memory clocks IC2a and places a logic 0 on \overline{Q} , pin 8. This

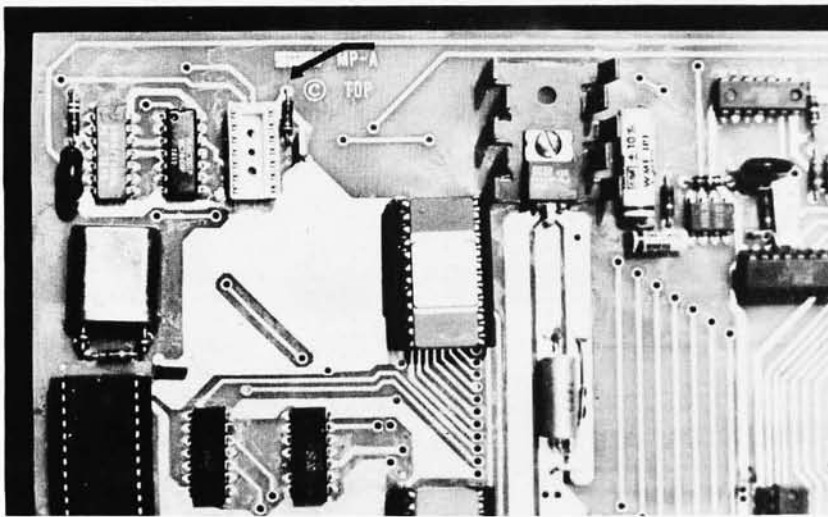

Photo 2a: Location of the IC20 socket on the Southwest Technical Products 6800 MPU board. The arrow shows the position where IC20 has been replaced by a dual in line socket with 14 pins.

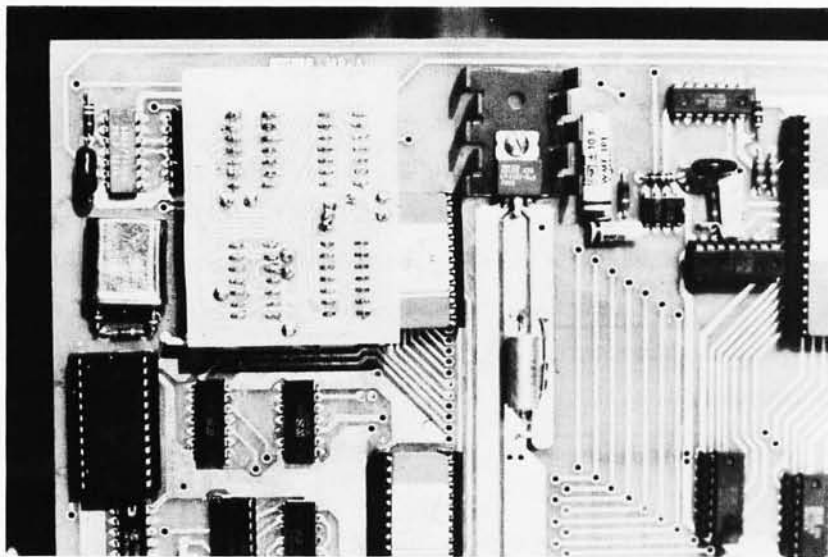

Photo 2b: A view of the slow memory interface board installed in position on the Southwest Technical Products 6800 MPU board.

Acknowledgment

The author wishes to express his gratitude to Ned Mayrath of Mayrath and Associates for his inputs and editorial assistance in the preparation of this article.

forces the output of IC3 pin 3 to go low and holds the processor in the $\Phi 2$ state. Note: A logic 0 on pin 3 of IC3 is equivalent to a $\Phi 2$ cycle and conversely a logic 1 on pin 3 is equivalent to a $\Phi 1$ cycle. On the next clock cycle, IC1 pin 6 goes low and does not clock IC2b. The following clock causes IC1 pin 6 to go high and clocks IC2b; this in turn resets IC2a by placing a logic 0 on the reset line pin 13. Since IC2a is reset, the \bar{Q} output of IC2a pin 8 is high and thus enables IC3 by placing a logic 1 on pin 1. At this point the clocks are back to normal operation and will remain at full speed until another access is made to a slow memory element. Refer to photo 1 for a timing diagram of this operation.

Modifications to the SWTPC 6800 MPU Board

You must remove IC20 from the SWTPC MPU board. Refer to photo 2a for the location of this integrated circuit. I suggest that you replace IC20 with a 14 pin DIP socket to aid in parts replacement should a component failure occur. You might solder the slow memory interface directly into the IC20 position if you wish to live dangerously. Notice there is no connection to pin 8 of IC20. You must add a wire from IC20 pin 8 to one of the user designated pins on the SWTPC 6800 MPU board. I used UD1 for my system. This user designated line now becomes my slow memory line.

If you replaced IC20 with an integrated circuit socket, simply plug the slow memory interface printed circuit board into the socket via the component carrier. Position the printed circuit board as shown in photo 2b with the foil side up. If you didn't use a socket, you must solder the interface into place. This completes the modifications to the SWTPC 6800 MPU board. Photo 2b shows the installed slow memory interface.

Conclusion

This slow memory scheme should provide the M6800 user a much needed addition to make his system as flexible as possible. This technique can be used to interface slow peripheral devices to your system. The modification to the SWTPC MPU module is very simple and clean. You don't have to cut and hack the printed circuit board. The only modification is the addition of one wire and the replacing of one integrated circuit with the printed circuit board described. ■

SYNCHRO-SOUND ENTERPRISES

PRESENTS

ADM-3 KIT

LSI-11

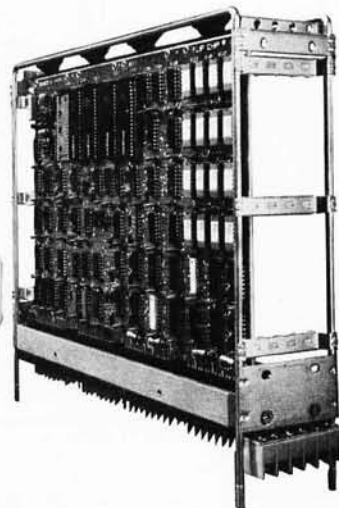

24 line X 80 column
VIDEO TERMINAL KIT

16 BIT MICROPROCESSOR
400 MACHINE INSTRUCTIONS
with 4K X 16 RAM

WINTER SPECIALS

ADM-3K \$849.95

LSI-11 \$840.00

IMSAI 8080 \$559.95

FEATURING THE FOLLOWING PRODUCTS

LEAR SIEGLER

IMS ASSOCIATES, INC.

CROMEMCO

SOUTHWEST TECHNICAL PRODUCTS

TECHNICAL DESIGN LABS (Z-80)

DIGITAL EQUIPMENT CORPORATION

DEC WRITERS

PROCESSOR TECHNOLOGY

"SEALS" RAM BOARDS

OLIVER AUDIO ENGINEERING

WORKING MODELS ON DISPLAY AT OUR NEW SHOWROOM

CALL OR WRITE FOR

DISCOUNT PRICE LIST

PHONE ORDERS

(212) 468-7067

STORE HOURS SAT (9AM-4PM)

WEEKDAYS CALL

SYNCHRO-SOUND ENTERPRISES

193-25 JAMAICA AV

HOLLIS NY 11423



HANDS ON!

HANDS ON! is a new newsletter emanating from the Technical Education Research Centers (TERC), a nonprofit, public service corporation, a major curriculum developer for technical education.

HANDS ON! is a project of the TERC's Northeast Curriculum Development Laboratory located at 575 Technology Sq, Cambridge MA 02139. An editorial by Robert F Tinker says: "With this publication we launch an experiment in the improvement of science education. We hope that this newsletter will grow into a grass roots cooperative venture among educators who have ideas to share on ways to bring reality and practicality into teaching." Some of the articles included in the first issue are "ICs Workshop for Junior High," "Laser/Electro-Optics Technology," "Starting Small with Micros," and more. For more information write to Robert F Tinker at the above address.

ON-LINE

ON-LINE is a buy and sell forum for the computer hobbyist. Published by D H Beetle, it lists commercial and noncommercial classified advertisements, and is mailed every three weeks or 18 times a year. Subscriptions are \$1 for four issues, \$3.75 for one year, and \$7 for 36 issues. Write *ON-LINE*, 24695 Santa Cruz Hwy, Los Gatos CA 95030.

Davenport IA-Rock Island IL Area

Bill Bangasser, (319) 326-2147, is interested in contacting computer hobbyists in the Quad Cities area. Write: POB 4133, Davenport IA 52808.

Central Texas Computer Association

Jay Bell, editor, and Ray McCoy, president of the Central Texas Computer Association, has sent us *PRINT-OUT*, volume 1, number 1, August. This well printed newsletter of 16 pages included several articles, "How to Stop a Micro-computer," by George Morrow; "The Intecolor 8001," by David M Philips; and "Up Your VDM," by Jay Bell, along with reviews of six computer hobbyist magazines and journals, and much more.

The club would like to extend an open invitation to anyone in the area to communicate with them, join the organization, or just come and visit. Its primary purpose is educating any interested persons in the computer arts and sciences, making group purchases, and helping the community in whatever way it can.

All interested parties should address R D McCoy, 508 Blueberry Hill, Austin TX 78745, or phone (512) 443-0971.

Clubs and Newsletters

Fayetteville-Fort Bragg NC

Robert G Lloyd and some friends have formed the Fayetteville-Fort Bragg Computer Club. Robert has a KIM-1 and another member is trying to get started on an 8080. Anyone who would like more information should write the club c/o Robert G Lloyd, 7554 Southgate Rd, Fayetteville NC 28304, or phone (919) 867-5822.

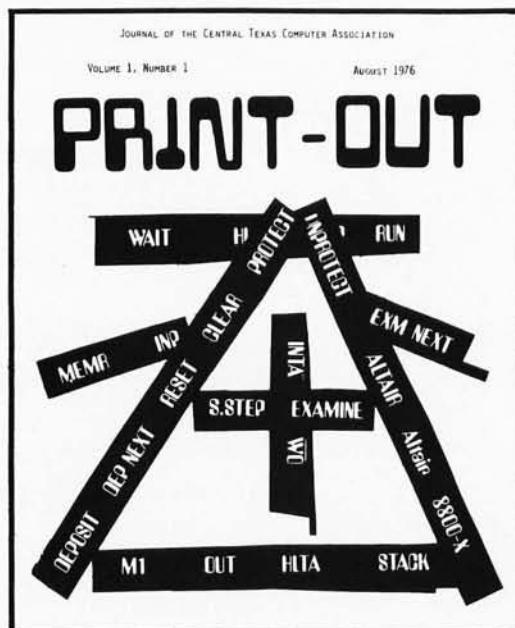

Phoenix AZ Getting Under Way

Scott Jarol writes that he and his friend Mark Kailor have been exchanging ideas about computing for some time now, and have decided to establish a computer club in the Phoenix area. Anyone interested in helping them get this club under way should write or call Scott at 3701 E Shaw Butte Dr, Phoenix AZ 85028, (312) 996-1695.

Birmingham AL

Jim Anderson, 3905 Shannon Ln, Birmingham AL 35213, writes that he is interested in contacting other computer enthusiasts in the area, particularly those with 6800 based systems, to share fun and frustrations getting one up and running. This is one way area clubs get started, so write Jim, and let's see what develops.

National Semiconductor Newsletter

The National Semiconductor Corp publishes a newsletter called *COMPUTE*; the editors are Georgia Marszalek and Dale Graves. This publication is open to all users of microprocessors for a one time fee of \$15. For more information write or phone *COMPUTE*, National Semiconductor/470, 2900 Semiconductor Dr, Santa Clara CA 95051, (408) 737-5000. ■

INTERESTED IN FLOPPY DISKS?

CP/M is a low-cost control program for microcomputers which brings together recent advances in computer and peripheral technology. CP/M is an advanced disk operating system designed for use with IBM-compatible diskette-based computer systems which employ the Intel 8080 microcomputer. Previously available only to OEM's, CP/M has been in existence for over two years in various manufacturers' products, and has undergone extensive field testing. The functions of this software package include named dynamic files, program editing, assembly, debugging, batch processing, and instantaneous program loading, resulting in facilities similar to popular timesharing services. CP/M is adaptable to any 8080-based computer system with a minimum of 16K of main memory and one or two IBM-compatible disk drives. Find out about CP/M:

- Send me the price list and free brochure describing CP/M facilities.
- I have enclosed \$5.00 for the "CP/M Features and Facilities" manual (California residents, please add 6% Sales Tax).

Name _____
 Street _____
 City _____ State _____ Zip _____

DIGITAL RESEARCH

Box 579 Pacific Grove, California 93950

New and Used Electronic Surplus

- CRT Terminals
- Peripherals
- Electronic Assemblies
- Components



Tape Drives – None Higher than \$1195

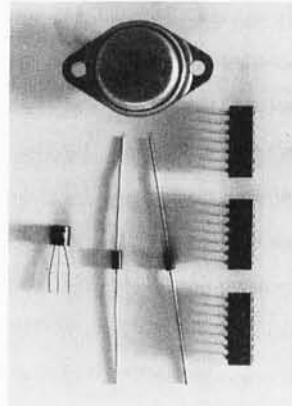

Keyboards – None Higher than \$40

Components – Power Transistors, Diodes, Integrated Circuits – from 10 Cents

Send for a free catalog or
 Call toll free 800 258-1036
 in NH 603 885-3705
 Come to our Showroom

VOLUME AND INSTITUTIONAL DISCOUNTS AVAILABLE

WORLDWIDE ELECTRONICS INC.

10 Flagstone Drive, Hudson, New Hampshire 03051
Send my free catalog to

NAME: _____

ADDRESS: _____

I'm especially interested in:

- | | |
|--------------------------------|--------------------------------------|
| <input type="checkbox"/> NEW | <input type="checkbox"/> TERMINALS |
| <input type="checkbox"/> USED | <input type="checkbox"/> PERIPHERALS |
| <input type="checkbox"/> AS IS | <input type="checkbox"/> COMPONENTS |
| | <input type="checkbox"/> ASSEMBLIES |

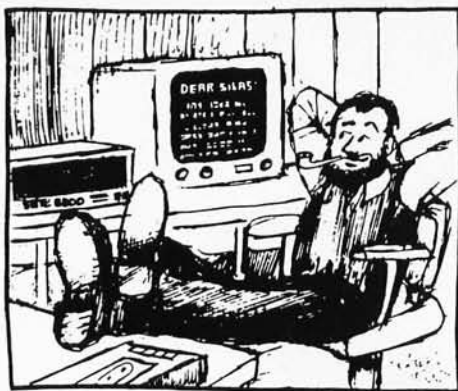

Letters

ACE IN THE HOLE (OR ELECTRON)?

Bryan Patterson in the October BYTE notes that amateur radio operators are known as "hams." He suggests that a similar name be designated for the amateur computer enthusiast. May we suggest ACE?

James E Hubbell
4719 Squire Dr
Indianapolis IN 46241

Yes.

COMMENTS ON DESIGN EVOLUTION

I fully concur with Webb Simmons (October 1976 BYTE) that the PDP-8 is an obsolete design. This opens up the question of design obsolescence. There are still some Intel 4004s around (working in simple control systems), but no one is going to put anything less than an 8080 into new systems because the price to performance ratio is so much better. Performance includes things like speed, reliability, size and power of the instruction set, and number of bits per byte. As Simmons says, 12 bits are either 4 too many or 4 too few, and nobody designs 12 bit machines nowadays. Few present day hackers will need more than 8 bit bytes and 16 bit addresses. The important difference between chips is in the instruction set, or rather in part of it since all have a large core of similar instructions. A good set is one that experts enjoy using; it is also likely to allow

amateurs to write fast, efficient, bug-free programs with relative ease. The DEC vs Data General case cited by Simmons is only one of many instances of designers leaving one company and going off elsewhere to create what they believe will be a better machine. Other examples are the Motorola (6800) to MOS Technology (6502) and the Intel (8080) to Zilog (Z-80) moves.

All microprocessors (except the IM6100) have quite good instruction sets. Some sets allow one kind of operation to be done faster than others, while another kind may be done slower. Ideally, important operations should be the fastest, and the problem is in deciding (at the design stage) what operations are important. The 6800 allows one to clear any memory location with 2 or 3 program bytes, while the 6502 (whose designers thought this operation less important) needs 4 or 5 bytes. On the other hand, the 6502 has one byte instructions to transfer the content of its accumulator to or from either of its two index registers, while the 6800 needs 4 bytes to do such transfers indirectly, from one register to memory and from memory to another register. Differences of this kind exist in all microprocessor designs. The larger set of the Z-80 allows it to do more things with fewer bytes, but competitors will surely add some of the more valuable Z-80 elements to their own chips if they have room for expansion.

Any of the modern designs will code and run most algorithms on the average about equally well. Benchmark problems can be devised that will make any one chip look better than any other, by playing on its strengths, but this only proves that for some kinds of problems one design will be somewhat better. The furor about instruction sets involves the harder question, whether one design will average out better for more of the complex problems microprocessors are going to be asked to solve. No one can answer that without knowing what these problems will be and also being able to estimate performance by looking at the design. Like it or not, the software priesthood (disparaged unfairly in your article by Wilber and Fylstra) will be needed and called on by business executives to guide their decisions. The real trial of all these chips will be in commercial uses, where the best price to performance ratio will be decisive.

HT Gordon
641 Paloma Av
Oakland CA 94610

IF YOU'VE GOT A PDP-8, USE IT!

I am fifteen, and I have been programming since I was eleven. All of it was on a DEC PDP-8/I. The machine is located at Ripon College, and our high school buys us time and a terminal. Since I do not have to pay for any of this, I have access to a very good system that doesn't cost me a dime. Since last year, I have been spending up to four hours daily running the machine.

I read Mr Simmons' letter on the PDP-8 in your October issue. Certainly I feel that he is much more experienced than I am. However, I love that PDP-8, and I want to stand up and defend it from people who say that I should get rid of it and get something better.

True, the PDP-8 is old (as computers go), and the memory is a mess as far as addressing. The PDP-8/I can address up to 32 K; however, the TSS timesharing monitor limits each user to 4 K so that there will be enough memory to go around. For those users who want a personal computer, not a timesharing machine, you can do with 32 K, and write your own monitor, too. Besides, how many of you who have a capacity for 64 K really have all 64 K?

As Mr Simmons said, the PDP-8 and ROM do not get along together at all if you have to use subroutines. Which means that you use programmable memory. Which means that you lose all your data in a power failure. Which brings us to mass storage.

Our system is very fortunate. We have a disk and three Dectape drives. I would like to emphasize one important fact about Dectape compared to conventional magnetic tape and the cassette systems. *Dectape is addressable.* Conventional magnetic tape and cassette are not. That means that you can use the Dectape for your system device and put all the programs, like BASIC, and FOCAL, on it, and then buy a limited amount of programmable memory to use as the working memory. With conventional tape or cassette, you would have to have one program per tape, and do the sorting of tapes yourself. That is time consuming at best and intolerable at worst. So you want the computer to do it. You will be required to buy enough memory to hold the entire contents of the tape, plus a tape directory, indicating where on the tape each program may be found. You will have to copy each program on the tape, and then select the one you want from your programmable memory. Most microprocessors don't have enough addressing capability to do that, and you certainly would not want to buy enough memory if your microprocessors could handle it. So all this must be made up for by software. Any way you look at it, it's a lot of work and money.

Concerning the wealth of data available from DECUS, there Mr Simmons is right. An enormous amount of programs have been written for the PDP-8, and they range from small Space War games to complex monitors. I do not yet have my own personal computer, but when I get one I plan to obtain software from DECUS. Even though their software will not run in a Z-80, I will buy BASIC from them and then rewrite it for my device. I would suggest that other users with access to DECUS look into a similar approach. Even if you are not able to read

When I became a charter subscriber to BYTE, I thought I was risking my money to some extent. Here's my vote of confidence - a 3 year's subscription. Thanks for such quality and quantity of information. I have more confidence in BYTE than the dollar!

BYTE: The Small Systems Journal

SUBSCRIPTION RENEWAL INVOICE

YOUR SUBSCRIPTION IS EXPIRING!

For your convenience in renewing your BYTE subscription, this Memo Invoice is furnished. Simply return it with your payment to insure uninterrupted delivery. Please indicate the term desired.

005118 7609P12
RICHARD R. KENYON
18605 A DEL RIG PL
CERRITOS CA 90701

BYTE

PRICE SCHEDULE

- 1 Year \$12
 2 Years \$22
 3 Years \$30

IMPORTANT: PLEASE RETURN THIS NOTICE WITH YOUR REMITTANCE.

BYTE Publications, Inc. 70 MAIN STREET, PETERBOROUGH, N. H. 03458

PDP-8 assembly language, I would urge you to learn, because of the vast amount of savings possible using this approach. A good 12 K BASIC costs about \$150, if you buy all your hardware from the same manufacturer that sold you your software. On the other hand, to buy 12 K BASIC from DECUS will not cost you nearly that, even if you have to buy a DEC manual to understand it.

I would like to remind Mr. Simmons that there are those of us who have become attached to our machines, and are not going to part with them just because someone says that they aren't the best on the market.

David Hayes
537 Hall St
Ripon WI 54971

With the prices of PDP-8s tumbling on the surplus and used computer markets, there is a point at which the use of such a machine (or other used traditional minicomputers) becomes quite attractive to small systems hackers.

STATIC

THIS IS A REQUEST FOR YOU TO REEVALUATE YOUR RECENT SWITCH FROM A PUBLICATION DEVOTED PRIMARILY TO SMALL COMPUTERS TO ONE ATTILN AT THE MAGIC AMATEUR. I THINK THIS SWITCH IS A MISTAKE.

I CAN SEE WHERE THE ADVANTAGES TO YOUR REORGANIZATION WOULD BEAN OVERWHELMING. THERE IS OF COURSE YOUR CLOSE TIES WITH "T3" AND ALSO OF COURSE MANY OF YOUR STAFF I AM SURE ARE BOTH HANDS AND COMPUTER ENTHUSIASTS. ALSO BY ENLARGING THE POTENTIAL AUDIENCE, ONE CAN SELL MORE MAGAZINES. PERHAP LATELY THERE HAVE NOT BEEN ENOUGH ARTICLES CONCERNING COMPUTERS TO FILL THE PAGES FOR ALL THE ADVERTISING ONE WANE. SO MAKE YOUR DECISION AND BASED ON A COMBINATION OF ALL OF THESE. IN ANY CASE, I THINK THE DECISION TO "GO AMATEUR" WAS A POOR ONE AND WOULD LIME THE OPPORTUNITY TO READ MY CASE.

TO BEGIN WITH, LET ME SAY THAT I HAVE BEEN INTO ELECTRONICS FOR A LONG TIME. IN ALL OF THAT TIME, I HAVE NOT BEEN AN AMATEUR WHO WANTED TO BE. I JUST DO NOT CARE FOR THE OPERATIONS WHICH WANE INDULGE IN. NOT EVERYONE TO HIS OWN.

WHEN THE HONORARY COMPUTER CASE ALOWS, I SUGGESTED TO THE TRIPITATION AND NOW HAVE A PART-TIME SYSTEM. AND I HAVE ENJOYED THE HONRY. NOT IF IT IS GOING TO BE TAKEN OVER BY MEAN, THEN I THINK I WILL LOOK AROUND FOR SOMETHING ELSE.

I AM NOT DENYING THAT SOME WHO ARE INTERESTED MIGHT NEED EDUCATING IN DIGITAL TECHNIQUES. BUT IN THAT CASE, WHY NOT USE THE PAGES OF THE MAGAZINE ALREADY IN THEIR FIELD TO EDUCATE THEM? THE SPACE DEVOTED TO THE HANS COULD BE INSTEAD USED TO GOOD ADVANTAGE BY THE COMPUTER GUYS AND EDUCATING US.

I DO NOT DOUBT THAT HANDLING HORSE IS NON-TRIVIAL. BUT THERE ARE MANY PROBLEMS WHICH ARE NON-TRIVIAL WHICH LEAVE ME COLE. I DOUBT THAT THE CRITERIA FOR INCLUDING AN ARTICLE IN THE SHOULD BE ON THE BASIS OF WHETHER IT IS NON-TRIVIAL. IF YOU ARE GOING TO USE THAT AS A BASIS, HOW ABOUT AN ARTICLE DISCUSSING THE DELIVERANCE OF HEALTH CARE IN THE UNITED STATES? THIS IS A NON-TRIVIAL SUBJECT MIT ONE WHICH YOU PROBABLY WOULD NOT CONSIDER.

I MADE AN ANALYSIS OF THE OCTOBER 1976 ISSUE. THE RESULTS OF THIS ANALYSIS IS AS FOLLOWS:

ADVERTISING	= 60.83 PAGES	= 41.14
AMATEUR TEXT	= 29.67 "	= 26.84
NON-AMATEUR TEXT	= 47.50 "	= 32.12
TOTALS	148.00 PAGES	100.00

SINCE THIS WAS MY FIRST ANALYSIS OF THE CONTENTS OF A MAGAZINE, I HAVE NO STANDARDS OF COMPARISON AS TO ADVERTISING TO TEXT RATIOS WHICH ARE CUSTOMARY. HOWEVER, I DO FEEL STRONGLY ABOUT THE 27% AMATEUR TO 32% NON-AMATEUR RATIO. IF THIS IS GOING TO BE YOUR NEW POLICY, THEN I THINK YOU STAND TO LOSE MORE THAN GAIN.

I DO NOT KNOW HOW MANY COMPUTER ENTHUSIASTS ARE ALSO HANS. BUT FROM GENERAL OBSERVATION, I WOULD SAY NOT MANY. I INTEND TO ASK THE SECTION AT THE NEXT MEETING OF THE HONORARY COMPUTER CLUB AND GET AN INDICATION. IF YOU ARE INTERESTED, I WILL WRITE YOU THE RESULTS OF MY SURVEY.

ENCLOSED IS A DETAILED BREAKDOWN OF THE ANALYSIS MENTIONED ABOVE.

SINCERELY YOURS,

Robert L. Edens

ROBERT L. EDENS
1096 V. REMINGTON DR.
SUNNYVALE, CALIF. 94087

Come on now, Robert. One sample hardly a trend makes. Have you ever thought that maybe there might be a little art and craft in making an issue have a theme which changes with each coming month and keeps readers wondering what they'll see next? You'll probably complain about November also, with its excessive concentration on graphics topics.

HIGH LEVEL LANGUAGE COMMENTS

The first two letters in the August issue struck my interest. To Peter Skye go my best wishes for such an ambitious undertaking (apparently by himself, too). One nifty feature he could include in his compiler would be to allow inline assembly code within the PL/1 (or other) program. Such a

ALTAIR & IMSAI MOTHERS DESERVE BEAUTIFUL 8K BABIES from VECTOR GRAPHIC

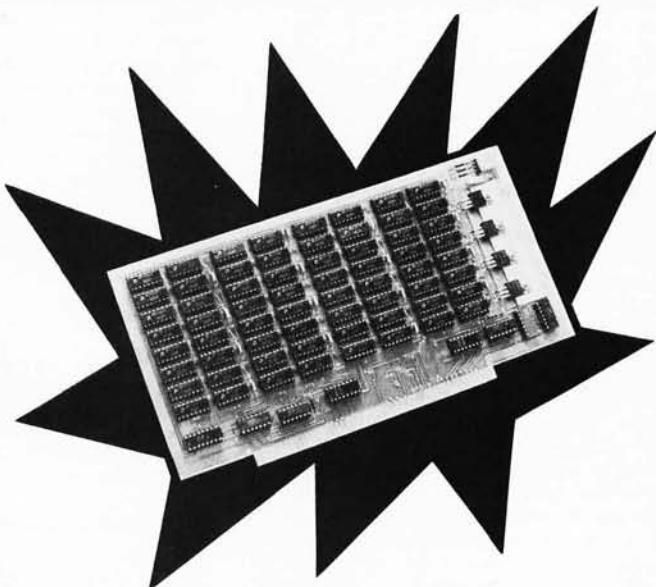

ALTAIR & IMSAI COMPATIBLE 8K RAM SPECIFICATIONS:

- Access Time: 450 ns max. current required < 200 mA/1024 words max.
- Memory Chip: low power static RAM
- Voltage supply: +5V to +10V
- Address Select: Dip switch accessible from top of board—no need to remove board to relocate
- Power Regulators: 4 ea. 7805
- Wait States: NONE! CPU runs at maximum speed
- Buffered address and data out lines
- Buffer disable line for transparent loader
- Memory protect

CLIP & ORDER TODAY

Order your 8K RAM kit for only \$265.00 + 6% Calif. sales tax .03% handling. \$350.00 assembled, includes sockets.

VECTOR GRAPHIC
P.O. BOX 4784
THOUSAND OAKS, CA 91359
TEL: (213) 889-9809

SEND _____ 8K RAM BOARDS TODAY

CHARGE TO MY CREDIT CARD.

B of A No. _____ exp. dt. _____

M.C. No. _____ exp. dt. _____

Signature _____

Name _____

Address _____

City _____ State _____ Zip _____

THE COMPUTER CO. OF THE FUTURE



P.O. BOX 4784
THOUSAND OAKS, CA 91359
TEL: (213) 889-9809

VECTOR GRAPHIC INC. T.M.

feature could be implemented "lebentleben" ways and would be very useful at times.

And in reference to Don B Keek's letter on an interpretive translator/emulator, what he describes is indeed an *interpreter*. A *software* interpreter (there are hardware interpreters) is a computer program which accepts, as input, a program (source code) in another language and for each statement input to the interpreter, it translates that statement into a set of machine instructions and then executes those instructions. Usually the use of interpreters is regarded as inefficient because (1) the source code must be stored (which usually takes more space than the equivalent machine instructions), and (2) each statement must be translated each time it is encountered. It must be noted, however, that there are advantages to using interpreters, but I'll not discuss that here.

Instead, let me suggest that compilers would be more useful. A compiler translates a problem-oriented language (say PDP-8 PAL) into a set of machine instructions (say 8080 machine instructions) for execution at some later time. Although one usually associates compilers with high level languages such as FORTRAN, there is no restriction, really, as to their use. An assembler can be considered a compiler, but by convention an assembler is defined to be a program which translates only a symbolic representation of machine language into actual machine instructions. Finally, the PDP-8's 12 bit word should not infer inefficiency with respect to 8 bit microcomputers. It would depend upon the actual application of the original PAL program, of course, but in general I would suspect that allocating only one 8 bit word for each 12 bit PDP-8 word for data storage would be sufficient. And for those cases where just an 8 bit word would raise problems, go ahead and splurge with two bytes!

Earl P Weaver
Computer Consulting
PACE Associates
2302 Titan Ter
Havre de Grace MD 21078

SECOND LAW OF THERMODYNAMICS APPLIED TO MAILING LISTS

(Paraphrased: TANSTAAFL)

The following good humored note was sent back to us on a BYTE subscription promotion letter.

How come the "sales pitch." I'm a Charter Subscriber to BYTE from issue 1 and I've renewed for two additional years. So what gives? Maybe computers aren't so "hot" after all.

PS: This is the third promotional letter I've received so far from you.

John Hitt KOKFV

Well, John, it's a matter of economics. It costs X amount of dollars to send a redundant letter to you, and several others, versus Y amount of dollars to coordinate and run what is called a "merge/purge" operation on lists obtained from various sources. If Y is greater than X by a significant amount, as is the case, then it is obvious which course of

action will prove most cost effective. Actually, we've heard more complaints about the lack of promotion for BYTE (that we have to be found out about on the "grapevine," as it were) than about too much direct mail marketing of subscriptions.

BACK ISSUES?

May I compliment you for your superb publication. I am a recent subscriber, and having received thus far only three issues, I am very impressed with your publication's consistent quality. Your articles are informative, practical and especially crystal clear in their presentation.

I would very much like to complete my library of BYTE, and would appreciate being advised on the availability of the following back issues: September through December - 1975. January through June - 1976.

Peter Raiti
40-16 Ithaca St
Elmhurst NY 11373

Sorry, Peter, we're all sold out of back issues through September at this time. We expect eventually to see the editorial content in print in the form of books, and arrangements will be made for microfilm versions of all the back issues.

AN INFORMAL NEW PRODUCT RELEASE

As a matter of news, let us take this opportunity to inform you of the beginning of a new company devoted entirely to microprocessor software. We hope to make available a variety of software products in the near future at reasonable prices. Source code versions will be available to commercial interests (nondisclosure agreements will be mandatory, however) and special binary versions will be available to hobbyists on both cassette and paper tapes, thus making quality software available to the hobbyist for the first time.

We mention this in lieu of sending you a formal news release in the hopes that as a service to your readers you might mention our name. Our initial offering will include a powerful and sophisticated macro assembler (yet still one pass!) that generates relocatable binary code and features global and local symbol capability, unlimited macro nesting, and much more. A complimentary linking loader is also included with the package.

Also available now is a fast and accurate (uses BCD arithmetic for accuracy) floating point processor. Twelve digit mantissas, exponents from -127 to +127, and the capability to implement imaginary numbers also, are all included in the system. Also included at no extra charge are all library functions! Sine, cosine, tangent and their hyperbolic counterparts, $\log_e X, e^X, a^X$, and all logical operators. Also included are formatting routines and a reverse Polish stack operating system, plus conversion routines (ASCII to FPP and vice versa) and much more!!

A very powerful debugging program has just been completed that can significantly reduce the time and effort spent in this tedious procedure. It is easily comparable to systems available only on much larger machines and features tracing, symbolic addressing, location monitoring, logical opera-

tions, multiple break points, etc. We think your readers would like to know. Thanks.

Stephen M Freeman
Managing Partner
Freeman Associates
POB 859
Hopkinsville, KY 42240

HEXABUS?

In the July 1976 issue of BYTE on page 102 is mentioned a hexadecimal calculator called "Hexadat." I want to inform you that an equivalent calculator has been on the market for approximately 3000 years. My abacus has 13 rows of 2 and 5 beads. The combination is sufficient to represent any digit in any base up to 16, including bases 2,4,8 and 10. By assigning appropriate weights to the upper 2 beads, they form subdigits.

In base 10, the two beads are weighted 5 each, which allows a carry of 5 out of any position before having to carry things in your head. By using the same weighting, one can work in hexadecimal but you have to carry some things in your head. Base eight uses a weighting of one for each bead. Bases 1, 2 and 3 can be done on the top row, and 4 and 5 on the lower row. That really isn't bad for a calculator that cost me \$4.95 plus tax.

Robert Dagleish
Box 281 Sub 6
Saskatoon Saskatchewan
CANADA S7N 0W0

But you missed the point: You have to do a lot of mental manipulation to run your abacus in hexadecimal mode.

VOCAL COMMENTS

Your August issue was, as usual, filled to overflowing with good ideas and products. The two articles devoted to speech synthesis were particularly well written. Looks like talking microprocessors are on the way. As a programmer who has worked with a VOTRAX, I would like to add some comments on using a synthesizer.

The translation of English to phonemes presents an interesting challenge. There are many ways to tell your computer how to pronounce words. This includes creating pronunciation dictionaries and programming sounding-out rules from old high school English textbooks.

Many approaches have been published, notably the Bell Lab implementation on a PDP-11/45 (mentioned in the Atmar article) and at the Naval Research Lab (NRL Report 7948, Jan 21 1976, Office of Naval Research, Arlington VA 22217, written in SNOBOL). These programs have speech rules as well as a vocabulary list of exceptions. It is hoped that anyone attempting to try and develop English to Phoneme translation software will make his or her work more worthwhile by keeping a few points in mind:

- Write "synthesizer independent" code. This means using a standard set of phonemes. The 64 VOTRAX phonemes are not the same as those used by the AI1000. The Naval Lab used the International Phonetic Alphabet in its program and converted the

output to a form used by a particular synthesizer. The IPA is used in some dictionaries.

- Implementations must be fast and easily accessible by other software. It has to be callable from a big Star Trek simulation and not slow up the Warp drives.

Warren A Leach

NEW PRODUCT: SNOB DETECTOR

I have read with interest your "What's New?" column on page 78 of the August issue of BYTE. What I see between the lines of the review is a large gap developing in what should be one whole family of personal computing fans; a gap I have termed "cybersnobbery."

I refer, of course, to your article on the HP-91 calculator, by Hewlett-Packard. To wit:

Sometimes, one gets the impression that all the manufacturers of programmable (and non-programmable) calculators have gotten together and agreed to have a calculator a month hit the market.

And:

Will the calculator a month trend continue? Read the next BYTE and find out. Maybe HP will take the HP-55, put it into a case with a printer and batteries, and call the result a portable desk top programmable machine.

Both these statements demonstrate the negative attitude the personal computing community apparently has toward the calculator field, and a prime example of cybersnobbery. It also, I venture to say, shows the inexperience of the reviewer.

The reviewer suggests that maybe HP might produce a programmable desk top unit of similar design to the HP-91. Naturally they would . . . that idea alone had been raised and agreed upon by several P2C (Programmable Pocket Calculator) owners

some months ago. Next the reviewer suggests further that it will be a desk top version of the HP-55. Anyone at all who knows anything about P2Cs would know that would be the last machine HP would make into a desk top unit. The HP-55 was mainly a pre-programmed calculator with, as one of its features, the ability to store and execute limited programs. It was never meant to be a contender as an excellent programmable machine.

A more realistic suggestion would have been putting the HP-65 in a desk top unit. At least there, the user would have some versatility. As it turns out, of course, HP is releasing a new breed of calculator, one of which will be the desk top unit, the HP-97.

Since it is becoming exceedingly clear that those who put down these pocket miracles have little or no idea as to how powerful P2Cs are, let me cite a few examples.

In 100 6 bit instructions, I can load in a program that will perform "Parallax Transformations in a Celestial Reference System." How about a game of Hexpawn or CyberNimb, both games that learn as you play them. I can also balance my checkbook, perform trend line analysis, compute components for a Chebyshev filter, check male pulmonary functions, navigate a ship, fly a plane by one or two VORs, have a game of Hangman using an alphabetic overlay of the keys, or simulate a dime slot machine that duplicates standard payoffs. All on the HP-65.

An owner of the SR-52 has the ability to do binary searches; linked lists; manipulation of subscripted variables and arrays; interrupt processing; dynamic code modification; op code translations; linked editing, loading and execution; overlays paging and even output graphics with the attachable printer. With the new HP-67/97 line, even more advanced programming is possible, including software control of chaining programs too long to fit into program memory.

It also appears from the article that the reviewer is a bit dismayed by the fact so many calculators are showing up on the

market. I've never seen anyone yet complain because new microprocessor systems and accessories appear almost daily, however. What would have happened if companies like Intel had stopped with the 8008 and the like? Let us hope the calculator a month trend, as well as the cheaper memory cards and the new systems trends, continue for some time.

As a final proof to the abilities of the lowly P2Cs, I offer a program [page 29] written for the SR-52 with attachable printer. The program will play a game of SHOOTING STARS, as first described in the May issue of BYTE [page 42]. The rules for play are the same and I refer any user to that issue for full play instructions. Naturally, alphabetic output is not possible, but the game functions in the same manner outside of that.

I like BYTE and micros (I own one too) and I find this to be the most interesting of all hobbies; but I also like the pocket programmables and it disturbs me to see others make light of some powerful little machines.

Down with Cybersnobbery.

Craig A Pearce
2529 S Home Av
Berwyn IL 60402

NOTE: Description of possible functions capable on the SR-52 was provided by Mr Vanderburgh, editor of 52 Notes, the newsletter of the SR-52 Users Club.

Snobbery is in the eye of the beholder. Have you ever thought that maybe there is an element of amazement and fascination in the attitude against which you protest?

KUDOS FOR SWTPC

Good news ought to be shared, and my experiences in building a particular micro-processor kit may be of value to other readers. Since I hadn't undertaken any significant solid state assembly work for a long time and because I thought it would be a

CASSETTE OR FLOPPY DISK? - PERCOM GIVES YOU A CHOICE!

THE CASSETTE I/O THAT WORKS!

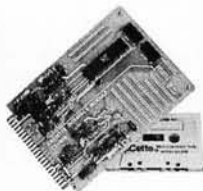

- Inexpensive mass data storage
- 28 byte/sec-upgrade to 220 b/s
- 'Kansas City'/Biphase Standard
- Self clocking-immune to tape spd
- Works with any cassette recorder
- No 'tricky' adjustments
- 25 page instruction manual

\$59.95 Kit \$72.95 Assembled

NEW! Altair/IMSAI version — add \$20.

Upgrade to 220 byte/sec \$10

Instruction manual only \$ 4

THE NEW LI'L FLOPPY!

"now you can afford a floppy!"

- Compact 3.5 x 5.75 x 9"
- 110Kbytes/diskette
- Hi speed random access
- Altair/IMSAI interface (others also available)
- 8080/6800 Software

\$695 Kit \$810 Assembled

Manual only \$10

Available Dec. '76

Delivery less than 60 days

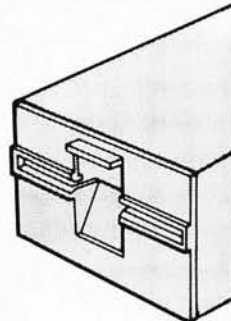

PerCom Special!
UARTs — \$6.95

Call or Write for complete specifications

Per Com Data Co.

4021 Windsor • Garland, Texas 75042 • (214) 276-1968



good opportunity to learn what I've been missing since I got an electrical engineering degree at the end of the vacuum tube days, I decided it would be reasonable to first build an oscilloscope so that I would be better equipped to track down all the problems which seem to arise when you assemble your own microprocessor.

Imagine my amazement when upon the completion of the Southwest Technical Products 6800 processor my debugging efforts were limited exclusively to checking voltage while powering up each board. The system worked as assembled! It went much better than the scope, which proved to be unnecessary.

What makes all this noteworthy is that I've talked to several (about four or five) other people who have had experience with the SWTP-6800 and all reported virtually identical experiences.

Your readers may want to know that there are differences in kits as well as differences in the skills of builders but a limited statistical sample suggests that with a good kit, the results have a high probability of success.

H Robert Knitter
533 S Segoe Rd
Madison WI 53711

AN OLD FLAME, REKYNDLED

HELP! I think a bug is trying to byte me! The personal computing bug that is.

You see once upon a time I was an operator and programmer on a Honeywell 200 series machine. I wrote in both COBOL and Assembler with what I felt was relative ease. Since then I have left the computing field to make my living elsewhere. However, my interest and love never really died.

Then, one day, I chanced to pick up a copy of your excellent magazine. Suddenly I became aware of the opportunity to renew

my love affair. Like a man married 50 years, the desire to kindle a flame was strong, but I hadn't any idea of where to begin. So, in desperation, I am turning to you for advice in hope that you are the Ann Landers of the personal computing world.

If advice is kindly forthcoming, you may judge its level of complexity on the fact that my knowledge of electronics, if not 0, is at best unaddressable.

Although my expertise is miniscule, my dreams are not. What I hope to eventually do is create a system that I may use in my business to analyze sales, do billing and track accounts receivable. I know that probably sounds like I have bugs in my memory, but my time is unlimited, my funds are not and I would like to have fun doing it.

If advice is not forthcoming, may the great god IMSAI SACRIFICE YOUR FAVORITE SOFTWARE UPON HIS ALTAIR!

Thank you for your time.

Jim Dougherty
1820 Marmaduke St
Pittsburgh PA 15212

You'll need a kit system with 8 K and 32 K of memory, a floppy disk (dual drive preferred) and a television terminal. Hard copy is also desirable for such business applications, preferably with a "forms tractor."

DAZZLED

Yours truly sure unloosed an avalanche when I put my name on that dotted line for a sample copy of your fine magazine. My biggest trouble seems to be that I retired about 11 years too soon, and made the mistake of thinking that ALL progress in the electronics field retired with me... Oh yes, I was one of those smooth "experts" from out of town who was in charge of seeing that some of RCA's electron micro-

scopes came up with 10 A₀ pictures regularly — or else — and was terminated for age in 1963. Be that as it may, my interest in all electronics except some reduced activity in ham radio fell to 0.

Main object in sending this letter is to thank you for the opportunity of seeing how the other folks in the new computer fields talk, think and write. It's about 95% over my head, and bytes, bits, PROMs, Bauds (they used to be somewhat shady ladies) to say nothing of interfaces, displays and other items too numerous to mention, are just too much for a 78 year old to try to "get back into."

So, thanks again for the opportunity of looking over a magazine which I am sure will fill a big need in its field, and take me off the mailing list to save yourselves the postage to use on gaining more converts.

C J Faulstich W4CXL
14130 Rosemary Ln #1314
Largo FL 33540

AN ADDICT CONFESSES

I have been bitten. Please send me three years more. I enjoy your magazine very much — however, the fantastic variety of hardware and software articles has made me extremely indecisive about whether to major in E² or computer science this fall.

I have no computer at the present, of my own, that is. I find it extremely pleasurable to note that the Raytheon 704 my company uses is comparable to several microcomputers (National's PACE, in particular). Maybe someday (after college, after I see a bigger paycheck, and after hardware prices go down), I would like to build my own 16 bit microcomputer.

Dan Greening
5582 Golfridge Dr
Alma MI 48801

BYTE'S BUGS

Here lies documentation of known bugs detected in previous editions of BYTE...

BYTE's Oooooops...

Author Wayne Sewell did not intend to leave the hole in listing 2, page 46, in "If Only Sam Morse Could See Us Now," October 1976 BYTE. The missing text at line 208 was traced to the "cut and paste" process of laying down a magazine page. Going back to the article file, sure enough, the following text was found in its original form...

LOC	CODE	SI	MT	SOURCE	STATEMENT
018C		C08		SINGLECH	EWU *
018C	7F 00 45	C09		CLR	HULDBYTE
018F	7F 00 04	#10		CLM	H78004
01C2		#11		SINGLOOP	EWU *
01C2	8D E1 AC	#12		JSR	H7E1AC
01C5	8D 01 14	#13		JSR	TRANSMIT
01C8	20 F8	#14		BNA	SINGLOOP
					GET NEAT CHAR
					INPUT ASCII CHARACTER INTO ACC A
					CALL C# GENERATION ROUTINE
					CLEAN OUTPUT POINT

should be tied to +5 V through a 1 k ohm (order of magnitude) resistor to protect from damage due to voltage transients. Consult the TI *TTL Data Book*, page 60, where several alternatives are discussed under the heading "Unused Inputs of Positive AND/NAND Gates."

I think publishing flaws really serves to improve the breed. Better and better designs will result. Having spent 10 years in computer hardware design, I can assure you these "trivial" points when overlooked can have nasty consequences.

Doing a great job.

Joseph J Pfeuffer
39 Forest Ln
Coram NY 11727

The way we understand it, the critical condition to avoid is the input to a TTL gate exceeding the supply voltage. Use of the 1 k (or greater) resistor as a logic 1 source or use of the output of a spare gate fixed at logic 1 is the preferred method. ■

Eugenics in Engineering

Add an "oops" to item #2 on page 100 of the July BYTE. Unused TTL inputs

EVERY PROJECT IN THIS BOOK IS ANOTHER REASON TO OWN CSC'S QT SOCKETS AND BUS STRIPS.

With QT solderless breadboarding sockets and bus strips, you can build twice the projects in half the time. Because making connections or circuit changes is as fast as pushing in — or pulling out — component leads. No special clips or jumpers required, either.

When you're building circuits just for the fun of it, you can take them apart in minutes — not hours. So you save money by re-using parts, while eliminating heat damage to expensive components. Interlocking QT Sockets and Bus Strips are infinitely expandable, too: start small and "grow" breadboards as large as you wish.

For as little as \$3.00, you can get a lot more out of your time in electronics — so why not treat yourself to a QT Socket today?

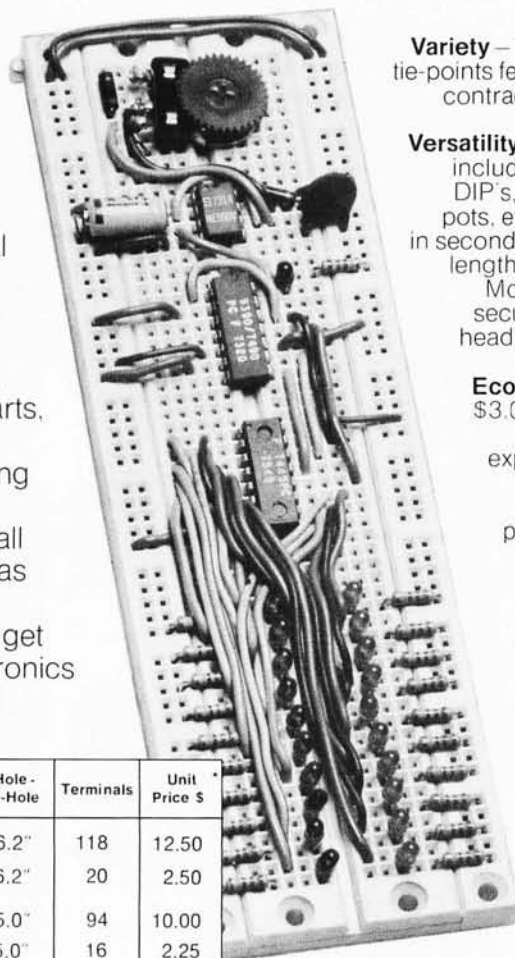

Variety — 10 models from 70 to 590 solderless tie-points feature snap/lock design to expand or contract your breadboard to fit every circuit and budget requirement.

Versatility — Use with virtually all types of parts, including resistors, capacitors, transistors, DIP's, TO-5's, LED's, transformers, relays, pots, etc. Most plug-in directly and instantly, in seconds. No special jumpers required — just lengths of #22-30 AWG solid hookup wire. Molded-in holes let you mount QT units securely on any flat surface with 4-40 flat head screws, or 6-32 self-tapping screws, from behind panel.







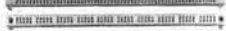

Economy — Sockets are priced as low as \$3.00*. Save more money by eliminating heat and mechanical damage to expensive parts, re-using components.

Speed — For fast circuit layouts, QT Sockets have 5 interconnecting tie-points per terminal; Bus Strips feature 2 separate rows of interconnecting terminals. Both connect and disconnect easily, without damage to socket or parts.

Visibility — All parts are instantly and easily visible and accessible, for quick signal tracing, circuit analysis and diagramming.

Durability — Higher-temperature sockets with abrasion-resistant, glass-filled plastic, rated better than 100°C. Screw-down-and-interlocked design provides high mechanical strength.

Reliability — Ruggedly designed to professional engineering standards, for heavy day-in, day-out use. Non-corrosive prestressed nickel-silver contacts insure more secure mechanical and electrical connections. Vinyl backing prevents shorting when mounted on conductive surfaces.

Length Hole-to-Hole		Length	Hole-to-Hole	Terminals	Unit Price \$
	QT-59S	6.5"	6.2"	118	12.50
	QT-59B	6.5"	6.2"	20	2.50
	QT-47S	5.3"	5.0"	94	10.00
	QT-47B	5.3"	5.0"	16	2.25
 1.32"	QT-35S	4.1"	3.8"	70	8.50
	QT-35B	4.1"	3.8"	12	2.00
 7"	QT-18S	2.4"	2.1"	36	4.75
	QT-12S	1.8"	1.5"	24	3.75
	QT-8S	1.4"	1.1"	16	3.25
	QT-7S	1.3"	1.0"	14	3.00

All QT units are .33" thick.

See your CSC dealer or call 203-624-3103 (East Coast) or 415-421-8872 (West Coast) major credit cards accepted.

*Manufacturer's suggested list • Prices and specifications subject to change without notice
© 1976, Continental Specialties Corporation

CONTINENTAL SPECIALTIES CORPORATION

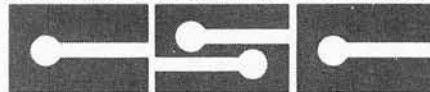

44 Kendall Street, Box 1942
New Haven, CT 06509 • 203-624-3103 TWX: 710-465-1227
West Coast office: Box 7809, San Francisco, CA 94119 • 415-421-8872
TWX: 910-372-7992

Ask BYTE

Some letters to BYTE are technical in nature and are best served by some form of response. We will try to answer as many such letters as possible. If you have a puzzle concerning some aspect of the personal computing field, write down a clear statement of your question and send it to:

Ask BYTE
 Byte Publications Inc
 70 Main St
 Peterborough NH 03458.
 We will publish names and addresses of individuals making inquiries unless you specifically request us to omit the reference. ■

Feedback

In your reply to Dr Sydney B Schrum of Goldsboro NC in the "Ask BYTE" column of July 1976 [page 95], you picked numbers which "looked 'typical'" to estimate his storage requirements. My studies on the characteristics of clinical data base files and their usage indicate that your estimated numbers are quite conservative when compared to some of the statistics that I have recently prepared.

Let's take a look at Dr Schrum's record, field by field. The enclosed table gives BYTE's estimate along with some of my statistics. Note that the total of the mean is approximately 50 percent of BYTE's estimate while the total of the 99 percentile column is roughly two-thirds of BYTE's estimate.

I assume that the patient's name is stored in one field in the format, surname, comma, given names. One to two characters can be saved by the use of a simple editing transformation which eliminates periods, trailing punctuation but not embedded punctuation, and compresses multiple blanks and blank-comma combinations. It is assumed that no decimal points, as contrasted to periods, appear in this field. The field will be longer or shorter depending upon how completely specified the users desire the given names to

be; contrast "Smith,John~~o~~Henry" to "Smith,John~~o~~H" to "Smith,J~~o~~H".

The street address field can make even better use of the above editing transformation. Note that in *most cases* the zip code completely determines the city and the state as defined by the U S Postal Service. This may differ from the actual legal definition of the city and state, but it is the correct address for postal purposes. If that is sufficient, a large compression can be achieved. Table lookup then serves to complete the generation of a printable address. This technique is used in one of the data bases designed in our laboratory. Also, note that by definition the maximum length of a place name is 13 characters when using approved postal abbreviations, add two characters for the state, and five for the zip, which sums to 20 to obtain a more conventional form of address storage. Notice that since the zip and the state codes are of fixed length no delimiters are required.

I have no comments on the telephone field other than to add that it may be necessary to provide storage for a possible extension number on a business phone.

My studies have not included pharmaceutical data storage. Yet some of my colleagues are knowledgeable in this area. I do know that several standard codes for pharmaceuticals are in existence.

Dates, and age, can be rather nicely handled as the number of days since a specific date, say since December 31, 1840. True, conversion is required upon input and output; but some very nice characteristics which facilitate searches and data verification appear in return.

I was uncertain whether the date of the last exam was the same information as the date of the present exam. Therefore, I added an extra field.

This letter touches upon a few aspects of the design of clinical data bases which have for the most part been treated in an *ad hoc* manner. The design of a useful clinical data base can be a difficult undertaking. In no way should this letter be taken as the last word on these design aspects. Careful study as to the purpose each field is to serve and the context in which it is to serve is required.

I hope that you and Dr Schrum might find this information of some value in designing clinically useful data base systems.

Table 1: Estimated Field Sizes.

Field	BYTE's Estimate	Mean ⁶	99 Percentile ⁶
Patient name	30	14	22
Street address	30	15	22
City, state, and zip	35 ¹	16 ¹	23 ¹
Zip alone	5	5	5
Street address, city, state and zip	65 ¹	32 ¹	43 ¹
Telephone	10	-2	-2
Age (Date of birth)	2	(16 bits)	(16 bits)
Rx text	30 ²	7 ³	7 ³
Date of last exam	6	16 bits	16 bits
Date of present exam	<u>16 bits</u>	<u>16 bits</u>	<u>16 bits</u>
TOTALS	145	70	91

- Notes:
1. Not counted in totals.
 2. Assume the value of 10.
 3. Assume the value of 30.
 4. All values are in bytes unless otherwise specified.
 5. Eight bits per byte are assumed.
 6. Data from Greenfield's studies.

Robert H Greenfield
 Washington University
 School of Medicine
 Biomedical Computer Laboratory
 700 S Euclid Av
 St Louis MO 63110

Acknowledgments: This work was supported in part by Grant RR 00396 from the Division of Research Resources, National Institutes of Health, and by Grant HS 00074 from the National Center for Health Services Research.

Thanks for giving us some "real world" inputs on the ways things are being done. The estimates you quoted from July BYTE were predicated upon fixed field sizes (easier to program, but wasteful) and no pretense at being optimal for the data. The zip code trick is an elegant compression, but we know from our own mailing list system that there are very real human factor problems with using that technique on large files of this sort. ■

Puzzled

I am a professional engineer, and I would greatly appreciate your help. I need to obtain a computer for use in my profession of designing engineering systems. To be frank I know absolutely nothing about computers.

I believe that there is an Altair and something from MITS which might do what I want, but I cannot find out anything about these firms and their products. Basically my need is for something that will print out the answers to reasonably simple equations with the need for calculating trig functions and perhaps Bessel functions (or storing the latter in a table), then performing the same operations with increments of 5° horizontally and 5° vertically as needed. Also a refinement would be the ability to build in discretion about the calculations on a Go-No Go basis.

But I don't know where to turn for such information. Can you help me?

(Name withheld by request)

A MITS Altair with BASIC will give you the ability to calculate trig functions, or store a Bessel function table. If you knew the analytical expressions needed to calculate the Bessel functions, that could be calculated as well. Any personal computer with an extended BASIC that has trig functions could be used, as well as any desk top calculator (programmable) with a printer accessory. Acquire a book about programming mathematical models in BASIC or FORTRAN if you want inspirations; the local college's bookstore computer science section is a good place to start. ■

THE COMPUTER ROOM

SMALL COMPUTER SYSTEMS • SOFTWARE • AMATEUR RADIO EQUIPMENT

1455-A So. 1100 E. Salt Lake City, Utah 84105 Phone: 801-466-7911

"WE TAKE THE
MYSTERY OUT OF THE **MICRO**"



One Of The Nations Largest
Full-Service Computer Stores.

Over 1600 Square Feet Of Sales
And Service Facilities.

WHEN YOU WRITE FOR OUR CATALOG AND ENCLOSE \$1 TO HELP DEFRAY THE COST OF HANDLING AND MAILING, HERE'S WHAT YOU GET:

1. A CERTIFICATE GOOD FOR \$2 ON YOUR NEXT PURCHASE

2. THE COMPUTER ROOM EASY TO UNDERSTAND CATALOG COVERING

IMSAI
THE DIGITAL GROUP
POLYMORPHIC SYSTEMS
SOUTHWEST TECHNICAL PRODUCTS CORPORATION
TECHNICAL DESIGN LABS
PROCESSOR TECHNOLOGY
ETC.

3. THE COMPUTER ROOM "EASY GUIDE" TO HELP YOU PICK THE RIGHT SYSTEM, PERIPHERALS, COMPONENTS, AND SOFTWARE FOR

THE BEGINNER
THE ADVANCED
THE EXPERT
THE SMALL BUSINESS

4. A CURRENT LISTING OF PRESENTLY AVAILABLE

SOFTWARE
PUBLICATIONS
PERIPHERALS

5. INFORMATION ON REPAIR SERVICE, LOW COST CUSTOM PROGRAMMING AND OTHER SPECIAL SERVICES.

AT THE COMPUTER ROOM YOUR WRITTEN QUESTIONS ARE HAPPILY RECEIVED AND PROMPTLY ANSWERED

**WE ALSO STOCK A COMPLETE
LINE OF AMATEUR RADIO EQUIPMENT**

BANKAMERICARD MASTERCHARGE

Don't Waste Memory Space

(One Way to Squeeze Fat Out of Text Strings)

If your system uses plenty of canned messages, chances are you're wasting valuable memory space. Most small systems are currently using a 7 bit ASCII code with one character per 8 bit byte of memory space. Why use a 7 bit code, capable of selecting 128 characters, when you really only need 64 or even 40 different characters for simple alphanumeric text? Your simple video display may only be able to handle 64 characters anyway, so why waste memory space needlessly?

By using less bits for a character code, messages can be condensed or packed in memory very easily. For example, a 6 bit ASCII code that is a subset of the standard 7 bit ASCII code allows a character set of 64 characters. The 6 bit ASCII code is easily obtained from the 7 bit code by converting all lower case letters to upper case letters and simply subtracting octal 40 from the 7 bit code (or adding octal 40 to the 7 bit

code and truncating to the rightmost 6 bits). With a 6 bit code, four characters can be packed into three 8 bit bytes of memory providing a 25% saving on the required memory storage space for a given message.

On the other hand, the normal text typing routine must be modified to unpack the compressed 6 bit character codes and convert them back to standard 7 bit ASCII for output to the terminal device. To unpack the characters, use a combination of shift (or rotate) and bit masking (logical AND) instructions, then add octal 40 to the 6 bit code to restore it to 7 bit ASCII. Unused printing characters may optionally be decoded by the typing routine and converted to special function characters such as carriage return, line feed, etc, for special applications.

Another possibility is to use a radix 40 coding scheme that provides a character set of 40 characters, packed three characters per 16 bit double byte unit of data. A typical radix 40 scheme is summarized in table 1. This scheme takes advantage of the fact that a 16 bit integer has 65,536 distinct states, while a set of three radix 40 characters has $40^3 = 64,000$ distinct states. To create a given 16 bit radix 40 three character field, X, from characters C1, C2 and C3 (assumed to be integers from 0 to 39) the following arithmetic expression must be evaluated:

$$(1) \quad X = C1*1600 + C2*40 + C3;$$

All arithmetic is assumed to be unsigned, performed with 16 bit precision for the results. Similarly, to unpack a given 16 bit radix 40 field into individual character codes, evaluate the following expressions:

$$(2) \quad C1 = X/1600;$$

$$(3) \quad C2 = (X - 1600*C1)/40;$$

$$(4) \quad C3 = (X - 1600*C1 - 40*C2);$$

Going from the radix 40 character represen-

Robert Baker
15 Windsor Dr
Atco NJ 08004

CONVERSION FORMULAS - SUMMARY

ASCII 7 bit code (X7) to 6 bit subset code (X6)

$$X6 = X7 - A;$$

or

$$X6 = (X7 \& B) + A;$$

ASCII 6 bit code (X6) to 7 bit code (X7)

$$X7 = X6 + A;$$

16 bit packed radix 40 (X) to unpacked radix 40 (C1, C2, C3):

$$C1 = X / A;$$

$$C2 = (X - A * C1) / B;$$

$$C3 = (X - A * C1 - B * C2);$$

Unpacked radix 40 (C1, C2, C3) to 16 bit packed radix 40 (X):

$$X = A * C1 + B * C2 + C3$$

C1, C2 and C3 are converted to ASCII and back using table 2.

ASCII Conversion Constants

Name	Decimal	Octal	Hex
A	32	040	20
B	63	077	3F

Radix 40 Packing Constants

Name	Decimal	Octal	Hex
A	1600	3100	640
B	40	50	28

tations C1, C2 and C3 to ASCII equivalents and back is done with a table lookup using information found in table 2 accompanying this article. For conversion to radix 40, each three character grouping of text is converted from ASCII to radix 40 values C1, C2 and C3, then formula (1) is evaluated giving the 16 bit value to be stored. For conversion from radix 40 packed storage into ASCII, formulas (2), (3) and (4) are evaluated in sequence, then the ASCII codes equivalents of the C1, C2 and C3 values are looked up in the conversion table.

Using either coding scheme you gain space by packing characters in memory but lose space elsewhere due to modified type routines to unpack and convert the codes to

Table 1: One assignment of radix 40 character values to printable graphics is provided by this table. Using 26 letters, 10 numbers and 2 special characters leaves two states unassigned. One, the value 0, is given the "null" assignment, and the other, value 29, is left open in this table. Conversion can be done between ASCII and radix 40 codes using table 2.

Character Graphic	Decimal	Hexadecimal	Octal
null	0	00	000
A	1	01	001
B	2	02	002
C	3	03	003
D	4	04	004
E	5	05	005
F	6	06	006
G	7	07	007
H	8	08	010
I	9	09	011
J	10	0A	012
K	11	0B	013
L	12	0C	014
M	13	0D	015
N	14	0E	016
O	15	0F	017
P	16	10	020
Q	17	11	021
R	18	12	022
S	19	13	023
T	20	14	024
U	21	15	025
V	22	16	026
W	23	17	027
X	24	18	030
Y	25	19	031
Z	26	1A	032
\$	27	1B	033
	28	1C	034
unused	29	1D	035
0	30	1E	036
1	31	1F	037
2	32	20	040
3	33	21	041
4	34	22	042
5	35	23	043
6	36	24	044
7	37	25	045
8	38	26	046
9	39	27	047

usable ASCII. The amount of space you gain is variable, depending on the length and number of messages to be stored, as well as the coding scheme used. On the other hand, the amount of space lost is fixed and depends only on the coding scheme used. Thus the overall saving in memory space is totally dependent on the application. The more messages you use in your system, the more memory space you can save by implementing these ideas. ■

Table 2: Equivalences between ASCII 7 bit codes, ASCII 6 bit subset codes, and radix 40 codes. This table can be used to design lookup tables for use in compressing character strings and expanding them for external formatting purposes.

Character Graphic	Standard 7 bit ASCII Code		6 bit Modified ASCII Code		Radix 40 Character Code	
	Hex	Octal	Hex	Octal	Hex	Octal
Space	20	040	00	000	00	000
!	21	041	01	001		
"	22	042	02	002		
#	23	043	03	003		
\$	24	044	04	004	1B	033
%	25	045	05	005		
&	26	046	06	006		
'	27	047	07	007		
(28	050	08	010		
)	29	051	09	011		
*	2A	052	0A	012		
+	2B	053	0B	013		
,	2C	054	0C	014		
-	2D	055	0D	015		
.	2E	056	0E	016	1C	034
/	2F	057	0F	017		
0	30	060	10	020	1E	036
1	31	061	11	021	1F	037
2	32	062	12	022	20	040
3	33	063	13	023	21	041
4	34	064	14	024	22	042
5	35	065	15	025	23	043
6	36	066	16	026	24	044
7	37	067	17	027	25	045
8	38	070	18	030	26	046
9	39	071	19	031	27	047
:	3A	072	1A	032		
;	3B	073	1B	033		
<	3C	074	1C	034		
=	3D	075	1D	035		
>	3E	076	1E	036		
?	3F	077	1F	037		
@	40	100	20	040		
A	41	101	21	041	01	001
B	42	102	22	042	02	002
C	43	103	23	043	03	003
D	44	104	24	044	04	004
E	45	105	25	045	05	005
F	46	106	26	046	06	006
G	47	107	27	047	07	007
H	48	110	28	050	08	010
I	49	111	29	051	09	011
J	4A	112	2A	052	0A	012
K	4B	113	2B	053	0B	013
L	4C	114	2C	054	0C	014
M	4D	115	2D	055	0D	015
N	4E	116	2E	056	0E	016
O	4F	117	2F	057	0F	017
P	50	120	30	060	10	020
Q	51	121	31	061	11	021
R	52	122	32	062	12	022
S	53	123	33	063	13	023
T	54	124	34	064	14	024
U	55	125	35	065	15	025
V	56	126	36	066	16	026
W	57	127	37	067	17	027
X	58	130	38	070	18	030
Y	59	131	39	071	19	031
Z	5A	132	3A	072	1A	032
[5B	133	3B	073		
\	5C	134	3C	074		
]	5D	135	3D	075		
^	5E	136	3E	076		
_	5F	137	3F	077		

What's New?

Here It Is, a Builder's Eye View of the Lear Siegler "Dumb Terminal" Kit

It's been running around the grapevine for several months now; but here it is at last, some printed word from the source concerning the "Dumb Terminal" kit of Lear Siegler, Inc.

What Lear Siegler has done is to market the first complete "glass Teletype" terminal kit in a package which can be assembled and tested at home. The only tools required are a soldering iron, needle nose pliers, wire cutters and a screwdriver (see photo 1). An illustrated set of instructions is provided to guide the builder. The terminal is marketed



Photo 1: ADM-3 kit shown in a "beauty contest" arrangement. The resulting terminal looks like the photo found on page 96 of June 1976 *BYTE*, but beauty in the eye of a kit builder is in the arrangement and packaging of the parts plus the documentation.

Photo 2: An ADM-3 builder, Kip Klappenback, working on the assembly of his terminal from the kit.



through retail outlets and has been test marketed in California stores since about June of this year prior to national marketing. At a price of \$875 retail, not much above the cost of some surplus terminals with fewer features, the purchaser gets a completely new terminal in kit form.

The ADM-3 terminal which is constructed from the kit can be used either as a direct Teletype replacement with a 20 mA current loop interface, or as an EIA RS-232C terminal. The choice is switch selectable. An auxiliary extension RS-232C port is available at extra cost to allow a serial asynchronous ASCII printer to monitor the copy on the screen with a hard printed output.

The ASCII encoded keyboard has 59 keys and causes entry on the bottom line of the screen. The display in the standard model has upper case (64 character) ASCII graphics. The page scrolls upward typewriter style following a line feed. Control functions for the display are provided by the clear screen, carriage return, line feed, space bar, backspace, and character overwrite keys. An audible tone "beeper" announces the end of line. Switch selectable options allow data rates from 75 through 19,200 bits per second. Formatting options, also switch selected, include 9, 10 and 11 bit asynchronous transmission formats; odd, even or no parity; one or two stop bits; 7 or 8 bit ASCII encoded data. All integrated circuits are socketed. The CRT and power supply come preassembled as seen in photo 2.

After assembly, the builder will have a unit measuring 12.5 inches (32 cm) high by 15.5 inches (40 cm) wide by 19 inches (48 cm) deep, with a 12 inch (30 cm) diagonal screen, 25 pound (11.3 kg) mass and power requirements of 70 watts. The data capacity is 24 lines of 80 characters each. For further information, contact Lear Siegler Inc, EID/Data Products Group, 714 N Brookhurst St, Anaheim CA 92803. (The Lear Siegler products are found in nearly every computer store in the country at the present time, if you want to take a look at one yourself.)■

For Individuals Desiring Selectric Typewriter Conversion

The only known commercial product source (circa August 1976) for a conversion of IBM Selectric typewriters into IO machines for computers is Tycom Corp, 26 Just Rd, Fairfield NJ 07006.

The product is the Holmes Tycom Selectric IO Writer, consisting of a patented (US Patent No 3,453,379 available in reprint for 50¢ or thereabouts from the US Patent Office, Washington DC) "applique" which will fit the bases of the IBM models 711, 713, 715, 721, 723, 725, 873, or 875 Selectric typewriters. According to the literature, no permanent modification of the typewriter is required, and the standard IBM maintenance contract for the typewriter plus applique assembly is available for \$42 per year. The applique can be installed on typewriters leased from IBM, and can be removed in less than five minutes.

The only problem with this mode of converting an IBM Selectric I or Selectric II typewriter to IO applications is the price. According to a brochure, it is \$1455 plus the cost of the customer's typewriter and shipping to the Tycom plant for modification.■

BYTE'S BITS

DECUS Fall Meeting

DECUS, the Digital Equipment Computer User's Society, will have its fall meeting in Las Vegas NV, December 6-9, at the MGM Grand Hotel. According to the press release, DECUS is the largest and most active computer users organization in the world. This is no doubt true, since DEC started the small computer trend with its introduction of the minicomputer (then priced in the \$100,000 range) in the early 60s, and today is the largest minicomputer company.

Of special interest to scientific researchers in the medical field is the featured technical part of the meeting, a four day symposium on the use of computers in medicine, image processing, clinical laboratory procedures and medical information systems. The 40 sessions include topics such as "A Program for Measuring Reaction Time of Human Subjects," "Minicomputer Handling of Bibliographic Information," and "The Future of Computers in Image Analysis."

For further information, contact the Digital Equipment Computer Users Society, Maynard MA 01754, phone (617) 897-5111.■

Come to the Boston IC Party?

Claiming to have the "world's largest computer store," American Used Computer Corp has opened up a retail division called the Computer Warehouse Store, located at 584 Commonwealth Av, Boston, most convenient to all the MIT beavers and other Boston area hackers. The press release copy bills it as a "computer hobbyist heaven" complete with "an abundant supply of microcomputer kits from the major kit-makers" of the world. Included are IMS Associates products, and Southwest Technical Products Corp kits among the main frames, and ancillary products from soldering irons to card readers, tape drives and Teletypes. The store also stocks Lear Siegler terminal products and Sanyo monitors. It looks as if this store would be a "must visit" entry on any computer hacker's itinerary for a visit to the Northeast.

The Computer Warehouse Store is a division of one of the oldest used computer dealers in the country, and is implemented with a 7,500 square foot retail display area with wall to wall stock of used accessory gear that includes minicomputers, commercial grade peripheral equipment, boxes and boxes of hard to find parts, etc.

And don't forget the used computers. Here is the place to go if (for some reason) you want to locate that used 1620 disk system, that old 1401 central processor, or a Memorex 40 (at pennies on the dollar). Computer Warehouse Store hours are 11 AM to 9 PM, Monday-Friday, and 9:30 AM to 5:30 PM Saturdays; 584 Commonwealth Av is located between Kenmore Square and Boston University.■

No Matter How You Stack Them Ours Comes Out On Top!

OUR FD-8 FLOPPY DISK SYSTEM interfaces to anybody's microcomputer system via a single PIA chip!

If you don't use PIA's, then one 8 bit bidirectional data port and one output only control port is all that's required — that simple! If you don't have a bidirectional port then separate input and output ports will do.

Full sector buffering in 3K of RAM contained on the controller card itself eliminates any dependence upon processor speed.

Each drive is contained in its own cabinet with power supply. Up to 4 drives may be daisy chained together and selected under software control from a single controller card.

Both single and double density, single or multiple drive units are available.

Complete F DOS software for both 8080 and 6800 systems is provided at no additional charge, including: disk driver subroutines, variable length file management system, disk assembler/editor, and integration with basic.

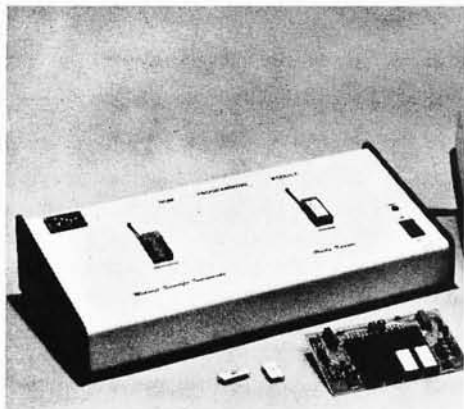

MSI introduces the PR-1 PROM Programmer and verification module for use with microprocessor systems.

The PR-1 interfaces to any microcomputer system via a single PIA chip. The unit is designed to program 1702A PROMS. Complete software for PROM programming is provided with the system at no additional charge.

MSI software products including our mini assembler, disassembler, and basic are now available on KC standard cassettes. Please specify either paper tape or cassette when ordering.

For the past 6 years MSI has been a leading manufacturer of microcomputer data handling systems for medical laboratories, so we're not new to the business. Four years ago we introduced the first floppy disk system for programmable calculators, which is still in production today. We manufacture CRT terminals, PROM programmers, and a large selection of instrumentation interfaces. For more comprehensive product information, write MSI at the address below. Incidentally, our products are ready for immediate delivery.

Master Charge & BankAmericard orders welcome.

Here are two MSI Dealers, who can show you our products in action...

Microcomputer Systems, Inc.
144 S. Dale Mabry Ave.
Tampa, Florida 33609
(813) 879-4301

American Microprocessors,
Equipment & Supply Corp.
Chicagoland Airport, P.O. Box 515
Prairie View, Illinois 60069
(312) 634-0076

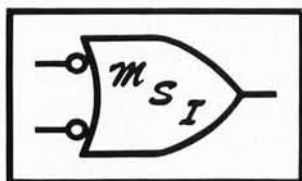

Midwest Scientific Instruments

Do It Yourself Weather Predictions

Michael R Firth
4712 Northway Dr
Dallas TX 75206

One of the most challenging tasks for a computer owner can be working up the software and hardware to permit analysis of the weather and prediction of what is coming. Whether you wish to develop some software and take readings yourself or develop the hardware and do your own analysis or have the computer carry out both tasks, you can enter into a challenging and fascinating world of computer applications.

In this article, I shall not present specific solutions for specific computers. Instead, I shall outline thinking needed in software and make suggestions about hardware. In most cases, there are alternate solutions and some of the solutions are useful for other problems (such as cycle analysis for scientific biorhythm experiments).

Software for weather prediction falls into two categories: that for gathering data and that for analysis of the data gathered. The former is partly related to the kind of data gathered and the device used, and it will be discussed along with the devices that it applies to.

Gathering Data

The general requirements for gathering data include a need to code both the data from various instruments and the time of the readings, so the analysis program will know when it was collected. Depending on how often the data is analyzed and how much is gathered, there may be a need to dump accumulated data to tape. Assuming you have enough memory for the maintenance program, the analysis program, the most recent data, and intermediate results, then you may still wish to dump to tape for analysis of longer trends. If you have limited memory, you will have to dump to tape, loading the analysis program and a tape input routine for analysis later.

If your processor is to gather data, your first task is to set the time interval at which

data is collected. Unless you want to tie up your computer as a clock, you will want to generate an interrupt from an electronic or mechanical clock. With a mechanical clock, you could conceivably create a way of turning on the computer and then automatically bootstrapping the data acquisition program. But it is probably less complicated to simply leave the computer on all the time and use an electronic real time clock.

The advantage of using the computer to gather data is that it can do it when you are asleep or at work. Upon receipt of a trigger signal, the data acquisition program executes subroutines to test each device, reads and formats the data, perhaps does some preliminary analysis, stores the data, perhaps outputs results to tape or hard copy, then goes back to resting.

If you use the most basic devices, there is little point in gathering data more often than every hour. With more accurate devices, there may be some point in gathering data every five, ten or fifteen minutes.

If you do not have an actual time input, then you can use a mechanical or solid state device to generate the input at regular intervals; and by keeping count of the intervals, you can note the time of day. The significance of various bits of data depends on the time of day it was gathered.

Forming the data will depend on the device used to gather it. Some devices might deliver concrete numbers which can be stored immediately, but most of the cheaper choices will return a value that corresponds to a voltage or resistance. The value can be converted to a number matching human experience typically in the data acquisition subroutine or with a conversion routine during analysis. Conversion basically consists of a table lookup of the received value and output, or interpolation from two entries and output. An example would be a thermistor reading in which a given resistance is

returned as a number, such as 208, which is not linearly related to temperature because of the method of reading or non-linearity of the thermistor. Within the computer, a lookup of a table based on experience (rather than expensive external hardware to create linearity) converts the reading to a temperature, perhaps 82 (degrees Fahrenheit or the equivalent Centigrade value).

While the computer could happily deal with resistance values and other odd numbers, if you stored these values for later use, any additional routines you wrote (or that others wrote for you) would be more complicated than necessary since conversions might be needed. It is better to store the data in a form you and I can relate to, such as temperature, humidity, wind velocity, and time of day and date.

Analysis

Once more than one set of data is at hand, analysis can proceed. (Well actually, with one set of data, you can do a few things, such as reporting the current values and announcing singular events like sunset and freezing, but more of that later, since prediction is our goal.)

Analysis of the data consists of computing relationships between pieces of data and then comparing them to a pattern. The pattern may be one created by the programmer or one computed from previous data. The latter is far more complicated. The pattern will be different for each part of the country and may have to be developed by using a bit of common sense.

I will use a specific example of analysis and cite a few examples of patterns and local variations. The first step is to create interval information. We do this by subtracting the previous reading from the current reading. If we are working with the temperature, the intermediate result will tell us whether the temperature is increasing or decreasing and by how much.

One pattern having to do with temperature is the daily increase in temperature from the low to high point. The analysis program can easily detect the point at which a reversal occurs. For a prediction of the high (or low) temperature, one need only add an average figure (which varies throughout the year). In midsummer in Dallas, the range is 22° F. The average range holds whether temperatures are generally above or below average; and it depends mostly on local conditions, such as distance from water, type of soil, latitude, and amount of human building in the vicinity.

If the early morning temperature is higher than normal, you can predict a higher than normal peak temperature in the afternoon. If the midafternoon temperature is lower than normal, you can predict a lower than normal temperature at night. With proper connections, this information could warn of a freezing condition and set off alarms and cause you to protect plants or pipes ahead of time. (The same alarm could be triggered when the temperature actually approached freezing.)

Besides the extremes of temperature, you can work with the pattern of variation, which often looks like a distorted sine wave. After you have gathered data for several days, you can sketch a good approximation of the curve and then can use it for analysis. If the temperature shows considerable variation from the curve, your program can report that a cold (or warm) front has passed through. Combined with other data (such as barometer readings and rain gauges), you may be able to predict rain (or snow) or other upcoming factors.

The more kinds of data you can gather, the more complex your computations and (hopefully) the more accurate your predictions. Generally it is easier to do a micro-forecast (very local) than a more general one.

You will have to examine the details of weather in your city to improve your predictions. For example, in Dallas, where I live, we have to keep a record of the barometric pressures over a period of time to decide whether a falling barometer is going to lead to rain. Normally we only get rain *after* high pressure has passed to the south of us, sweeping moisture up from the Gulf. Low pressure, unless it is very strong, normally is dry because it is pulling air out of Mexico as it approaches. By way of contrast, in western New York, a west or northwest wind, from across the Great Lakes, tends to produce considerable moisture including record winter snowfalls. This sort of factor varies considerably depending on exactly where a person lives. These local conditions face everyone, no matter where they live: mountains, bodies of water, expanses of agriculture, concrete, or industry, and latitude make their influence felt in unique ways.

Synthesis

The synthesis of a pattern by the machine is a complicated and time-consuming task and I will only outline it. Most patterns related to weather vary on a 24 hour or

Authors Take Note:

This article gives some ideas for home weather sensors; there is plenty of room for additional material on algorithm design for weather data acquisition, actual experiences of individuals building instruments such as those outlined here, and prediction algorithms.

Figure 1: Conceptual Design of Humidistat. The relative humidity of air is calculated from the physical properties of water and the difference in temperature between a "wet bulb" and a "dry bulb" thermometer. The evaporative cooling efficiency of the wet bulb temperature sensor's cotton shroud depends upon the relative humidity. A measurement cycle is started by turning on the fan, and momentarily energizing the solenoid. Then, with the fan still on, the wet bulb thermistor is allowed to stabilize its temperature. Finally, the computer reads the two analog input channels, and can proceed to calculate the temperature of each channel, then the humidity. The dry bulb temperature can also be retained as the current ambient air temperature in the weather record. For weather data, this device must be mounted outside, in a protected area which is open to the air. →

annual cycle and some of these are periodic, reaching a peak, gradually moving to a low point, then rising to a peak again. The first pieces of data to gather are the times during the day (or year) the maximum and minimum occur and the average value of the readings. Mathematically, the curve of the pattern can be approximated by a sine wave above and below the average with a period equal to a day (or year). For temperature, this might be $TEMP = (K * SIN(2\pi * (-L + T)/24) + J)$; where J is the average temperature, K is half the daily range, and L is the part of the time interval between midnight and when the curve crosses zero (average) going up, and T is the time variable.

It is unlikely that a pure sine wave will match the pattern, so that further harmonic components might have to be added to form a Fourier series representation. And that is where life gets complicated, for the computer has to calculate coefficients and compare these to actual data until the best values are found.

The purpose of the synthesis is to permit storage of a general formula and coefficients instead of several long tables of approximate values. For those who do not want to work with formulas, the lookup table approach is fine and will give acceptable results, or even very good results if the form of the pattern is messy and the formula is not worked out far enough.

Hardware

There are a number of approaches to the hardware of gathering weather data. Perhaps the most extreme would be to buy professional telemetering equipment; I won't even go into that, because of the cost, other than to mention that remote weather stations are available.

A second possibility would be to buy commercial items which provide digital output. For example, Heathkits are available which report temperature (Fahrenheit or Centigrade) and wind velocity in digits (and wind direction by lighting lights) and it would be a relatively straightforward task to decode the 7 segment readouts or get the data from some other point in the circuit

after it had been digitalized and allowance had been made for nonlinearity.

But such kits cost money, and you would not really be taking the best advantage of your computer; that is, using software to save money on hardware. So let's work on some suggestions for make-do hardware. We are concerned with temperature, humidity, wind, barometric pressure, rainfall, and time.

Temperature is taken with a thermistor, either an extremely linear one or anything else that varies with temperature. Using a method of digitizing the resistance with some form of analog to digital converter, the computer gets a number to work with, which (as I mentioned previously) it can then look up in a table to report a temperature.

Humidity

Humidity is rather more difficult. Most humidistats use human hair and only manage to open or close a switch at a specific point (like a thermostat). After much searching I found one company which makes a resistance type sensor for humidity; but at \$50 each, I'm not buying one. I suppose one solution would be to use a motor to drive a humidistat and a potentiometer, taking a resistance reading just at the point the humidistat opened, but that seems rather complicated.

Another possibility would be to compute the humidity from the wet and dry bulb temperatures measured with thermistors. The wet bulb temperature is obtained by covering a thermometer with a cotton sleeve, wetting it, passing air over it (which lowers the temperature) and taking a reading. The distance the temperature is lowered is related to the relative humidity — at 100% there is no lowering, since no evaporation occurs; at low humidity rapid evaporation occurs, lowering the temperature quite a bit.

When you take wet bulb readings by hand, you spin the thermometer. Mechanically, it is easier to blow air over the fixed thermistors. So I offer a design for a computer operated "woodpecker" (see figure 1) that dips the cotton in water (but doesn't rest there) and turns on a fan for

PHYSICAL LAYOUT

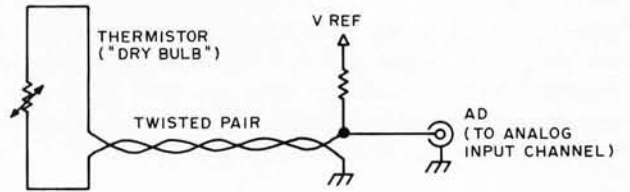
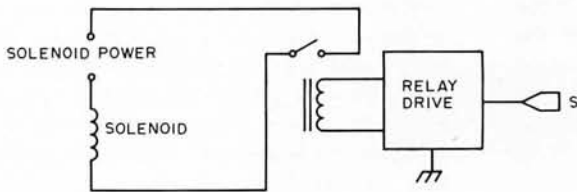
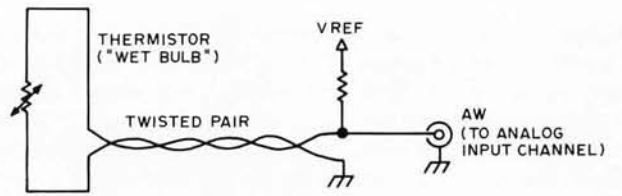
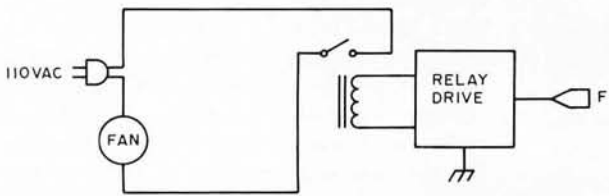
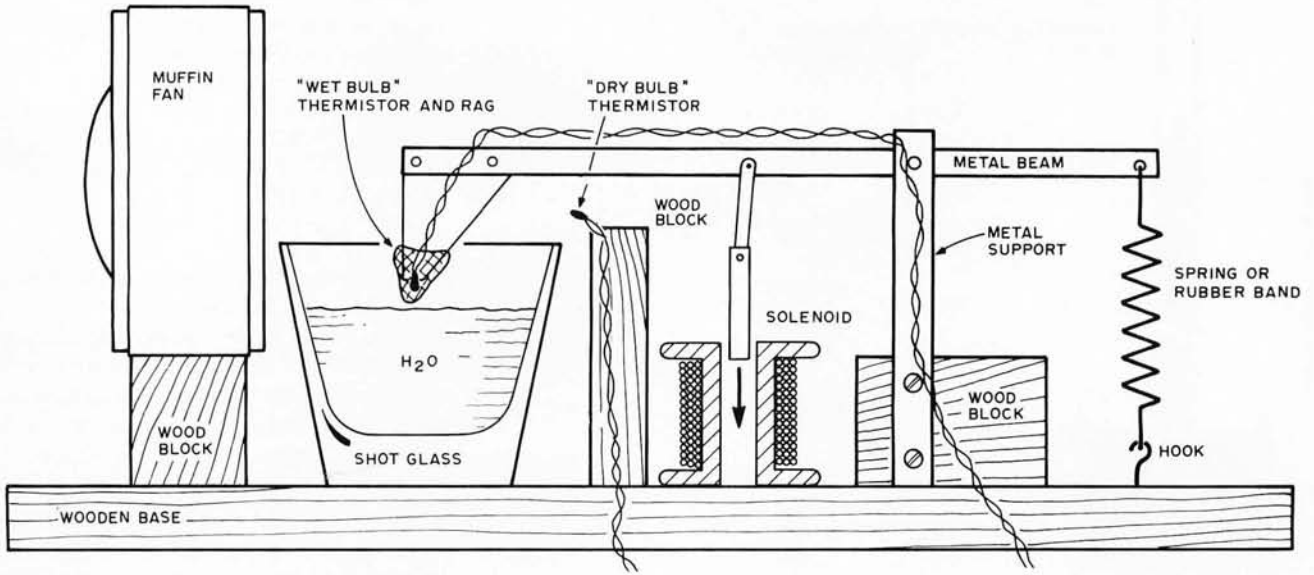

TIMING DIAGRAM

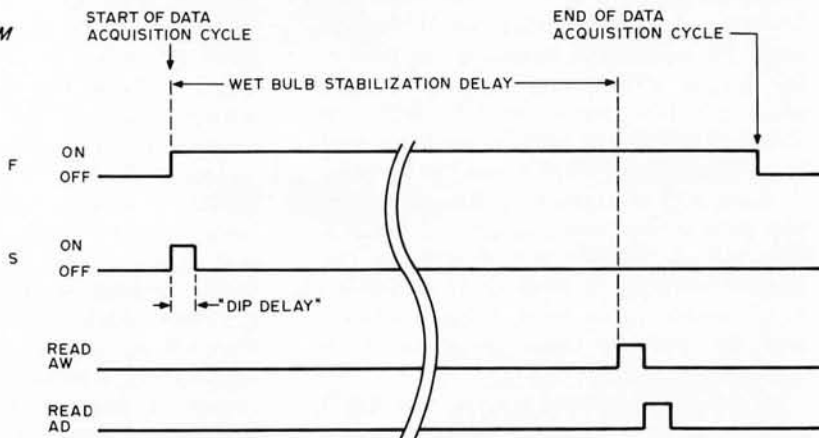

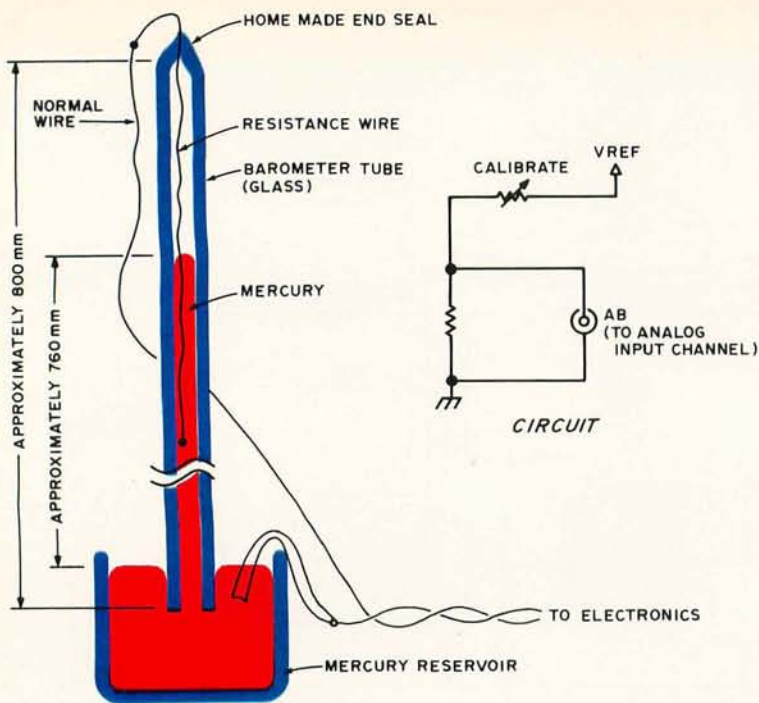

Figure 2: Conceptual Design of an Electronic Barometer. The mercury barometer can be adapted to electronic reading by using the properties of mercury and a resistance wire which is not wetted by mercury. A barometer is constructed from a long glass tube (approximately 800 mm) which is sealed at one end with a torch, after inserting about 100 to 200 mm of resistance wire. The resistance wire becomes the element of a variable resistance with the mercury of the barometer as the "wiper." A voltage across this resistance is measured by the analog to digital input channel AB and converted to a barometer reading by the software. Although exaggerated here, the residual curves in the resistance wire within the tube will lead to nonlinearities in the barometer readings. Whenever a barometer reading is to be taken, the analog to digital input channel AB is read, and the 8 bit number resulting is converted into a pressure reading for later calibration. This unit can be mounted indoors, since pressure in a house is rarely different from external pressure.

forced evaporation in a computer controlled sequence. With proper output from the computer, a single latched bit is used to drive the solenoid, a second bit to control the fan, and a time delay in the program to allow the two temperatures to settle. In theory, a specific air speed (1 meter/second) is needed, but that can be a later refinement.

Computation of the relative humidity can take several forms and you can find explanations in encyclopedias and other places. The relative humidity is close to $H = 100\% - T_c * 5$ where T_c is the difference between the wet and dry bulb temperatures in degrees Centigrade.

A potentially more accurate formula I have found is $E = E_w - 0.00066B(t - t_w) * (1 + 0.00115t_w)$; where t = dry bulb temp,

t_w = wet bulb temp, E_w = vapor pressure at t_w , B is barometric pressure, and E is the actual vapor pressure. Relative humidity is E/E_w , the actual vapor pressure over the potential maximum. Values of E may be found in reference books, or you can extrapolate from these values:

0°C,	E = 4.6
10°C,	E = 9.2
20°C,	E = 17.5
30°C,	E = 31.8
40°C,	E = 55.3

[One reference source for humidity data and formulas is the Handbook of Chemistry and Physics, 1971, Chemical Rubber Company, pages E-39 and D-148.] If you have no way of measuring the barometric pressure, using the number 740 mm will produce less than 5% error under normal conditions. (Ie: You're not in the center of a tornado or sitting on top of a mountain at 12,000 feet.)

A high relative humidity is usually needed to produce rain. Normally, unless a humid front arrives, the relative humidity is highest with the lowest temperature and falls as the temperature rises, because warm air can hold more humidity and the absolute amount of moisture remains relatively stable in a given day. A change in the pattern suggests a change in the weather. Relative humidity is rather pointless and impossible to measure by the wet bulb method at temperatures close to and below freezing.

Pressure

Speaking of barometric pressure, let's try to measure that. One way would be to take apart a dial type barometer, curve a piece of resistance wire and use the meter needle as a wiper. But I would like to offer a kind of wild alternative (which I have not tested), as seen in figure 2.

A mercury barometer consists of a glass tube about 800 mm (32 inches) long which is sealed at one end, filled with mercury and stood up with the open end submerged in a bowl of mercury. Since there is no air pressure inside the tube, the outside air pressure supports the column of mercury and we may measure the height from the surface of the bowl to the top of the column (which is why barometer readings are in inches or millimeters of mercury, even on a dial type barometer). A very low atmospheric pressure would be about 28.5 inches (724 mm) while 760 mm (29.92 inches) is standard sea level pressure. A falling barometer reading, especially a rapidly falling one, usually is taken to mean bad weather is approaching. High pressure usually suggests clearing.

Unless mercury wets the resistance wire, it should be possible to make an electronic barometer. This would be done by taking an 800 to 850 mm long glass tube of about 2 to 5 mm inside diameter and inserting about a foot of resistance wire in one end. Using a torch or Bunsen burner, the end of the tubing can be melted around the wire, sealing the end with a couple of inches of wire sticking out. With tubing this small, a quarter to one half pound (0.11 to 0.23 kg) of mercury will be sufficient to fill the tube and leave enough for the bowl. When the tubing is full (use an eyedropper), place your finger over the end, place the end in the bowl and clamp the tube gently to a support. *[Note: Both mercury and glass tubing can be had from chemical supply houses, one quarter pound being the smallest unit mercury sold. Mercury can be harmful if you breathe the vapors, swallow it or otherwise get it in your body. But there is little danger from a barometer or putting your hands in it. If you were to drop a bit, and it got into the cracks of the floor, and you worked in the unventilated room for several years (as chemists do in a lab), the vapor could become harmful.]*

Mercury is a very good conductor of electricity, hence if it wets the wire this scheme won't work. If you connect wires of a resistance measuring circuit to the bowl and the resistance wire at the top of the barometer tube, the reading will consist almost entirely of the resistance of the exposed wire above the mercury. As the mercury falls, the resistance will increase; as pressure rises, the reading will fall. The wire immersed in the mercury will not contribute to the reading.

For the most accurate readings, you will want the glass tube barely longer than the highest reading you expect. To save costly mercury, the tube diameter can be smaller than on sight barometers and will be very difficult to read by eye. However, you can calibrate it for your computer by measuring the actual height of the column or by reading resistance and using another barometer as a standard. One other caution: Do not wear jewelry when handling mercury, as it forms amalgams with silver and gold which make the gold look silverish and decrease the value of the metal.

Wind

The next weather item to measure is the wind. In most parts of the country a shift in wind direction precedes a change in weather and often the direction of the wind will directly suggest the future weather — a wind from water is cooling, from land is dry, from

HOW WELL DOES YOUR ALTAIR RUN?

Parasitic Engineering products can improve the reliability and performance of your Altair 8800 or 8800a. And, until **NEW YEARS** you can upgrade your Altair and **save \$5** at the same time.

THE IMPROVED CLOCK FIX KIT

Is your ALTAIR:

- * Slow to start up . . .
- * Writing all 0's or 1's into memory . . .
- * Producing the wrong STATUS . . .
- * Having troubles running BASIC . . .

Then your Altair may have CPU Clock problems.

Hundreds have been sold to universities, businesses, computer professionals and hobbyists. We guarantee each Clock Fix Kit to meet the Intel timing specifications for the 8080.

The improved
Clock Fix Kit . . . **only \$15**

THE C-V POWER SUPPLY KIT

Whether you have just a few boards or a full house, the **Parasitic Engineering** Power Supply Kit can deliver all the power your Altair needs. Note the performance features no simple replacement transformer can offer:

- * **HIGH OUTPUT:** 12 amps @ 8 volts:
2 amps total @ ± 16 volts.
- * **STABLE:** Output varies less than 10% for any load, and less than 5% for any input from 100 to 130 v.
- * **EASY TO INSTALL:** All necessary parts included. Installs in place of the standard Power Supply.

Don't let the Byte Snatchers get your Altair down. Guard against power line fluctuations that can rob the integrity of your computer . . .

only \$75

CHRISTMAS SPECIAL

Both kits **only \$85**

save \$5

Orders must be post-marked before Jan. 1, 1977.
All kits shipped Postpaid.
Calif. residents add 6% sales tax.

PARASITIC ENGINEERING

PO BOX 6314A

ALBANY CA 94706

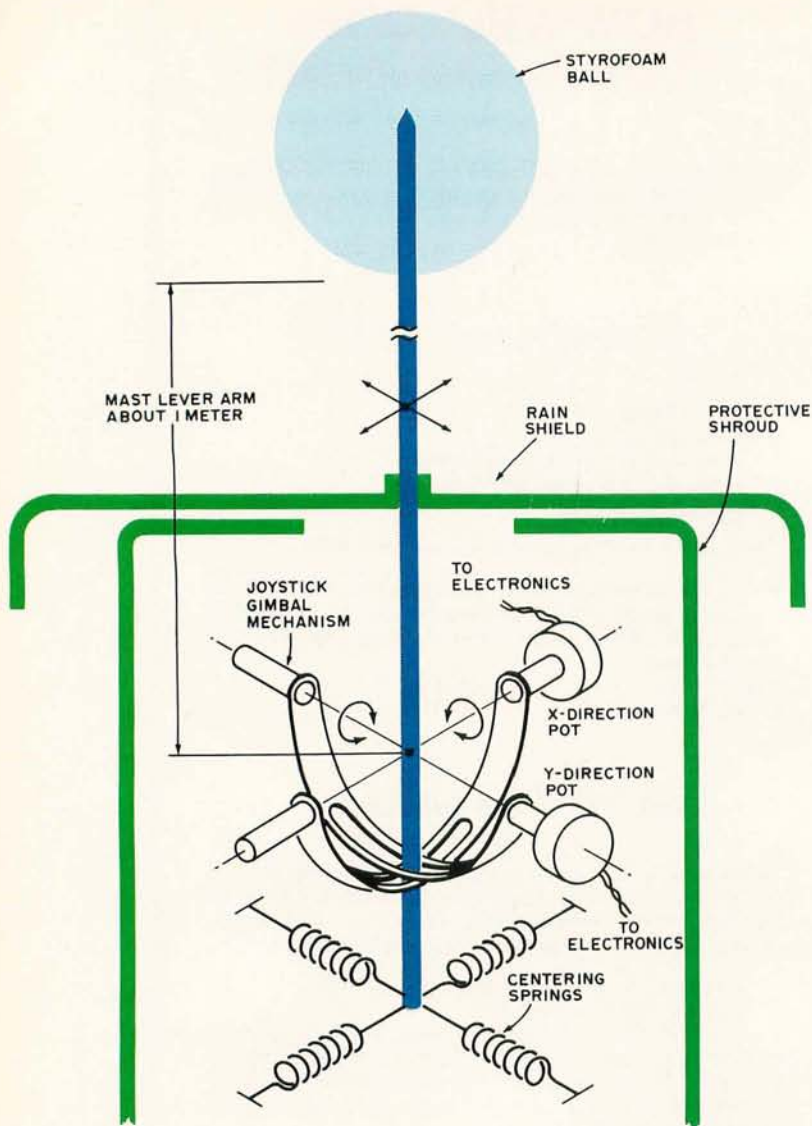

Figure 3: Conceptual Design of a Wind Velocity and Direction Measuring Instrument. A styrofoam ball is mounted on a long thin shaft (not too flexible, however). This shaft is connected to a two axis gimbal mechanism such as that provided by a joystick device. The springs are shown mounted below the gimbal for clarity, but could just as well be mounted above the gimbal point. A shroud which protects the electronics is a must, as is a mating rain shield which does not have actual contact with the shroud but does protect the opening in which the stick moves. The tension of the springs must be chosen to oppose the wind force and prevent movement of the stick to its limits of motion except in worst case (hurricane?) level winds. The wind velocity is a function of the distance off center, and the wind direction is found by the direction of the movement as measured by the resistance. Calibration can be accomplished by mounting the device on a rack on top of a car, and driving at fixed speed through a measured distance with a stopwatch for timing, on a windless day. Actual velocity can be calculated with the stopwatch and distance measures; the speedometer is merely used as a set point indicator for the test.

the south is usually warmer, from the northwest colder.

Wind is normally measured electronically by two devices: a spinning anemometer which uses optical or magnetic switches to frictionlessly create pulses, the more pulses the greater speed; and a wind vane attached to a selsyn that matches the direction to a readout. Or like the Heath Company, you can mount a circle of magnetic reed switches, with a magnet on the vane, with a closed switch or two indicating the wind direction.

But what is the point of having a computer if you don't use it? I suggest the following (untested) way to measure both the wind direction and velocity by creating a computed vector from gimbal resistance readings.

As shown in figure 3, the styrofoam ball on the long wand offers "uniform" resistance to the wind. At the base of the wand supporting the ball, a gimbal mount (like a joystick), permits us to take resistance readings which show how far from the center point the ball is. If the unit is aligned properly, we have two coordinates one the distance north or south of center (NS) and one the distance east or west (EW).

Using the formula for lengths of sides of a triangle, it is very easy to compute the distance from the center, and with a simple sine computation to get the angle. Of course, an allowance must be made (in the software) for differences in the potentiometers, etc.

The angle of the vector is the direction of the wind. After allowing for nonlinear factors such as the return springs, the way wind behaves, and flow patterns on the stick, the length of the vector is proportional to the velocity of the wind. Calibration can be done by first taking readings with no wind, for the zero point, and then at known velocities (perhaps borrowing a hand anemometer — or you could mount it on your car and take readings at different speeds as you rotated it).

Daylight

Many other additions to your weather station are possible. A set of photocells could be used to detect sunrise and sunset and possibly even gauge the overcast. The clear sky is polarized. Thus a pair of matched photocell readings in software peering through polarizing filters (like lenses from Polaroid sunglasses) which were crossed with respect to each other would give the same reading with an overcast sky and different readings with a clear sky.

Rain Volume

Measuring rain is relatively straight-

forward. A funnel collects the drops and feeds them to a tilt pan as in figure 4. As each side of the pan fills, the pan tilts, draining the full side and setting a new side. A modest counter simply counts the tilts.

The amount of rain that has fallen is given in inches. To compute it, you first measure the amount of water collected in the tilt pan for each tilt (in a graduate or measuring cup). You then compute the area of the open face of the funnel and the inches of rain per tilt is the volume of water per tilt divided by the area of the funnel. (For example, a 3 inch (7.62 cm) funnel has an area of 7.07 square inches (45.6 cm²). If eight tilts of the pan (four on each side), yielded 2 cubic inches (32.7 cm³) then the inches of rain per tilt would be 0.0354 inches (0.090 cm)).

Real Time Clock

The final item needed for dealing with the weather is the actual time. As mentioned before, this can be computed if the interrupts come at very regular intervals. However, it would be much neater to interface an actual clock with your computer. This would allow you to store specific times and dates with your data. An additional step would permit generation of interrupts at far longer intervals than the real time clocks of most computers.

The simplest actual time clock would consist of a simple TTL counter from line frequency with digit decoding (as for input to 7 segment decoding). Four inputs, two 4 bit digits to each input, would provide day, hour, minute, and seconds to be read at any time. Very simple decoding could set an interrupt, and your interrupt subroutine could check the time to see what to do (take the weather or wake you up).

A far snazzier clock might deserve an entire article to itself. It would require one input and one output port and would use a CMOS clock chip. On the same card would be decoding from 7 segment to digits and demultiplexing of the display. And since we have done that, how about throwing in a calculator chip for floating point arithmetic?

Operation of the snazzy clock would involve sending a code to the input port which would: 1) Set an interrupt latch, 2) Request a digit to be output, or 3) Load a digit to the calculator. Assuming the interrupt occurred, the computer would look at the input port and find a number representing the kind of interrupt, which it could then use for a subroutine jump. To get the time (or a calculated digit), the computer would send the appropriate code with the digit number to the output port. The display

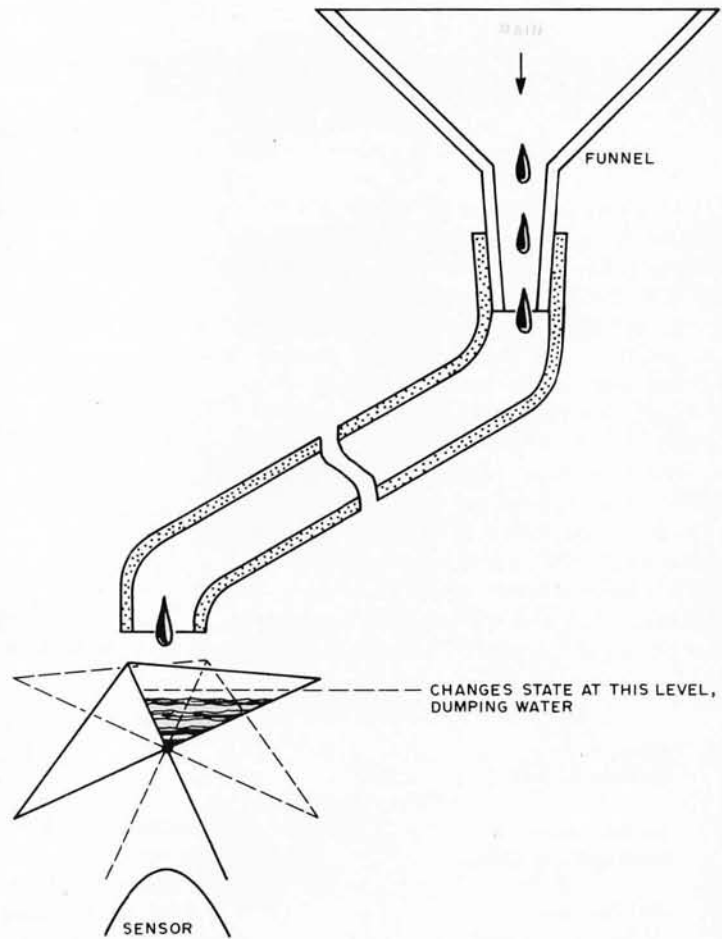

Figure 4: Conceptual Design of an Automatic Rain Gauge. The rain is collected by a funnel of known area, and piped down to the metering setup. The metering is accomplished with a "tilt pan." When the pan fills up to a level which depends upon its design, it flips over into a second state, dumping the previous water and causing a lever arm to pass the sensor. The amount of water needed to reach the tilt point is a known volume. By counting sensor output pulses during a rain storm, the total volume is measured. Given the area of the funnel, the weather data acquisition program can calculate the "inches of rain" from the volume count. The sensor might be a magnet and a reed switch, or a photocell and an LED source. (It is even conceivable that the sensor could be a microswitch with a feeler arm.)

would be demultiplexed and the appropriate number would be latched to the input. Stepping through the digits would get the whole number.

But enough of that. Predicting the weather can be a fascinating challenge, perhaps the ultimate game, in which the prize is being right (or dry). You can begin simply and build to any level you wish. ■

About the Cover

This month's cover is by Victor Ivashin, engineering project manager, Transamerica Computer Co, 2470 Estand Way, Pleasant Hill CA 94523. He is one of ten—yes, ten—grand prize winners of BYTE's first (but probably not last) computer art contest. We were pleasantly overwhelmed with so much excellent art that our original modest list of prizes (one grand prize winner, two runners up, five honorable mention winners) had to be revised upward.

Each of the following talented entrants will receive \$100, lifetime subscriptions to BYTE, bound volumes of BYTE Volume 1 (numbers 1-16), and will see his or her work on the cover of a future BYTE:

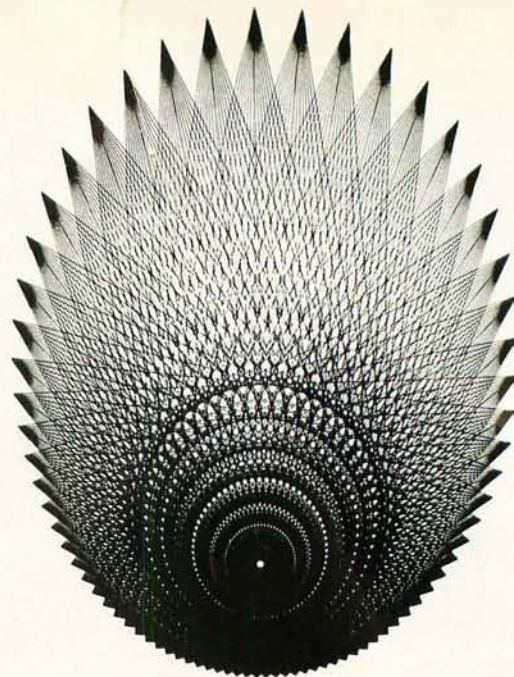

...and the Contest

Duane Bibby
Mt View CA 94040

Sandra Crandall
Naragansett RI 02882

Walt Donovan
University of Illinois
Urbana IL 61801

Larry Jubb
Melanie Jubb
San Jose CA 95112

Scott Juds
Lynnwood WA 98036

Henry Lieberman
Steve Phillips
Ken Kahn
Aubrey Jaffer
Bonnie Dalzell
Cambridge MA 02139

Birgit Quednau
Giessen, GERMANY

Dave Sheppard
Viroqua WI 54665

Arthur C Taber
San Francisco CA 94127

Runners up will receive one year BYTE subscriptions, see their art appear through the months on the inside pages of BYTE and be paid at our usual rates according to the size and number of their illustrations used. They include:

Ken Aupperle
Melville NY 11746

David Caulkins
Los Altos CA 94022

Margot Critchfield
Pittsburgh PA 15260 (see page 139)

Keith Paul Ewanco
Pittsburgh PA 15204

Anthony Harper
Garden City AL 35070

Gary Hill
Woodstock NY 12498

B Lynn Irwin
Longmont CO 80501

Joseph P Jacobson
Maple Shade NJ 08052
Christian Kuebler
Trevose PA 19047 (see page 6)

Michael Mozer
Berkeley CA 94707

Mike O'Shaughnessy
Durham NH 03824

Stephen J Rogowski
Cohoes NY 12047 (this page)

James Templeman
Springfield VA 22152

Tedd Wolf
New York NY 10034 ■

Introducing Sol Systems

**A complete computer/terminal
concept with all the
standard features, software
and peripheral gear you
want in your
personal computer.**



Sol Systems put it all together. One source for hardware and software. One source for engineered compatibility of computer and peripherals. That's the Sol plan.

Though the microprocessor made the powerful small computer possible, a lot of folks found out early efforts in the marketplace were selling the sizzle a lot more than the steak. After an initial investment of several hundred dollars, you ended up with some nice parts, but no memory of any kind, no I/O devices or interfaces, no display, print-out or software.

The Sol plan ends all that. Processor Technology takes the position that it's far better to be right than first. So let's get down to the Sol no tricks plan.

For \$995 in kit form, the first complete small computer

Standard is a basic word at Processor Technology. The Sol-20 has more standard features than any other small computer we know of. Here's what you get.

8080 microprocessor* 1024 character video display circuitry* 1024 words of static low-power RAM* 1024 words of preprogrammed PROM* a custom, almost sensual 85-key solid-state keyboard* audio cassette interface capable of controlling two recorders at 1200 baud* both parallel and serial standardized interface connectors* a complete power supply* a beautiful case with solid walnut sides* software which includes a preprogrammed Prom personality module and a cassette with Basic-5 language plus two sophisticated computer video games* the ability to work with all S-100 bus (Altair 8800/IMSAI/PTC) products.

There are no surprises. Everything you need to make it work is here. In kit form, nominal assembly time from our fully documented instructions is four to seven evenings.

Or start with the Sol-PC for just \$475

You can begin your Sol system with the all on one board Sol-PC kit. It has all the

memory and interface electronics including video display, keyboard interface, audio cassette interface, all necessary software and the ability to accept the full Processor Technology line of memory and interface modules. Use the Sol-PC as the basis of a microcomputer, low cost CRT terminal or editing terminal

And these specs are standard

Display: 16 lines of 64 characters per line. Character set: 96 printable ASCII upper and lower case characters plus 32 selectable control characters.

Display position: Continuously adjustable horizontally and vertically.

Cursor: Selectable blinking. Solid video inversion. Programmable positioning standard.

Serial interface: RS-232 and 20-mA current loop, 75 to 9600 baud, asynchronous.

Parallel interface: Eight data bits for input and output; output bus is tristate for bidirectional interfaces; levels are standard TTL.

Keyboard interface: Seven-level ASCII encoded, TTL levels.

Microprocessor: 8080, 8080A, or 9080A.

On-card memory: 1024 bytes PROM (expandable to 2048 bytes), 2048 bytes RAM.

External Memory: Expandable to 65,536 bytes total ROM, PROM, and RAM.

Video signal output: 1.0 to 2.5 volts peak-to-peak. Nominal bandwidth is 7 MHz.

Power required ($\pm 5\%$): +5 volts at 2.5 amperes, +12 volts at 150 mA, and -12 volts at 200 mA.

The Sol plan, completely expandable.

By filling the basic main frame with tailor made Processor Technology plug-in PC boards, you can really expand the computing power and flexibility of your Sol-20 Personal Computer.

New items are being announced frequently, but right now, here are some of the

things you can add to your Sol-20. The ALS-8 Firmware module is an assembly language operating system to give you the power to develop and run programs. Use it to quickly write, edit, assemble, de-bug and run your own programs. Some say it's the most useful software development on the market today, but modesty prohibits.

And when it comes to add-on memory boards, you've come to the right place. We've probably got more than anyone else. Choose from 2K ROM or 4, 8 or 16K RAM (read all about the 16KRA board on the last page of this ad). The PT 2KRO will accept up to eight 1702A or 5203Q erasable, reprogrammable memories (EPROM's) with the ability to store in a non-volatile fashion up to 2048 eight-bit words.

Our read/write memories are the industry standards for high reliability. We know, because we have literally scores of customer letters saying "Your memory modules work and keep on working."

To help you solve additional interfacing problems, add the 3P+S I/O module. Here's a board with two 8-bit parallel I/O ports with full handshaking logic and a serial data rate that can be set anywhere between 35 and 9600 baud. Set up control conditions for both parallel and serial ports. Data and error flags can be polled.

A full line of Sol-20 tailored peripherals

No computer can do the full job without the right set of peripheral gear. PT has sought out the best manufacturers of peripheral equipment and worked with them to give you a choice of quality so you can get the most out of your Sol-20. Choose from line and serial printers, perforated tape readers and punches, floppy disk memories, black and white or color graphics displays, A/D, D/A converters and more.

Software, the Computer Power Essential

A big part of making the first complete small computer is providing you with a wide range of easy to use, easy to obtain, low cost software. For the Sol-20, we've developed a whole group of offerings. And more are on their way.

TREK 80

Based on the NBC television series STARTREK, this 8K assembly language program uses the VDM graphics capability for real time war with the Klingons. No holds

barred, they're out to get you from each of the 100 quadrants. TREK 80 resides and runs in 8K of memory and requires the PTC Sol or VDM-1.

New PT 8K Basic

Processor Technology has the fast new BASIC you've needed for so long. Using our superior BCD math, the speed of the new language is double that of our own fast BASIC-5. To multiple program capability, we've added strings, multidimensional arrays and multi-line, multi-variable, user functions. This is the BASIC for full capability systems. Look at the BUSINESS ANALYSIS program example in the manual to find out how PT 8K BASIC gives you more while using less memory for the working program.

Five reasons why it's so good

1. Strings are not limited to a length of 256 characters and can extend to the bounds of memory.
2. Renumbering of lines with full gosub, etc. updating. Also EXAM and FILL allow for direct memory operations while IN and OUT provide direct I/O capability.
3. Every statement is fully implemented. RESTORE, for instance, restores the data pointer as usual. BUT, with PT 8K BASIC, RESTORE 100 will set the pointer to the data located at line 100.
4. Fully implemented string and math functions include all of the standards — VAL, STR, ASC . . . EXP and LOGI and LOG. Also, the more advanced statements such as ON-GOTO and IF THEN ELSE along with a loop EXIT are provided.
5. PT 8K BASIC has a 'perfect' implementation of PRINT USING which saves program memory space while still providing more capability than the usual PRINT USING.

The new PT 8K BASIC is similar to the version we're developing for ROM. You use it here before buying the more expensive ROM.

You'll find your PT 8K BASIC also includes both a built-in VDM driver and special editor. The cassette version also includes named program SAVE and LOAD for the CUTS Cassette interface or Sol.

New 8080 FOCAL™ DEC

8080 FOCAL has been updated to include operator precedence and all other standard FOCAL conventions. It also has a driver for VDM-1 display and PT Cassette program SAVE and LOAD This version is available only on CUTS Cassette and resides in 8K of memory.

GAMEPAC 1 to entertain family and friends

Show off your VDM-1 and computer with this lineup of video games. Each is included on the cassette or paper tape.

TARGET keeps track of your hits and misses while you blast away at the moving target. You and your family can get together for whole evenings at a time with this one.

ZING. Learn hexadecimal arithmetic fast with this VDM game as two players keep the five balls in the air. If both of you get too good... ZING, of course, will make it harder.

LIFE. The Sol or VDM makes a good display for the game of life and this version allows two modes of operation. The universe can be flat or wrapped around on itself. The real meaning of life we'll leave to you but it's fun to watch.

PATTERN. We haven't figured this one out ourselves but it's sure nice to have your computer doing it. You choose the geometric design and how rapidly it changes.

Sol Systems Price List

(prices are net, effective Dec. 1, 1976)

SOFTWARE

ITEM with manual	Source	CUTS cassette	Paper tape
BASIC 5 software #2	yes	**	\$19.50
8K BASIC	no	\$29.00	\$37.00
New 8080 Focal	no	\$14.50	N/A
TREK 80 video game	no	\$ 9.50	\$14.50
GAMEPAC 1 video games	no	\$ 9.50	\$14.50
MATHPACK video calculator	yes	\$14.50	\$19.50
ASSEMBLER software #1	yes	\$14.50	\$19.50

**CUTS cassette of BASIC 5 is included FREE with all orders for Sol units or CUTS cassette interfaces. Additional cassettes available for \$14.50.

Sol system owners be sure to note Sol system on your order. These special versions use less code and provide easier loading along with more convenient operation. SOLOS, SOLED and CONSOL all have provision for the special versions.

All Processor Technology software is distributed on an individual sale basis for personal use. No license to copy, duplicate or sell is granted with this sale. Each software package has been copyrighted by Processor Technology and all rights therein are reserved.

Sol Terminal Computers

Kit Price

SOL-PC SINGLE BOARD TERMINAL COMPUTER™ **\$475.***

SOL-10 TERMINAL COMPUTER™
Sol-PC with case, power supply and 70 key solid state keyboard. **\$795.***

SOL-20 TERMINAL COMPUTER™
all features of Sol-10 with larger power supply, 85 key solid state keyboard, fan, and five slot expansion backplane. **\$995.***

*Sol prices include CONSOL Personality Module. If SOLED Intelligent Editing Terminal Module or SOLOS Stand-alone Operating System Module is desired instead, add \$100. If ordered separately, personality modules are \$150 each.

Memory Modules

Kit Asmbld.

ALS-8 PROM Resident Assembly Language Operating System — **\$425**

SIM-1 Interpretive Simulator add-on option for ALS-8 — **\$ 95**

TXT-2 Text Editing add-on option for ALS-8 — **\$ 95**

2KRO Erasable PROM module **\$ 65 \$ 89**

4KRA 4096-word Low Power Static RAM **\$159 \$195**

8KRA 8192-word Low Power Static RAM **\$295 \$375**

16KRA 16384-word Dynamic RAM — **\$529**

Interface modules

3P+S Parallel, Serial I/O module **\$149 \$199**

CUTS Computer Users Tape System cassette interface **\$ 87 \$119**

VDM-1 Video Display Module **\$199 \$295**

Mass Storage Systems

Helios II Disk System™
includes dual PerSci 270 floppy disk drive, cabinet, fan, S-100 bus compatible controller, power supply, system diskette with complete PTDOS software **\$1895 \$2295**

Misc.

EXB Extender Board **\$ 35 \$ 45**

WWB Wire Wrap Board **\$ 40 —**

Prices, specifications and delivery subject to change without notice. Please allow up to two weeks for clearance of personal checks. Mastercharge accepted. All orders amounting to less than \$30 must include \$3 for handling.



New 16K RAM, fully assembled, \$529

More bits per buck than ever before on a fully burned in and tested board unconditionally guaranteed for one year.

Processor Technology made the first 4K static RAM modules for the home computer market. Now in a price performance breakthrough we offer you a 16,384 byte dynamic memory module assembled, tested and burned in. Not a kit—and at \$529 who'd want to build it from scratch?

Processor Technology gives you the features to make 4K dynamic RAMS work for you.

- Invisible refresh, no waiting while CPU is running.
- High speed 400 μ sec access time worst case Z-80 and 8080 compatible.

- Versatile addressing, each 4096 byte segment is individually addressed to any of the sixteen available 4K segments.
- Low power—typically 5 watts when running—the same as most 4K memory modules.
- BATTERY BACKUP capability built-in for standby operation.
- IMPORTANT NOTICE—No 16K memory module available is fully, truly static. 4200/4402 type "static" RAM's have high level, high current clocks with high transient power levels. Any RAM with 12 volt 30 mA clock pulses should not be called "STATIC" just because each memory cell is a flip-flop.

Specifications

Access Time	400 nsec max
Cycle Time	500 nsec max
Rams Used	Intel 2104 or Mostek 4096 types
Capacity	16384 8-bit bytes
Memory Protect	standard on card
Addressing	each 4096 byte page addressable
Operating Power	+7.5 to 10 VDC at 0.4 A typical +15 to +18 V at 10 mA typical -15 to -18 VDC at 20 mA max

The new Processor Technology 16K board is available for immediate delivery. See your nearest dealer listed below or contact us directly. Address Processor Technology, 6200 Hollis Street, Emeryville CA 94608, Phone 415/652-8080.

Processor Technology Dealers

CALIFORNIA

The Byte Shop
1514 University Ave.
Berkeley CA 94703

The Byte Shop
2559 South Bascom Ave.
Campbell CA 95008

The Computer Mart
624 West Katella #10
Orange CA 92667

The Byte Shop
2227 El Camino Real
Palo Alto CA 94306

The Computer Center
8205 Ronson Road
San Diego CA 92111

The Computer Store
of San Francisco
1093 Mission Street
San Francisco CA 94103

FLORIDA

The Byte Shop
509 Francisco Blvd.
San Rafael CA 94901

The Byte Shop
3400 El Camino Real
Santa Clara CA 95051

The Byte Shop
2989 North Main St.
Walnut Creek CA 94596

Microcomputer
Systems Inc.
144 So. Dale Mabry Hy.
Tampa FL 33609

Atlanta Computer Mart
5091-B Buford Hwy.
Atlanta GA 30340

GEORGIA

ILLINOIS

The Numbers Racket
518 East Green Street
Champaign IL 61820

itty bitty
machine co., inc.
1316 Chicago Ave.
Evanston IL 60201

The Chicago
Computer Store
517 Talcott Road
Park Ridge IL 60068

The Data Domain
111 South College Ave.
Bloomington IN 47401

The Computer Store
of Ann Arbor
310 East Washington
Ann Arbor MI 48104

MICHIGAN

NEW JERSEY

The Computer Mart
of New Jersey
151 Kline Boulevard
Colonia NJ 07067

Hoboken Computer Works
56 Second Street
Hoboken NJ 07030

Audio Design Electronics
487 Broadway, Ste. 512
New York NY 10013

The Computer Corner
200 Hamilton Ave.
White Plains NY 10601

The Computer Mart
of Long Island
2072 Front Street
East Meadow, L.I. NY 11554

NEW YORK

OREGON

The Computer Mart
of New York
314 Fifth Ave.
New York NY 10001

Synchro Sound Enterprises
193-25 Jamaica Ave.
Hollis NY 11423

The Real Oregon
Computer Co.
205 West 10th Ave
Eugene OR 97401

Computer Power, Inc.
M24 Airport Mall
1800 Post Road
Warwick RI 02886

TEXAS

The Micro Store
634 South Central
Expressway
Richardson TX 75080

WASHINGTON

The Retail Computer Store
410 N.E. 72nd
Seattle WA 98115

WISCONSIN

The Milwaukee Computer Store
6919 W. North Ave.
Milwaukee WI 53213

CANADA

The Computer Place
186 Queen St. West
Toronto, Ontario M5V 1Z1

Trintronics
160 Elgin St.
Ottawa, Ontario



**Processor
Technology**
Corporation

Signal Processing for Optical Bar Code Scanning

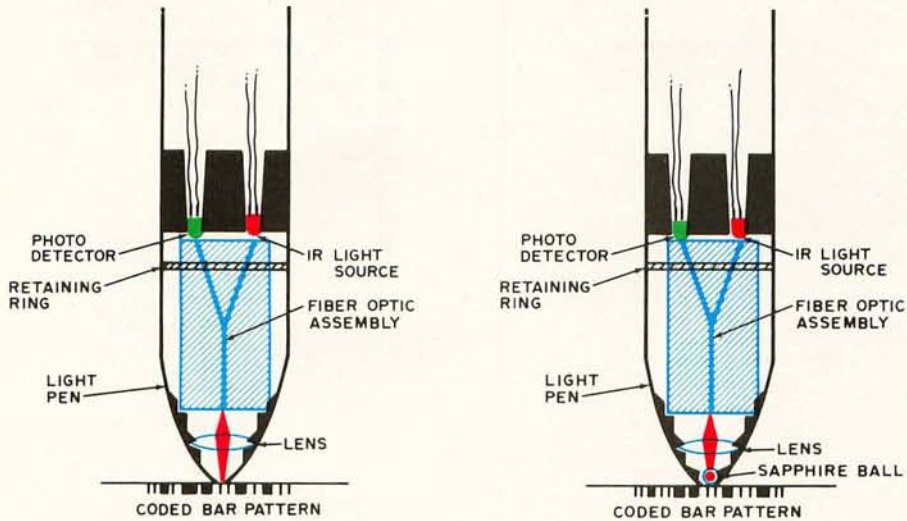

Figure 1: Typical Commercial Fiber Optic Head Assemblies. The left diagram has a simple head; the right diagram shows a transparent sapphire ball used as a rolling contact point. In either case, light from the infrared source enters one set of fibers, passes to the end of the fiber assembly, through the lens(es) to the paper, is reflected or absorbed depending on color, returns through the lenses, and finally passes back up the other set of fibers to the photo detector. A disadvantage of this particular configuration is that the vertical incidence of light and reflected images can cause specular reflection problems.

Frederick L Merkwowitz
134 N Main
Natick MA 01760

To input bar coded data into your system it is necessary to convert the printed variable width bars into logic level signals suitable for serial data entry. To convert the serial bit stream into parallel, byte organized data, pattern recognition techniques are necessary. This article outlines the basics of the hardware aspects of bar code scanning covering various optical systems, detector characteristics, and signal conditioning. The software aspects are covered in another article in this issue of BYTE.

Optical Systems

There are two prime optical techniques for imaging the coded bar pattern onto the active region of the photodetector. The first and most widely used in commercial products are fiber optic bundles such as illustrated in figure 1. With this method, energy from a light source (either an infrared or red light emitting diode or an incandescent bulb) is focused onto the polished end of one of two plastic or glass optical fiber bundles while the photodetector receives the reflected light energy from the polished end of the other bundle. The two bundles are randomly merged and formed into a Y shaped assembly. At the bottom of the Y, light emerges from the polished end, is focused through a lens either onto a clear or

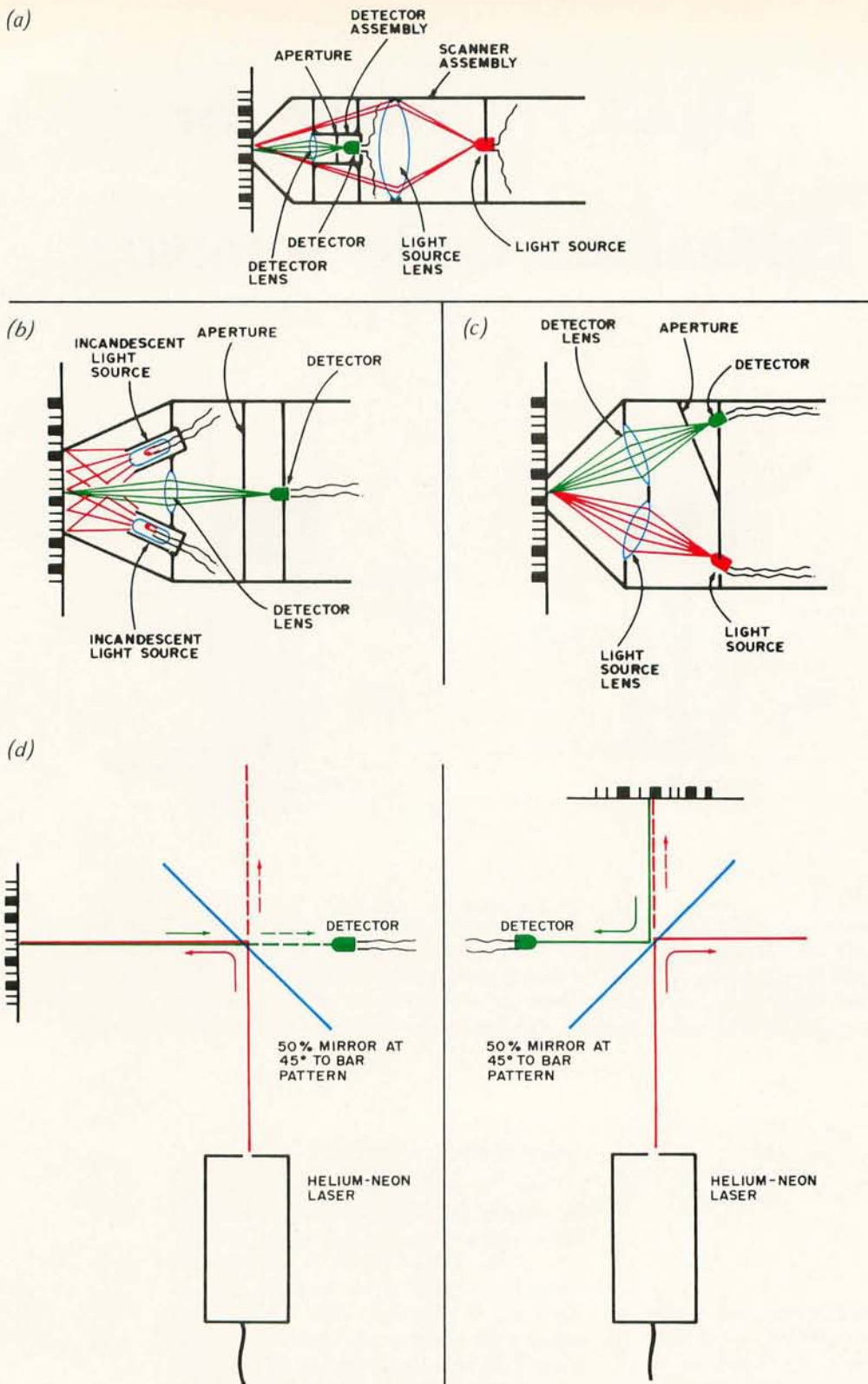

Figure 2: Some Alternate Physical Configurations of Optical Heads. (a) Coaxial optics uses a detector and its source mounted coaxially with separate lenses. As in all vertical viewing systems, specular reflection is a potential problem. (b) Side by side optics uses a separate source and detector lens, with an oblique angle which lessens specular reflection problems. (c) The floodlight approach eliminates lenses for the source, and floods the bar pattern with more light than it needs. (d) Laser fixed beam scanners dispense with lenses at a price: the much higher cost of the laser. At the left, the target is at right angles to the beam; at the right, the target is in line with the beam.

HAVE A MERLIN CHRISTMAS!!!

If your favorite computerist has an 8080 bus system, what better way to say Merry Christmas than with a MERLIN Video Interface? MERLIN is not just a superb character display . . .

MERLIN is a whole system . . .

MERLIN is a text display,
a high density graphics display,
a keyboard interface,
a serial I/O port,
a RAM/ROM memory and,
an intergrated and expandable
software package.

MERLIN is a gift that keeps giving. MERLIN's keyboard and I/O connector allows the MERLIN owner to add a variety of Miniterm hardware expansion products. MERLIN's ROM software will turn your computer system into a professional software development tool. Give your favorite computerist (yourself, perhaps?) a MERLIN for Christmas.

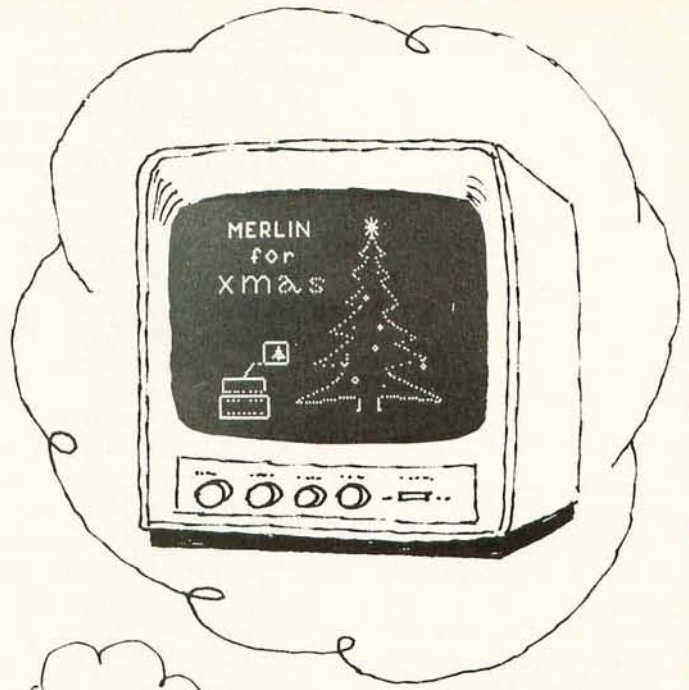

THE INTELLIGENT VIDEO INTERFACE

ROM Monitor/Editor software makes your computer into a professional software development system. User Manual contains full listing.

Altair/IMSAI Plug-in Compatible.

Graphics: 160H or 80H by 100V.

ASCII: 40 characters by 20 lines.

Programmable Display Format.

Also coming are MERLIN add-ons: 1500 baud cassette unit, game controller, super dense graphics, joystick interface, and more interface boards such as Modem and cassette with ROM software.



An assembled, tested MERLIN is *only* \$349; in kit form, which includes PC boards, IC sockets, User Manual and all parts except memory MERLIN is *only* \$249. The Monitor/Editor (MBI) ROM, 2K X 8, plus 256 X 8 RAM which plugs into MERLIN is \$39.95. A User Manual is available separately and deductible from your MERLIN order, for \$8.00. Master Charge and BankAmericard accepted. For phone orders and delivery schedule call (617) 648-1200.

All prices subject to change without notice.



MiniTerm Associates, inc.

Box 268, Bedford, Mass. 01730

red colored sapphire ball and thereby onto the printed bar pattern or directly onto the bar pattern. Light reflected from the bar pattern returns through the ball and lens or lens and is refocused onto the optical fiber bundle. One half of the light travels back through the detector bundle to the detector.

Figure 2 illustrates the other more direct methods of imaging the bar pattern onto the photodetector. In figure 2a light is focused through the larger lens onto the bar pattern, reflected through the small lens and then onto the photodetector. This method, called coaxial optics, is used in another commercial scanning system.

Figure 2b illustrates a side by side approach where the light from the source and the light reflected from the bar pattern pass through identical lenses.

In figure 2c the source floods the viewing area of the bar pattern with light, thereby saving the cost of one lens. While there is a lens used for focusing the reflected light onto the photodetector, the total energy incident on the detector is quite low and therefore more gain is needed in the signal conditioning circuitry.

Figure 2d illustrates a novel use for your hobby laser (such as those purchased from

Edmund Scientific). This is called a fixed beam laser scanner (to distinguish it from a scanning beam reader) and will operate with lasers of 0.5 mW (500 microwatts) power output or less. In this system the laser either shines through a beam splitter (50% mirror) or is reflected from the mirror onto the bar pattern and reflected directly back to the mirror where it either is reflected from the mirror or passes through the mirror onto the photodetector. The advantage of this system is that because the laser beam spot size is approximately 10 mils (0.01 inch, 0.0025 cm) at the half power points, no lenses are needed for focusing either the incident or reflected light.

With all of the systems described, there is always the choice of either moving the light source and detector past the coded bar pattern or fixing the source and detector assembly while moving the bar pattern past the beam of light.

Detector Characteristics

Light reflected from the coded bar pattern (10 nW to 1 mW) impinges on a silicon photodetector, either a photo transistor or a photo diode. While the photo transistor, either in a single or Darlington transistor configuration, inherently offers far more detector gain, there are tradeoffs in speed (10 to 100 μ s rise and fall time for the photo Darlington, 1 to 10 μ s rise and fall time for the photo transistor) signal linearity, and dark current. The photo diode or photo PIN diode offers the highest speed (10 to 100 ns rise and fall time for a photo diode, 1 to 10 ns rise and fall time for the PIN photo diode), linearity (7 decades of range for the PIN photo diode) and lowest dark current (1 to 10 nA for the PIN photo diode).

While the light may originate from an incandescent, red or infrared LED or helium-neon laser, the spectral characteristics of the silicon detector, whatever its configuration, is such that approximately 80% of its response to energy occurs in the near infrared wavelengths of 0.75 to 0.9 microns (see the *GE Optoelectronics Handbook*, 1976 edition); therefore, an efficient electro-optical system will have a source with the majority of its emitted energy in the same band.

Signal Conditioning

After the photodetector converts light photons into electron-hole pairs, the signal conditioning circuitry amplifies the faint signal (10 nA to 1 mA peak to peak, 100 μ V to 100 mV peak to peak) to a useful level, in most cases logic level (1.6 mA, 5 V).

There are a number of elements to the "standard" signal conditioner, as illustrated

About the Author

Fred Merkwitz has considerable experience with bar code electronics as it is commercially practiced, through employment over the years with Electronics Corporation of America, RCA and Identicon. Like a number of people in this field, electronics is both his hobby and profession.

BABY! I MICROCOMPUTER

Not a kit:



Burned in:

- Portable; supplied in attache case:
- Tape interface; 1200 baud:
- Video output; 128 character flicker free:
- Modular expansion:
- Software supplied with system:

BABY! I SYSTEM with 2K RAM	\$850.00
BABY! I SYSTEM with 4K RAM	\$1000.00
4K Static RAM Add-In	\$205.00
STUNT CARD FOR SYSTEM Expansion:	\$250.00
2 P.I.A.'s Tri-State Buffered Data, and Address.	
Interrupts and I/O Serial TTY with 50 Pin Connector.	
"BABY! I" Floppy Diskette Drive:	\$750.00
with Power Supply and Controller.	

- Warranty and maintenance program:

STM SYSTEMS, INC.
 P.O. BOX 248
 MONT VERNON, N.H. 03057
 603-673-2581



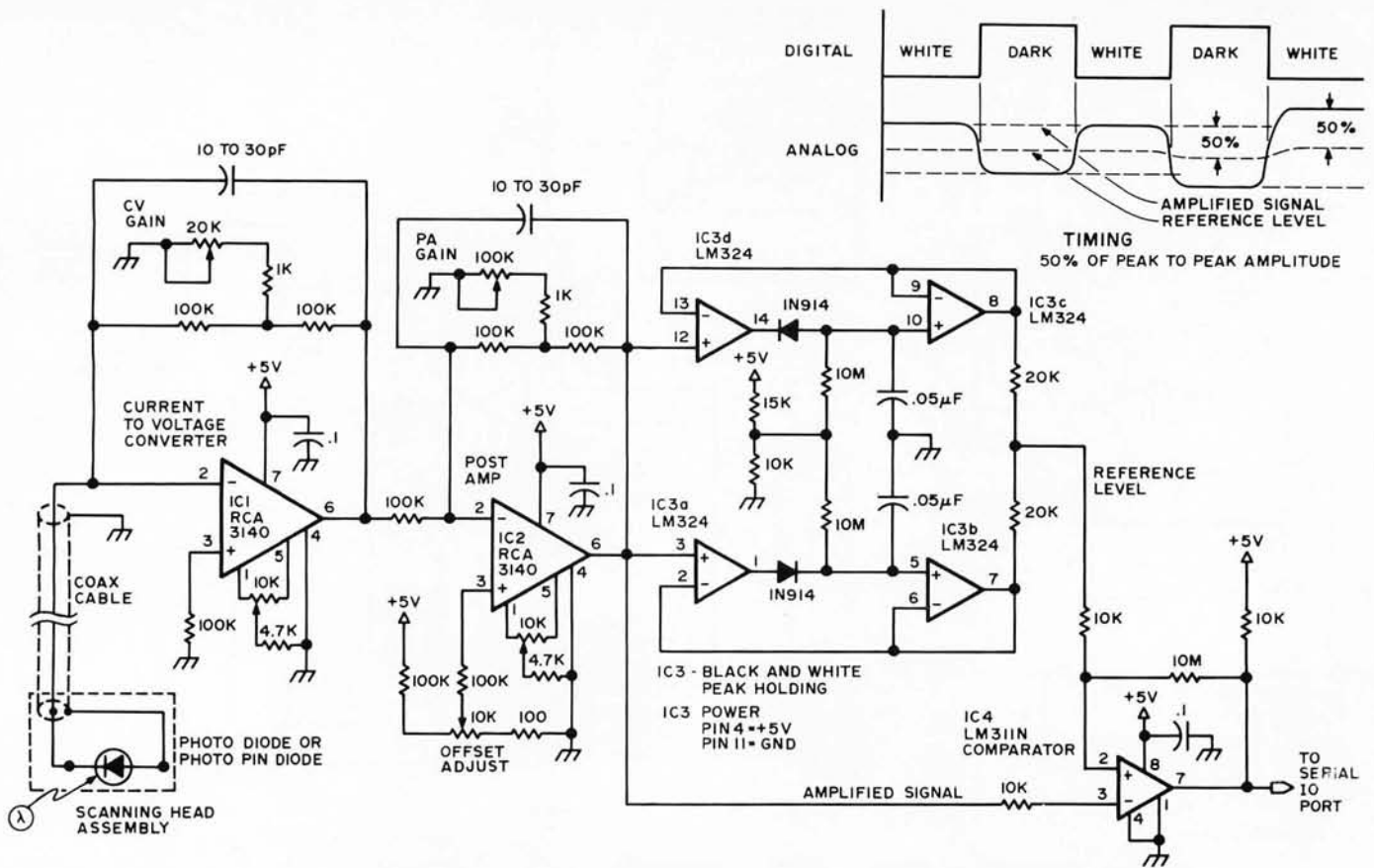

in figure 3: The current to voltage converter (assuming you are using a photo diode for speed and linearity), a post amplifier, a black and white level peak holding circuit and finally a comparator that acts as a 1 bit analog to digital converter.

The current to voltage converter illustrated is a bit unconventional in that the volts per microampere conversion factor is adjustable from $10 \text{ V}/\mu\text{A}$ down to $0.5 \text{ V}/\mu\text{A}$ with the component values shown. The post amplifier is again adjustable with a gain factor of 1 to 100. The peak holding circuit holds the peak values of the white level and the black level for the length of time necessary to read through a line of coded bar pattern. The difference between these peak values is divided in half. This 50% peak to peak voltage is presented to the reference input of the comparator while the amplified signal level is presented to the inverting input. If the signal level is greater than the reference level (implying a white space), a 0 logic level is output from the comparator; and if the signal level is less than the reference level (implying a black bar), a 1 logic level is output.

Another, possibly superior, experimental signal conditioning circuit is shown in figure 4a. It combines a "super differentiator" for

Figure 3: A "Standard" Signal Conditioning Circuit. This circuit processes the low level signal from a photo diode, converting its current output to a voltage in the first amplifier, amplifying it further with a second stage. The amplified signal is then routed to peak holding circuits which set the reference level and a comparator which outputs a 0 or 1 level based on the reference level established.

edge detection, a high gain AC amplifier, and a dual window comparator. In the "super differentiator" the DC current level at the base of the photo transistor (Q1) is maintained at a constant level by DC servo action whether the change in DC level is caused by temperature variations, ambient light, fiberoptic cable crosstalk, varying gray level of pattern background or any other DC or low frequency factor. Q1 may also be any NPN high speed transistor with the electro-optical input through a photo diode, as shown in figure 4b, for maximum bandwidth.

The amplified differentiated electro-optical signal is picked off at the collector of Q2 where it is further AC amplified and passed to a dual threshold comparator. The output of the comparator is a short pulse at each transition of the space to bar and bar to space edge. These pulses can either tickle the interrupt input of your microcomputer or when fed to a flip flop (toggle) they can be

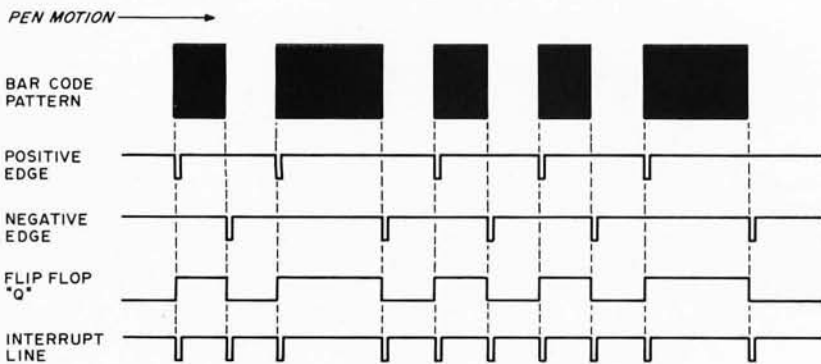
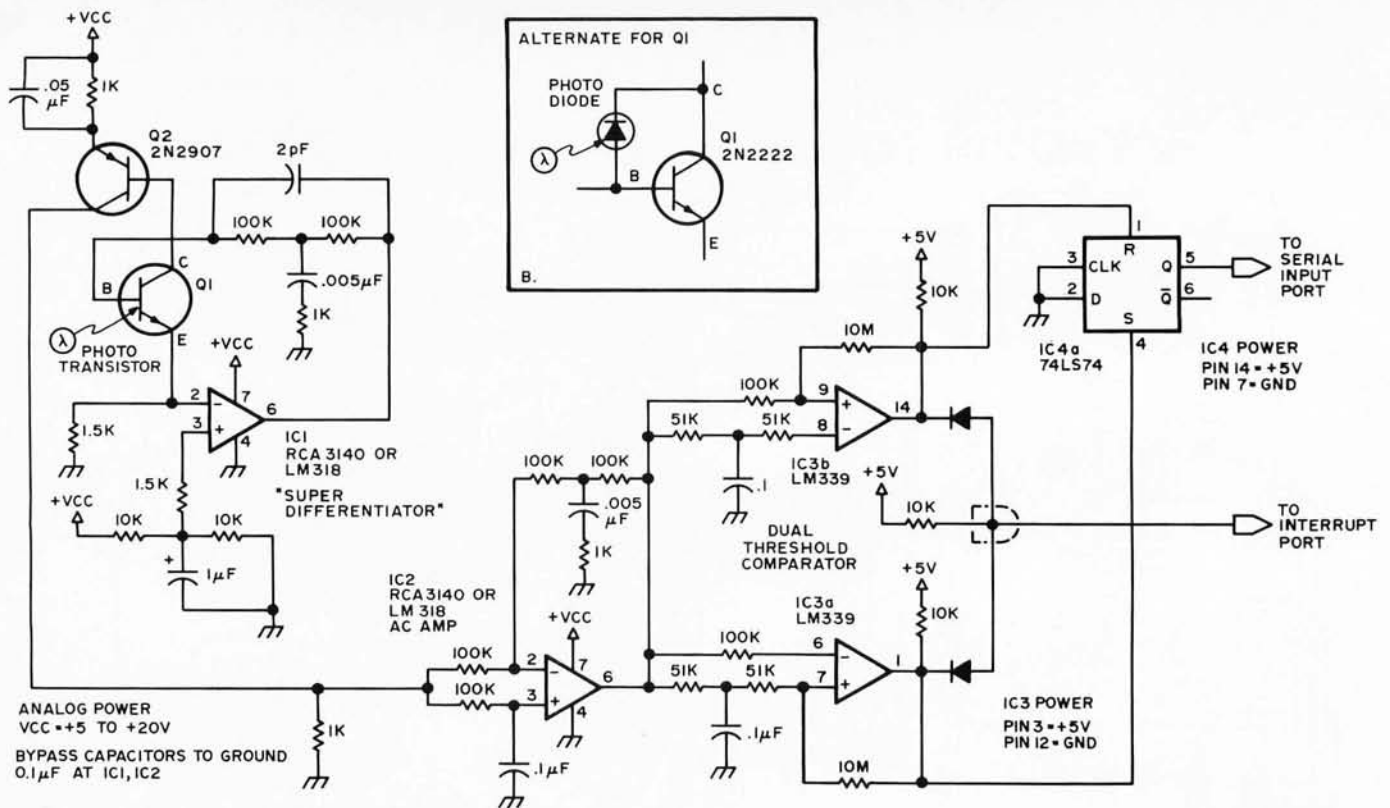

Figure 4: A "Super Differentiator" Signal Conditioning Circuit. This circuit is edge sensitive and outputs short pulses at each black to white or white to black transition. The timing diagram shows the outputs of the circuit, corresponding to the bar code pattern shown.

Software Structure For Interrupt Driven Scanning:

COUNT LOOP: A background program with a tight loop which increments a counter until an interrupt occurs. The counter is reset by interrupt service.

INTERRUPT SERVICE: Response to the interrupt which stores away the count, clears the count, then resumes the COUNT LOOP. Initialization of the scan follows the first low (ie: approximately correct) count. The first black bar width should go into the first address of the input table, with alternating pairs of black then white counts filling the input table until the end of the scan. When the count exceeds a predefined maximum value, the scan is presumed done.

BIT PACKING and FRAME analysis are as discussed in Keith Regli's article.

read by a serial IO port. These two circuits demonstrate some of the serial signal conditioning schemes currently in commercial or experimental use. For those of you who wish to input bar coded data in a parallel format, figure 5 shows a block diagram of a software oriented scheme, an analog to digital converter feeding an 8 bit IO port. When using such a parallel voltage level input scheme, your software must handle the task of making a 0 or 1 (white or black) decision instead of the hardware as in the serial schemes of figures 3 and 4.

System Considerations

When working with electro-optical signals a number of factors are vital for a successful scanning system:

1. The printed bar pattern [we take care of this. . . . CH].
2. Use of the hand scanner.
3. Use of a fixed scanner.
4. Low level signal amplification.

1. Though it may seem trivial to worry about printing black bars on white paper and being able to read them, there are problems such as the carbon content of the black ink. Unless the "carbon black" content of the ink is at least 15%, the ink may be invisible in the near infrared which happens to fall in the maximum sensitivity band of the silicon photodetector. For exam-

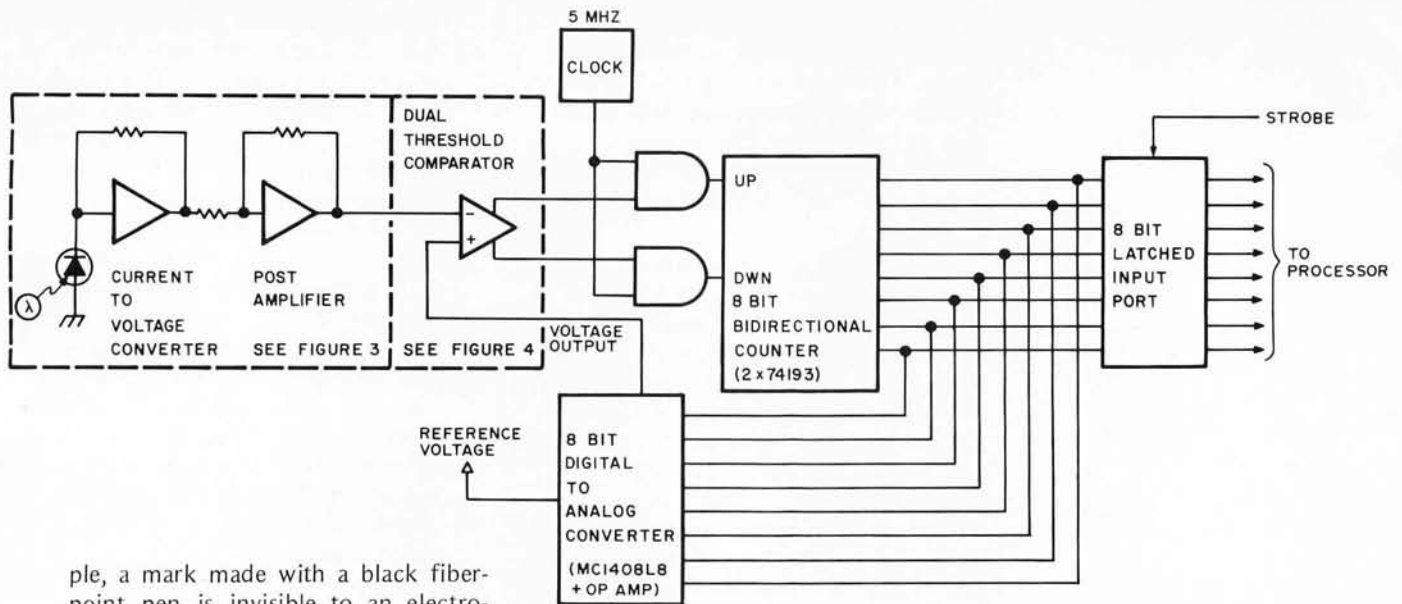

Figure 5: Block Diagram of a Software Oriented Signal Processor. A tracking analog to digital converter connected to an 8 bit port can be used to follow the signal and allow software to implement the peak sampling and bar state determination algorithms. The front end processing of the current to voltage converter and post amplifier would be similar to figures 3 and 4 as noted. A typical 8 bit DAC useful in this application would be the Motorola MC1408L8 part.

ple, a mark made with a black fiber-point pen is invisible to an electro-optical scanner using an incandescent bulb or infrared LED as the light source, yet may be seen by a scanner using a helium-neon laser or red LED as its light source. Of course, in the latter case considerably more gain is needed in the signal conditioning circuitry because the quantum efficiency of the detector is down considerably. The other problem in scanning a printed bar pattern is the grayness of the white paper. The ratio of the white level to the black level is called the contrast ratio and determines the peak to peak signal level seen by the photo-detector.

2. When using a hand scanner that you've built or purchased, the first consideration for a successful line scan is the matter of reading speed. 10 to 30 inches per second (25 to 76 cm per second) is the "normal" scanning speed range. People using a hand scanner, or light pen as it's more normally called, for the first time inevitably scan at a rate too slow for the signal conditioning or for the software counter to handle. The ideal rate is reading from one end of the page to the other (11 inch or 28 cm distance) in about 1/2 second for a reading rate of approximately 22 inches per second (56 cm per second). The second consideration is the acceleration or instantaneous change in scanning speed. This is usually caused by pressing too hard on the paper or guide and thereby reading in a jerky manner as the light pen skips from one rough spot to the next. Normal software techniques that compare a running numerical value of the bar width with that of the running

numerical value of the space width cannot handle more than a 2 to 1 change in instantaneous scanning rate. The third consideration is that of the angle of the light pen to the surface of the paper. Holding the light pen perpendicular to the paper is *not* correct. The best angle is about 15° to 30° from the vertical when the paper surface is lying flat; that is, about the same angle as you hold a pen or pencil when writing. The reason for this strange problem is a condition called "specular reflection." Specular reflection can be experienced by taking a page of BYTE and holding it in such a manner as to cause a bright light to reflect off the paper into your eyes. Notice that the light reflected off the black ink is just about as bright as that reflected off the white surface. Your light pen experiences this same effect when it is held perpendicular to the paper and will cause either a no read or a high error condition. The best signal conditioning and software techniques cannot help.

3. If you build a laser fixed beam scanner to read BYTE's bar coded programs, you might place a page on a fixture mounted on a turntable. Imagine a large coffee can with a guide hole sitting on your turntable, with a page of printed program material taped to it. If the can were 12 inches (30.5 cm) in diameter and turning at 33 rpm, its rotational speed would be about 20 inches per second (51 cm per second), just right for the signal conditioner and hardware to handle; also the same

warning about the light beam being directed perpendicular to the paper applies. One thing more: Make sure all of your optical elements are clean, and dust- and fingerprint-free. It's amazing how often dirt or dust on the optics is responsible for degraded scanner performance.

- When you deal with reflected electro-optic signals, their power level is often in the nanowatt range "down in the mud," so to speak. This is the same range as that of the dark current of the detector (thermal leakage currents) and the ambient noise level. Circuits like that using the "super differentiator" avoid many of the leakage and drift problems but are susceptible to oscillation when adjusted for very high gain. Keep the low level input separated and if possible shielded from the high level output of the first stages. Use no more than 36 inches (about 1 M) of shielded coax between the detector and the low level input amplifier because of the capacitance effects of the cable. Keep the metal case of the light pen at chassis ground and the length of component leads as short as possible. Bypass all active

component power leads with at least 0.1 μ F capacitors and return all ground leads separately to a common point at the ground terminal of the power supply. *Under no conditions* should digital and analog circuits share common power and ground leads, for obvious reasons. Since the gain of the signal conditioning circuits varies from 5,000 (74 db) to 100,000 (100 db) or more, it is critical to carefully lay out and shield circuitry to avoid thermal and microphonic effects. Where possible use input "guarding" of the low level amplifier to further reduce noise effects. (See a discussion of this technique in National Semiconductor's *Linear Applications, Volume 1*, published February 1973.)

In summary, we have covered the basics of light pen or hand scanner optics, detectors, and signal conditioning. We have also discussed some of the considerations in using and building your own scanner and signal conditioner. This article introducing optical scanning is meant only to help you take the first step in a long journey. Hopefully there will shortly be several products on the market to take advantage of these techniques on a regular basis. ■

*The author and BYTE magazine do not assume any responsibility for use of any circuitry described; no circuit patent licenses are implied.

Build a Microcomputer System With This \$7.95 Handbook.

At last, a practical, step-by-step approach to building an operational microcomputer for a bargain price. The *IASIS Microcomputer Applications Handbook* will guide you through all phases of actual design of a working 8080 microcomputer system, including writing a system monitor program. Both development and OEM systems are covered in detail.

Microcomputer Applications Handbook



P.S. If the *Microcomputer Applications Handbook* isn't everything we say it is, return it within 15 days for a full refund.

ORDER BEFORE JAN. 15, 1977 AND WE'LL SHIP YOUR HANDBOOK POSTPAID.

Here's my check or money order for \$7.95. Add \$.50 for postage and handling if ordered after Jan. 15, 1977. (California residents please add \$.52 state sales tax.) Overseas shipments will be made surface unless \$5.00 shipping is added.

Charge to the credit card number below:

BankAmericard No. _____

Master Charge No. _____

For Master Charge, add 4-digit number from right above name. It is: _____

Here's my Signature _____

Credit card expiration date _____

FIRM _____

NAME _____

ADDRESS _____

CITY _____

STATE/ZIP _____

MAIL YOUR ORDER TO IASIS, INC. ■■■■■■■■■■

815 W. MAUDE AVE., SUITE 14 SUNNYVALE, CA 94086

HEY, ALTAIR... GOT THE TIME?

If not, you need COMPTEK's NEW CL2400 Real-time Clock.

- Self-contained hardware clock
- Can be set and read by BASIC
- Programmable interrupts
- Top quality board, components, and I.C. sockets
- ALTAIR and IMSAI compatible
- Uses: 24 hour clock
Software timer
Event timer

KIT — \$98 ASSEMBLED — \$135

comptek

"Real World Electronics"

P.O. Box 516
La Canada, CA 91011

Circle A 207

Audio Design Electronics

Presents A New Concept in Mini/Micro Computer Shops

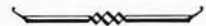

The Computer Emporium

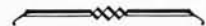

Authorized Dealers for IMSAI, S.W.T.P.Co, O.A.E. Processor Technology, D.B.S. and many others.

Come see our showroom and see the Difference.

Support Service Sales

The Computer Emporium
487 Broadway 510-512
New York, N.Y. 10013
212-226-2038

NEW IN

PHOENIX

Bits & Bytes

COMPUTER SHOP

6819-C N. 21st Ave.
Phoenix, Az. 85015

(602) 242-2507

Featuring:

EPA Micro-68 System
Micro Term-Act 1 Keyboard
Video Monitors
Books, Magazines

GRAND OPENING
Come on In!

THE COMPUTER CORNER

Westchester-Fairfield
Counties

- IMSAI 8080
- POLY-88
- Teletype supplies
- Full line of magazines

- Processor Tech I/O Boards
- Computer Book Service
- Magnetic tapes & disks
- Braingames & puzzles

THE COMPUTER CORNER

White Plains Mall
200 Hamilton Avenue
White Plains, N.Y. 10601
Tel: (914) 949-DATA

Hours:
10-6 Daily & Saturday
10-9 Thursday

Go-Moku!

A true game of pure strategy that operates on any 8080 computer with 2.5K memory.

SIMPLE TO LEARN yet it takes considerable skill to defeat the computer.

THE FULL GAME not just some version simplified for a computer!

DISPLAY the board position on the CRT screen.

Catalog & details \$ 1.95
User's booklet 4.75
Ready to run game 19.95
(with booklet)

RBB Software Products

125 N. Wade Circle
Anaheim, CA 92807

WHAT'S A CREED?

A Creed is a compact, modern and reliable English Teletype. You've probably seen references to Creeds and wondered what they are. We don't advertise much, our business is mostly by word of mouth.

Each Creed includes: keyboard, printer, punch, TTL interface parts kit and manual for \$150, F O B Naperville. The Creed is a Baudot TTY, but Baudot to/from ASCII can be done in hardware or software giving you a heavy duty TTY for a fraction of the cost of a light duty 8 bit TTY.

Interested? Send for free data sheet and price sheet or order a 28 page manual on the Creed and hardware and software interfaces for \$1 (credit given on Creed purchase). Lots of other unique things available, e.g. an optical scanner for \$15 postpaid.

Wilcox Enterprises
25W178-39th Street
Naperville, Il 60540
Phone 312-420-8601

COMPLETE RETAIL & SERVICE COMPUTER OUTLET IN

LONG ISLAND

servicing areas of

QUEENS, NASSAU & SUFFOLK

features

The Personal Computer System IMSAI 8080, kits & assembled, off the shelf. Compatible lines of boards and peripherals. Supporting software. Books, Magazines, Supplies. Advice & full service.

COMPUTER MICROSYSTEMS

1309 Northern Blvd.
Manhasset, N.Y. 11030
516-627-3640

Open Tuesday through Saturday 10-6

SOUTH FLORIDA

We Carry:

- IMSAI
- SWTPC
- Cont. Spec. Corp.
- Vector
- Cromemco

Plus a Wide Selection Of:

Chips • Sockets • Boards
Magazines • Books
Technical Manuals
Newspapers • Brochures

Service and Sales



SUNNY COMPUTER STORES, INC.

University Shopping Center
1238 A South Dixie Hwy.
Coral Gables, FL 33146
(305) 661-6042

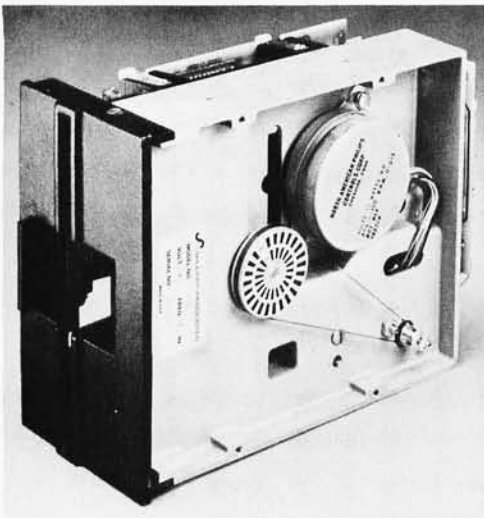

Photo 1: New SA-400 minifloppy disk drive sitting vertically. Shown is belt mechanism which is driven by a DC motor mounted on the top of unit. The door, shown in the open position, cannot be accidentally closed on the media. The minidiskette must be fully seated and centered on the spindle before the door will close and lock, allowing the drive to operate.

The information in this feature is based upon materials supplied by Shugart Associates.

State of the Art Disk Technology

The latest news from Silicon Valley, now confirmed from its source, is the Shugart Associates Minifloppy ["minifloppy" is a Shugart trademark] disk drive for small systems. Its significance is that the price and physical size of random access magnetic recording with removable media has taken another step in the right direction. This drive was specifically designed for uses which:

include word processing and text editing systems, mini and micro program storage, power typing systems, "intelligent" desk top calculators and the emerging microcomputer hobby market.

The parameters of this new design are basically similar to those of a conventional floppy, but reduced in size. The data error ratings include 1 error in 10^{*8} bits for "soft" (recoverable) errors, and 1 error in 10^{*11} bits for "hard" (nonrecoverable) errors. The data rate for the drive is 125 kilobits per second, which is about half a typical conventional floppy's data rate, but far superior to the best of tape cassette drives. Formatted into records of 256 bytes, the drive has a capacity 89,600 bytes. At this capacity, each track contains 10 such records. An alternate recording mode is formatting each track with 18 records of

128 bytes, in which case the track capacity is 2304 bytes and total capacity is 80,640 bytes per drive. If the sophisticated user elects to supply his or her own controller design employing unformatted tracks, the raw capacity of each track is 3125 bytes or 109,365 bytes per drive on line.

Shugart is an old line floppy disk manufacturer, one of the first in the field. The company has delivered more than 40,000 of the model SA800 conventional drive, prior to introducing this new "baby brother" for smaller applications.

The Shugart Minifloppy has a compact package measuring 3.25 inches high by 5.75 inches wide by 8.0 inches long (8.3 cm high by 14.6 cm wide by 20.3 cm long) and weighs three pounds (1.4 kg), yet provides the high precision and mechanical integrity of die cast chassis construction. It features a direct drive stepping motor actuator utilizing a spiral cam with a v-groove positive detent. AC power requirements have been totally eliminated through the use of a DC servo-controlled spindle drive subsystem. An all new 5.25 inch (13.3 cm) minidiskette (Model SA104 soft sectored and Model SA105 hard sectored) has also been developed for the minifloppy drive. The new media is based on today's proven flexible disk technology and will be available from

Photo 2: The new Shugart minidiskette is exactly the same as its larger counterpart, the standard flexible disk, except the size is only 5.25 inches (13.3 cm) square. Minidiskette media comes soft or hard sectored and stores 109.4 K bytes of data (unformatted), or 3125 bytes per track. The media is available from Shugart and several independent media suppliers.

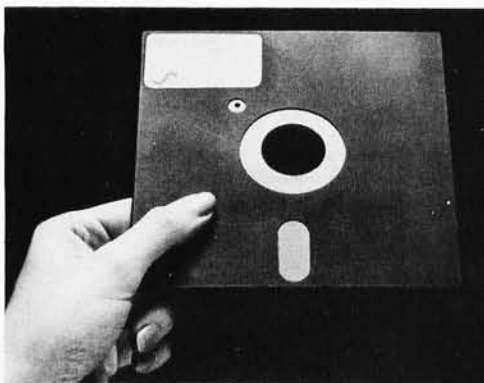

Shugart Associates have trademarked the following terms: Minifloppy, Minidiskette, Ministreaker.

SPECIFICATIONS SUMMARY

SA400 Minifloppy Disk Drive

Disk capacities	109.4 Kbytes (unformatted) 89.6 Kbytes (256 bytes/sector) 80.6 Kbytes (128 bytes/sector)
Track capacities	3125 bytes (unformatted) 2560 bytes (256 bytes/sector) 2304 bytes (128 bytes/sector)
Sector size	128/256 bytes
Tracks	35
Heads	1
Transfer rate	125 Kbits/sec
Seek time	40 ms track to track 463 ms average
Settling time	10 ms
Head load time	75 ms
Average latency time	100 ms
Media	Shugart SA104/105 Minidiskette
Maximum recording density	2581 BPI (103 Bpmm) 5152 FCI (206 fcpmm)
Recording method	FM
Track density	48 TPI (1.89 tpmm)
Rotational speed	300 RPM
Magnetic recording head	Glass bonded ferrite/ceramic

SA104/105 Minidiskette Media

Media	Industry standard flexible diskette Media oxide on 0.003 inch (0.0008 mm) Mylar
Index holes	1
Sector holes	0 (SA104) 16 (SA105)
Jacket	5.25 inch (133.4 mm) square
Disk	5.125 inch (130.2 mm) diameter
Center hole	1.125 inch (25.4 mm) diameter
Media life	3×10^6 passes/track

SA4400 Ministreaker Controller

Drive capability	1 to 3 SA400 Minifloppy units
Total capacity	One drive 80.6 Kilobytes Two drives 161.2 Kilobytes Three drives 241.8 Kilobytes
Format	IBM 3740 format with modified gap structure
Buffer	128 bytes
Data structure	8 bit byte, bidirectional parallel IO
Features	Direct track and sector addressing Asynchronous TTL host interface Seek overlap Simplified command structure
Controller power	5 V at 3 A nominal
Size	7 x 11 inches (177.8 x 279.4 mm)
IO connector	34 pin ribbon or twisted pair connector interface

cost effective interface to allow upward expansion of the units within the system and future system enhancement with the large floppy drive. The drives also provide, as a standard feature, write protect circuitry to protect written diskette information.

Also being introduced along with the minifloppy drive and minidiskette media is the SA4400 ministreaker controller on a 7.0 by 11.0 inch (17.8 cm by 27.9 cm) printed circuit board which utilizes latest generation LSI circuitry to provide up to 241.8 kilobytes of online data storage. The controller board handles one, two or three minifloppy drives.

Using the IBM 3740 format with modified gap structure and a 128 byte buffer, the controller operates with an 8 bit byte bidirectional parallel IO to a microcomputer bus. It also features direct track and sector addressing, asynchronous TTL host interface, seek overlap and a simplified command structure.

This minifloppy drive represents a most significant improvement in the peripherals available to the small systems user. Advanced amateurs can use this machine directly, purchasing the controller and one or more drives in quantities of one from Shugart. Based on the specifications, it should be possible to wire the controller directly to a PIA port on the typical microcomputer and proceed to build a disk operating system in software. In 4 to 6 months, we should see this drive advertised by retailers and manufacturers of kit or finished product computers. For purposes of information and comparison, we print table 1, supplied by Shugart, which gives a rundown of the cost and capacity figures of several media. (Note: the Philips cassette column is oriented towards traditional digital drive manufacturers in both price and capacity estimates; it does not include the lower cost, lower performance drives presently sold to amateurs.)

A small information processing system in a desk top package could easily use two of these drives, an ASCII keyboard, video display output, and 16 K to 32 K of memory as a standard product. Using the disk drive as a key component, such a system could easily run compilers for traditional or new computer languages providing a level of function previously unheard of. We won't

Photo 3: Top view of the new Shugart SA-400 minifloppy disk drive. Shown in upper right is the DC motor which features precision servo speed control and integral tachometer. The large black spiral cam in the center has a ball bearing V groove for positive detent and is connected to the stepping motor. Directly above the cam is the head load pad and proprietary glass bonded ferrite/ceramic read/write head. The read/write head is the same one used in the standard Shugart floppy drive.

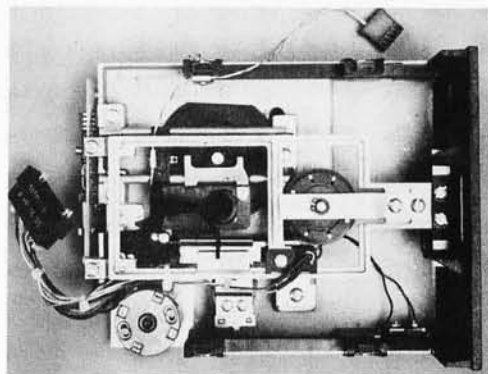

Table 1: Low cost storage products comparison.

	SA400 Minifloppy	SA800 Floppy	3M Mini Cartridge	Philips Cassette	3M Cartridge
Unformatted capacity	110 KB	400/800 KB	100 KB	720 KB	2870 KB
Tracks	35	77	1	2	4
Heads	1	1	1	1	4
Transfer rate	125 Kbits/sec	250/500 Kbits/sec	2.5 Kbits/sec	24 Kbits/sec	48 Kbits/sec
Relative head/media velocity	80 in/sec max	120 in/sec max	30 in/sec	30 in/sec	30 in/sec
Recording density	2600 BPI max	3200/6400 BPI max	800 BPI	800 BPI	1600 BPI
Average access time	566 ms	286 ms	20 s	20 s	20 s
Typical drive size	3.25 x 5.75 x 8.0 in	4.62 x 8.55 x 14.25 in	5 x 5 x 5 in +5 x 12 in PCB	4 x 6 x 8 in	7 x 9 x 12 in
Typical weight	3 lbs	14 lbs	3.25 lbs	5 lbs	5 lbs
Typical power requirements	12 V, 5 V DC	24 V, 5 V, -15 V DC	+12, +5 V DC	+12V, +5 V, -12 V DC	+18, -18 V, +5 V DC
Drive price (qty 1) including head electronics but not controller	\$390	\$600	\$550	\$750	\$1000
Media size	5.25 in sq envelope	8 in sq envelope	2.4 x 3.2 x 0.4 in	4 x 2.5 x 0.4 in	4 x 6 x 0.67 in
Media price (qty 1)	\$4.50	\$6.50	\$16	\$8	\$20

Notes: 1) Average access time = average seek time + average latency time.
2) Typical cassette drive characteristics assumed, including high speed search.

venture to guess what the price of the package will be, but it should certainly be less than \$3000 in the retail store and still retain profit margins for all concerned with its production and distribution. Time will tell at which price such a system will actually hit the market.

List price in quantity one for the minifloppy drive is \$390. OEM quantity pricing

brings the price down to about \$250. Minidiskettes are priced at \$45 for a single box of ten. This drops to about \$35 in large OEM quantities. Ministreaker controllers sell for \$490 in quantity one and for about \$330 in larger quantities. Delivery is 60 days ARO. Shugart Associates, 435 Indio Way, Sunnyvale CA 94086. Phone: (408) 733-0100. ■

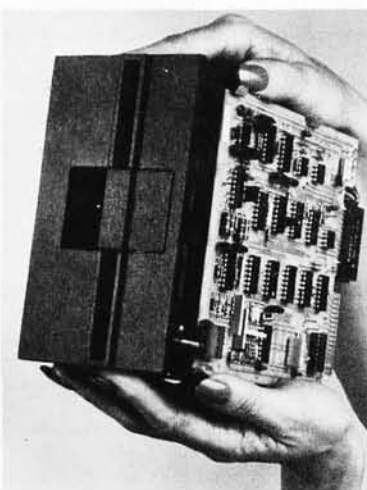

Low Priced Disk System for Altair/IMSAIs

The North Star Micro-Disk System is a complete, high performance floppy disk storage system for use with any Altair/IMSAI compatible computer. The introductory price of \$599 includes everything needed to turn on the computer and start loading or saving programs and accessing online data files.

The disk unit is a compact version of the standard Shugart floppy. Drive capacity is approximately 100 K bytes per diskette. Rotation time is 200 ms. Track to track access is 40 ms. The size of the unit permits mounting of the drive *inside* your computer cabinet with a specified cutout. The power supply requirements (0.5 A at +5 V and 0.9 A at +12 V) permit utilization of your *existing* computer power supply.

What's New?

The North Star controller is a single S100 bus (Altair/IMSAI ...) printed circuit compatible card which can control up to three drives. A PROM contains much of the DOS software including power on startup. The controller operates with or without interrupts as a software option.

The \$599 introductory price covers: the North Star controller (highest quality

printed circuit card and components, with sockets for all integrated circuits, the Shugart minifloppy drive (model SA-400), disk to controller cabling and connectors, two diskettes (one preloaded with the DOS software), complete documentation, limited warranty, and shipping. Additional drives are \$425 each. Diskettes are available for \$4.50 each. A cabinet for mounting up to three drives, with optional power supply, is also available.

Delivery begins late December or January. Orders are now being accepted, either cash in advance or 25% deposit with balance payable COD (including COD charges). BankAmericard accepted with signed order.

For further information write North Star Computers Inc, 2465 Fourth St, Berkeley CA 94710. Phone (415) 549-0858. ■



DEC's LSI-11 Lexicon, Defined

Digital Equipment Corp, Components Group, One Iron Way, Marlborough MA 01752, has published a new pocket sized glossary of computer related terms. The booklet is entitled *The LSI-11 Microcomputer Glossary* and it contains listings with definitions for more than 200 microcomputer related terms covering the hardware and software aspects of systems. Typical terms in this booklet include "trap," "daisy chain," "interrupt vector," etc. The booklet is 44 pages in length and was written primarily to acquaint executives, engineers and sales people with microcomputer related terminology. ■

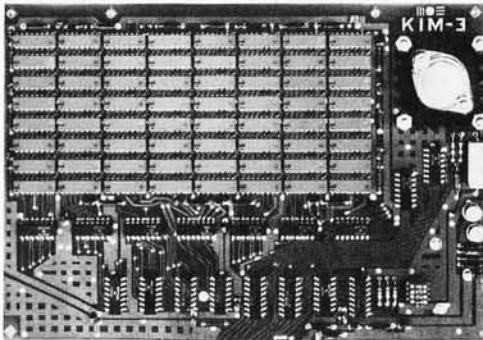
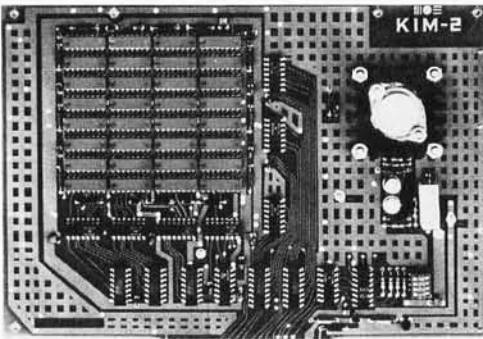

KIM Had Twins?

The latest additions to the KIM line have just been introduced by MOS Technology. These are the KIM-2, a 4 K programmable memory expansion board, and the KIM-3, an 8 K programmable memory expansion board. As with the original KIM module, both of these boards come from the factory completely assembled and tested. They feature high speed low power static memory integrated circuits, so the MOS Technology 6502 processor on KIM-1 can be used flat out at a 1 MHz clock rate. Each board has memory address decoding selection using on board DIP switches (lower right corner of each board in the photos). Thus KIM-2 can be located at any even 4 K boundary in memory address space, and KIM-3 can be located at any even 8 K boundary in memory address space. As with the rest of the KIM line, complete documentation is provided for the board, its installation checkout and operation. Schematics and theory of operation are also provided. Also available is a KIM-4 motherboard to allow expansion of KIM to up to 64 K (65,536) bytes of

memory. The following chart summarizes the specifications of KIM-2 and KIM-3:

	KIM-2	KIM-3
Current required at +5 V (5% regulated) or 8-10 V unregulated	1.5 A	3.0 A
Memory size (8 bit bytes)	4096 bytes	8192 bytes
Price (1-9)	\$179	\$298
Shipping and handling charges (United States and Canada)	\$ 3	\$ 3
International	\$ 15	\$ 15

KIM-2 and KIM-3

Physical Dimensions: 10 by 6½ inches (25.4 by 16.5 cm) exclusive of connector tabs and removal tabs.

Connector: single 44 connection male edge connector. Mating female connector is Vector R644. Connector tabs are centered on 10 inch side of board.

Warranty: 90 days parts and labor.

Memory circuits: 21L02 type memories. 450 ns access time. Suitable for systems using 1 MHz, 2 phase clocks.

Availability: 30 days ARO or better.

MOS Technology is located at 950 Rittenhouse Rd, Norristown PA 19401. ■



Attention Educators: Take a Look at the Texas Instruments Microprocessor Learning System

Three preassembled, add on modules to the Texas Instruments Microprogrammer Learning Module have just been introduced and are available now.

The self-contained units, controller, memory and input/output, complete the user-paced system for understanding microprocessors and provide a training ground for basic software and hardware development.

The basic Microprogrammer Module, which is designed to illustrate the most fundamental level of microprocessor operation, was announced last January. The new modules allow users to progress in a logical sequence from micro to macro level programming to the operation of a fully automated digital system. Each module has its own instruction manual, battery, charger and interconnecting cables and connectors.

The system helps users learn microprocessor concepts and design techniques by providing an insight into the hardware requirements and limitations in designing microprocessor-based systems. Enough system hardware is provided for actual applications limited only by the 4 bit capabilities and the necessary interface circuitry to output devices.

Educators will find the learning modules to be unique tools that allow students to learn how stored program digital systems work through hands-on experience. Students can develop their own macro instructions, write the microcode and observe the sequence of events associated with instruction execution using the microprogrammer.

For those not familiar with fundamental hardware/software relationships, Texas Instruments Learning Center has published a 390 page book, *Software Design for Microprocessors*. The book is an ideal companion

COMPUTALKER



MODEL
CT-1

SPEECH SYNTHESIZER

High Quality Voice Output
Altair/IMSAI/Polymorphic plug-in
Nine Acoustic Control Parameters
Includes 8080 Interface Software
\$395.00 plus shipping

Order a demonstration cassette
\$2.50 postage paid

Write for informative literature

Calif. residents add 6% sales tax

COMPUTALKER CONSULTANTS
P.O. Box 1951, Santa Monica, CA 90406

the microcomputer

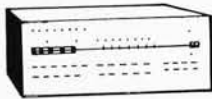

an introduction to
reality

now in canada:

imsai
processor
cromemco
tdl



The Computer Place Focus Scientific
186 Queen St. W 160 Elgin St.
Toronto M5V 1Z1 Ottawa K2P 2C4
416-368-9539 613-236-7767

CHEAP, INC.

7338 Baltimore Ave., Suite 200
College Park, Maryland 20740

Cheap, Inc. is now an IMSAI and
Seals distributor.

295.00 Mnf. Sug. \$
59.00 20% Dis.

236.00
6.00 Shipping
242.00 Our Price

599.00 Mnf. sug. \$
119.80 20% Dis.

479.00
15.00 Shipping
494.20 Our Price

SUPER SPECIAL CHRISTMAS BARGAIN

20% off manufacturer's suggested
list price on kits and assembled
units.

Seals 8K fully buffered memory
board.

Offer may expire Dec. 31, 1976

Write to us for more info on chips,
sockets & floppy disks, also circle
A126.

microcomputers

— Computers for People —
IMSAI 8080

At Special Introductory Prices
(Prices Effective Until December 31, 1976 Only)

I-8080 Kit \$506
I-8080 Kit with 22 Slot Mother \$550

- Add \$9 each for shipping and handling
- New York residents add Sales Tax
- Send check or money order for full amount
(Allow 3 weeks for personal checks.)



WE TAKE MASTERCHARGE
OR BANKAMERICARD



FOR MAIL AND PHONE ORDERS

For orders, information or special prices
on all IMSAI products

Call: (315) 637-6208

Write:

computer enterprises

P.O. Box 71 • Fayetteville, N.Y. 13066

Ask for Our Special Price Sheet.

NECA

PDP-11 : \$698 ??

ALMOST!

NECA IS OFFERING THE DEC LSI-11, A 16 BIT
MICROPROCESSOR BOARD THAT EMULATES AN 11/40
WITH OVER 400 INSTRUCTIONS, FOR \$698 EACH.
YOUR PROCESSOR IS ULTIMATELY ONLY A SMALL
FRACTION OF THE TOTAL SYSTEM COST. THE LSI-11
ACCEPTS FORTRAN, COBOL, BASIC, RT-11, AND OTHER
DEC SOFTWARE.

NECA, THE NORTH EAST COMPUTER ASSOCIATION,
IS A PURCHASING COOPERATIVE ESTABLISHED TO MAKE
DISCOUNT PURCHASES AT OEM PRICES TO BENEFIT THE
INDIVIDUAL CONSUMER.

OPERATE THE LSI-11 WITH A LOW PRICED PAPER
TAPE/CASSETTE SYSTEM NOW, AND ADD A 5 MEGABYTE
DUAL HARD DISC (DEC COMPATIBLE) FOR ABOUT \$2500
THROUGH NECA.

FOR DETAILS AND MORE INFORMATION, PLEASE
WRITE:

N.E.C.A. 834 LAWLOR ST. PHILA., PA. 19116

TURN ON WITH COMPTEK

Circle A127

Now your micro can control AC
power outlets with **COMPTEK's NEW
PC3200** Power Control System.

- 1 to 32 independently address-
able control channels
- Remote power control units —
no AC power on logic board
- Optically isolated, current lim-
ited, low voltage control lines
- Accessible through most BASIC's
- ALTAIR and IMSAI compatible

Write today for more details!

comptek

"Real World Electronics"

P. O. Box 516
La Canada, CA 91011

to the learning system, especially for non-technical professionals, and is designed to give the reader an understanding of the basics of microprocessor machine code and assembly language.

Requests for information should be sent to Texas Instruments Inc, Inquiry Answering Service, POB 5012, M/S 308 (Attn: MP Modules), Dallas TX 75222. ■

Use a High Resolution Text Display

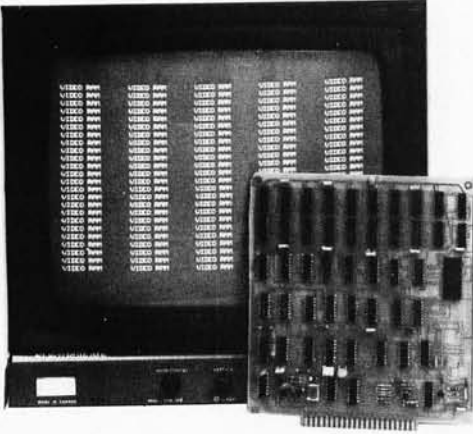

by
David Jon Fylstra
POB 10051
Stanford CA 94305

Most homebrewed video displays these days have 32 to 40 characters per line, with perhaps 16 lines. An occasional lucky person has a high-bandwidth monitor, with up to 64 characters per line. But for many applications, such as text editing and word processing, this just isn't enough — the industry standard of 80 characters per line would be far more suitable.

If you're considering a video display, take a serious look at a new line of components introduced by Matrox Electronic Systems of Canada. The video RAM (VRAM) is a small module which stores all of the screen characters in its internal random access memory, and generates an EIA standard 75 ohm output, complete with horizontal and verti-

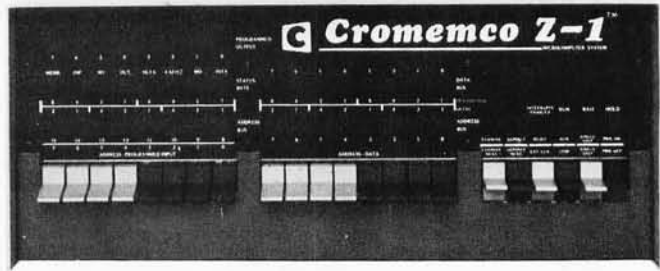

If You Z-1, You Z Them All!

Cromemco has announced a new processor, available with stock to 60 days delivery, which is intended as a "plug in and turn on" method of obtaining a Z-80 computer system. The product looks very suspiciously like another well known computer which has been assembled with a custom screened front panel and Z-80 card. For \$2495, your cold hard cash will purchase the following standard configuration from Cromemco:

- Z-80/4 microprocessor and mainframe with 22 card sockets, 28 A power supply.

- 8 K bytes of programmable memory.
- "ByteSaver" PROM card with room for 8 K 2704 or 2708 PROM and PROM burner.
- PROM monitor program.
- RS-232 serial IO interface.

Add your own RS-232 terminal to the system, plug in the power, and enjoy the fruits of the block move, block IO and block search instructions in your programming, to say nothing of the relative and direct addressing modes of the Z-80 chip. Cromemco is located at 2432 Charleston Rd, Mountain View CA 94043. ■

cal sync signals, which can be connected directly to your video monitor.

While the Matrox VRAM modules are available in a variety of formats (8 line X 16 characters, 16 X 32, 16 X 64, and 32 X 64), of particular interest is the MTX-2480, which generates the standard 24 line by 80 character format in full upper and lower case ASCII. This 6.5 X 6 inch (16.51 X 15.24 cm) module can be tied directly to the address and data bus of any microprocessor, and requires a mere single +5 V, 1 A power supply. Especially appealing is the organization of the address and data bus: in the 12 bit address, 5 bits indicate the line to be accessed, and 7 bits select the character, making it simple to generate a carriage return and line feed sequence when filling the screen — just zero the 7 bit character counter in your program, and bump the 5 bit line counter up 1 bit. The 9 bit data bus is divided into a 7 bit field to select the

ASCII character, and a 2 bit control field which allows any individual character on the screen to be black on white, white on black, blinking, or half intensity. While any character can be accessed directly at any time (access time < 650 ns), two pins of this 28 pin module are provided to indicate horizontal and vertical blanking retrace intervals. Writing characters into the VRAM during these retrace intervals will result in a truly flicker free display.

The MYX-2480 is available from Matrox for \$395 in unit quantity FOB Montreal (with generous quantity discounts), delivery time 4 to 8 weeks. The module is available in several character fonts, including the standard upper and lower case alphanumerics with Greek letters, general European, French, and Japanese Kata-Kana. Matrox Electronic Systems may be reached at POB 56, Ahuntsic Stn, Montreal, Quebec H3L3N5 CANADA. (514) 481-6838. ■

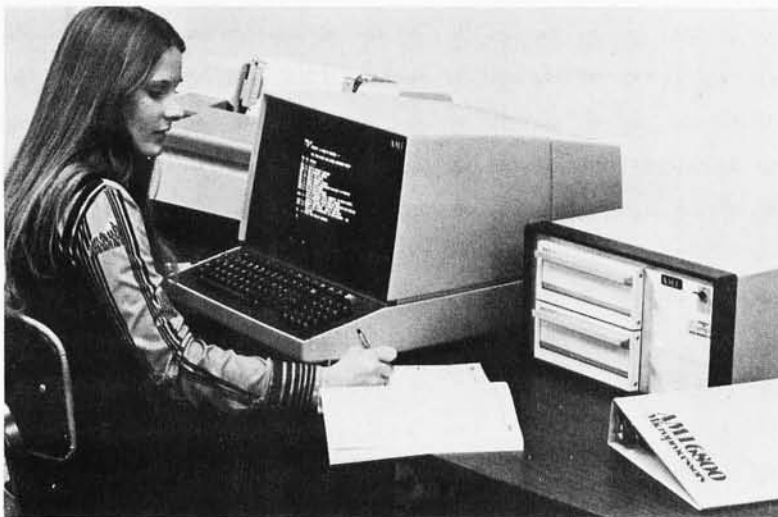

A System Product with a Software Orientation

Picture this as your general purpose computer system. American Microsystems Inc has introduced the AMI 6800 microcomputer development center, a stand alone 6800 system with dual floppy disk, printer and video terminal options. While it can easily serve as a system for the development of industrial microcomputers, it can also be used as a general purpose data processing system in business, and as an intelligent communications terminal. By paying attention to such end user applications, AMI has done more than just reinvent the wheel of design aids for engineers in commercial and industrial shops. Local dealers would be well advised to consider this system as a product for possible sale to business and high end amateur customers. Contact AMI at 3800 Homestead Rd, Santa Clara CA 95051. ■

Software Bug of the Month 6

Prudence was writing her own sine routine on her trusty mini, using the formula

$$x - \frac{x^3}{3!} + \frac{x^5}{5!} - \frac{x^7}{7!} + \dots \text{ which}$$

converges to $\sin(x)$

Noticing that she could get from the term with denominator $n!$ to the next term by multiplying by $-x^2$ and dividing by $n+1$ and then again by $n+2$, she wrote the following FORTRAN program:

```
Z = X
SUM = X
N = 1
1 Y = N + 1
Z = -Z*X*X/(Y*(Y+1))
SUM = SUM + Z
N = N + 2
IF (ABS(Z) .GE. 0.00001) GO TO 1
SINE = SUM
```

In went the floating point package! In went the sine routine! Out came the sines! Great!

But Prudence was nothing if not prudent. She decided to test her program over a really wide range of values. And this time something very strange happened. Most of the values were all right, but some of them were wildly wrong. The problem was particularly galling because none of the easy values — sine of 0° , 30° , 60° , 90° — were off. In short, it looked like the kind of routine that could be used for years without error, and then, when somebody needs a really weird value, it conks out.

Prudence's first thought was to try it with the double precision floating point package. Unfortunately, the answers came out almost exactly the same as before. Can you spot Prudence's problem? ■

Answer in Next Month's BYTE



SOLUTION TO BUG OF THE MONTH 5

Did we fool you?

There were two bugs last time!

The first bug was in the operation of interchanging the values of $PR(I)$ and $PR(I+1)$. You simply don't interchange X and Y by setting $X = Y$ and then $Y = X$. If you haven't figured this out yet, consider:

setting $Y = X$ sets Y equal to the *new* value of X , which is the old value of Y — in other words, it doesn't change anything. Or, to put it another way, setting $X = Y$ destroys the old value of X , never to be recovered.

What Private Preston should have done at steps 5 and 6 was something like the following: Set $TEMP$ equal to $PR(I)$; then set $PR(I)$ equal to $PR(I+1)$; finally, set $PR(I+1)$ to $TEMP$. Or, in machine language: Load register U with $PR(I)$; load register V with $PR(I+1)$; store register U in $PR(I+1)$; finally, store register V in $PR(I)$.

The second bug was in the very last step. We want to go to step 1 if K is *unequal* to zero — that is, if there *have* been any interchanges. If there have been no interchanges, we are done, and we want to go on to the next statement.

There was one "bug" here that isn't really a bug. It is in step 8, where we tested whether I was *unequal* to 50. Normally, this isn't the right way to end a loop, because it misses the last case; we only do $I = 1$ up through $I = 49$. However, in this program, it should be clear that we *want* to miss the last case. We don't want to set I equal to 50, because then we would be comparing $PR(50)$ with $PR(51)$, which doesn't exist. ■

W Douglas Maurer
University Library Room 634
George Washington University
Washington DC 20052

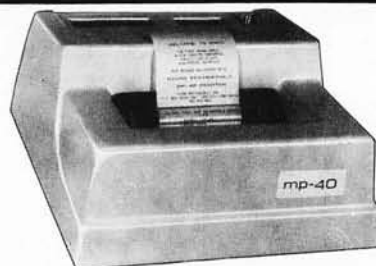

The completely assembled and tested MP-40 printers continue to be the favorite of commercial users and hobbyists alike. Featuring a 5X7 impact dot matrix, 40 columns, 75 lines per minute, 4" adding machine paper, molded casework, zinc-plated chassis and power supply. Choose from one of these three interface models.

- **LCP** • 8-bit Parallel I/F without character generator for special software fonts **\$329**
- **ASCII** • 8-bit Parallel Interface with a 64 character ASCII set **\$425**
- **SSP** • Intelligent RS232 or Current Loop data terminal. Async Serial I/F **\$499***

*Introductory price for prepaid orders are good until Dec. 31, 1976

OR SELECT THE "NO FRILLS" KP-40 KIT

- Mechanism, LCP I/F PC board & components
- Power transformer and assembly instructions **\$179**

SEND FOR FREE LITERATURE

Master Charge Welcome • Utah Residents Add 5% Sales Tax

mpi/P.O. BOX 22101/SALT LAKE CITY/UT/84122
(801) 566-0201

Here is a spot, concocted partly in response to Craig A Pearce's letter ["Snob Detector," page 53], for examples of creative uses of programmable calculator products. We start this off with SHOOTING STARS, expressed in the form of a program for the SR-52 calculator by Texas Instruments, with the PC-100 printer attachment.

Desk Top Wonders

SHOOTING STARS (for the SR-52 and PC-100 Printer)

by

Craig A Pearce
2529 S Home Av
Berwyn IL 60402

Instructions:

- Note: Before recording program card 2 (play section) onto a magnetic card, perform the following steps:
A. Input the number 222212222
B. Press: STO, 9, 7
C. Record in the usual manner

1. Input initialization card (card #1) and press C.
2. Printer will show the 9 star positions by their number on the thermal paper strip. The LED display shows the same positions in an in-line fashion.

Program Listings

(Initialization Card):

000 *LBL C	002 .1245	007 STO 11
010 .123	014 STO 12	017 .2356
022 STO 13	025 .147	029 STO 14
032 .24568	038 STO 15	041 .369
045 STO 16	048 .4578	053 STO 17
056 .789	060 STO 18	063 .5689
068 STO 19	071 123 *prt	075 456 *prt
079 789 *prt	083 12345	088 6789
092 *pap *rtn		

(Game Play Card):

000 *LBL A HLT	003 *B' - 1 =	007 INV *ifzro 018
012 += *prt *pap	016 GTO A	018 1 SUM 10
022 RCL 98	025 + 10 =	029 *B' STO 99
033 10 *PROD 99	038 RCL 99 -	042 1 EE 12 +
047 1 EE 12 =	052 INV EE	054 *ifzro 105
058 INV SUM 99	062 *B' - 1 =	066 *ifzro 072
070 2 ÷	072 2 =	074 *IND STO 98
078 GTO 033	082 *LBL E	084 0 STO 10
088 9 STO 00 1	093 *IND STO 00	097 *dsz 093
101 2 STO 05	105 0 STO 99	109 1 STO 98
113 3 STO 00	117 1000 *PROD 99	124 *IND RCL 98
128 x (RCL 00 -	134 1) INV *log	138 = +
140 1 SUM 98	144 *dsz 124	148 0 = *prt
151 SUM 99	154 RCL 98 - 10 =	161 INV *ifzro 113
166 RCL 97 -	170 RCL 99 =	174 INV *ifzro 184
179 RCL 10 +/- *prt	184 *pap RCL 99	188 GTO A
190 *LBL *B'	192 STO 98	195 *IND RCL 98 *rtn

3. Load in the play card (card 2) — both A & B sides.
4. For a new game, press: E
5. Printer will show the star field at the start of the game:

```

1 1 1
1 2 1
1 1 1

```

6. Each 1 represents a black hole. Each 2 represents a star.
7. Following standard rules of play (shooting stars only) the user inputs the star position to be shot and keys:

RUN

for each move of the game. The star field is reprinted with the stars affected by the shot having been modified (stars become black holes and vice versa). The object is to end up with a star field as follows:

```

2 2 2
2 1 2
2 2 2

```

8. When the game is completed correctly, the number of turns used in the game will be displayed just below the final grid pattern as a negative number. This number can be recalled at any time by pressing: RCL 10
9. If no moves are possible, (all positions are filled with black holes), the game has been lost. Shooting a black hole causes the display to blink and the PC-100 to print: 0. ?
Before continuing, press CE to stop blinking.
10. To begin a new game, go to line 4 above.

How Shooting a Star Affects Its Neighbors

All affected neighbors will change from stars to black holes and vice versa when a star is shot.

Patterns are shown below.

```

1 # * # 2 # * # 3
# # * * * * # #
* * * * * * * *
# * * * # * * * #
4 * * # 5 # * * 6
# * * * # * * * #
* * * * * * * *
# # * * * * * # #
7 # * # 8 # * # 9

```

KEY:

- * — unaffected position
- # — position that is affected
- n — (where $1 \leq n \leq 9$) the star that was shot

Some Conventions Used in the Listings

* — denotes pressing on the 2nd key prior to the indicated one. Programs are read left to right, across all three columns before proceeding to the next line. The three digit number at the start of each column is the starting line number for the first of the instructions that follow it.

Warnings and Limitations

Shooting a black hole will cause a flashing display to indicate an error. Clear error condition by pressing CE before continuing.

No error checks have been added to detect illegal entries (<1 or >9 or noninteger inputs). User should avoid making these types of entries.

Program History

Originally submitted to the Hewlett-Packard software library, this program was printed in BASIC in Peoples' Computer Company's newsletter September 74, under the title TEASER.

Most recent printing was a machine code program (for the Intel 8008 chip) in the May 1976 issue of BYTE magazine by Willard I Nico.■

SPEED UP YOUR 8080 WITH A HARDWARE FLOATING POINT BOARD

The North Star Floating Point Board (FPB-A) performs add, subtract, multiply and divide on BCD format floating point values. Speed is **50 times faster** than 8080 software. Precision is software selectable up to 14 digits. Plugs directly into your Altair or IMSAI to dramatically improve program performance and reduce memory requirements by about 1k.

A special version of our fast and powerful **extended** BASIC which uses the North Star FPB-A is supplied with every order.

Included: Highest quality PC card and components, sockets for all IC's, BASIC manual and object tape, complete documentation, limited warranty, and shipping.

Kit: \$359. Assembled \$499. Cal. res. add sales tax. BankAmericard accepted with signed order. Delivery from stock.

NORTH STAR COMPUTERS
2465 Fourth Street, Berkeley, CA 94710

BYTE FILES / BINDERS

Preserve those precious first 16 issues with either a handsome but rugged library file—or a binder—in flag blue Kivar library fabric stamped in gold leaf.



Files: Made to hold the first 16 issues of BYTE. Price per file \$4.95; three for \$14; six for \$24, postpaid.

Binders: Made to hold the first 16 issues of BYTE. Price per binder \$6.50; three for \$18.75; six for \$36, postpaid.

(Add \$1 each outside USA.)

Send to: **BYTE, POB 5120, Philadelphia PA 19141**

I enclose check or money order for \$_____

Please send me _____ BYTE _____ Files _____ Binders

Name _____
(please print)

Address _____

City _____

State _____ Zip _____

Satisfaction guaranteed or money refunded. Allow at least four weeks for delivery.

Potpourri from BITS™

BITS, Inc, is a trademark of BYTE Interface Technical Services, Inc.

It's Almost Too Late . . .

. . . to snap up bicentennial memorabilia before you have to hunt through the nostalgia shops and pay 100 times the original price—if you're lucky enough to find a bargain—for an item as anachronistic and otherwise remarkable as Robert Tinney's Computing 1776 picture.

A same-size (16 by 20 inches, 41 by 51 cm) reproduction of Tinney's original oil painting, this poster makes an off-beat gift.

Don't wait for the nostalgia shops to get the last of these posters; get yours now for only \$2.95. (Do you know what your old Amazing Science Fiction magazines and Superman comics that Mom threw out are worth now?)



COMPUTER



Have you ever wondered where to go for a basic starting point in your quest for information about computer applications and uses? Ted Nelson's book, *Computer Lib/Dream Machines*, is the place for you to begin.

Computer Lib/Dream Machines is for the layman — the person who is intelligent and inquisitive about computers. It is written and self published by a philosopher who is also a self confessed computer fan and an excellent teacher of basic concepts. (For those who have not yet heard, ivory towers are constructed out of real and substantial white bricks.)

Computer Lib/Dream Machines is must reading for the beginner, and is also a refreshing self examination for the old hand at programming and systems work.

BYTE T-shirts

Available in blue heather with blue trim and red letters, or in white with blue trim and red letters. Only \$5, including postage and handling.



Please send me:

_____ copies of Computer Lib @ \$7	50 cents postage per copy _____	Total _____
_____ T-shirts	_____ extra large	_____ blue heather, blue trim, red letters
	_____ large	
	_____ medium	
	_____ small	_____ white, blue trim, red letters @ \$5
_____ posters @ \$2.95		Total _____
		Total _____



Check payment method:

_____ My check is enclosed	
_____ Bill my MC No. _____	Exp. date _____
_____ Bill my BAC No. _____	Exp. date _____

Send to: BITS, Inc
70 Main St
Peterborough NH 03458

Name _____

Address _____

City _____ State _____ Zip _____

Signature _____

Please allow six weeks for delivery.

You may photocopy this page if you wish to leave your BYTE intact.

A Modern High Level Language Self Compiler — At Last!

A software development house, called Administrative Systems Inc, located at 222 Milwaukee, Suite 102, Denver CO 80206, has announced the availability of what looks (from the advance description) like an excellent proprietary language system for 8080 based microcomputer users. This product is the Opus/One high level language compiler.

Opus/One comes in two versions, both of which require 8 K bytes of memory to operate. The disk version of the compiler sells for \$300, and the audio cassette tape version sells for \$250. This is probably the first high level language compiler designed and marketed explicitly for the small systems user, and it will prove attractive both to the businessman and to the professional user of these computers. Here is what the investment purchases for the user:

According to ASI, Opus/One is "a high level language compiler that is faster and more efficient in memory utilization, yet is as simple to learn as BASIC. It incorporates the strong points of several large system languages such as ALGOL and FORTRAN, yet maintains the commands, statements and simplicity of BASIC. The nonprofessional will find programming easy and straight-

forward; the professional will discover that many unique and creative combinations of code are possible, enhancing program efficiency and power . . ."

The documentation received at BYTE so far (August 20 1976) consists of a short listing of Opus/One features, which make it one of the most exciting new products in this month's pages of BYTE. Summarizing, Opus/One has:

- **Block Structure.** A BEGIN . . . END bracket similar to ALGOL, used as part of the IF . . . THEN . . . ELSE structure, eliminates unneeded GO TO statements and labels. This feature is a key to high reliability "structured programming."
- **Variables.** Unrestricted character length names; number, string or matrix data types.
- **Numbers.** Precision to 126 decimal digits, variable. Automatic string conversions when needed.
- **Strings.** Length to 128 characters, with substring and concatenation operations, automatic conversions to numerical values when needed.
- **Matrices.** Up to 255 dimensions, string or numeric data types, used to struc-

ture blocks of data within programs.

- **Disk Files.** Dynamically created and referenced by logical record number; fixed length records of up to 136 bytes per record.
- **Functions.** Built in functions include output formatting, number and string manipulation, device IO, standard mathematical functions, random number generator.
- **Miscellany.** The language uses line numbers only for editing and debugging, incorporates print formatting statements needed to help create reports on output devices, a run time command mode of operation with debugging features, and IO drivers for most common peripherals including ASCII RS-232 or current loop devices, floppy disk systems and cassette tape units.

In short, it sounds as if the advance description of Opus/One makes it exactly what is needed to turn a small system into the equivalent of many very expensive traditional systems based on minicomputers. The availability of Opus/One was announced as 30 days delivery, beginning September 15 1976. A users manual is available for \$5. ■

BYTE'S BITS

No Back BYTES

Attention BYTE Lovers: Due to the avalanche of enthusiasm evidenced by our readers, the entire supply of BYTE back issues is now exhausted. Thus the only way to get back BYTES is through appropriate horse trading at your local computer club or computer fest. ■

What Is It?

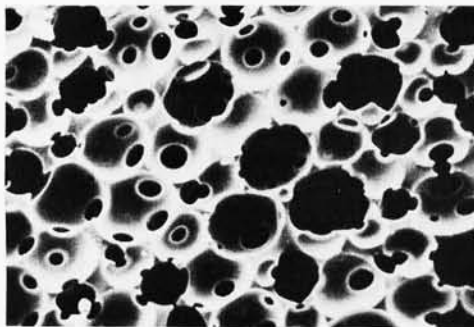

Here is a photo of a cross section of a product which has some relevance to computer technologies, and makes an interesting puzzle. Let's see who comes closest to guessing the identity and purpose of this product in letters postmarked by December 10 1976. ■

Attention Rhode Island Hackers

Computer Power Inc is the name of the new computer store which opened September 4 at the Airport Plaza, 1800 Post Rd, Warwick RI. According to the announcement we received, the store is easily reached from Interstate 95 by taking the State Airport exit in Warwick. Hours will be 1 PM to 8 PM, Monday-Friday, 10 AM to 6 PM Saturday.

CPI carries IMSAI, Processor Technology and Cromemco products, as well as the general supplies and products needed by computer enthusiasts. Southern New England individuals will find this store a welcome addition to the roster of retail outlets for computer equipment and supplies. ■

Dallas Area Hackers Take Note

The Micro Store is the place to go in the Dallas area, the first computer store to open serving that city. Opened June 19, at 634 South Central Expressway in Richardson TX, the Micro Store offers an array of products and services for the computer hobbyist and small business person, including several different computer lines, parts, peripherals, prototyping equipment, books, magazines, repair services, software and consulting. The major product lines at the Micro Store are Southwest Technical Products, IMS Associates, Polymorphic Systems, Cromemco, Processor Technology, and Vector Electronics.

The store is a family operation run by the husband and wife team of David Wilson and Portia Isaacson. David, a long time computer hobbyist with an MS degree in computer science and extensive professional experience on small computers, is responsible for the daily operation of the store; Portia, who is assistant professor of Computer Science at the University of Texas in Dallas, provides consulting and guidance to the store.

AFIPS NCC Proceedings Are Now Available

The 1976 *Proceedings of the National Computer Conference (NCC)* has just been published by the AFIPS Press. The conference is sponsored yearly by AFIPS, the American Federation of Information Processing Societies and its four member groups. The 1976 conference, as noted earlier in BYTE, was held in New York City (the 1977 conference will be in Dallas). *Proceedings* is a heavy (1082 page) document in hard cover, which is available for \$50, with a 50% reduction for prepaid orders from members of one of the AFIPS Constituent Societies. Write the AFIPS Press at 210 Summit Av, Montvale NJ 07645, and give your ACM or IEEE membership number for the discount.

This year's NCC proceedings contains 136 papers in the following areas:

Computers and People — computer privacy, computer security, computer abuse, computer cryptography, EFTS, education and training, computer graphics, computers and the physically handicapped, public access to computers, medicine and health care, criminal justice systems, and computers in architecture.

Systems — computer system design, microprocessors, minicomputers, computer system management and planning, computer system performance and evaluation, computer networking in the US and Europe, word processing and office automation, computer-assisted manufacturing, and computer-controlled publication.

Science and Technology — computer architecture, multiprocessor systems, data base systems, large scale networks, programming, software design and engineering, and artificial intelligence. ■

Hours are 11 AM to 9 PM weekdays, and 9 AM to 6 PM Saturdays. ■

101 Basic Computer Games

David H. Ahl. An anthology of games and simulations—from Acey-Deucey to Yahtzee, all in the BASIC language. Contains a complete listing, sample run, plus a descriptive write-up of each game. Our most popular book! Large format, 248 pp. \$7.50 [6C]

What to Do After You Hit Return

Another collection of games and simulations—all in BASIC—including number guessing games, word games, hide-and-seek games, pattern games, board games, business and social science simulations and science fiction games. Large format. 158 pp. \$6.95 [8A]

Fun & Games with the Computer

Ted Sage. "This book is designed as a text for a one-semester course in computer programming using the BASIC language. The programs used as illustrations and exercises are games rather than mathematical algorithms, in order to make the book appealing and accessible to more students. The text is well written, with many excellent sample programs. Highly recommended." —*The Mathematics Teacher* 351 pp. \$5.95 [8B]

Game Playing With the Computer, 2nd Ed.

Donald Spencer. Over 70 games, puzzles, and mathematical recreations for the computer. Over 25 games in BASIC and FORTRAN are included complete with descriptions, flowcharts, and output. Also includes a fascinating account of the history of game-playing machines, right up to today's computer war games. Lots of "how-to" information for applying mathematical concepts to writing your own games. 320 pp. 1976 \$14.95 [8S]

BYTE Magazine

If you are considering a personal computing system now or later, BYTE provides a wealth of information on how to get started at an affordable price. Covers theory of computers, practical applications, and of course, lots of how-to build it. Monthly. 1-Year sub'n \$12.00 [2A], 3-Years \$30.00 [2B]

Games & Puzzles Magazine

The only magazine in the world devoted to games and puzzles of every kind — mathematical, problematical, crosswords, chess, gomoko, checkers, backgammon, wargames, card games, board games, reviews, competitions, and more. Monthly. 1-Year sub'n \$12.00 [3A]

Games With The Pocket Calculator

Sivasailam Thiagarajan and Harold Stolovitch. A big step beyond tricks and puzzles with the hand calculator, the two dozen games of chance and strategy in this clever new book involve two or more players in conflict and competition. A single inexpensive four-banger is all you need to play. Large format. 50 pp. \$2.00 [8H]

Games, Tricks and Puzzles For A Hand Calculator

Wally Judd. This book is a necessity for anyone who owns or intends to buy a hand calculator, from the most sophisticated (the HP65, for example) to the basic "four banger." 110 pp. \$2.95 [8D]

So you've got a personal computer.

Now what?

Creative Computing Magazine

So you've got your own computer. Now what? *Creative Computing* is chock full of answers — new computer games with complete listings every issue, TV color graphics, simulations, educational programs, how to catalog your LPs on computer, etc. Also computer stories by Asimov, Pohl, and others; loads of challenging problems and puzzles; in-depth equipment reports on kits, terminals, and calculators; reviews of programming and hobbyist books; outrageous cartoons and much more. *Creative Computing* is the software and applications magazine of personal and educational computing. Bi-monthly.

1-year sub'n \$8.00 [1A], 3- years \$21.00 [1B], sample copy \$1.50 [1C]

The Best of Creative Computing — Vol. 1

David Ahl, ed. Staggering diversity of articles and fiction (Isaac Asimov, etc.), computer games (18 new ones with complete listings), vivid graphics, 15 pages of "foolishness," and comprehensive reviews of over 100 books. The book consists of material which originally appeared in the first 6 issues of *Creative Computing* (1975), all of which are now out of print. 324 pp. \$8.95 [6A]

Computer Lib/Dream Machine

Ted Nelson. This book is devoted to the premise that everybody should understand computers. In a blithe manner the author covers interactive systems, terminals, computer languages, data structures, binary patterns, computer architecture, mini-computers, big computers, microprocessors, simulation, military uses of computers, computer companies, and much, much more. Whole earth catalog style and size. A doozy! 127 pp. \$7.00 [8P]

Computer Power and Human Reason

Joseph Weizenbaum. In this major new book, a distinguished computer scientist sounds the warning against the dangerous tendency to view computers and humans as merely two different kinds of "thinking machines." Weizenbaum explains exactly how the computer works and how it is being wrongly substituted for human choices. 300 pp. \$9.95 [8R]

Artist and Computer

Ruth Leavitt, ed. Presents personal statements of 35 internationally-known computer artists coupled with over 160 plates in full color and black & white. Covers video art, optical phenomena, mathematical structures, sculpture, weaving, and more. 132 pp. \$4.95 [6D] Cloth cover \$10.95 [6E]

Computer Science: A First Course (2nd Ed.)

Forsythe, Keenan, Organick, and Stenberg. A new, improved edition of this comprehensive survey of the basic components of computer science. There has been an updating of important areas such as Programming, Structured Programming, Problem Solving, and other Computer Science Concepts. The quantity of exercises and problems has been increased. 876 pp. \$16.95 [7D]

Mr. Spock Poster

Dramatic, large (17" x 23") computer image of Mr. Spock on heavy poster stock. Uses two levels of overprinting. Comes in strong mailing tube. \$1.50 [5B]

Problem Solving With The Computer

Ted Sage. This text is designed to be used in a one-semester course in computer programming. It teaches BASIC in the context of the traditional high school mathematics curriculum. There are 40 carefully graded problems dealing with many of the more familiar topics of algebra and geometry. Probably the most widely adopted computer text. 244 pp. \$5.95 [8J]

A Simplified Guide to Fortran Programming

Daniel McCracken. A thorough first text in Fortran. Covers all basic statements and quickly gets into case studies ranging from simple (printing columns) to challenging (craps games simulation). 278 pp. \$8.75 [7F]

Understanding Solid State Electronics

An excellent tutorial introduction to transistor and diode circuitry. Used at the TI Learning Center, this book was written for the person who needs to understand electronics but can't devote years to the study. 242 pp. \$2.95 [9A]

Microprocessors

A collection of articles from *Electronics* magazine. The book is in three parts: device technology; designing with microprocessors; and applications. 160 pp. 1975 \$13.50 [9J]

Microprocessors: Technology, Architecture and Applications

Daniel R. McGlynn. This introduction to the microprocessor defines and describes the related computer structures and electronic semi-conductor processes. Treats both hardware and software, giving an overview of commercially available microprocessors, and helps the user to determine the best one for him/her. 240 pp. \$12.00 [7C]

Problems For Computer Solution

Gruenberger & Jaffray. A collection of 92 problems in engineering, business, social science and mathematics. The problems are presented in depth and cover a wide range of difficulty. Oriented to Fortran but good for any language. A classic. 401 pp. \$8.95 [7A]

A Guided Tour of Computer Programming In Basic

Tom Dwyer and Michael Kaufman. "This is a fine book, mainly for young people, but of value for everyone, full of detail, many examples (including programs for hotel and airline reservations systems, and payroll), with much thought having been given to the use of graphics in teaching. This is the best of the introductory texts on BASIC." —*Creative Computing* Large format. 156 pp. \$4.40 [8L]

BASIC Programming 2nd Ed

Kemeny and Kurtz. "A simple gradual introduction to computer programming and time-sharing systems. The best text on BASIC on almost all counts. Rating: A+." —*Creative Computing*. 150 pp. \$8.50 [7E]

CREATIVE COMPUTING, Dept. B
P.O. Box 789-M, Morristown, NJ 07960

Please send me the following:

Quan.	Cat.	Description	Price
_____	_____	_____	_____
_____	_____	_____	_____
_____	_____	_____	_____

Books Shipping charge \$1.00 USA, \$2.00 Foreign _____

NJ Residents add 5% sales tax _____

Cash, check, M.O. enclosed TOTAL _____

BankAmericard } Card No. _____

Master Charge } Expiration date _____

Name _____

Address _____

City _____ State _____ Zip _____

The Designer's Eye View of

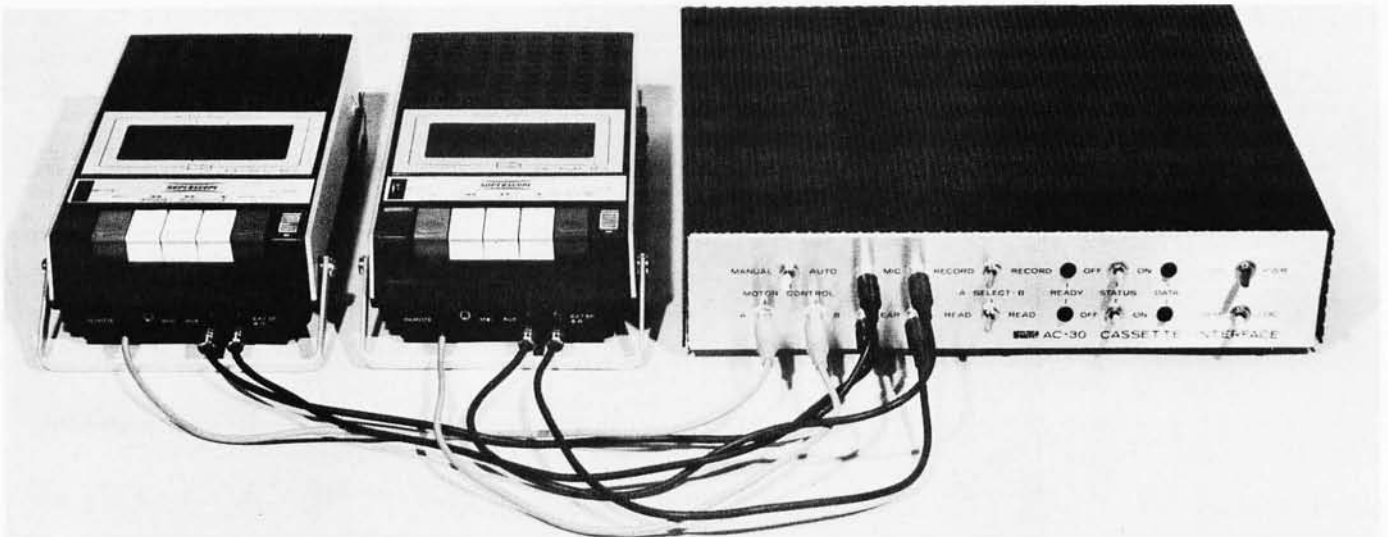

Photo 1: The AC-30 Cassette Interface Unit shown in its natural arrangement with a couple of inexpensive cassette recorders. The cables going from the AC-30 to the recorders can be fabricated at home from standard high fidelity cables cut in half, or complete cables can be purchased to match your recorder to phono style plugs. See your local Radio Shack or equivalent store for such items.

the AC-30

Gary Kay
Southwest Technical Products Corp
219 W Rhapsody
San Antonio TX 78216

Cassette tape is one of the most flexible and least expensive means of mass data storage for computer systems. When compared to paper tape readers and punches, you'll find that although the paper tape readers can be made rather inexpensively, the punches cannot. Paper tape systems are typically slower and the punched tapes cannot of course be repunched and used over and over again, as you can with cassettes. Disk systems on the other hand offer significant advantages over cassettes but are still too expensive for many applications, and for most low cost personal computer users. Even those lucky enough to have a disk system still need a more universal medium for exchanging programs.

Although there are several commercial digital cassette tape decks on the market today, recording techniques vary, and they are of course much more expensive than the average audio cassette unit. As could be expected most hobbyist computer system

mass data storage designs have been based on the audio cassette recorder.

The use of inconsistent recording techniques among the various manufacturers makes it impossible, for example, to record a program, or data tape on a SWTPC 6800 computer system and play it back on a MITS 680 computer system. In order to coordinate manufacturer design efforts, and exploit the most effective recording technique, BYTE magazine sponsored a symposium in the fall of 1975 in Kansas City in an attempt to establish a recording standard for the storage of digital data on audio cassette recorders. The standard which was adopted has been tested and fully supported by Southwest Technical Products Corp. It appears to be the best compromise between economy and reliability. Although complete details are contained in the February and March 1976 issues of BYTE magazine, the recording philosophy is to record data serially using the standard UART format at

300 baud (30 characters per second). Marks or logic ones are represented by recording a 2400 Hz sine wave on the tape while spaces or logic zeros are represented by recording a 1200 Hz sine wave. With the proper circuitry this recorded data can then be read off the tape and converted into parallel data using a self clocking UART system which will tolerate audio recorder speed variations of approximately $\pm 30\%$. This figure is far better than that of most other modulation techniques and is a real advantage when you consider the degree of worst case speed variation between inexpensive audio recorders, in addition to which we have speed variations due to line voltage, battery voltage, wow and flutter, mechanism wear, etc. Thus evolved the "Kansas City" standard. It should be noted that the standard does not specify how the data is to be organized on the tape, so there can be, and probably will be some incompatibility among various manufacturer's software. This is a software problem which is fairly easy to resolve, given documentation of the data being sent.

Since the definition of the "Kansas City" standard, there have been several articles printed on circuits conforming to the standard, but there has yet to be a true audio cassette interface "system." When considering an audio cassette tape interface system, I think the potential user should ask the following questions:

1. Can the cassette interface be added to the computer system in such a way as to take full advantage of the computer system's existing resident tape load and dump routines?
2. Can the cassette unit be interfaced to the computer system without requiring the use of an additional interface port for the computer system?
3. Can the single cassette interface unit simultaneously or independently operate two audio cassette recorders (one reading while the other is recording) and if so can the user simply switch select the function of each recorder instead of swapping a multitude of patch cords?
4. Will the cassette interface provide manual or computer control (switch selectable) over either cassette recorder's motor operation in both read and record modes?
5. Does the interface have status indicators to show read and record states as well as valid data flow?
6. Can the cassette interface unit simultaneously operate with a computer or a 300 baud terminal, switch selectable, allowing you to use your terminal in a stand alone mode to record or visually examine data on tapes before loading them into your computer?
7. Can the unit be tied to a 300 baud terminal like the TV typewriter II so as to respond to reader on, reader off, record on and record off control commands just like a teletypewriter with automatic reader/punch features?
8. Is the cassette interface unit complete with chassis, cover and 120/240 VAC, 50 to 60 Hz internal power supply?

Well, these are the questions I asked when I set about to design the SWTPC AC-30 audio cassette interface. This article contains my answers to these questions as built into the AC-30. Although it has been designed for and used extensively with the SWTPC 6800 computer system and CT-1024 (TV typewriter II) terminal system, the AC-30 has been designed to be as universal and flexible a system as possible. If your computer's control terminal is interfaced to the computer through a 300 baud, RS-232 compatible serial interfaces with accessible clocks at 16 times the data rate on both computer and terminal, the SWTPC AC-30 cassette interface unit is simply plugged between the computer and terminal inter-

faces. This is the ideal mode of operation since the cassette unit can take full advantage of computer resident tape load and dump routines and requires no additional interfaces. Switching the cassette unit to the local mode directly interconnects the terminal and cassette unit for terminal "only" cassette tape operation just like the local mode of operation on teletypewriters. While operating in the remote mode, the computer communicates with both the terminal and cassette unit, here again just like the remote mode of operation on teletypewriters. Those individuals using the SWTPC CT-1024 terminal system or any terminal system with accessible control character decoders may even pick reader on (control Q), reader off (control S), record on (control R), and record off (control T) control commands right off the control character decoder circuitry on their terminal system, giving the computer system program control over cassette recorder data flow and

even motor operation. Those not having access to decoded control commands may still have cassette control by driving the cassette interface with control lines from a separate parallel interface option located on the attached computer system.

Those users not operating their control terminal RS-232 serial at 300 baud or not having access to their terminal's UART clock (at 16 times the data rate) may still use the cassette interface, but must attach it to the computer system through a separate RS-232 serial 300 baud interface with accessible clocks located in the computer system. This however eliminates the ability to use the computer resident control terminal tape load and dump routines as well as the local/remote feature described previously.

The cassette interface circuitry is constructed on a 7 3/4 by 7 1/2 inch (19.7 by 19.1 cm) double sided, plated through hole fiberglass circuit board with all electrical connections made to the board through one

Some Comments on the AC-30

by Carl Helmers, Editor

I purchased an AC-30 for my homebrew 6800 system when I stopped by at SWTPC for a visit following the ARRL national convention in Denver this past July. It took me two days (about 16 hours) on a weekend to put together this kit. My experiences confirmed Gary Liming's report in this issue. It was my first kit in recent memory; my last previous experience with kit assembly of electronics was a Heathkit "Benton Harbor Lunchbox" 2 meter amateur radio rig which I built with some help from experienced friends more than 10 years ago while in high school. The AC-30 went together at a "slow but steady" rate with the instructions serving as my guide.

I had a big psychological problem (from bad experiences with some earlier CMOS circuits) convincing myself to actually solder a CMOS integrated circuit into place. The argument which Gary Kay, Joe Deres and Dan Meyer at SWTPC give for using direct soldering of components has two major points: first, their firm uses only new integrated circuits which have a demonstrated low probability of failure if inserted correctly; second, a hard soldered connection is much less likely to suffer a mechanical problem than a socket. A corollary of the socket problem is the temptation of novices to use "any old socket" available inexpensively, which results in connection problems which multiply the possible sources of error. I saw a couple of beauties waiting in the SWTPC repair queue: kits which had been returned because "they don't work" according to their owners, but which had sockets which looked like refugees from a salt water bath. (The repair technique? Throw out the board, and rebuild using the formerly socketed integrated circuits!) So, in assembling my unit, I crossed my fingers, grounded myself and the soldering iron tip with clip leads, and took Gary Kay's persistent advice to solder the circuits in place. The result is seen in photo 2. The only problem I had in checking out the unit was a mischievous solder bridge (due to my own carelessness) that didn't look like a bridge at

Photo 2.



of the five edge connectors. The three connectors along the back edge of the circuit board are for connections to the computer, control decoder and terminal while the two along the front edge are for connections to the cassette interface's control panel. The printed circuit board in turn is mounted inside a 12 3/4 inch wide by 3 inch high by 11 inch deep (32 by 7.6 by 30 cm) aluminum chassis with a silver dress panel and black anodized perforated cover. The complement of front panel switches, indicators and jacks includes the following:

MIC, EAR and REMOTE jacks for recorder A: These jacks are connected through patch cords to the cassette recorder's respective jacks. It is often-times necessary to patch the MIC output of the cassette interface to the AUX input rather than the MIC input of the recorder. Some experimentation may be necessary here. Be sure the cassette recorder(s) you select have a

remote jack on them. This is necessary in order to have cassette recorder motor control, an essential part of convenient user software.

MIC, EAR and REMOTE jacks for recorder B: These jacks may be used for feeding a second cassette recorder, often required when using tape to tape software packages. Their functional description is identical to that provided for recorder A.

Record Select A or B: When this two position switch is in the A position, the cassette interface will output data to cassette recorder A. When in the B position it will output data to cassette recorder B.

Read Select A or B: When this two position switch is in the A position, the cassette interface will read data from cassette recorder A. When in the

all. Photo 3 shows the rear of the front panel in the unit I assembled.

Extending the AC-30's Usefulness

While I have not tried the following suggestion yet, in preparing this article on the AC-30 the following thought occurred: The circuit of figure 1 does not care if the UART is really running at 16 times the clock rate. By eliminating the redundancy of the "Kansas City" standard, and generating one's own signals with a programmed data formatting routine, it should be possible to use the AC-30 through a PIA port and RS-232 level shifters to run at 2400 baud. [Authors take note: Details of such a program to modify the AC-30's normal usage mode would make an excellent article.] If parallel IO and computation is required, multiprogramming using the processor's interrupt structure would be required, with the addition of an output clock generator to keep track of real time without programmed loops. (Input would drive an interrupt line directly from the clock extracted off the tape by the AC-30.)

Some Design Ruminations

In a preliminary calculation assuming for example my 6800 system with its current 833 kHz clock, the 4800 Hz data clock rate allows about 174 processor cycles for each clock period of the IO operation. Of these

cycles, at least 22 are required for the fixed overhead of a 6800 interrupt, whether or not the interrupt does anything (12 cycles to get to the interrupt handler, 10 to return). Assuming that this is the only active interrupt, the input or output data handler for each bit could conservatively be expected to take less than 100 additional cycles (20 to 30 instructions or so). Thus with an interrupt driven programmed interface, I might expect about 70% of real time to be occupied by IO during read or write operations as a reasonable worst case prediction of processor utilization. A similar calculation could be done for the 8080, TMS9900, or other microprocessors with which the AC-30 could be used in this mode of operation. ■

Photo 3.

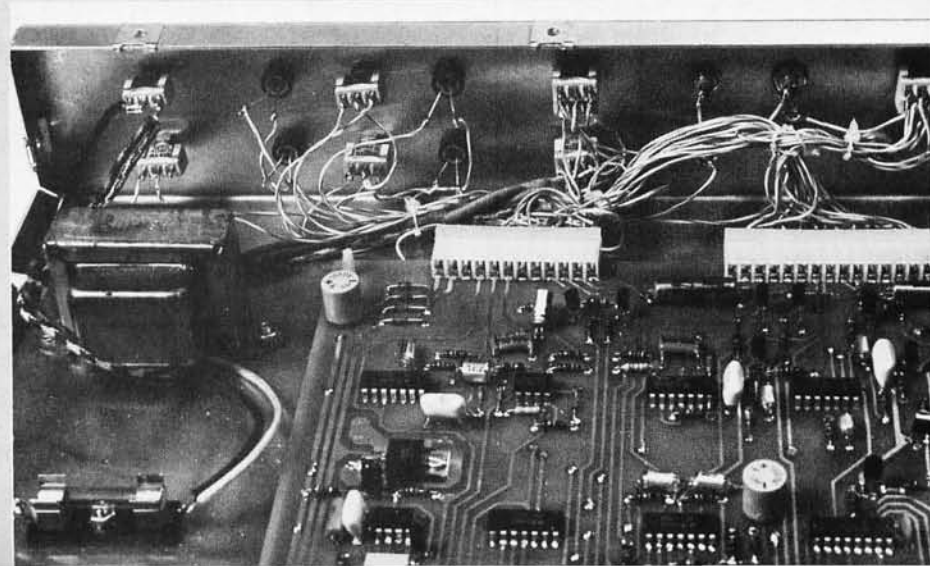
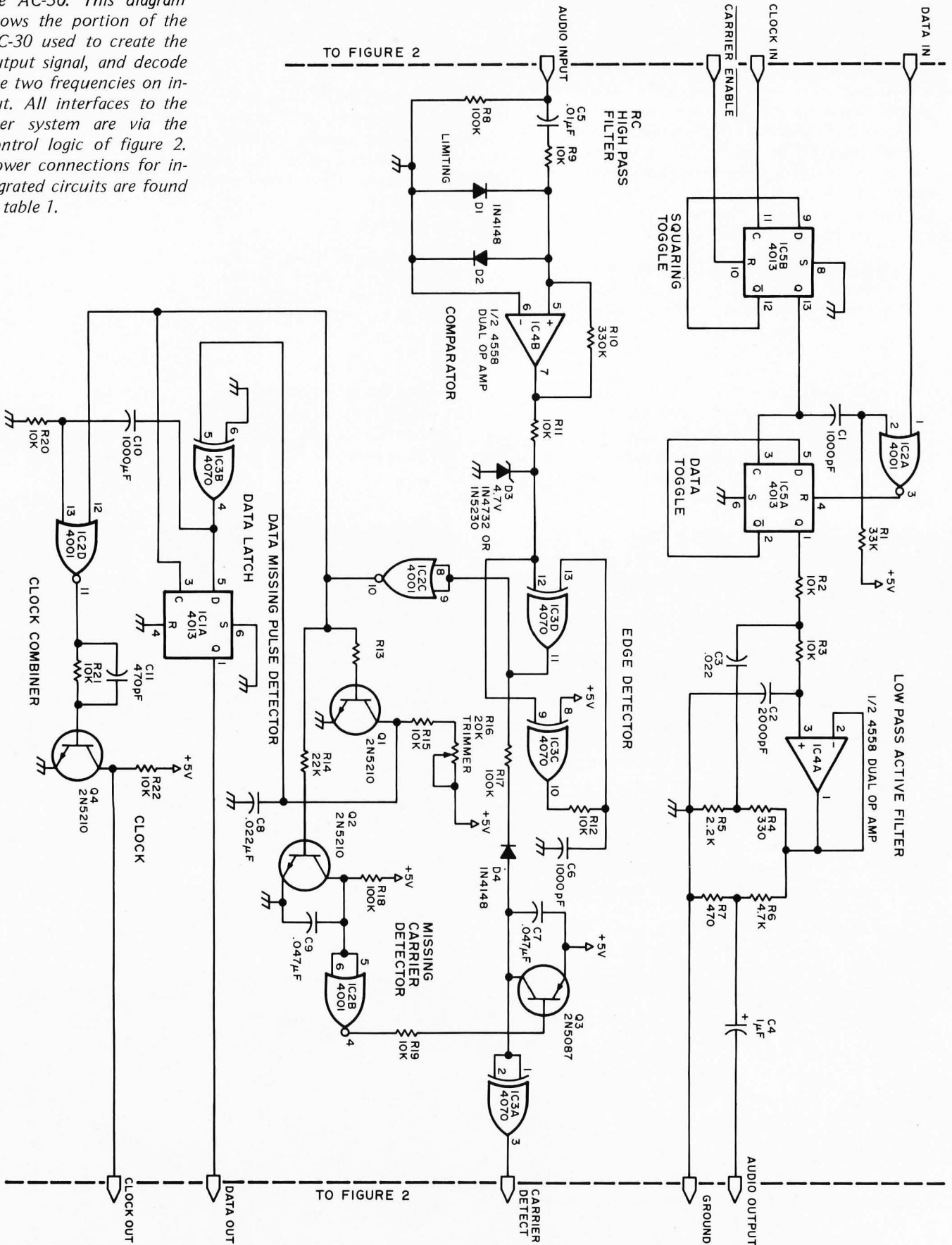

Figure 1: Modulator and Demodulator Circuitry of the AC-30. This diagram shows the portion of the AC-30 used to create the output signal, and decode the two frequencies on input. All interfaces to the user system are via the control logic of figure 2. Power connections for integrated circuits are found in table 1.



B position it will read data from cassette recorder B.

Record Status On or Off: This three position switch is normally left in the center position allowing computer program generated control commands to set the state of the record latch. Momentarily flipping the switch to the ON or OFF position will manually update the status of the record latch. Leaving the switch in either the on or off position will override computer program control entirely. An LED status indicator just to the left of this switch always shows the state of the record latch. The operation of the cassette interface as a function of the state of the record latch is dependent upon the setting of the motor control switch which is described in detail later.

Read Status On or Off: This three position switch is normally left in the center position allowing computer program generated control commands to set the state of the read latch. Momentarily flipping the switch to the on or off position will manually update the status of the read latch. Leaving the switch in either the on or off position will override computer program control entirely. An LED status indicator just to the left of the switch always shows the state of the read latch. The operation of the cassette interface as a function of the state of the read latch is dependent upon the setting of the motor control switch which is described in detail later.

Record Data Indicator: This LED indicator shows the transmission of valid data out of the cassette interface. It lights only when the record latch is on and logic zeros or spaces are being transmitted. This allows the operator to confirm that a tape dump is in progress when lit, since the null data marking output does not light the indicator.

Read Data Indicator: This LED indicator shows the receipt of valid data into the cassette interface. It lights only when the read latch is on, valid FSK data is detected on the tape, and logic zeros or spaces are being received. This allows the operator to confirm that a tape load is in progress when lit, since the null data marking input or a loss of audio tones does not light the indicator.

Motor Control — Manual or Automatic: The position of the motor control switch actually determines the function of the record and read status latches. In the manual position both the cassette recorder motors are always activated through their respective remote jacks. If the record latch is off, the interface's selected recorder MIC jack will always output a constant marking carrier, even if there is data flowing back and forth between the computer and terminal. As soon as the record latch is turned on, either by the computer or manual control, all data transmitted from the computer to the terminal is simultaneously transmitted out through this same MIC jack. Data flow out of the MIC jack ceases as soon as the record latch is again reset by either manual or computer control.

If the read latch is off, the interface will ignore all data incoming through its selected EAR jack and yet pass data back and forth between the terminal and computer. If the read latch is turned on either by manual or computer control and valid audio tones are sensed from the selected EAR jack, read data is stored from the cassette unit to the computer. This same data is simultaneously displayed on the attached terminal system only if the computer is programmed to echo the incoming cassette data. Data flow from the cassette to the computer system ceases either upon resetting the read latch or loss of audio tones on the tape.

Operation in the automatic position is quite different. If both the record and read latches are reset, cassette recorder motor operation is inhibited through the respective remote jacks on both the recorders. The interface's selected record MIC jack will output no audio data, even if there is data flowing back and forth between the computer and terminal. As soon as the record latch is turned on, the recording recorder's motor is turned on through the respective remote jack and a variable delay timer is fired which delays the output of audio marking data to allow this same cassette recorder's tape to come up to normal tape speed. This hardware delay circuit must be supplemented with a software delay loop written into your programs to guarantee that you don't start outputting record data until after this hardware delay timer on the cassette

Figure 2: Control Logic of the AC-30. This diagram shows the computer and terminal interfaces of the AC-30.

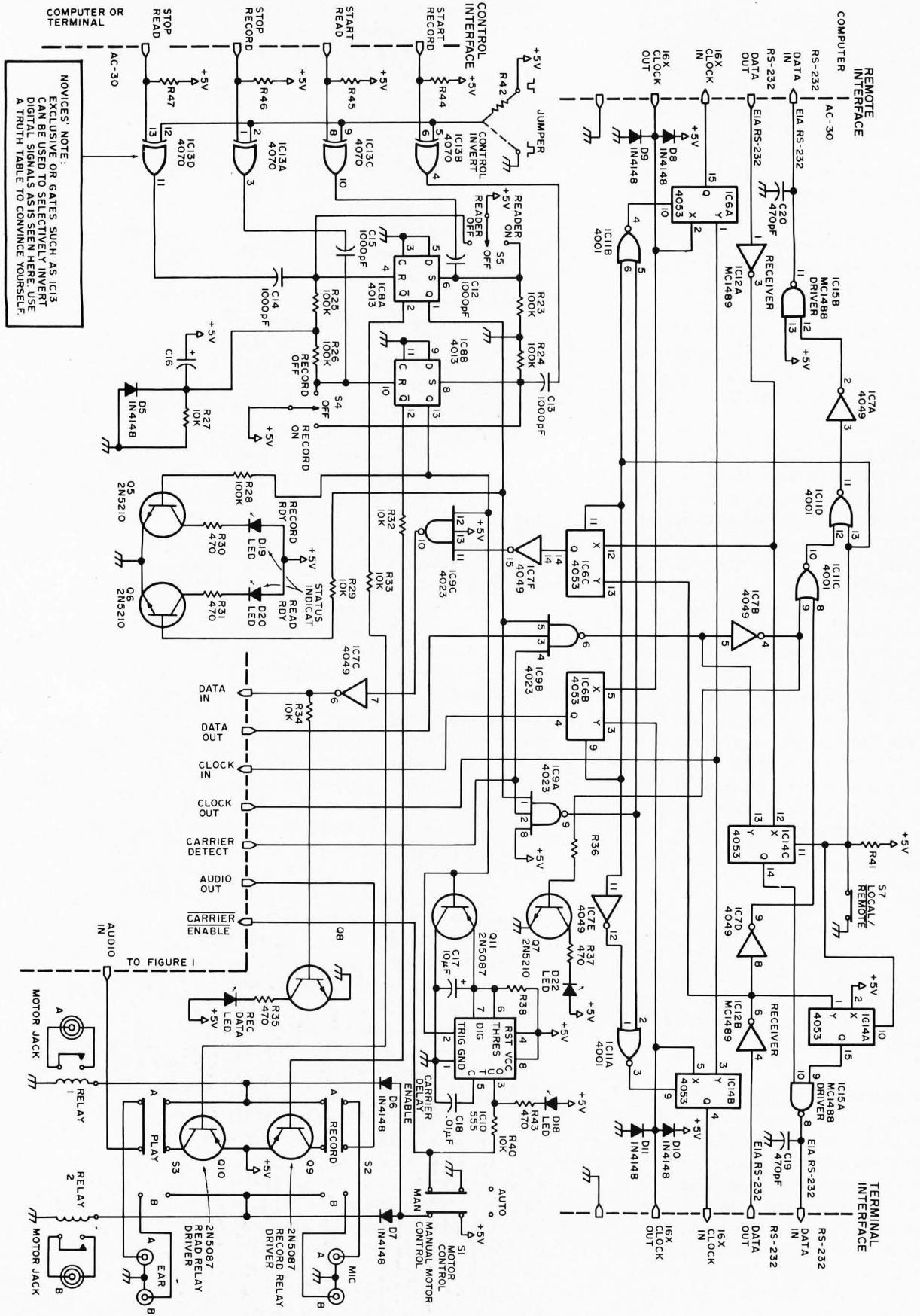

interface has already timed out. When the record latch is again turned off, the interface will cease to output audio data and the selected recorder's motor is turned off. Here again it is wise to include a software delay loop in your programs to give the recorder time to come to a complete stop. This guarantees a sufficient gap between multiple recorded segments to allow one to do either incremental (start-stop) or continuous reads from the same tape.

When the read latch is turned on, the read recorder's motor is started. The interface inhibits all read recorder data until valid audio tones are detected, at which time all incoming cassette data is stored in the computer and simultaneously displayed on the terminal only if the computer's echo is enabled. Reads may be either continuous or incremental (start-stop). Since incremental tapes have blank gaps between recorded segments, the cassette interface's audio tone sensing circuitry has been designed to ignore all but the valid data segments stored on the tape.

Local/Remote switch: The local/remote switch on this cassette interface is analogous to that on standard teletypewriters. In the local mode there is a direct data link between the terminal and cassette recorder(s). The computer is electrically eliminated from the system. In the remote or normal mode of operation, the computer, terminal and cassette recorder(s) are all linked together.

Power On/Off: This switch controls AC power to the cassette interface unit. It must be powered up consistently with the interconnected computer and terminal systems even if cassette operation is not desired.

Attaching the Interface to the Recorders

If you will be using the interface just for loading and storing programs and data files to and from tape, you will probably need just one cassette recorder. If, however, you will be doing tape file editing or using assembler packages, you will probably have to use two cassette recorders. The same interface will handle both configurations. Electrical connections between the cassette interface and recorders are best made by cutting several 3 to 4 foot (90 to 122 cm) audio patch cords with the

molded RCA connectors on both ends, in half, and fitting the newly cut ends with the appropriate recorder jack mating connectors. Some cassette recorders such as the ones used with the prototype have both high level auxiliary and low level microphone inputs. In our case it was necessary to use the auxiliary input since the cassette recorder circuitry would not permit the reading of a tape with a plug simultaneously installed in the microphone jack. Be sure to use a cassette recorder featuring an AGC (automatic gain control) circuit. Most late model cassette recorders have this feature. Since cassette motor control is available, you will want a recorder with a remote jack that stops the recorder's motor. Here again recorder circuitry varies. Some units disable just the motor while others disable everything. It is best in this instance to just disable the motor. This will minimize the recorded transients between blocks of data when using the interface in the incremental (start-stop) mode of recording. The recorders used with the prototype were Superscope brand model C-101A [Superscope is a registered trademark of Superscope Inc.]. Although they were reliable, close examination of the quality of recorded data with an oscilloscope left a lot to be desired. The optimum volume control setting was around 7 on a scale of 0 to 10.

The quality of the cassette tape used with your recorder(s) will also affect the reliability of your system. Here the best rule of thumb is to assume you get what you pay for. The more expensive tapes will generally give better reliability. Remember too that you are recording audio frequency data, not saturated pulses. So don't use digital computer grade cassette tapes. Always erase previously recorded tapes with a bulk tape eraser such as a Radio Shack No. 44-210 (\$9.95) before rerecording them. This is especially important when using the system in the incremental (start-stop) mode of operation. Bulk tape erasers generally do a better job of erasing than a recorder's internal circuitry and guarantee that you don't pick up segments of previously recorded programs or data.

The interface's read circuitry must be calibrated for use in the read mode before using the interface. This is best done by first generating a calibration tape with continuous ASCII fives recorded on it and then reading back the tape to the terminal in the local mode while adjusting trimmer resistor R16 for a center setting between errored reads. ASCII fives have an alternating bit sequence ideal for calibration. It is a good idea to periodically recheck this setting using

your previously generated calibration tape.

Before using your cassette interface unit in the incremental (start-stop) mode of recording, it will be necessary to set the time delay on the carrier enable oneshot, trimmer resistor R39, so as to allow the recorder's motors to come up to speed before outputting a marking audio tone. This is best done by visually measuring your recorder's motor start time and then multiplying by two just for a safety factor. The interface's delay is then set by adjusting trimmer resistor R39 for this same time delay between the time the record "ready" indicator lights and the carrier enabled indicator (LED diode D18) comes on. The latter is mounted right on the interface's printed circuit board adjacent trimmer resistor R39.

Whenever you are writing to tape in the incremental mode you must provide a software delay loop in your program that is at least as long as the adjustable hardware timer delay plus 0.5 seconds. The additional half second is required to guarantee a carrier detect signal before data flow when the tape is being read. It is also a good idea to put a header character or characters ("synchronization" characters) at the beginning of each incremental record. Upon reading these records, your program should be written such that it ignores all data between these recorded segments until this header data is read. The cassette interface is more vulnerable to error reads between incrementally recorded data than at any other time. The end of each data block may easily be detected by recording some nondisplayed control character, or your software could include a block data count in its header. If you are using the cassette interface with the SWTPC 6800 computer system and CT-1024 (TV typewriter II) terminal system, the decoded record off ASCII control T command (hexadecimal 14) not only turns the recorder off, but is written at the end of the data record as well, for an end of record character.

Incrementally recorded records may be read either continuously or incrementally. In either case you must provide a software delay in your program at least one character time (33 ms) between the time the end of record character is read and the time data is output from the interface. The reason is that there is a slight delay between the loss of carrier on the tape and action of the carrier detect circuitry which in turn creates a gap in the 16 X UART clock. This gap causes no problems so long as you are not outputting data during the clock gap; thus the reason for the delay.

Fortunately consideration of tape gaps is

only necessary when using the interface in the incremental mode. Operating the system in the continuous mode isn't much different from paper tape operation. You will of course have to manually start and stop the recorders; but no special recording considerations are necessary, which usually allows use of unmodified computer resident tape load and dump routines for limited program storing and loading in a paper tape emulation mode.

Let's assume now we have a SWTPC 6800 computer and CT-1024 terminal system interfaced together with 300 baud RS-232 serial interfaces. As mentioned earlier for this configuration, the cassette interface can be connected in series between the two, taking full advantage of the computer's Motorola MIKBUG firmware tape dump and load routines. Let's also assume we have a program we wish to dump to tape which is already stored in the computer's memory with the computer's program counter, storage addresses (A048 and A049), set to the starting location of the program. Now use the memory change function to set the starting and ending addresses of the memory segment to be dumped in locations A002 through A005. The cassette interface's switches should be set for manual motor control with the record/read status switches in the center position and the local/remote switch in the remote position. Load a blank or previously erased tape into the selected cassette recorder and depress the rewind button to get to the beginning of the tape. Then depress the play button to advance several seconds beyond the leader on the tape. Stop the recorder and this time depress the cassette recorder record button. Then enter a P for punch on the terminal's keyboard. MIKBUG will interpret the P and then the record status light will come on, and the record data light will flicker as program data is stored to the cassette tape. When the dump is completed, both the status and data lights will go out. Do not stop the recorder; instead set memory locations A002 through A005 to dump the data stored in the program counter storage addresses as well. Since the record status light is not lit, none of this data passing back and forth between the terminal and computer is written to the still operating recorder. Again enter a P for punch. The status and data lights will again come on, but only for a fraction of a second since only two memory locations are written to the tape. Now while the cassette recorder is still recording, flip the local/remote switch to the local position, use the manual record status switch to set the record status latch and type in on the

The audio cassette interface described in this article is manufactured by Southwest Technical Products Corp, 219 W Rhapsody, San Antonio TX 78216. It is sold in kit form only, No. AC-30 for \$79.50, postpaid in the US. The kit includes circuit board, components, chassis, cover, power supply and assembly instructions but does not include the cassette recorders.

Figure 3: The power supply for the AC-30; see table 1 for wiring. Raw supplies of +13 V and -13 V are used by the EIA line drivers; zener regulated +7.5 and -7.5 are used by modem operational amplifiers; CMOS logic uses the +5 V supply.

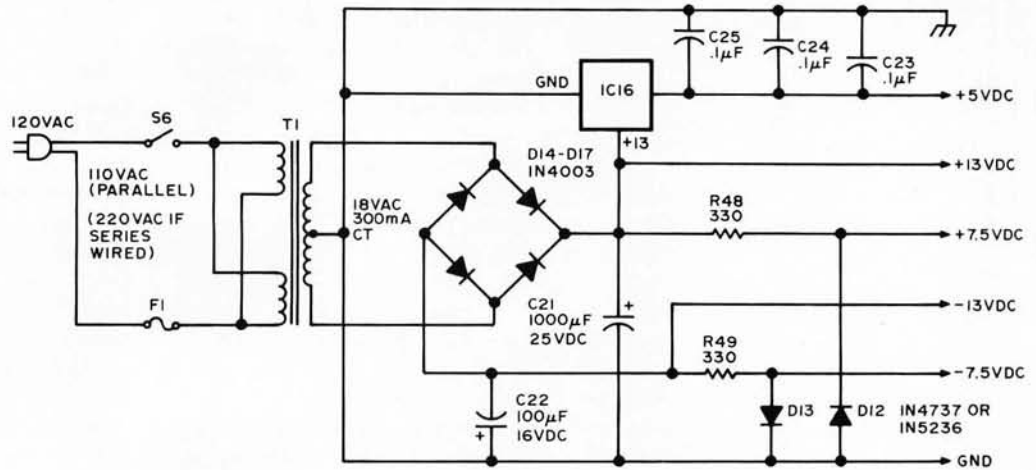

terminal's keyboard S9 (the MIKBUG end of program code). Now you may stop the recorder. Don't forget to flip the local/remote switch back to the normal remote position.

Before trying to load this same program you might want to momentarily turn the computer off just to make sure the memory resident program is destroyed before loading. Reapplying power will force an auto-reset and start up the resident Motorola MIKBUG firmware on the SWTPC 6800. Rewind the tape to the beginning, making sure the cassette recorder's volume is set to a reliable setting, and depress the play button. Then type in a L for load on the terminal's keyboard. The read status light will immediately come on since the firmware outputs a read on control command. The data light however will remain off until program data is detected on the tape at which time it will begin to flicker. When it stops flickering it means that the program data has been loaded to the computer's memory but don't forget that the program counter data was also written to the tape, so the next flicker is that of the program counter being loaded. An S9 was also written to the tape; it is an end of tape marker. Upon reading this, the computer will output a read off control command forcing the read status light to go out, hence ignoring all subsequent data stored on the tape should the recorder be left to run. The program as well as the program counter have been loaded. Simply typing in the character G for go should initiate the program.

How It Works

For simplicity the cassette interface's circuitry has been broken up into three

separate systems: The modulator demodulator circuitry, the switching circuitry and the power supply. These are shown in figures 1, 2 and 3, respectively.

The modulator works by feeding a 4800 Hz (16 times 300 Hz) clock into the toggle provided by IC5b. The division by 2 in this flip flop insures a 50% duty cycle required by the modulator. The carrier enable input provides a means of suppressing audio output from the modulator. IC5a divides the frequency by two once more if the data in line is high and simply follows the clock frequency if the data in line is low. This gives a 1200 Hz tone for a low state and a 2400 Hz tone for a high state. The resulting output is then fed into two pole active filters provided by the 4558 operational amplifier section IC4a, where it is converted to a closer approximation of a sinusoidal audio waveform which is more easily handled by audio recorders.

Incoming audio data is first fed into a high pass filter consisting of R5 and C5 and then onto comparator IC4b. The compar-

Table 1: Integrated Circuit Power List. The supplies are taken from the circuitry in figure 3, and wired to the appropriate pins of these circuits.

Number	Type	+5 V	GND	+7.5 V	-7.5 V	+13 V	-13 V
IC1	4013	14	7	—	—	—	—
IC2	4001	14	7	—	—	—	—
IC3	4070	14	7	—	—	—	—
IC4	4558	—	—	8	4	—	—
IC5	4013	14	7	—	—	—	—
IC6	4053	16	8	—	—	—	—
IC7	4049	16	8	—	—	—	—
IC8	4013	14	7	—	—	—	—
IC9	4023	14	1	—	—	—	—
IC10	555	8,4	1	—	—	—	—
IC11	4001	14	7	—	—	—	—
IC12	1489	14	7	—	—	—	—
IC13	4070	14	7	—	—	—	—
IC14	4053	16	8	—	—	—	—
IC15	1488	—	7	—	—	14	1

tor's 0.5 V hysteresis reduces the possibility of false triggering. The ± 7.5 V zener regulated power buses feeding IC4 are necessary to stabilize this hysteresis value. Zener diode clamp D3 limits the comparator output to CMOS compatible voltage levels. Each time the comparator changes states the exclusive OR functions of IC3c and IC3d generate a 5 μ s active low pulse at IC3 pin 11. This pulse is repetitive when data is being received and pulls capacitor C7 down to ground through diode D4. The level on capacitor C7 is in turn inverted and buffered through IC3a to form the carrier detect signal. This same active low pulse is inverted by IC2a where it feeds four separate circuits. The first is a missing pulse detector composed of transistor Q2 and inverter IC2b. This forces the buffered carrier detect signal low whenever several cycles of audio carrier are missed. The second circuit is also an adjustable missing pulse detector but this one times out whenever 1200 Hz data is being fed into the demodulator. The 20 k ohm trimmer resistor R16 sets the period for this timer. The third circuit driven by this pulse is the clock input to flip flop 4013 IC1a which outputs the demodulated data. This data out line is high when 1200 Hz audio is being demodulated and low when 2400 Hz audio is being demodu-

lated. The fourth circuit fed by the pulse is IC2d which with the addition of the output of IC3b synthesizes the 16 X clock out data. Take note that although on the average this clock is accurate, it jitters by design.

Within the control portion of the circuit, figure 2, integrated circuit halves IC8a and IC8b form status latches for the record and read circuitry. Either latch may be independently set or reset through manual toggle switches on the interface's front panel or through control pulses buffered and selectively inverted by IC13. Front panel LED indicators always show the current status of these latches.

The multitude of data and clock switching is performed by six data selectors within IC6 and IC14. NAND gates IC9a and IC9b inhibit data and clock flow out to the cassette recorders unless the read latch is set and valid recorder carrier data is detected. Timer IC10 provides the adjustable $\overline{\text{CARRIER ENABLE}}$ delay needed when using the system for recording in the incremental mode. All 300 baud data communication with the cassette interface is done through integrated EIA RS-232 receiver and transmitter integrated circuits IC12 and IC15 respectively. Motor control for each recorder is provided by reed relays RLY1 and RLY2. ■

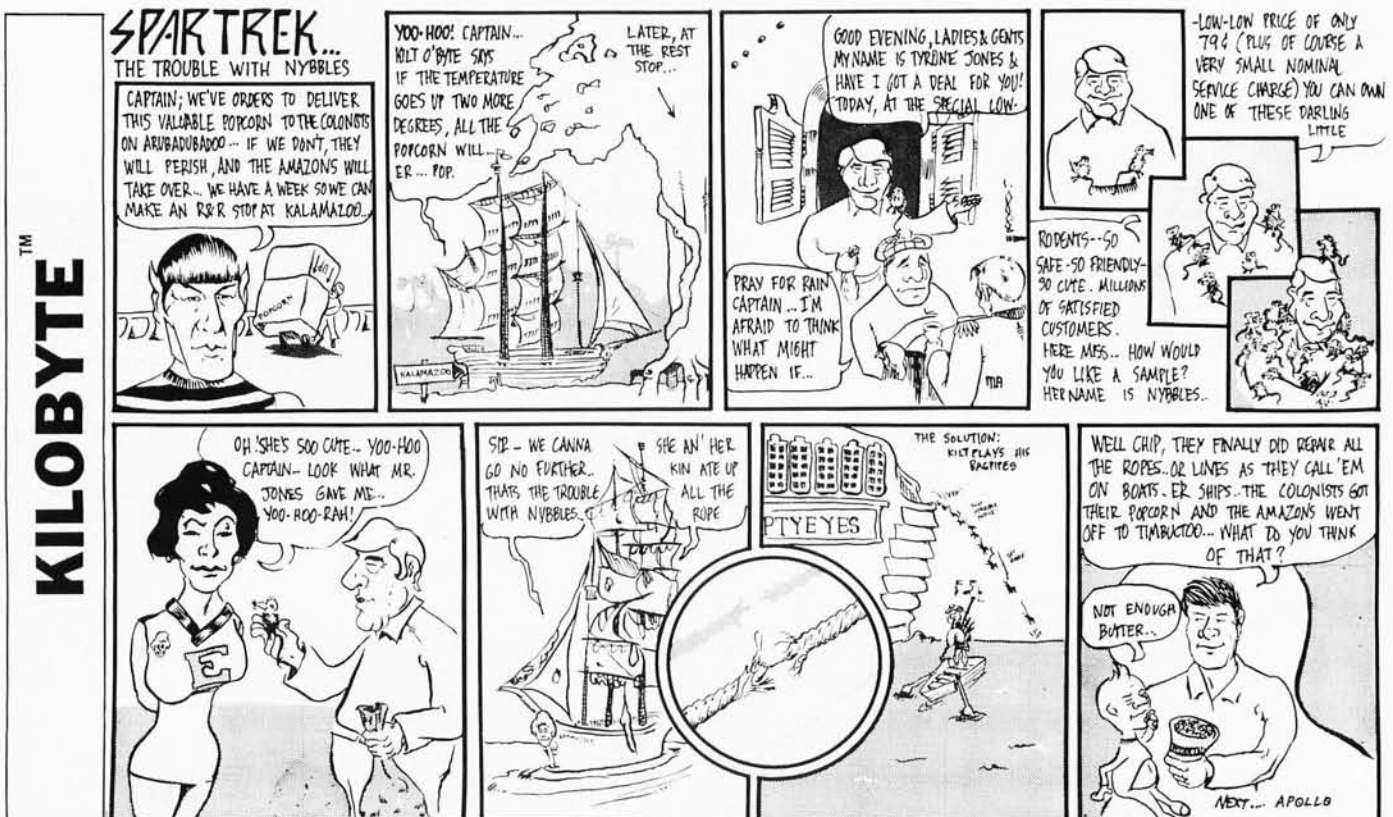

SEX

Now what self-respecting company resorts to a cheap trick like this to get your attention.

WE DO

And it works, doesn't it? So does our new 16K STATIC RAM memory board. It is fully assembled and tested and plugs into your SWTPC 6800 microcomputer—allowing you to expand your system to 48K. The PRICE?? That's the sexy part. It's so BARE we can only reveal it through the mail. (Sent in plain brown wrapper so as not to offend a non-computer oriented spouse.)

Name _____

Street _____

City _____

State & Zip _____

SMOKE SIGNAL BROADCASTING
P.O. Box 2017
Hollywood, California 90028



*Arizona
Micro Systems*

IMSAI Dealer

* **Systems from \$540**

* **CRT Kit ADM-3 \$849**

* **RAM 4A-4 \$125**

**3240 W LARKSPUR
PHOENIX AZ 84021
(602) 942-8405**

*Computer Mart
New York*

LONG ISLAND

Christmas gift certificates available

IMSAI, SWTPCo, Digital Group
Processor Tech, Apple, OSI
TDL-Z-80, Seals, Cromemco,
Veras, Tarbell, Oliver

Magazines, books, chips,
sockets, connectors, terminals.

**IT'S ALL HERE WAITING FOR YOU
FRIENDLY ADVICE TOO**

New York City

314 5th Ave.

(32nd St)

New York 10001

212-279-1048

Long Island

2072 Front St

East Meadow NY

516-794-0510

\$100 OFF IMSAI

The Bits, Bytes & Pieces Computer Store is having a sale to celebrate the grand opening of their mail order operation in the Sacramento area. We feature the complete IMSAI micro computer and peripherals line & our standard price will be 10% off the list price for IMSAI computer kits, board kits and peripherals. However, our sale prices will be 15% off! computer & board kits. For example the \$599.00 basic 8080 will be only \$499.00. Group purchase prices are available. This offer expires December 31, 1976. Write us for details and catalogue.

Bits, Bytes & Pieces
6211 Quincewood Circle
Citrus Heights, CA 95610
(916) 726-6469

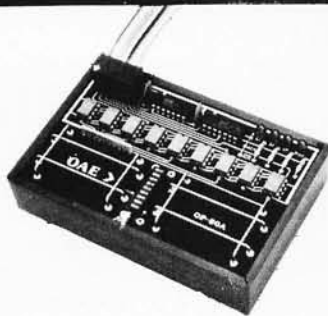

Pictured above is the new OP-80A High Speed Paper Tape Reader from OAE. This unit has no moving parts, will read punched tape as fast as you can pull it through (0-5,000 c.p.s.), and costs only \$74.50 KIT, \$95.00 ASSEMBLED & TESTED. It includes a precision optical sensor array, high speed data buffers, and all required handshake logic to interface with any uP parallel I/O port.

To order, send check or money order (include \$2.50 shipping/handling) to Oliver Audio Engineering, 7330 Laurel Canyon Blvd., No. Hollywood, CA 91605, or call our 24 hr. M/C-B/A order line: (213) 874-6463.

MODULES FOR ALTAIR AND IMSAI COMPUTERS

8K STATIC MEMORY — KIT \$295

ASSEMBLED \$375

16K STATIC MEMORY — KIT \$650

ASSEMBLED \$775

WIRE WRAP BOARD — KIT \$ 39

EXTENDER BOARD W/C — \$ 30

BATTERY BACK-UP BOARD

LESS BATTERIES — KIT \$ 55

115V I/O BOARD — KIT \$ 149

ASSEMBLED \$200

THE 115V I/O BOARD HAS FOUR INPUTS AND FOUR OUTPUTS EACH 115VAC AT 1.5 AMPS. NO LONGER A NEED FOR RELAYS WITH THIS BOARD.

To order send check or money order (include \$2.50 shipping/handling) to ELECTRONIC ENG. & PRODUCTION SERVICES, Rt. # 2, Louisville, Tennessee. (Tn. users add 6% sales tax) (615)984-9640

Building the AC-30

Cassette Interface

Gary Liming
3152 Santiago Dr
Florissant MO 63033

Any hobbyist who has ever loaded a sizeable program on a bit by bit or byte by byte basis, only to have it wiped out when the power is removed, really understands the significance of mass storage. Cassette recorders are attractive mass storage devices to a hobbyist because they are inexpensive and can be interfaced easily.

Southwest Technical Products Corp (219 W Rhapsody, San Antonio TX 78216) introduced their answer to mass storage with the AC-30 cassette interface in May 1976. [See Gary Kay's article in this issue.] At that time I had a 6800 processor using Motorola's MIKBUG as a monitor ROM and a CT-1024 with keyboard. While reading the advertisement brochure I was struck with fact that the interface made use of an already existing standard, the RS-232 interface. If I decided to try a different system later on, I would be able to keep the interface and tapes and use an easily acquired RS-232 connection on the new system. It also provided for two cassette drives for future system expansion. Seeing no problems connecting the AC-30 to my system, I ordered the AC-30 by phone for \$79.50 postpaid, and received it by UPS two weeks and two days later.

When the kit arrived, I immediately started studying the documentation. As I was reading, the directions mentioned a calibration program that should have been

supplied but was not included. I finished reading the instructions, made sure the parts were all there, and called SWTPC.

I spoke with an engineer who confirmed the missing page, and took my name and address. Only two days later a complete set of documentation appeared in my mailbox. The two days were not wasted, however, because it took me nearly that long to clear off a space on my workbench to build it!

The documentation package consisted of 22 pages of assembly instructions, complete schematics, a parts list, and a two color printed circuit board component layout. Included are two 17 3/4 inch by 22 1/2 inch (45 cm by 57 cm) charts showing wiring connections inside the AC-30 and between the terminal and computer system. Also, 11 pages of diagnostic and calibration software written for a 6800 system are included.

Assembly began with the 7 3/4 inch by 7 1/2 inch (19.7 cm by 19.1 cm) printed circuit board that I inspected, found no faults with, and which generally looked like a high quality board. Instructions for the kit are at a level of "Place all of the resistors on the board using the parts list and component layout drawing . . .", so you must at least know resistor color coding and be able to identify the parts. Using reference charts from electronics "how to do it" books will help to prevent mistakes for the novice.

Placing and soldering the 39 resistors, 25 capacitors, 16 integrated circuits and 11 transistors was time consuming, but not difficult. The soldering pads are placed well apart from each other, making soldering

easier than on some memory or processor boards. Solder is included.

Although there is a controversy among manufacturers, hobbyists, and engineers over the use of sockets, I decided to use them. Kit manufacturers don't advise sockets because they make a returned board very difficult to repair if the fault is due to a socket. A bad solder flow under the socket is hard to detect without tearing out the socket. Hobbyists sometimes get low quality sockets which can cause intermittent problems that are nightmares to debug.

I used quality sockets and verification soldering techniques because they help reduce integrated circuit handling (almost all of the integrated circuits in the kit are CMOS) and mainly because I would be doing my own repair work in the future. However, if you do not intend to repair your own equipment, there is little benefit in using sockets in a kit.

After completion of the printed circuit board, chassis assembly began. The 12 3/4 by 11 by 3 inch (32 cm by 30 cm by 7.6 cm) aluminum chassis holds the printed circuit board, transformer, fuse, and a dress front panel. A perforated black finish aluminum cover and rubber feet are included. All wiring to the printed circuit board is made through connectors which make removal of the board simple. The large connection charts are very helpful, and wire and wire ties are provided. Before starting chassis assembly, a little forethought about the routing of wire between the switches, phono jacks, LEDs, and printed circuit board connectors will help to save mistakes.

Front panel assembly went smoothly except for snapping the LED retainer clips into place. I found that using two ballpoint pen halves to push the clips together saved wear and tear on my fingernails.

Interconnecting cables between the terminal and computer are routed through a grommet directly to the printed circuit board connectors. In addition to the front panel switches, control inputs are provided for remote or computer control of the reader on, reader off, record on, record off, and Local/Remote modes. If you are using the CT-1024, these inputs can be controlled by using the CT-CA (computer controlled cursor board) which decodes various ASCII control characters that appear on the RS-232 interface. Otherwise, the controls can be operated via computer commands by building a decoder for the control characters or by dedicating a separate output port or address space for these functions. The interface requires both the terminal and computer to provide a X16 clock.

When assembly was completed, I bought cassette connecting cables (not supplied) and, like most recorders, mine required two miniature to phono and one subminiature to phono cables. I am using a Sankyo ST-50 recorder, picked out solely because it was the most inexpensive (\$44.95) recorder I could find that had automatic level control, auxiliary and remote inputs, and a tape counter. The tape counter is not necessary, but does allow you to easily catalog a number of programs on a single tape.

After connecting the recorder, two calibration steps are required. One is used to set the time between when the record on signal is received and when the record carrier comes up. This is necessary to allow the cassette motor to come up to speed before the recording begins, and is noncritical. The easiest way to adjust the delay is to visually inspect the start up time of the cassette motor, and set the delay greater than that. An on board LED is provided to indicate the carrier enable signal, and the adjustment is made with an on board pot and 555 timer.

The other adjustment is made to set the character frequency of the reader circuitry, and is done by loading the calibration program. This program outputs a control character to turn the recorder on, an ASCII five (chosen because of its alternating bit pattern), and a recorder off character, all in a continuous loop. After recording a tape of fives, the tape is then read back in local mode to the terminal. The calibration pot is then adjusted to center between the points at which errors occur. I found this to be a very wide range in which the reader would operate with no errors. This program is also useful in verifying new tapes for data use. A little experimentation showed that the best volume setting was about 7 on a scale of 0-10. The tone control seemed to make little difference except at extreme settings.

Now that calibration was completed, I loaded a program byte by byte for the last time, and dumped it out to my first mass storage peripheral! The program was approximately 2 K bytes and took 3 1/2 minutes to load back into the system. This is longer than 30 cps would account for, but is due to the Motorola MIKBUG dump and load routines that output two characters per byte (hexadecimal) and includes some error checking and addressing overhead.

The recording method is compatible with the "Kansas City" standard, and I have successfully read tapes generated by the "Bit Boffer" interface as described in the March 1976 issue of BYTE [page 30]. If there are any other 6800s with MIKBUG listening out there, drop me a card and let's swap! ■

BITS™ Presents:



____ **TV Typewriter Cookbook** by Don Lancaster. A complete guide to low cost television display of alphanumeric data, several chapters of which were published ahead of the book in early issues of BYTE magazine. \$9.95

____ **Digital Logic Circuits** by Sol Libes. An invaluable tutorial background volume on digital logic, arithmetic, IO concepts and interfacing to analog devices; written by one of the founders of the Amateur Computer Group of NJ. This book acquaints the reader with much of the terminology and background concepts of digital hardware. \$5.98.

____ **Modern Operational Circuit Design** by John L. Smith. An absolutely essential introduction to the use and application of operational amplifier systems. The book contains both theoretical background information and practical circuit suggestions which can be used to advantage by the experimenter. \$16.95 (hardbound).

____ **Electronic Projects for Musicians** by Craig Anderson. "Even if you know nothing about electronics, you can build preamps, ring modulators, mixers, tone controls, miniamps, fuzzes and a dozen other inexpensive musical projects." Furthermore, even if you couldn't care less about musical applications, you can use this book to gain familiarity with electronic parts, circuit diagrams and construction techniques, using the wealth of illustrations and tips found in an extended introductory chapter for the novice electronicist. \$6.95.

____ **Active Filter Cookbook** by Don Lancaster. The chief chef of electronics Cookbooks concocts another gourmet appetizer. Run to this book when you need to find a starting point for the design of a filter for use in an electronic application. \$14.95.

____ **Altair Design** developed by Ensor Holiday.

____ **More Altair Design** developed by Ensor Holiday.

____ **Altair Design 3** developed by Ensor Holiday.

Keep the loved ones busy while you use your system . . . give them any one or all of these computer generated **Altair Design** books to start them (or yourself) on endless hours of creative coloring. No other coloring books are quite like these unique books. \$2.50 each.

____ **Artist and Computer** edited by Ruth Leavit. A visual treat, as you encounter reproductions of numerous works by computer oriented artists and read about these works in their own words. \$4.95.

____ **Linear IC Principles, Experiments, and Projects** by Edward M. Noll. From basic principles to complicated systems, from simple amplifier experiments to applications in radio, TV and control systems, this book can improve your knowledge of the way circuitry of the analog world really works. \$8.95.

____ **Practical Solid-State Circuit Design** by Jerome E. Oleksy. A self study course in the design of semiconductor circuits from the simple transistor to the complex operational amplifier. \$5.95.

____ **Boolean Algebra** by Brice Ward. A background tutorial and study guide for the design and simplification of static networks of logic gates. Learn how to combine those ANDs, NANDs, NORs and ORs to evaluate complicated logical conditions of multiple inputs, electronically. \$5.50.

____ **Projects in Sight, Sound & Sensation** by Mitchell Waite. Dedicated "to all space cowboys." Detailed theory and practice of seven fascinating amateur electronics projects, along with a complete and detailed appendix on how to make PC boards. \$4.95.

____ **Creativity, Invention, & Process** by John A. Kuecken. Practical philosophy and history for the inventor. \$3.50.

____ **Inventors Projects Book** by L. George Lawrence. 120 well thought out problems which can serve as a starting point for the creative inventor. All are essentially unsolved by contemporary technology, and all are highly recommended reading for the creative mind. \$4.50.

____ **Security Electronics** by John E. Cunningham. To catch a thief, apply liberal doses of ingenuity and a modicum of cleverness. Find out what's been tried in conventional alarm systems before you go off computerizing your home security system, though. \$4.95.

____ **Introduction to Biomedical Electronics** by Edward J. Bukstein. What's been done in robot doctors? Nothing so far. But in terms of electronic aids to physicians and practices of health researchers, consult this background review of the field of biomedical electronics. \$5.50.

____ **What to Do After You Hit Return of PCC's First Book of Computer Games.** This is PCC's first book of computer games, a compendium which includes descriptions of numerous games, and listings of 37 selected BASIC games. \$6.95.

Send to:

BITS, Inc
70 Main St
Peterborough NH 03458

Name _____

Address _____

City _____ State _____ Zip _____

Signature _____



Check payment method:

My check is enclosed

Bill my MC No. _____ Exp. date _____

Bill my BAC No. _____ Exp. date _____

Total for all books checked \$ _____

Postage, 25 cents per book for _____ books \$ _____

Grand Total \$ _____

You may photocopy this page if you wish to leave your BYTE intact. Please allow six weeks for delivery.

A BIT More

When you build a project, you need information. All you find in the advertisements for parts are mysterious numbers identifying the little beasts . . . hardly the sort of information which can be used to design a custom logic circuit. You can find out about many of the numbers by using the information found in these books. No laboratory bench is complete without an accompanying library shelf filled with references.

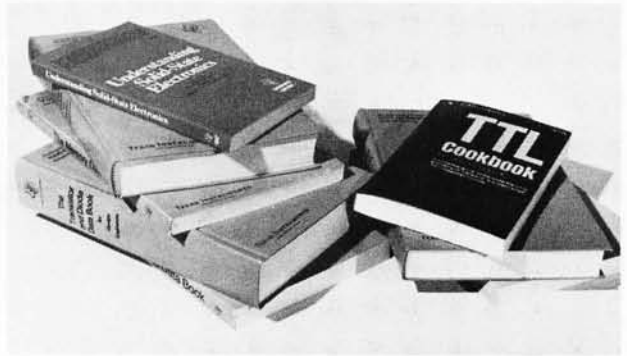

Order these absolutely essential references from Texas Instruments today:

- The TTL Data Book for Design Engineers, \$3.95.
- The Supplement to the TTL Data Book for Design Engineers, \$1.95.
- The Linear and Interface Circuits Data Book for Design Engineers, \$3.95.
- The Semiconductor Memory Data Book for Design Engineers, \$2.95.
- The Transistor and Diode Data Book for Design Engineers, \$4.95.
- The Power Semiconductor Handbook for Design Engineers, \$3.95.
- Understanding Solid State Electronics, \$2.95.
- The Optoelectronics Data Book for Design Engineers, \$2.95.
- Designing with TTL Integrated Circuits, edited by Robert L Morris and John R Miller, published by McGraw-Hill, \$24.



The **TTL Cookbook** by Don Lancaster, published by Howard W Sams, Indianapolis. Start your quest for data here with Don's tutorial explanations of what makes a TTL logic design tick. 335 pages, \$8.95.

Microcomputer Design by Donald P Martin. Edited and published by Kerry S Berland, Martin Research. Purchase your copy of the definitive source for circuitry and hardware design information on the 8008 and 8080 computers today. Even Intel, the originator of the microprocessor revolution, is hard put to compete with the wealth of information found in Martin Research's new second edition of **Microcomputer Design**. This is the book which was originally published as an expensive (but quite practical) engineering report in loose leaf form, at about the time the microprocessor technology was first catching on in the form of the 8008. This 388 page second edition of the manual is loaded with detailed information on how to build and use computers based on the 8008 and 8080. \$25.

Send to:

BITS, Inc
70 Main St
Peterborough NH 03458



Check payment method:

- My check is enclosed
- Bill my MC No. _____ Exp. date _____
- Bill my BAC No. _____ Exp. date _____

Name _____

Address _____

City _____ State _____ Zip _____

Signature _____

Total for all books checked \$ _____
Postage, 25 cents per book for _____ books \$ _____
Grand Total \$ _____

Please allow six weeks for delivery.

You may photocopy this page if you wish to leave your BYTE intact.

A Universal Turing Machine

Jonathan K Millen PhD
661 Main St
Concord MA 01742

Everyone who has had an elementary course in the mathematical foundations of computer science knows you don't actually *build* Turing machines, you just theorize about them. Besides, what about that infinite tape? Well, the temptation was too great to resist. After all, you can do anything with a Turing machine that you can with any other kind of computer. It just takes longer. As for the tape, only a finite amount could ever be used in your lifetime anyway.

Strictly speaking, a Turing machine is merely a program in a certain simple language. A *universal* Turing machine, or UTM, is one that expects two inputs: a Turing machine program, and some data for that Turing machine. The UTM then runs the input machine interpretively. A few medium scale integration chips can do that job, and this article will show how.

The language in which Turing machines are written is the machine language for a correspondingly simple architecture. Like most computers, it has a main memory. This memory is called a *tape* because it can be accessed only sequentially. That is, if memory location n is being read now, only $n-1$ or $n+1$ can be read in the next instruction. Never mind the name "tape"; as far as we are concerned, the machine has an ordinary semiconductor memory, addressed with an index register that can only be incremented or decremented by one in each instruction. The index register will be called the *head* to appease the Turing machine purists.

Each word, or addressable tape location, contains one "symbol." A Turing machine can use any finite set of symbols, but it is known that a set of two is sufficient to perform any computation: 0 and 1. A two

symbol UTM is discussed here because it is the easiest to implement, even though a 256 symbol (eight bits per symbol) machine is better suited for most applications. Look at it this way: the memory is bit addressable. (An incidental benefit is that there are no worries about parallel to serial conversion for serial IO devices with a serial UTM!)

There is only one instruction in the language; it combines the functions of load, store, increment or decrement index register, and conditional branch. Its format is:

w,d,a

where w , d , and a are all operands, since you don't need an operation code when you have only one instruction. The first operand, w , is a bit value to be written into the tape location currently addressed by the head. The second operand, d , tells whether to advance the head left (L) or right (R). The Turing machine's memory goes from left to right in the direction of increasing addresses. The last operand, a , is a branch address.

The branch address, a , points to a *pair* of instructions: One is executed if the current tape location contains a 0, the other if it is 1. The UTM is said to "read" the tape when it determines which instruction of the pair to execute. A pair of instructions is called a "state." A one state program to clear the tape is shown in figure 1.

It is undoubtedly hard to believe, with only this much exposure to the Turing machine language, that it can be used to emulate any instruction set. The belief that Turing machines are adequate to perform any numerical or symbolic algorithm is known as Church's Thesis, after the logician Alonzo Church. Church's Thesis cannot be proved mathematically because it cannot be stated rigorously, but it has stood the test of time. No one has been able to express a computational algorithm that no Turing machine can perform, and most educated people long ago gave up trying. Other

STATE	BIT READ	
	0	1
1	0,R,1	0,R,1

Figure 1: A one state Turing machine program to clear the tape has two instructions. Whether a 0 or 1 is read, the corresponding instruction writes 0, advances the head location one step right, and loops to the same state.

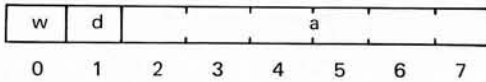

Figure 2: This 8 bit instruction format addresses 64 states directly. The w bit is written on the tape. The d field has 0 for R, 1 for L. Bit 7 is the low order bit of the next state address, a.

instruction sets and machine architectures can be more efficient, of course.

To implement a UTM, we have to decide on a storage format for the instructions. The 8 bit format in figure 2 is suggested to start with. Separate memories are used in this UTM design for the input Turing machine program and its data. If each instruction takes one byte in the program memory, there is just room in a single 2102 for 64 states. Six bits are used in the instruction for the state address a [This field can be used to hold a displacement from the current address in designs with more program memory.], leaving one each for w and d. To encode d, we will use 0 for R and 1 for L. One address line selects the proper instruction from the pair of instructions in each state. Thus, the state memory address has three parts: a 6 bit state address, an instruction selector bit, and three bits for the bit position.

The three parts of the state memory address are kept in three registers: a program counter PC with a parallel load input for the state address; a single flip flop R for the instruction select bit, and the low order three bits of a 4 bit counter S for the instruction bit address. Figure 3 shows the part of the circuit that handles normal instruction execution. Two of the boxes in figure 3 represent more than one IC. The program counter is a cascade of two 74161 counters clocked in parallel, the carry output of the first connected to the T enable input of the second. The head is a cascade of three 74191 bidirectional counters clocked in parallel. The ripple outputs of the lower two are connected to the enable inputs of the next higher ones.

To execute the currently addressed instruction, the bit counter S goes through its cycle of 16 once, shifting the instruction twice through an 8 bit parallel output shift

Figure 3: The Universal Turing Machine (UTM) has a tape and a program memory, each with its own address register. As the instruction is shifted out of the state memory, its operands are clocked into the right places by the counter and decoder logic. The R and D registers are needed for timing reasons. Additional circuitry will be needed for control and loading. (See figure 6.) For visual clarity, outputs of the DECODER 74154 are shown directed to numbered terminals corresponding to clocking inputs of the various other blocks of the design. Lines with an "X" mark points of change when adding control logic of figure 6.

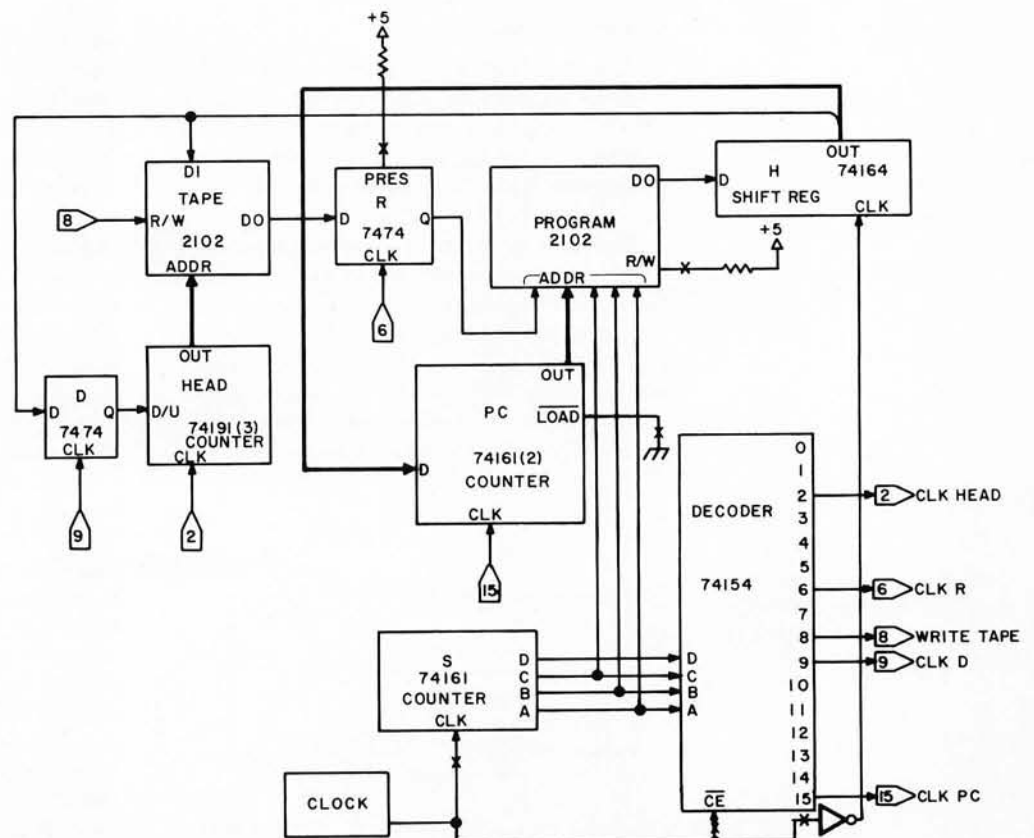

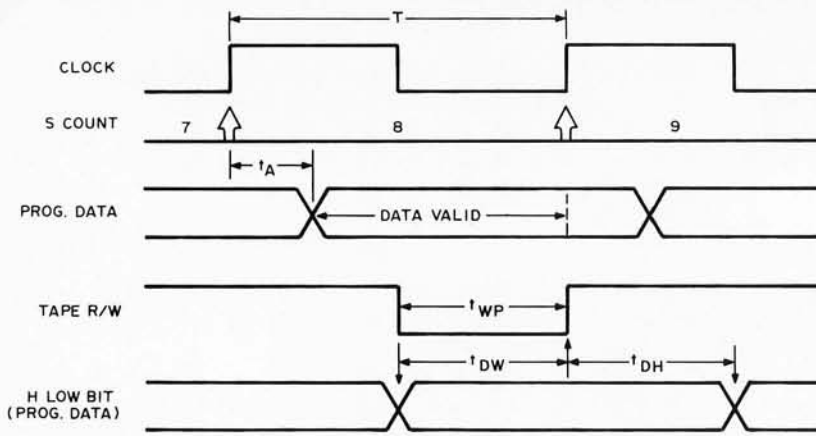

Figure 4: The w bit of an instruction is read from the program 2102 and written into the tape 2102 with the sequence of events shown in this timing diagram. The w data is shifted into H so that it will be steady during the data setup (t_{DW}) and data hold (t_{DH}) intervals. The clock half cycle must be longer than t_A , which is $1 \mu s$ for a slow 2102.

register H. At appropriate points in the cycle, the tape data out bit is copied into R, the w bit is caught and written onto the tape, the d bit is caught and copied into a flip flop, D, and the head is pulsed. At the end of the cycle, the program counter is loaded from H with the next state address. This is all quite similar in spirit to what goes on in any central processing unit.

Sequencing Details

The flip flop R is needed to retain the original instruction address after the tape data is changed in step 8. The flip flop D is needed to keep the direction control steady during the entire low portion of the clock pulse to the 74191 counter.

The counter S and its associated decoder form the "sequence controller" for the UTM, distributing pulses to the clock inputs and other control inputs of the other integrated circuits. The 74154 decoder outputs are normally high. A low level pulse at its enable input is transmitted to whichever output line is currently addressed by the

counter S. The flip flops and counters all change state on the 0 to 1 transition of the clock; that is, on the trailing edge of the inverted clock pulse.

There is some choice in assigning step numbers to the CLK HEAD and CLK R functions. CLK HEAD can be done any time after step 9, CLK D, but before the next CLK R. CLK R can be done any time after step 15, CLK PC, but before step 8, so that the right instruction will be used.

The shift register H is always going. Its contents are ignored during the first eight pulses of the cycle, but the instruction bits are caught and used on the second time through. The clock is inverted before it goes to the shift register so that the shift register will change state on the falling edge of the clock, and be stable on the rising edge, when its contents are being read out to D, PC, and the tape.

Why is the tape data input taken from the low order shift register output rather than directly from the state memory data output? The timing diagram in figure 4 has the answer, and it also shows how the maximum clock frequency can be determined from the 2102 specifications.

Timing

The clock pulse is shown as a square wave in figure 4, but its high and low portions can be of any length greater than their respective minima. The counter S, which has the instruction bit address, changes with the rising edge of the clock, as marked. (Gate delays are not indicated in this diagram because they are much smaller than the 2102 delays.) The state memory data output changes within a time t_A , the 2102 access time, after the bit address changes. The data is guaranteed valid from after the access time to the next address change. At the falling edge of the clock, the state data is clocked into the shift register H. Note that the high level portion of the clock must be longer than t_A in order to guarantee that valid data will be shifted into H. The low order bit of H remains steady until the next falling edge of the clock. During step 8, the low level of the clock is sent to the R/W input of the tape 2102. Thus the write pulse time, t_{WP} , is equal to the low level portion of the clock. The state input is taken from the low order bit of H. The data setup time t_{DW} starts when the data is shifted in and goes until the end of the write pulse. This is also equal to the low level portion of the clock. The input data remains steady during the next high level portion of the clock, and this period is the data hold time t_{DH} . Note that if the tape data input were taken from the state

Figure 5: An astable multivibrator is used for the clock. Its half-cycle time is given by the formula $\Delta T/2 = 0.693 RC$

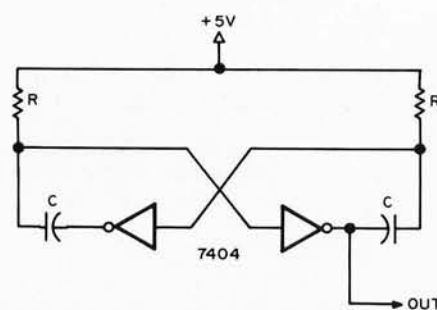
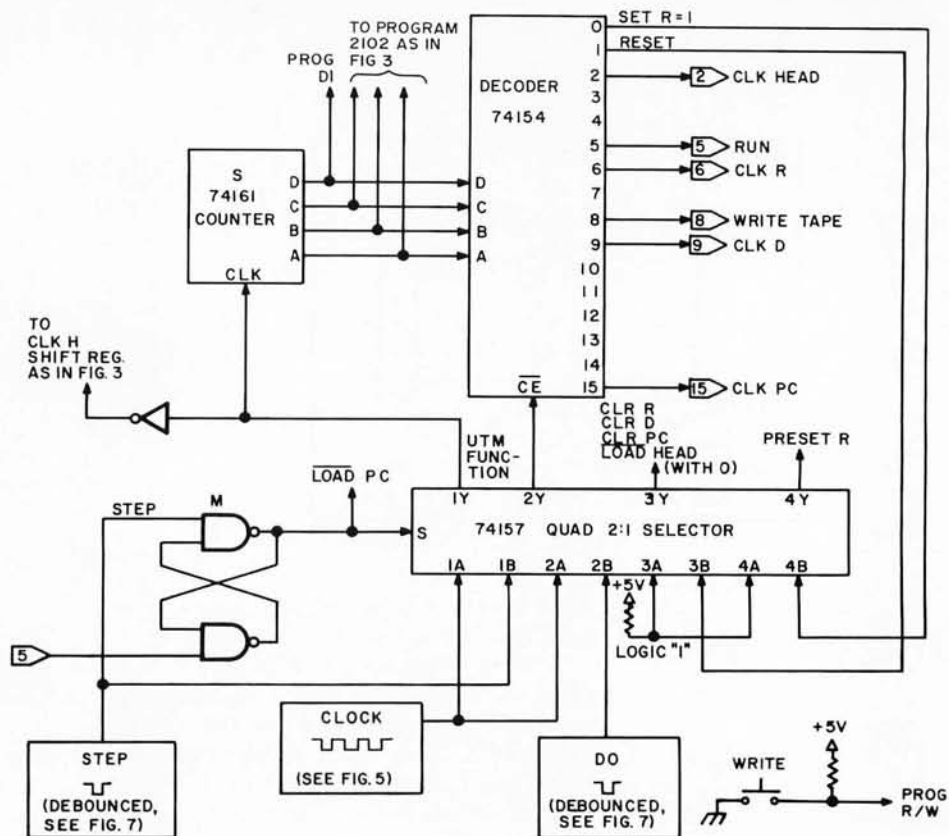

Figure 6: This figure shows the additional control logic to be added to the basic UTM in figure 3. The counter *S* and DECODER of figure 3 are repeated in this diagram to show the new connections to them. The 74157 acts like a 4PDT relay controlled by the mode flip flop *M*. In run mode, it reproduces the configuration of figure 3. In step mode, the DO button executes the UTM function selected by the STEP button, including the RESET and SET R = 1 functions, which are enabled only in step mode. A WRITE button and a connection from the *S* high order bit to the program data input have been added for program loading. Logical 1 can be a 1k resistor to +5.



data output, the data hold time would be zero, and the write operation might not "take."

We conclude from the above analysis that the high level portion of the clock must be greater than both the maximum t_{A} , which is 1000 ns for a slow 2102, and the minimum t_{DH} , which need only be 100 ns. The low level portion of the clock must be greater than the minimum values for t_{WP} , 750 ns, and t_{DW} , 800 ns. Thus the high level must be at least 1000 ns and the low level at least 800 ns, giving a maximum clock frequency of roughly 500 kHz.

The clock is the astable multivibrator shown in figure 5, with $0.693RC < 10^{-6}$ to satisfy the timing constraints. In fact, if you depend on the values marked on the resistor and capacitor, it might be better to choose $RC < 10^{-6}$ to leave room for tolerances.

Control and Loading

Some additional logic, such as that shown in figure 6, is needed to load programs and data into the memories and get a program started. A mode flip flop *M* constructed from two NAND gates switches the pulse input from the clock to a pair of debounced buttons: a STEP button to pulse the counter *S*, and a DO button to send a pulse to the place selected by the count. The STEP

button sets *M* to "step mode" whenever it is pressed. Note that, in step mode, the STEP button increments the counter by only one; it does not go through a whole instruction. Also, in step mode, nothing happens until the DO button is pressed, except incrementing the count and shifting the instruction through *H*. A pulse to the reset input of the mode flip flop is added as step 5 of the instruction cycle, so you can get back into "run mode" by counting with the STEP button to 5 and then pressing the DO button.

A debouncing circuit for the STEP and DO buttons is shown in figure 7. The normally high output of each button must be used, since a low level from STEP sets *M*,

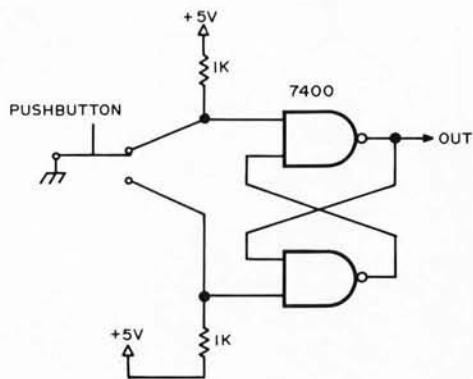

Figure 7: Debouncing circuit for an SPDT push button.

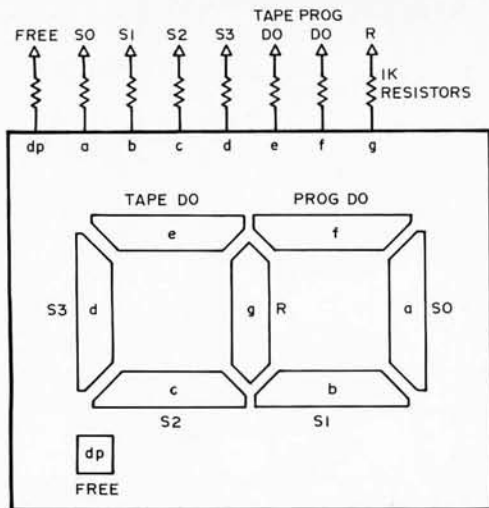

Figure 8: A 7 segment display is a compact way to provide all essential information for control and readout purposes. S_0 – S_3 are the four bits of the counter S . The decimal point is available for other use, such as a logic probe function.

and a low level from DO can cause a write tape operation or reset M to run mode.

A RESET function, enabled only in step mode, zeros the tape and state addresses, and clears R and D , leaving D in the “up” or R direction. After using RESET, selective use of the CLK HEAD and CLK PC functions allows you to count up to any tape and state addresses.

The UTM control panel should display at least the following: all four bits of the count S , the current tape bit, the current instruction bit, and R . I found it convenient to get a 7 segment display and use each segment for one of the bits, as shown in figure 8. The decimal point was connected to a free wire used as a probe for debugging.

Figure 9: Flowchart of a program to write six 1s on a cleared tape. State numbers are in the decision boxes. Process boxes contain w,d . The leftmost 1 produced by the program will be at location 0 if the head is initially at 4. This is the best 4 state “busy beaver” program.

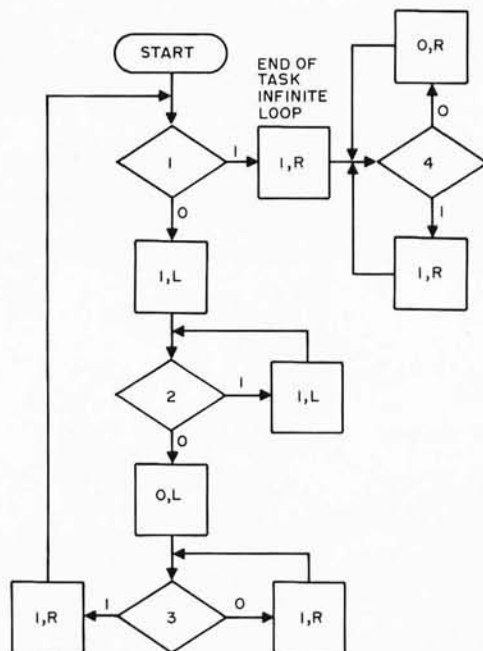

The SET $R = 1$ function, enabled only in step mode, plus a WRITE button, are used in program loading. The state memory data is taken from the high order bit of the counter S . Thus, while you step from 0 to 7, you have an opportunity to write 0 into the current instruction bit, and from 8 to 15 you can write 1. At step 15, hit the DO button to count up to the next state. The program counter is incremented by 1 in step mode, rather than loaded. After you have loaded all instructions with $R = 0$, you RESET, SET $R = 1$, and load the $R = 1$ instructions for all states.

This is an awkward procedure, but it works, and uses the minimum amount of control hardware. For convenience, my own UTM has an input mode and additional enabling logic that permits program loading with just two controls – the STEP button for counting bit – serially through the whole program, plus a DATA button that selects the value written when the STEP button is pressed. This input method facilitates program loading from a cassette.

The CLK HEAD and WRITE TAPE functions are sufficient to load the tape memory with data. After clearing the tape with the program in figure 1, set the PC to a state with $w = 1$ in both instructions. Now, advance the head to each tape location in which a 1 is desired, and “DO” the WRITE TAPE function, with the STEP button down.

Data loading could be facilitated with an instruction cycle mode, in which the count goes from step 5 all the way around once to step 4 each time the DO button is pressed. All it takes is a pulse to set step mode from step 3, plus some logic to enable the pulse when a “cycle” switch is set. A full cycle to step 5 requires more logic to shorten the DO pulse to less than the full cycle.

Figure 10: Listing in UTM notation of the busy beaver program flowcharted in figure 9.

STATE	BIT READ		COMMENTS
	0	1	
1	1,L,2	1,R,4	initial state
2	0,L,3	1,L,2	
3	1,R,3	1,R,1	
4	0,R,4	1,R,4	final scan state (infinite loop)

There is really no data output from this machine, in the usual sense. If you want to see what is on the tape, enter step mode, RESET, and watch the current tape bit display while executing the CLK HEAD function. Something like normal data output can be arranged by adding logic to test for a particular address in the head, such as 0 or all 1s, together with a pulse on the WRITE TAPE line. The bit being written can be sent to an output device.

Once the baseline minimum UTM is assembled, you may be willing to put up with the operating inconvenience temporarily while you experiment with the Turing machine language and get a feeling for its idiosyncracies.

Busy Beaver Programs

“Busy beaver” programs are fun to start with, because they begin with a cleared tape. The object of a busy beaver program is to write as many 1s as possible. Of course, you can make $w = 1$ in both instructions of the clear-tape program in figure 1, and this gives you a program that will set the whole tape to 1s. But, suppose you want a string of exactly 281 1s, for example. How many states would be needed in a program to produce it? An 8 state program will do. More states may be needed for smaller numbers, though. A workable but not necessarily optimal strategy for producing particular length strings of 1s is to combine an n state program that writes a desired n bit binary number with another program that converts an n bit binary number to a string of that number of 1s.

A related problem is to find the greatest exact number of 1s that can be written with a program having a given number of states. It is known that a 3 state program can write at most four 1s, and a 4 state program can write at most six. A 4 state program that writes six 1s is flowcharted in figure 9, and listed in figure 10. The best busy beaver programs are not known for five or more states, however. There is a 5 state program that produces ten 1s, probably the best possible; a 6 state one for 14 1s; and a 7 state one for 29.

Unary Arithmetic

Demonstrations that Turing machines can do arithmetic are often made using the unary system for representing nonnegative integers. The number n in unary is a string of $n + 1$ 1s delimited by 0s. Thus, unary 1 represents the number 0. If the UTM tape has two unary numbers separated by a single 0, adding them is easy: change the separating 0 to 1 and take two 1s off the end. Other arithmetic operations take more ingenuity, but they are all possible.

Multiple Bit Words

The main problem with binary information on the UTM tape is figuring out where it starts and stops. The simplest solution is to group bits into pairs (starting with location 0), so that each pair can represent one of four characters. The characters 00 and 11 can represent the binary digits 0 and 1, and the other two, 01 and 10, can be A and B. A binary number of any length can be stored as a string of 0 and 1 characters beginning after an A and ending at a B. For textual data, you may prefer characters of six to eight bits; it's up to you.

Summary

The universal Turing machine design in the article was aimed at low cost. Constructed from only 15 integrated circuits, it is a complete general purpose stored program computer. Its low cost was made possible by the fact that only one simple instruction had to be implemented. The single Turing machine instruction is general enough, in principle, to program any computation with; although very long and inefficient programs would be necessary for most useful applications. Extensions to the tape and state memories, as well as interfaces for IO, will prove desirable as additions to this design; but the principles of operation are so simple that such additions should be easy. If you are challenged by the programming task, tolerant of long computations, and enjoy tinkering with parts and pieces, a UTM project offers a tremendous potential for enjoyment. ■

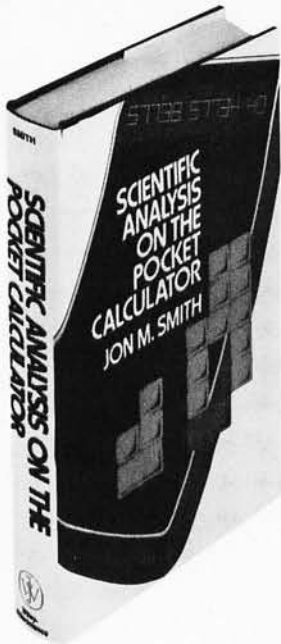

BOOK REVIEWS

Scientific Analysis on the Pocket Calculator
by Jon M Smith, John Wiley & Sons, New
York, 1975, 392 pages and one errata sheet.
\$13.75.

Despite the art on its dust cover, this is not another in the profusion of books on how to play games on and with pocket calculators. (Turn it upside down and read the red print.) This claims to be the first and only book of its kind, and is quite serious, except for just over one page in its appendix.

If you've ever used a large computer, you know that as expensive as they are, one of the largest costs is programming, whether you do it or buy someone else's. Sophisticated programs are for sale in high level languages for all sorts of scientific and business applications. If you want to do some serious but fancy things on a microcomputer (probably not yet fully expanded to 65 K of working memory and with only an abbreviated version of BASIC), you may wonder where you are. Or you may be trying to choose between a high priced calculator and a low priced microcomputer.

This book doesn't seem to have been written to help you as a microcomputer person. But would you believe that you can do many advanced scientific applications on a calculator, whether or not it's programmable, whether or not it has scientific notation, trigonometric functions, parentheses and even whether or not it has any memory? (Of course, the more features the calculator has, the more advanced are the things it can do and the greater the ease of doing them.) How? All you have to do is put the numbers and operators (signs) in the right order, and you can do anything that doesn't involve bigger or smaller numbers than the calculator can display. Jon Smith has rewritten many useful formulas and

equations for you, but to levels of complexity suitable to various calculators. All you need is patience and the skill to catch your mistakes. The author places "emphasis more on understanding the method and providing accuracy consistent with the display in the pocket calculator, on a one-time basis." He freely admits leaning heavily on Richard Hamming's *Numerical Methods for Scientists and Engineers* (McGraw-Hill, 1973). He estimates that in use, pocket calculators are about four times as fast as the old mechanical calculators.

Can this help you with your microcomputer and BASIC? If you have a calculator chip and its interface working, unquestionably. If not, this simplification of procedure should help you to write BASIC statements, subroutines and programs more easily. You'll be able to put "equations" on a single line more often, with more use of nested parentheses and fewer loops. And you'll probably need less memory for the program. However, "the methods chosen here *are not* necessarily the same as those commonly used on large digital computers."

Are you wondering how all this is possible? What's the catch? There's no catch. As you may have suspected, there had to be a better way. This is it. Still, this book is not for everyone. It starts somewhere beyond where the usual "how to use your calculator in the kitchen and home workshop" books leave off. It is intended to help engineers and scientists with a good mathematical background do fairly sophisticated analysis without a computer. Formulas are often given in nested parenthetical form (looking like onions) for approximating roots, trigonometric functions and much more. These are worked out by calculator from the inside out. This is practical up to 10 levels of parentheses, up to six more than the ordi-



TOUCH TONE GENERATOR BY MOSTEK. MK5086N produces the dual-tone multi-frequency telephone dialing signals as used in TT phones and auto patches. Uses inexpensive crystal, 1 resistor and 1 capacitor. Both tones are internally mixed and buffered to a single output - simple! Two additional output switches can control timers, transmitter, mute receiver, enable audio amp, etc. Uses our Chomerics keyboard. Comes in 16 pin plastic DIP. MK5086N.....\$8.95...Crystal for MK5086N.....\$1.90 Specs for MK5086N 80c. Kit of parts including etched and drilled P.C. board and one of our Chomerics keyboards.....\$19.95

MC14412 UNIVERSAL MODEM CHIP

MC14412 contains a complete FSK modulator and de-modulator compatible with foreign and USA communications. (0-600 BPS)

FEATURES:

- .On chip crystal oscillator
- .Echo suppressor disable tone generator
- .Originate and answer modes
- .Simplex, half-duplex, and full duplex operation
- .On chip sine wave
- .Modem self test mode
- .Selectable data rates: 0-200
0-300
0-600

- .Single supply
VDD=4.75 to 15VDC - FL suffix
VDD=4.75 to 6 VDC - VL suffix

TYPICAL APPLICATIONS:

- .Stand alone - low speed modems
- .Built - in low speed modems
- .Remote terminals, acoustic couplers

MC14412FL.....	\$28.99
MC14412VL.....	\$21.74
6 pages of data.....	.60

Crystal for the above.....\$4.95

MC14411 BIT RATE GENERATOR.

Single chip for generating selectable frequencies for equipment in data communications such as TTY, printers, CRT's or microprocessors. Generates 14 different standard bit rates which are multiplied under external control to 1X, 8X, 16X or 64X initial value. Operates from single +5 volt supply. MC14411.....\$11.98 4 pages of data......40 Crystal for the above.....\$4.95

REMOTE CONTROL TRANSMITTER. MC14422P is a 22 channel ultra-sonic remote control transmitter I.C. CMOS uses little power and only a few external passive components. Applications include TV receivers, security controls, toys, industrial controls and locks. 16 pin DIP plastic pkg. MC14422P..... with specs.....\$11.10

PRECISION REFERENCE AMP LH0070-1H provides a precise 10.0 volts for use in BCD A to D converters or meter calibrators. Typical initial accuracy is .3% ($\pm .03V$). Comes in TO-5 can. LH0070-1H.....with specs.....\$5.35

4 DIGIT COUNTER. MM74C926 is a 4 digit counter with 7 segment output. Carry output for cascading and internal display select allows outputting of counter or set of internal latches. 3 to 6V operation. Great for clocks, event and frequency counters. MM74C926 - with spec sheet.....\$12.00

3 DECADE (BCD) COUNTER CHIP MC14553BCP consists of 3 negative edge triggered synchronous counters, 3 quad latches and self scan multiplexed, TTL compatible outputs. MC14553BCP.....\$8.72 Spec sheets.....\$6.60

TELETYPE CODE CONVERSION CHIP MM5220BL converts 5 level Baudot into 8 level ASCII. Use this chip to make your old TTY talk to your new computer. MM5220BL.....\$18.00 Specs for the above......30

MOS TIME BASE KIT. Only 1" X 1.5". Input 5 to 15 VDC, output is 60Hz square wave for portable or mobile clocks. PC board is drilled! MTBK-60HZ.....\$5.88



AMP LANNY

Says

If your project schedules are slipping and you're taking lumps with high prices and poor service, let the guys at Tri-Tek put it on ice for you--- (and Happy Holidays)

RCA

GOLD CHIP Linear Integrated Circuits

Brand new process by RCA in which the aluminum metalization has been replaced by gold. The chip is then hermetically sealed. What this means to you is unprecedented reliability and uniformity. Plastic parts that meet mil specs!! Tri-Tek is proud to be the first to bring this new level of performance to you at SURPLUS PRICES. Why buy regrades??

CA301A..Improved, general purpose op-amp, 8 pin dip..	.59c
CA307...Super 741 op-amp, 8 pin dip.....	.52c
CA324...Compensated quad op-amp, 14 pin dip.....	\$1.80
CA339A.. Low offset quad comparator, 14 pin dip...	\$1.59
CA741C..Famous general purpose op-amp, 8 pin dip...	45c
CA747C..General purpose dual op-amp, 14 pin dip...	82c
CA748C..Externally compensated 741, 8 pin dip.....	49c
CA1458..General purpose dual op-amp, 8 pin dip.....	69c
CA3401..Quad single supply (5-18V) op amp, 14 pin..	89c

Another super buy from RCA. CA555 timer. 8 pin dip. 59c

CLASS B AUDIO DRIVERS

MC3320P and MC3321P are pre amps and drivers for class B complementary output transistors. Self balancing allows for no special HFE matching of output transistors. MC3320P operates up to 30V, 89db gain.....\$2.25 MC3321P operates up to 14V, 32db gain.....\$1.98 Specs for both......40c

POWER FET

VMP1 is an N channel MOS FET capable of switching 1 Amp in 5nSeconds. Can be used as RF power Amplifier with power gain of 40 db! VMP1.....TO-3.....\$9.75 Specs......60c

RCA 40673 dual gate MOS FET.....	\$1.01
2N 5485 N channel J FET.....	.69c
2N 5486 N channel J FET.....	.69c

DATA BOOKS BY NATIONAL SEMICONDUCTOR DIGITAL. Covers TTL, DTL, Tri-State, etc. \$3.95 **LINEAR.** Covers amplifiers, pre-amps, op-amps, .. \$3.95 **LINEAR APPLICATIONS.** Dozens of application notes and technical briefs covering the use of op-amps, regulators, phase locked loops and audio amps..... Vol 1 \$3.25 **CMOS.** Gates, Flip Flops, registers, functional blocks \$3 **VOLTAGE REGULATORS.** A must for anyone making a power supply. Complete theory including transformers, filters, heat sinks, regulators, etc..... \$3.00 **MEMORY.** Information on MOS and Bipolar memories: RAMS, ROMS, PROMS and decoders/encoders... \$3.95 **INTERFACE.** Covers peripheral drivers, level translators, line driver/receivers, memory and clock drivers, sense amps display driver and opto-couplers..... \$3.95 (Outside U.S., add postage for 1.5lbs)

SPECIAL FUNCTIONS DATA BOOK contains detailed information for specifying and applying special amplifiers, buffers, clock drivers, analog switches and D/A-A/D converter products.....\$3.25 **AUDIO HANDBOOK** contains detailed discussions, including complete design particulars, covering many areas of audio with real world design examples...\$3.25

5 DECADE COUNTER

MC14534BCP is a 5 decade real time counter with multiplexed BCD outputs. Can be cascaded for longer counts. Typically 5MHz operation at 15 Volts. CMOS structure for low power consumption. MC14534BCP.....\$11.25

10 AMP VOLTAGE REGULATOR

MPC1000 is a 10 Amp positive voltage regulator adjustable from 2 to 35 VDC. 0.1% line and load regulation with 0.005% per °C temperature stability. Can be fold-back limited. Here is high current, high power with minimum bother. MPC-1000.....\$16.85 Specs for above......60c

NEW NATIONAL BOOK---LINEAR APPLICATIONS VOL II

Takes up where Vol I left you---All the latest linear devices. Along with Vol I you have a great source of application data on the most widely used devices as well as new types just appearing.....\$3.25

INTRODUCTION TO MICRO COMPUTERS

New book from OSBORNE. The first edition of this classic was a huge success. Now, due to the growth of information on the subject Osborne has expanded the work into 2 volumes. Vol I covers basic concepts, Vol II discusses real world micro computers. IMC-002 Vol I.....\$8.00 IMC-002 Vol II.....\$8.00

***NOTHER NEW BOOK FROM OSBORNE.**

"8080 PROGRAMMING FOR LOGIC DESIGN" explains how an assembly language program within a microcomputer system can replace combinatorial logic ---- for logic designers, programmers or anyone who is interested in real and powerful applications of the ubiquitous 8080. PLD-4001.....\$8.00



TRI-tek, inc.

6522 NORTH 43RD AVENUE,
GLENDALE, ARIZONA 85301
phone 602 - 931-6949

We pay shipping on all orders over \$10 US, \$15 foreign in US funds. Orders under \$10, please add \$1 handling. Please add insurance. Master Charge and Bank America cards welcome, (\$20 minimum) Telephone orders may be placed 11AM to 5PM daily, Mon thru Fri. Call 602-931-4528. Check reader service card or send stamp for our latest flyers packed with new and surplus electronic components.

nary form of equations, because the number of key strokes increases proportional to the number of terms in nested form, rather than proportional to the square of the number of terms.

Much use is made of power series, generated by using Taylor's theorem, Maclaurin's theorem, Chebyshev polynomials, etc. There is an interesting discussion of roundoff error (including a table with an error in computation, no doubt the usual academic inside joke) emphasizing the avoidance of subtraction of nearly equal numbers.

After the first chapter, the book gets into fairly heavy math. Chapter 2 covers difference tables, interpolation and extrapolation. Chapter 3 covers progressions, infinite and binomial series, transformation of series, quadratic and cubic equations, successive approximation, elementary transcendental functions, plane and spherical triangles and complex variables and functions. Chapter 4 goes on to numerical evaluation of exponential, sine and cosine integrals, the gamma and error functions, Fresnel

integrals, Legendre's, Chebyshev, Hermite and Laguerre polynomials, hypergeometric functions and Bessel functions. The next three chapters take on Fourier analysis, numerical integration, and linear systems simulation (using difference equations and variance propagation). Chapter 8 gives Chebyshev and rational polynomial approximations for analytic substitution. Chapter 9 deals with determining the roots of a function. Chapter 10, on statistics and probability, is far simpler than the preceding chapters, but here a calculator with memory is needed. The last two chapters, about 75 pages, deal with the special capabilities of programmable pocket calculators, first in general and then for use in optimization. Four appendices cover tricks, matrix analysis, complex numbers and functions, and selected reprints from Hewlett-Packard's HP-35 MATH PAC for complex variable analysis and hyperbolic and inverse hyperbolic functions.

John F Sprague
Allendale NJ

A Guided Tour of Computer Programming in BASIC by *Thomas A Dwyer and Michael S Kaufman*, Houghton Mifflin Company, Boston, 1973; 8¼ X 11, 156 pages. Paperback \$3.60.

Although this book was written to teach BASIC programming to secondary school students, it is also an excellent book for adults as well as young people. Since very little knowledge of mathematics beyond basic arithmetic is needed to understand the authors' many example programs, this is one of the few BASIC programming texts that can be used comfortably by people who

know little mathematics beyond that taught through sixth grade.

The book is organized into four parts — "Getting Ready for the Journey" and "The Economy Tour," which are sufficient for many programming applications; and "Techniques for the Seasoned Traveler" and "Far Away Places," which contain more advanced programming techniques and applications. "Getting Ready for the Journey" features a comparison of minicomputers and time sharing computers and shows how to communicate with each system. The procedures described are similar to what will be found in many microcomputer based systems. This section also has a model of what a normal session at a terminal might look like. The example session, which uses only the key words LET, PRINT, and END, has margin notes pointing to the mistakes and telling how to correct them. "The Economy Tour" shows how to use the key words PRINT, END, LET, INPUT, GOTO, IF ... THEN, STOP, FOR ... NEXT, and STEP to make BASIC statements and illustrates how to sequence statements into useful programs. This section concludes with one of the best explanations I have seen on how to use paper tapes. "Techniques for the Seasoned Traveler" explains and illustrates the key words DIM, REM, TAB, READ ... DATA, RESTORE, GOTO ... OF ..., ON ... GOTO ..., and GOSUB ... RETURN as well as the functions SQR, INT, ABS, and

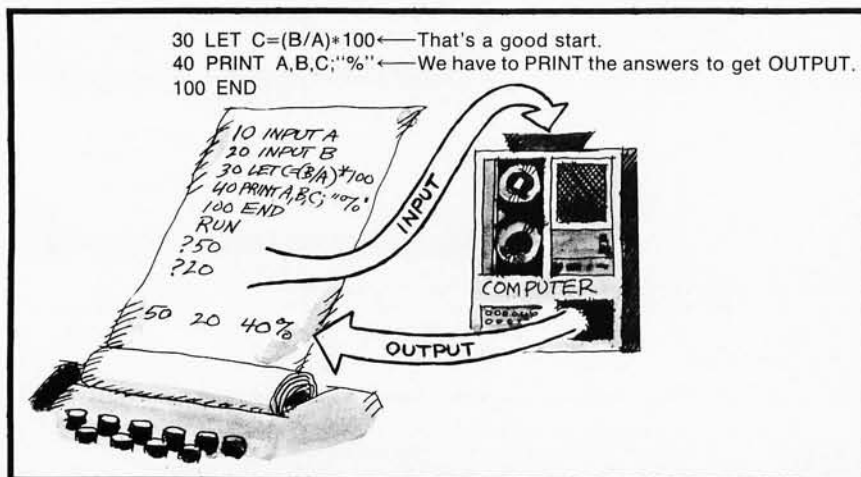

HAPPY HOLIDAY FOLKS!

THANK YOU SO MUCH

ECONORAM™

in kit form
\$99.95

We took everything we learned from selling 4Kx8 RAM boards for the past year, added some of this year's circuit tricks, and came up with ECONORAM---a memory board that is even more remarkable due to its low price. We've engineered this with the user in mind, giving you several benefits:

- * 3 regulators to share power load, plus optimized thermal design, means a cooler running microcomputer
- * Typical current consumption of under 750 ma gives your power supply a break
- * Fast--- Zero wait states
- * All TTL support ICs are latest Low Power Schottky types
- * For reliable and unambiguous data transfer, all addresses, data lines, and outputs are buffered for minimum loading and maximum output capability
- * Power-on clear included

All these features are packed on to an Altair-sized, industrial quality double-sided PC board, with sockets for all ICs, 7 tantalum capacitors for power supply decoupling, and plenty of bypass capacitors---39 of them, in fact, as well as a logic print and instructions.

also available assembled **\$129.95**

Our popular ECONORAM 4Kx8 RAM board is now available assembled, tested, and warranted for one year. Plug it in to your Altair or IMSAI and enjoy the same performance that has made the kit such a success---guaranteed zero wait states and current drain of 750 mA or less; on board regulation, easy address selection, and lots more.

1/2 AMP POWER SUPPLIES

\$7.95 + 2 LBS SHIPPING

REGULATED, SHORT-PROOF, THERMALLY LIMITED. HALF AN AMP CONTINUOUS, OR 1 AMP INTERMITTENT. SAVE YOURSELF THE HEADACHE OF DESIGNING YOUR OWN; LET US COLLECT THE PARTS AND SAVE YOU MONEY TOO. SPECIFY 5, 6, 8, OR 12 VOLTS. LESS CASE AND HARDWARE.

Now you have a choice---specify wire wrap pins (illustrated) or solder-tail with .250" row spacing. For IMSAI and Altair peripherals. Wire wrap part # S-100WW. Solder-tail part # S-100ST.

COME AND GET 'EM...



"EconoRom" \$179.95

ALTAIR 8800/IMSAI PLUG-IN COMPATIBLE. This is a 4K by 8 EROM board...the ideal place for putting software, be it assembler, editor, or any custom set of routines. Additionally, this board may expand to 8Kx8 by simply adding more sockets and EROMs; also available is a 2Kx8 version if you don't need a full 4K. LOW POWER: 8K board requires 1/2A @ 5V, & 150 ma @ -12V. Buffered addresses for lightest loading, buffered outputs for maximum drive. Kit includes sockets, double-sided quality PC board, on board regulators, logic print, and instructions. Program it yourself, or have us do the programming.

8K X 8 BOARD \$269.95

2K X 8 BOARD \$135.00

8080 Software Board \$189.95

We took our ECONOROM board kit, but instead of including blank EROMs, these are programmed with assembler, editor, & monitor routines for the 8080. This is a valuable first step if you're trying to get away from machine language programming. There's not really enough room here to fully describe all the functions of the software...but if you send us \$2.95 (refundable with order), we'll send you our software packet that includes instructions listing, schematic, and assembly data.

74LS TTL

00	\$0.36	30	\$0.36	132	\$1.50	175	\$1.35
01	0.36	32	0.38	138	1.38	221	1.38
02	0.36	37	0.53	139	1.38	240	1.88
04	0.42	38	0.53	155	1.38	257	1.25
08	0.38	42	1.25	157	1.25	258	1.38
10	0.36	74	0.56	160, 161,		273	2.25
11	0.38	75	0.85	162, 163=		283	1.20
20	0.36	109	0.60	\$1.85 ea.		367	1.00
21	0.38	124	2.50	168	1.87	368	1.00
22	0.38	125	0.75	169	1.87	377	1.88
27	0.38	126	0.75	174	1.38	378	1.38

GODBOUT

BILL GODBOUT ELECTRONICS
BOX 2355, OAKLAND AIRPORT, CA 94614



TERMS: Add 50¢ handling to orders under \$10. Cal res add sales tax. No COD orders. Place credit card orders (BankAmericard® and Mastercharge®) by calling 415-562-0636, 24 hours.

8 BIT CHIP SETS

NOTE: These chip sets come with ICs & pinout sheet

8008 CHIP SET

\$29.97

(1) 8008 CPU (8) 2102s (1) 5203 2K EROM

8080A CHIP SET

\$35.60

Includes 1-8080A + 8-2102LIs. All memories in our chip sets are LOW power and guaranteed 450 ns.

16 BIT CHIP SETS

NOTE: Both chip sets include PACE DATA PACKET

PACE CHIP SET

\$95

(1) PACE CPU (4) DS3608 (1) DS0026
(1) DM8837 (2) 5204 ROMs

DELUXE PACE SET

\$175

(1) PACE CPU (4) DS3608 (1) DS0026
(1) DM8837 (32) 2102s (4) 5204 ROMs

FIVE/\$1

Standard phenolic type.
LTD QTY

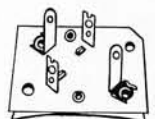

TO3 SOCKETS

PACE PACKET

Learn about this powerful 16 bit CPU for \$2.50. 80 pp.

RND. "Far Away Places" has nine application programs—two dealing with data analysis, two on nonnumeric uses of computers, a simulation, a game, and three business-oriented examples. The system commands RUN, LIST, SCR, BYE, PUNCH, TAPE, and KEY are presented early in the book with a careful explanation of the differences among system commands, key words in BASIC, and BASIC statements.

The authors stress interactive computing throughout the book and also use an interactive, conversational style to communicate their ideas to the reader. The 31 sections in the book contain pencil and paper questions for the reader to answer, exercises where the reader is asked to pretend that he or she is a computer and RUN (on paper) example programs, interesting exploratory programs to be executed on line, and brief reviews of previously presented skills and concepts. The authors know precisely where the programming novice may become confused and offer frequent "morals," "notices," "notes," "practical rules," and "formal rules," all of which are highlighted in red boxes. For example, in the first part of the book the reader is reminded to press RETURN at the end of each program line and to SCRatch an old program before typing a new one. Later the reader is shown what can happen when one tries to INPUT a common fraction as numeric data. Care is taken to introduce precise computer language and to explain it using everyday terminology. Many BASIC statements are explained by telling how they could be said in English.

Good use is made of analogies and examples in explaining how computers operate, how to use key words, and how to write BASIC statements. For instance, IF . . . THEN statements are compared to a bus driver who "loops" through his route 10 times, keeping track of the number of loops with a counter, before returning to the garage. In using this book, the reader is gradually taken from an instructor-dominated learning mode to a dual learning mode and on to a solo mode as he or she reads from page 1 to page 156. For example, the first on-line activity is to enter, list, and run a prepared program; other exercises require the reader to modify and improve given programs; later in the book the reader is asked to write his or her own programs to carry out specified tasks.

This book has a number of distinctive features which facilitate learning BASIC programming:

1. No partial programs which could mislead the reader are given. Every

example of a BASIC key word or a BASIC statement is imbedded in a complete, executable program with sample output.

2. The book is very well organized. Large type is used throughout. Engaging red and black cartoon-like illustrations abound. (See one such reproduced in black and white on page 122.) Callouts boxed in red with arrows pointing to program lines are used to explain BASIC statements. Things are easy to locate by either browsing through the book, using the Contents, or looking through the Index and Summary in the back of the book. Selected answers and hints for the exercises are grouped near the end of the book.
3. Typical idiosyncracies due to the particular computer system being used are pointed out as they are encountered.
4. In each short section the person using the book is required to go to a terminal and become an active participant in interactive computing.
5. Most of the example programs are both interesting and practical.
6. BASIC key words and programming techniques are introduced when they are needed to make the computer carry out desired tasks. The authors also explain why a "bulldozer" technique such as using GOSUB . . . RETURN may be preferable to a "shovel" technique such as using GOTO. Flowcharting is presented not as an end in itself but as a useful tool to organize and explain programs.

This book has few shortcomings. However, an explanation could be given as to why a switch is made early in the book from numbering program lines 1, 2, 3, . . . , n to numbering them 10, 20, 30, . . . , $10n$. Several of the programs that illustrate the use of bulldozer type BASIC key words could be clarified by inserting additional callouts to certain sections within each program.

In summary, this is one of the best of the several score BASIC programming books and manuals on the market, and it is certainly the most interesting of them all. Even after programming in BASIC for many years I still enjoyed reading this interesting book. If you are about to select a book for use in teaching and learning BASIC be sure to consider *Guided Tour*.

Frederick H Bell
Coordinator, Mathematics Education Programs
University of Pittsburgh
Pittsburgh PA 15260■

FAIRCHILD

ANNOUNCES THE

FAIRCHILD

SOLID STATE

TECHNOLOGY KIT

- FOR THE EXPERIMENTER WITH TASTE FOR "STATE OF THE ART" PRODUCTS
- COMPLETE SPECIFICATIONS ARE PRINTED ON THE BACK OF EACH TECHNOLOGY KIT

FTK0020

FTK0020

FTK0106



CARD FRONT

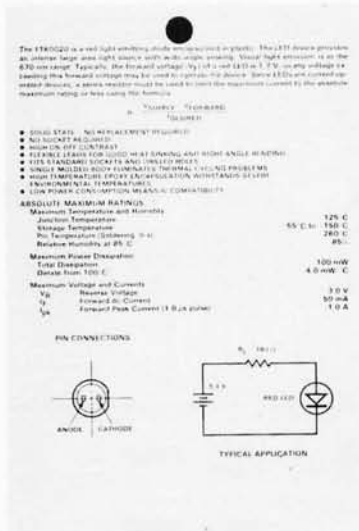

CARD BACK



CARD FRONT

DIGITS

FTK0001	0.5" High Common Cathode Digit	\$1.00
FTK0002	0.5" High Common Anode Digit	1.00
FTK0003	.357" High Common Cathode Digit	.75
FTK0004	0.8" High Common Cathode Digit	2.00
FTK0005	0.8" High Common Anode Digit	2.00

0.8" HIGH DISPLAY ARRAYS

FTK0010	12 Hour, 3½ Digit Clock Display	7.00
FTK0011	24 Hour, 4 Digit Clock Display	8.00

LED LAMPS

FTK0020	10 Red LED Lamps	1.00
FTK0021	5 Mixed Colored LED Lamps	1.00
FTK0022	10 LED Mounting Clips	1.00
FTK0023	5 Three Piece LED Mounting Adapters	1.00

PHOTO TRANSISTORS

FTK0030	5 Flat Lens Photo Transistors	1.00
FTK0031	5 Round Lens Photo Transistors	1.00
FTK0032	3 Flat Lens Photo Darlington	1.00
FTK0033	3 Round Lens Photo Darlington	1.00

PHOTO ARRAYS

FTK0040	9-Element Tape Reader Array	16.00
FTK0041	12-Element Card Reader Array	24.00
FTK0042	Reflective Opto Coupler	4.00

COUPLERS

FTK0050	3 General Purpose Opto Couplers	1.00
FTK0051	Darlington Opto Coupler	1.00

MOS CLOCK CIRCUITS

FTK0400	Digital Clock/Calendar Circuit (FCM7001)	7.00
FTK0401	Digital Clock/Calendar with BCD Outputs (FCM7002)	7.00
FTK0402	Direct Drive Digital Clock Circuit with AC Output (FCM3817A)	5.00
FTK0403	Direct Drive Digital Clock Circuit with DC Output (FCM3817D)	5.00
FTK0405	Direct Drive Digital Clock/Calendar Circuit (FCM7015)	6.00

KITS

FTK0106	Automobile Clock Kit	40.00
---------	----------------------	-------

- THESE PRODUCTS ARE PACKAGED FOR OUTSTANDING WALL DISPLAY APPEARANCE

- FULL **FAIRCHILD** PRODUCT LINE TO FOLLOW

Satisfaction Guaranteed. \$5.00 Min. Order. U.S. Funds.
California Residents — Add 6% Sales Tax
Send a 24¢ Stamp (postage) for a Free 1977 Catalog

NOW OPEN SATURDAYS

JAMES

1021-A HOWARD AVE., SAN CARLOS, CA. 94070
PHONE ORDERS WELCOME — (415) 592-8097

- DEALER'S AND WHOLE-SALER'S INQUIRIES INVITED — PRICE LIST AVAILABLE.

- BUY WITH PRIDE THE PRODUCTS BUILT BY THE INDUSTRY'S

LEADER — **FAIRCHILD**

7400N TTL

SN7400N	.16	SN7400A	.25	SN74154N	1.00
SN7401N	.16	SN7402N	.22	SN74155N	.99
SN7402N	.21	SN7403N	.39	SN74156N	.99
SN7403N	.16	SN7404N	.39	SN74157N	.99
SN7404N	.16	SN7405N	.32	SN74160N	1.25
SN7405N	.24	SN7406N	.30	SN74161N	.99
SN7406N	.20	SN7407N	.30	SN74163N	.99
SN7407N	.29	SN7408N	.32	SN74164A	1.10
SN7408N	.25	SN7409N	5.00	SN74165N	1.10
SN7409N	.25	SN7410N	.98	SN74166N	1.10
SN7410N	.18	SN7412N	.60	SN74167N	5.50
SN7412N	.33	SN74125N	.89	SN74170N	2.10
SN74125N	.33	SN74126N	.89	SN74172N	8.95
SN7413N	.45	SN74127N	3.25	SN74173N	1.50
SN7414N	.40	SN74130N	2.50	SN74174N	2.25
SN74148N	.35	SN74131N	4.5	SN74175N	.99
SN7417N	.25	SN74132N	.49	SN74176N	.90
SN7420N	.21	SN74133N	.49	SN74177N	.90
SN7421N	.33	SN74134N	.49	SN74181N	2.49
SN7422N	.37	SN74135N	.49	SN74182N	.95
SN7423N	.37	SN74136N	.49	SN74183N	1.95
SN7424N	.29	SN74137N	7.00	SN74184N	2.20
SN7425N	.29	SN74138N	1.00	SN74186N	15.00
SN7426N	.29	SN74139N	.39	SN74187N	6.00
SN7427N	.37	SN74140N	.39	SN74188N	3.95
SN7428N	.37	SN74141N	.39	SN74189N	1.19
SN7429N	.37	SN74142N	.70	SN74190N	1.19
SN7430N	.26	SN74143N	.70	SN74191N	1.19
SN7431N	.26	SN74144N	4.50	SN74192N	.89
SN7432N	.26	SN74145N	1.15	SN74193N	.89
SN7433N	.21	SN74146N	60	SN74194N	1.25
SN7434N	.21	SN74147N	1.09	SN74195N	.75
SN7435N	.21	SN74148N	1.15	SN74196N	.75
SN7436N	.21	SN74149N	4.50	SN74197N	.75
SN7437N	.21	SN74150N	2.00	SN74198N	1.75
SN7438N	.21	SN74151N	2.00	SN74199N	1.75
SN7439N	.25	SN74152N	60	SN74200N	5.59
SN7440N	.15	SN74153N	.89	SN74201N	.90
SN7441N	.89	SN74154N	1.09	SN74202N	1.79
SN7442N	.59	SN74155N	1.15	SN74203N	6.00
SN7443N	.75	SN74156N	1.15	SN74204N	6.00
SN7444N	.75	SN74157N	4.50	SN74205N	6.00
SN7445N	.75	SN74158N	4.50	SN74206N	6.00
SN7446N	.81	SN74159N	2.00	SN74207N	6.00
SN7447N	.89	SN74160N	2.00	SN74208N	6.00
SN7448N	.79	SN74161N	2.50	SN74209N	6.00
SN7449N	.79	SN74162N	2.50	SN74210N	6.00
SN7450N	.26	SN74163N	1.00	SN74211N	1.79
SN7451N	.26	SN74164N	2.00	SN74212N	1.79
SN7452N	.27	SN74165N	2.00	SN74213N	1.79
SN7453N	.27	SN74166N	2.00	SN74214N	1.79
SN7454N	.20	SN74167N	2.00	SN74215N	1.79
SN7455N	.20	SN74168N	2.00	SN74216N	1.79
SN7456N	.20	SN74169N	2.00	SN74217N	1.79
SN7457N	.20	SN74170N	2.00	SN74218N	1.79
SN7458N	.20	SN74171N	2.00	SN74219N	1.79
SN7459N	.20	SN74172N	2.00	SN74220N	1.79
SN7460N	.20	SN74173N	2.00	SN74221N	1.79
SN7461N	.20	SN74174N	2.00	SN74222N	1.79
SN7462N	.20	SN74175N	2.00	SN74223N	1.79
SN7463N	.20	SN74176N	2.00	SN74224N	1.79
SN7464N	.20	SN74177N	2.00	SN74225N	1.79
SN7465N	.20	SN74178N	2.00	SN74226N	1.79
SN7466N	.20	SN74179N	2.00	SN74227N	1.79
SN7467N	.20	SN74180N	2.00	SN74228N	1.79
SN7468N	.20	SN74181N	2.00	SN74229N	1.79
SN7469N	.20	SN74182N	2.00	SN74230N	1.79
SN7470N	.20	SN74183N	2.00	SN74231N	1.79
SN7471N	.20	SN74184N	2.00	SN74232N	1.79
SN7472N	.20	SN74185N	2.00	SN74233N	1.79
SN7473N	.20	SN74186N	2.00	SN74234N	1.79
SN7474N	.20	SN74187N	2.00	SN74235N	1.79
SN7475N	.20	SN74188N	2.00	SN74236N	1.79
SN7476N	.20	SN74189N	2.00	SN74237N	1.79
SN7477N	.20	SN74190N	2.00	SN74238N	1.79
SN7478N	.20	SN74191N	2.00	SN74239N	1.79
SN7479N	.20	SN74192N	2.00	SN74240N	1.79
SN7480N	.20	SN74193N	2.00	SN74241N	1.79
SN7481N	.20	SN74194N	2.00	SN74242N	1.79
SN7482N	.20	SN74195N	2.00	SN74243N	1.79
SN7483N	.20	SN74196N	2.00	SN74244N	1.79
SN7484N	.20	SN74197N	2.00	SN74245N	1.79
SN7485N	.20	SN74198N	2.00	SN74246N	1.79
SN7486N	.20	SN74199N	2.00	SN74247N	1.79
SN7487N	.20	SN74200N	2.00	SN74248N	1.79
SN7488N	.20	SN74201N	2.00	SN74249N	1.79
SN7489N	.20	SN74202N	2.00	SN74250N	1.79
SN7490N	.20	SN74203N	2.00	SN74251N	1.79
SN7491N	.20	SN74204N	2.00	SN74252N	1.79
SN7492N	.20	SN74205N	2.00	SN74253N	1.79
SN7493N	.20	SN74206N	2.00	SN74254N	1.79
SN7494N	.20	SN74207N	2.00	SN74255N	1.79
SN7495N	.20	SN74208N	2.00	SN74256N	1.79
SN7496N	.20	SN74209N	2.00	SN74257N	1.79
SN7497N	.20	SN74210N	2.00	SN74258N	1.79
SN7498N	.20	SN74211N	2.00	SN74259N	1.79
SN7499N	.20	SN74212N	2.00	SN74260N	1.79
SN7500N	.20	SN74213N	2.00	SN74261N	1.79

CONSUMER ELECTRONICS

PONG SUPER PONG

SINGLE GAME \$55.00
4 GAMES IN ONE \$79.95

FOR YOUR HOME TV

GAMES INCLUDED IN SUPER PONG ARE:
• PONG • CATCH
• SUPER PONG • HANDBALL

FEATURES OF PONG AND SUPER PONG

- Incremental speed on volleys increases excitement.
- Playing field adjusts to any size screen.
- Game appears in color or in black & white, depending on television set.
- Unmistakable "PONG" sound accompanies each volley.
- Digital scoring flashes on the screen between each point.
- 2 player challenge of Solitaire.
- Hooks up simply to any home television set; the screen actually becomes the playing field.
- English and other techniques can be used to make any member of the family a Pong champion.
- Battery operated by 4 size "D" flashlight batteries included with the Unit.

AC Adaptor (Eliminates Batteries) \$9.95

DISCRETE LEADS

XC209	Red	10/51	XC111	Red	10/51
XC209	Green	4/51	XC111	Green	4/51
XC209	Orange	4/51	XC111	Orange	4/51

DISPLAY LEADS

DL707	Common Anode	270	2.95	MAN 3620	Common Anode-orange	.300	1.75
MAN 1	Common Anode	300	4.95	MAN 3610	Common Cathode-orange	.300	1.75
MAN 2	5 x 7 Dot Matrix	125	.39	MAN 3740	Common Cathode-red	.400	1.95
MAN 3	Common Cathode	187	1.95	DL707	Common Anode-red	.300	1.85
MAN 4	Common Cathode	300	1.25	DL704	Common Cathode	.300	1.50
MAN 7	Common Anode	300	1.95	DL707	Common Anode	.300	1.50
MAN 7G	Common Anode-green	300	1.95	DL 728	Common Cathode	.300	2.95
MAN 7Y	Common Anode-yellow	300	1.95	DL 747	Common Cathode	.600	2.25
MAN 64	Common Anode-green	400	1.75	DL 750	Common Cathode	.600	2.49
MAN 74	Common Anode	300	1.25	DL 338	Common Cathode	.110	.99
MAN 74	Common Cathode	300	1.50	FN070	Common Cathode	.250	.75
MAN 82	Common Anode-yellow	300	1.75	FN053	Common Cathode	.500	1.00
MAN 84	Common Cathode-yellow	.300	1.75	FN057	Common Anode	.500	1.00

MINIATURE TOGGLE

DPDT	ON	OFF	DN	AMT	1	2	4	10-20	30-60
	ON	OFF	DN	223	2.95	2.15	1.87	1.70	
	ON	OFF	DN	121	2.35	1.95	1.43	1.30	
	ON	OFF	DN	123	2.05	1.85	1.21	1.10	

PUSH BUTTON

PB-123 \$1.75
PB-126 \$1.75

SPOT - SERIES PB, PB1
Maintained Action Switch
Push To Make Contact - Auto
Push To Release or Auto
Momentary Action Switch
Normally Open to Normally
Closed. I.P.M. N.C. Contact use
terminals 2, 4, 1. Not D.O. 2
N.C. for N.C. and D.O. 1, 2, 3

THUMBWHEEL SWITCH ONLY

Part No.	Description	Price
SR-12	Single Pole 10 Position	.50
SR-12	Dual	3.00
SR-21	10 Position BCD only	1.00
SR-21	10 Position BCD only	3.00

ACCESSORIES

Part No.	Description	Price	Part No.	Description	Price
SR-EP	End Plate (each)	.50	SR-EP	End Plate (each)	5.50
SR-DP	Divider Plate (each)	.40	SR-DP	Divider Plate (each)	.40
SR-FB	Front Body (each)	.40	SR-FB	Front Body (each)	.40
SR-HB	Half Body (each)	.40	SR-HB	Half Body (each)	.40

DIP SWITCH

These switches feature seven SPST side switches in a molded dip. They are ideally suited for microprocessor applications.

\$1.95

CLIPLITE!! 4/\$1.00

NEW LED MOUNTING SYSTEM

- CLIPLITE mounts from the front of the Panel in a .250 hole on 3/8" centers. Panel thickness from 3/16" to 1/8".
- CLIPLITE equalizes and increases the brightness of commonly used wide beam LEDs.
- CLIPLITE is to be used with XC556 LEDs.
- Specify colors - red, green, amber, or yellow when ordering.

ZENERS - DIODES - RECTIFIERS

TYPE	VOLTS V	PRICE	TYPE	VOLTS V	PRICE
1N748	3.3	400m	4110	1N4005*	600 PIV 1 AMP 10/1.00
1N751A	5.1	400m	4110	1N4006*	800 PIV 1 AMP 10/1.00
1N752	5.6	400m	4110	1N4007*	1000 PIV 1 AMP 10/1.00
1N753	6.2	400m	4110	1N3600	50 200m 5/1.00
1N754	6.8	400m	4110	1N4148	75 10m 15/1.00
1N999	8.2	400m	8100	1N4154	35 10m 12/1.00
1N2558	15	400m	4110	1N4305	75 25mA 20/1.00
1N2532	5.6	500m	28	1N4734	5.6 1w 28
1N2534	6.2	500m	28	1N4735	6.2 1w 28
1N2535	6.8	500m	28	1N4736	6.8 1w 28
1N2536	7.5	500m	28	1N4737	7.5 1w 28
1N2538	25	40m	6100	1N4742	12 1w 28
1N4584	150	7m	6100	1N4744	15 1w 28
1N4584	180	10m	5100	1N1183	50 PIV 35 AMP 1.60
1N4001	50 PIV 1 AMP	12/1.00	1N1184	100 PIV 35 AMP 1.70	
1N4002	100 PIV 1 AMP	12/1.00	1N4130	100 PIV 1 AMP 1.50	
1N4003	200 PIV 1 AMP	12/1.00	1N1186	200 PIV 35 AMP 1.80	
1N4004	400 PIV 1 AMP	12/1.00	1N1188	400 PIV 35 AMP 1.30	

SCR AND FW BRIDGE RECTIFIERS

C38M	15A @ 400V	SCR	1.95
C38M	35A @ 200V	SCR	1.95
2N2328	1.6A @ 200V	SCR	.50
MDA 980-1	25A @ 50V	FW BRIDGE REC.	1.95
MDA 980-3	25A @ 200V	FW BRIDGE REC.	1.95

TRANSISTORS

MPS 405	\$51.00	PN3567	351.00	PN4249	451.00
MPS 406	\$51.00	PN3568	451.00	PN4240	451.00
2N2214	451.00	PN3569	451.00	PN4241	451.00
2N2222A	551.00	PN3704	551.00	PN4243	451.00
2N2939	551.00	PN3705	551.00	PN4249	451.00
2N2939A	551.00	PN3706	551.00	PN3686	451.00
PN2415	551.00	PN3707	551.00	PN3687	451.00
PN2929	451.00	PN3711	551.00	PN3688	451.00
PN2906A	551.00	PN3712	551.00	PN3689	451.00
PN2907A	551.00	PN3720	551.00	PN3128	551.00
PN2925	551.00	PN3721	551.00	PN3138	551.00
PN3053	251.00	PN3905	451.00	PN3209	551.00
PN3055	\$1.89	PN3906	451.00	PN3251	551.00
MR3955	11.25	PN3907	451.00	CY8683CR	451.00
PN3392	551.00	PN4014	351.00	PN4342	551.00
PN3398	551.00	PN4123	101.00	10673	1.75ea.

CAPACITOR

10 pF	05	04	03	.001uF	05	04	03	05	04	03
22 pF	05	04	03	.0047uF	05	04	03	05	04	03
47 pF	05	04	03	.01uF	05	04	03	05	04	03
100 pF	05	04	03	.022uF	06	05	04	06	05	04
220 pF	05	04	03	.047u						

The Technical Forum:

A Proposal for a Universal Prototyping Bus Structure

From time to time, BYTE receives extended letters on specific technical points, letters which don't quite constitute articles, yet certainly deserve some special treatment. As a place in the magazine for an ongoing discussion of technical issues — hardware or software, applications or machine design — The Technical Forum should provide some interesting reading. Readers are invited to submit opinions, react to published opinions, or start The Technical Forum off on a whole new direction of discussion.

We start the feature this month with an extended opinion provided by David Washburn, 22A University Rd, Brookline MA 02146. Subject: The proposal of a universal bus structure.

I would like to propose a universal prototype bus for experimenters. At first I wanted a universal bus, but I have come to realize that there are two types of computer enthusiasts. One type includes those who want to purchase a working well-thought-out system that includes BASIC and allows them to quickly build and turn on a working system and write programs in BASIC. Altairs, IMSAIs, Spheres, SWTPC 6800s and the like fill this need. This is what I wanted originally but as I looked into each system I found many shortcomings. The main problem with each system seemed to be its bus design. The Altair bus, while having lots of lines, is not easily expandable to 16 bits for data, requires an expensive edge connector for each card, and has some 8080 oriented control lines which are not available on other processors (nor are they needed). The Southwest Technical Products 6800 system bus is fully utilized with the exception of a few user defined lines, so expansion would be difficult here.

These processors are not (or so it seems) designed for the second type of enthusiast, the high performance systems hacker. It seems that a bus could be designed to be general enough to work with most processors and yet remain independent of any specific processor. Even Dr Suding, who

espouses processor independence, has some pretty processor specific points to his systems. There is a cost factor which also influences my thinking. A typical 4 K Altair compatible memory card kit costs \$140. If the 32 2102s cost \$2.50 each, then the memory alone costs about \$80. The rest of the card, the PC board and supporting electronics then cost about \$60. This is an overhead of about \$1.80 per memory chip. If the user has four 4 K cards he or she has invested \$240 for Altair bus specific designs, provided the memory chips are mounted in sockets. As new and more powerful processors are designed the user is not necessarily in a position to take advantage of these advancements. Adapters to new buses are possible, but this would require special PC cards and these could hardly cost less than \$50 or so.

For the first type of user, mainly interested in BASIC, applications and some games, the difference between an IBM/370 and an 8080 (both operated in a stand alone mode for comparisons) is speed. More efficient use of memory and a more powerful instruction set are not important to such a person because it will always be cheaper to add more memory to an existing system than to invest in a whole new system.

Thus I see a "universal bus system" to be aimed primarily at the person who wants to experiment with different processors and create special cards for peripherals with special functions.

I see the different processors as being more similar than different in their basic functioning. All must be able to address memory, send and receive data, and communicate with the outside world. If the differences can be handled on the processor card, then the same memory and IO cards can be shared by most processors. There are

It's all right here

Prompt service



BRIGAR electronics

In-depth inventories

ELECTRONICS for INDUSTRY

LOW, LOW PRICES!

Offices & Warehouse: 10 Alice Street, Binghamton, New York 13904 • Tel: 607-723-3111

SAVE

SAVE

PHONE ORDERS
607 723 3111

MINIATURE LAMPS

INCANDESCENT LAMPS

CHICAGO MINIATURE LAMPS #387

SAME AS #327 EXCEPT LONGER LIFE

28 volts. .04 amps. Bulb Style T-1-3/4 Mid-Flange Base. BRAND NEW BOXED, 100 per box. 40,000 pcs in stock.

PRICE SCHEDULE

1 - 99 .. 40¢ each 100 - up .. 35¢ ea.

NEON INDICATING GLOW LAMPS

NE-2 neon lamps, with dropping resistor to operate directly from 115 VAC. Nominal Watts - 1/17. T-2 Clear Bulb, wire terminals.

25,000 pcs in stock. Mfd by G.E. Co. 10¢ each up to 1000 pcs.

1000 pcs & up 7¢ each.

INDICATOR LIGHTS

BRITE GLO INCANDESCENT LAMPS

BRITE-GLO Incandescent Lamps

Ultraminaturized Series, 100,000 hr. life Versatile, low cost indicator lamp. Ideal for Stereo Amplifiers, Mobile Equipment, Instrumentation, Computer and Display Panels, Etc.

High temperature, T 1-3/4 lamps - Metal Base - Wire Terminals. Metal base increases light output and protects lamp from damage.

41, 685 pcs - 6.3 volts, 75 ma, 8" wire leads.

40,263 pcs - 6.3 volts, 200 ma, 13" wire leads.

DISCOUNT SCHEDULE

SALE 1 - 99 25¢ ea. 100-499 20¢ ea. 500-999 15¢ ea. 1000-UP 12¢ ea. SALE

BARGAINS PRECISION RESISTORS

These should be specified when used in a precision and critical application and power are needed. They are of the highest quality and are guaranteed to meet or exceed MIL-R-155.

BRAND NEW - FINEST QUALITY

QUAN	MFR	TOL. (%)	OHMS	WATTS	PRICE Each
10,686	T.I.	1	191	1/8	\$.04
3,000	Electra	1	191	1/8	.04
29,000	I R C	1	243	1/8	.04
75,000	T.I.	1	2.43K	1/8	.04
35,000	T.I.	1	909	1/4	.06
7000	T.I.	1	10	1/2	.07
3000	Electra	1	15.4	1/2	.07
5700	Electra	1	28	1/2	.07
7900	I R C	1	53.6	1/2	.07
7200	I R C	1	90.9	1/8	.04
6600	I R C	1	1650	1/8	.04
1800	I R C	1	6190	1/8	.04
1000	I R C	1	2670	1/8	.04

Computer Grade Capacitors

PHONE ORDERS
607 723 3111

Instant off-the-shelf delivery.

QUAN.	MFD.	VOLTS	SIZE	PRICE EA
350	30000	5	1-3/8 x 4-3/16	\$1.50
494	60000	5	3" x 4-1/2"	1.50
1016	25000	6	2-1/16" x 4-9/16"	1.50
527	40000	7	2" x 5"	1.50
353	15000	10	2" x 4-1/8"	1.25
869	15500	10	2" x 4-7/16"	1.25
277	40000	10	3" x 4-1/2"	1.70
316	74000	10	3" x 4-3/4"	2.00
375	15000	12	2" x 4-1/2"	1.25
267	14000	13	2" x 4-3/8"	1.25
600	10000	15	2-1/16" x 4-1/2"	1.25
529	12500	16	2" x 4-1/8"	1.25

Computer Grade Capacitors

MALLORY

PRICE SLASHED

CG (STANDARD) 85°C Supplied with PVC Insulating Sleeve

Quan.	Mfd.	Vdc	Size	Each
10000	1100	35	1-25/64 x 2-11/64	\$.75
25000	100	35	1-25/64 x 2-11/64	.50
10000	80	400	1-25/64 x 2-11/64	.60

POTTER & BRUMFIELD SUB-MINIATURE RELAYS

TYPE KH 5505 (Identical to KHU17D11)
COIL: 24vdc, 650 ohms.
CONTACTS: 4PDT, 3amps at 30vdc or 120 vac

Small rugged DC relay with clear polycarbonate dust cover. Contacts are gold flashed silver. Mounts by solder terminals or 3-48 stud 5/16" long. Also mounts as plug-in. 6500 pc in stock, BRAND NEW, while they last at this price. \$1.25 each

LAMINATED PHENOLIC PLASTIC PANELS

BRAND NEW PHENOLIC SHEETS

Grade LE- Natural
Type - FBE, Mil Spec: 15035, .062" thick
Needed by all experimenters, amateurs and radio men for insulating parts - terminal strips - building sets or for research & development, etc.

Stock # 550 - 6" x 6" x .062" 42¢ each
" # 551 - 6" x 12" x .062" 82¢ each
" # 553 - 12" x 12" x .062" \$1.58 ea
" # 554 - Full sheets 38" x 47" x .062" \$13.00 each.

BRAND NEW QUALITY SHEETS

High-Speed Reset Counter Veeder-Root

4 FIGURE COUNTER MANUAL RESET
115VDC 115VAC
VEEDER ROOT 172604

115VAC (Receiver supplied). Basic counter is 115VDC, 6 watta 4 figure black on white background. Push button reset. Dim: 1-7/8" width 1-1/8" high x 2-1/2" deep.

\$12.95

LIGHTED \$2.95 Each

PUSHBUTTON SWITCHES



Unit can be used on 6 v or in series for 12 volt SPST, mom, PC board gold plated pins for wiring or easy installation.
10,000 pcs in stock

Mfr: Grayhill Switch Co. Widely used on computers, machine tools, office machines, guidance control and a wide variety of applications.

SAVE

Electrolytic Capacitors

TUBULAR, HIGH RELIABILITY



QUAN.	MFD.	VDC	EACH	QUAN.	MFD.	VDC	EACH
600	100	3	.30	1055	30	350	\$1.00
375	250	3	.35	246	40	350	1.14
298	500	6	\$1.00	967	4	450	.98
299	1000	6	1.00	400	10	450	1.07
571	1200	6	1.02	529	15	450	1.07
375	1500	6	1.10	453	20	450	1.14
313	2000	6	1.11				
597	100	12	.60				
4000	50	15	.30				
26,000	200	15	.30				
416	1500	15	1.10				
350	2000	15	1.10	899	.1	100	\$.35
2500	10	25	.25	437	.33	100	.40
1161	2000	25	1.40	1360	.22	150	.40
2600	10	50	.40	820	.022	200	.35
1000	500	50	.80	4200	.033	200	.35
825	100	50	.95	400	.1	200	.40
1099	150	50	.90	771	1.0	200	.40
6549	250	50	.98	417	1.5	200	.40
1942	300	50	1.07	1100	.001	400	.35
10,500	60	150	.70	1100	.0022	400	.40
520	80	150	.90	1600	.022	400	.45
290	300	150	1.00	565	.047	400	.50
476	40	200	1.00	4000	.022	600	.25
409	100	250	1.39	389	.05	600	.30
284	200	250	1.50	500	.1	600	.30
255	5	350	.90	600	.2	600	.30
281	10	350	.90	717	.25	600	.30
20,000	4	250	.35	30,000	.01	100	.15
339	8	250	.70	1000	.047	100	.20
400	16	250	.60	291	.22	400	.30

METALLIZED PAPER FILM



HIGH POWER DUMMY LOAD

Mfg. Eastern Microwave. #10-1254...RF Coaxial Load Resistor utilizing water flow to cool and provide a load resistance of 50 ohms for inputs from DC to 4000 MHz. Maximum power input is 1000 watts. Requires a flow of .218 GPM min. per 100 watts of input power; 100 psi pressure. Compression fittings on water line inlet and outlet for copper tubing supply lines. Has a Flange type coaxial fitting, friction type, 13/16" I.D. with 2-1/4" flange. Completely shielded unit of machined aluminum. Size: 1-5/8" diameter by 5-3/8" long. Shipping weight, 2 lbs.

5,000 pcs in stock, NEW BOXED.....\$14.95 each.....



Cherry Electrical Products



These switches are postage stamp sized precision switches which feature long operating life & high electrical capacity for their size 5 amp, 1/4 HP, 125-250 vac, SPDT, quick dis-connect terminals. 2,000 pcs in stock without lever. 75¢ each 2,400 pcs in stock with extended roller lever. 95¢ ea

TANTALUM CAPACITORS

SPRAGUE

TYPE 109D

TUBULAR SINTERED-ANODE TANTALEX CAPACITOR #109D147X9060T2
1620 pcs - 140 uf ±10% - 60vdc \$2.00 ea.

GENERAL ELECTRIC PLAIN FOIL TANTALUMS -125°C (SEE CL33 INSTEAD OF CL32 THE MAJOR SHUNT CL33/33-POLARIZED)

3,000 pcs CL31BEL80MPE, 18uf - 15vdc 65¢ each
300 pcs CL31BES50MPE, 55uf - 15vdc 85¢ each non-polarized CL32/33
900 pcs CL33BL020MPE, 2.0uf - 75vdc \$1.00 each

MALLORY

MTP/MTPH ULTRA-MINIATURE TANTALUM CAPACITORS MTP TYPES
10,550 pcs MTP685M20P1D, 6.8uf - 20vdc 55¢ each
2,100 pcs MTP106M30P1A, 10uf - 30vdc 75¢ each
1,028 pcs MTP336M10P1A, 33uf - 10vdc 65¢ each

MALLORY

TAS SOLID ELECTROLYTE TANTALUM CAPACITORS
4996 pcs, 4.7uf ±10%, 6vdc, TAS475K006P1A 35¢ ea
394 pcs, .47uf ±10%, 6vdc, TAS474K006P1A 38¢ ea
1430 pcs, 47uf ±10%, 6vdc, TAS476K006P1C 40¢ ea
326 pcs, 220uf ±20%, 6vdc, TAS227M006P1G \$1.20 ea
285 pcs, 5.6uf ±10%, 10vdc, TAS565K010P1C 40¢ ea
4574 pcs, 10uf ±10%, 10vdc, TAS106K010P1C 40¢ ea
900 pcs, 15uf ±20%, 10vdc, TAS156M010P1C 40¢ ea
887 pcs, .068uf ±10%, 20vdc, TAS683K020P1A 51¢ ea
152 pcs, 2.2uf ±20%, 20vdc, Sprague 40¢ ea
1457 pcs, .47uf ±10%, 35vdc, TAS474K035P1A 51¢ ea

GENERAL ELECTRIC PLAIN FOIL TANTALUMS +125°C

365 pcs G.E. 40uf ±20%, 50vdc, 125°C Type: 2K105AA5M. \$1.75 each
1168 pcs SPRAGUE, 40uf, ±20%, 50vdc, 125°C Type: 220D005A3M. \$1.75 each

All Orders F.O.B. Binghamton, NY. Minimum Order \$5.00 NY State Residents please add sales tax

BRIGAR ELECTRONICS publishes a monthly flyer. If you want to be placed on our active mail list, send us your Name Address

other advantages; if the system works with a 6800 processor and the experimenter designs an SC/MP processor card, he or she knows that it is the only part of the system being tested. This allows the experimenter to isolate the area of the experiment that doesn't work when the inevitable bugs are detected.

Most important is the ability for people to share their ideas and projects. If such a system became popular enough, some of the basic cards developed with wire wrap might be converted to printed circuit boards. Memory cards, basic IO cards and prototyping cards are good candidates as well as some of the more common or well understood processors. Computer clubs could undertake the design and production of printed circuit cards if their members were interested in a particular design. The club could sell to the rest of the computer enthusiast world via other clubs as well. The electronic design could be published in magazines like BYTE so that many people would benefit from each person's work. If interest in such a bus were great enough then companies might be able to produce their products on compatible printed circuit cards.

Of course, standardization causes problems of its own. Some people will feel left out and others will find it less than optimal for one reason or another. But if the basics common to most processors can be extracted and some foresight on processor architectural changes is anticipated, then a useful system could be designed.

Some of the ideas I would like to include follow; I am sure everyone has his/her own ideas and I would be interested in hearing from each one. My own crystal ball is probably far from perfect. If there is enough response this idea might even catch on.

- Low cost connectors that are easily available. One possibility would be to use dual double contact 22 pin connectors, a standard size widely available, for a total of 88 contacts at the backplane.
- A minimum of 18 bits of addressing. The most significant bits would be ignored for the time being, tied low, but would be available when the time comes for processors which can address 128 K.
- Memory organization of 16 bits data width. For the time being, most processors are 8 bits wide; these can interface a 16 bit bus by relatively simple selection logic based on the low order bit and implemented on the processor card.

- 18 bit data bus. The extra two data-like lines (given a 16 bit memory) could be used for user defined functions such as parity checking with interrupt on error, read or write protect faults, etc; the system would be designed to default to operation which ignores these bits.
- Provisions for DMA and multi-processor priority adjudication. Multiple processors can be useful, as in the case where a 6800 micro is used to implement a file management system as a slave to (for example) a 9900 processor. Multiprocessing can be quite evolutionary in such a system; software written and reliably operating on one processor needn't be thrown out just because a new processor is on the system. Simply handing off control to the new processor gains its advantages for the programs which use them, while retaining the older software. With a true multiprocessor system (with independent, parallel processing), addition of new processors can improve the performance of the system within the memory bandwidth limits of the bus structure.
- A "speed code" number. Each memory board would place on the speed bus a number, for example, a 3 bit number, indicating the data ready delay. If 0 is 100 ns, then 7 would be 800 ns delay. The processor card would then have logic to digitally generate the required delays and slow down if necessary. A processor like the SC/MP would never see any delay, but a 6800 might slow down with any memory card that takes longer than a #6 value. A TMS9900 would slow down for any memory slower than a #5 value on the bus, etc.
- A standard set of IO addresses for common peripherals, located at an "intelligent" place in memory address space. The only problem here, however, is that the ideal place depends upon which computer one is dealing with. One solution is to dedicate a specific 256 byte block for IO use, and have standard low order address designations; the higher order page location of this block could then be switch selectable in hardware using standard hexadecimal rotary switches which plug into DIP sockets.

I hope some other people are interested in defining such a structure. With enough interest we might get a "Universal Prototype Bus Newsletter" going. ■

Programming Quickies:

6800 Anti Wipeout Procedure

Charles C Worstell
36012 Military Rd S
Auburn WA 98002

This program may deter wiping out a program or parts of a program inadvertently in systems which use an SWI instruction to return to the monitor.

It is to be used immediately after turning the computer on. It puts a 3F (Software Interrupt) instruction in all addresses designated. It may be relocated to any appropriate location, and the second and third command changed as appropriate.

The program as given puts a 3F in a block

of programmable memory starting at 0080. It stops when there is no more programmable memory available in a continuous sequence. For instance, I have programmable memory at A000 but not at 9000. This program would not put 3F in A000. To do this, I would have to change the program with the second and third instruction being the location 9FFF.

I start at 0080 because addresses 0060 to 007F are used by the stack in my computer.

Don't put this program in a location such that it will wipe itself out.

While this program is not a cure-all, it will often save a program from being wiped out by an errant instruction sequence.

0000	CE 00 7F	START	LDX	#FIRSTADR	X :=FIRSTADR;
0003	86 3F		LDAA	#SWI	Initialize SWI op code in A;
0005	A7 01	NEXT	STAA	1,X	@(X+1):= A [store SWI in memory at X+1];
0007	08		INX		X := X + 1;
0008	A1 00		CMPA	0,X	is A = @X [check for valid memory write]?
000A	27 F9		BEQ	NEXT	if so then keep loop going;
000C	3F		SWI		else return to monitor;

ZILOG Z-80 CPU CHIP IN STOCK! \$75.00 (MANUAL INCLUDED)

The "last word" in 8 bit CPU's. You've read and heard about this fantastic chip with its tremendous power and versatility. 158 different instructions including all 78 of the 8080A. Superior software features include relative addressing, block data transfer and search, BCD digit rotate, etc. Superior hardware features include single phase TTL compatible clock, high clock frequency, no expensive support chips (like 8212, 8224) are required, on chip dynamic memory refresh circuitry. If you are thinking about building your own computer from scratch then this is the chip to use.

LIMITED QUANTITY - FIRST COME FIRST SERVED

Z-80 TECHNICAL MANUAL

The whole story, inside and out, on the Zilog Z-80. Includes complete explanation of the Z-80's expanded instruction set.

\$7.50

PS: If you are thinking about buying an IMSAI or ALTAIR compatible Z-80 CPU Board then WAIT! At least until next month when S. D. Sales will announce its next kit. It's worth waiting for!

S.D. SALES CO. P. O. BOX 28810 B DALLAS, TEXAS 75228

S. D. SALES CO.

P. O. BOX 28810 B
DALLAS, TEXAS 75228

4K LOW POWER RAM BOARD KIT THE WHOLE WORKS \$89.95

Imsai and Altair 8080 plug in compatible. Uses low power static 21L02-1 500 ns. RAM's, which are included. Fully buffered, drastically reduced power consumption, on board regulated, all sockets and parts included. Premium quality plated thru PC Board.

Stick It!

IN YOUR CLOCK!
IN YOUR DVM, etc.

HUGE SPECIAL PURCHASE!
NOT FACTORY SECONDS
AS SOLD BY OTHERS

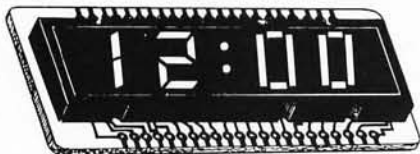

4 JUMBO .50 INCH DIGITS
ON ONE "STICK"!
(with colons and AM/PM Indicator)

\$3.95

BUY 3 FOR \$10.00

BOWMAR

4 DIGIT LED READOUT ARRAY

The Bowmar Opto-Stick. The best readout bargain we have ever offered. Has four common cathode jumbo digits with all segments and cathodes brought out. Increased versatility since any of the digits may be used independently to fit your applications. Perfect for any clock chip, especially direct drive units like 50380 or 7010. Also use in freq. counters, DVM's, etc. For 12 or 24 hour format.

MICROPROCESSORS AND THINGS

8080A	By AMD. Outperforms INTEL	\$24.00
8008-1	High Speed 8008	6.95
8212	I/O PORT	3.50
8224	Clock Generator	4.95
8820	Dual Line RCVR	1.75
8830	Dual Line Driver	1.75
8838	Quad Bus Transceiver	2.00
MC1488	RS232 to TTL	1.50
MC1489	TTL to RS232	1.50
2513	Character Gen.	10.00
MM5204	4K E Prom	12.00

*LOW COST
HIGH VALUE*

TTL INTEGRATED CIRCUITS

7400 - 19c	7430 - 19c	7476 - 35c	74153 - 75c
7402 - 19c	7432 - 34c	7480 - 49c	74154 - 1.00
7404 - 29c	7437 - 39c	7483 - 95c	74157 - 75c
74504 - 44c	7438 - 39c	7485 - 95c	74161 - 95c
7404 - 19c	7440 - 19c	7586 - 45c	74164 - 1.10
7406 - 29c	7447 - 85c	7490 - 65c	74165 - 1.10
7408 - 19c	7448 - 85c	7492 - 75c	74174 - 95c
7410 - 19c	7451 - 19c	7495 - 75c	74181 - 2.50
7411 - 29c	7453 - 19c	7496 - 89c	74191 - 1.25
7413 - 50c	7473 - 39c	74121 - 38c	74192 - 1.25
7420 - 19c	7474 - 35c	74123 - 65c	74193 - 1.00
	7575 - 35c	74141 - 75c	74195 - 69c

2/\$10. 60HZ CRYSTAL TIME BASE FOR DIGITAL CLOCKS S.D. SALES EXCLUSIVE! **\$5.95**

KIT FEATURES:

- 60hz output with accuracy comparable to a digital watch
- Directly interfaces with all MOS Clock Chips
- Super low power consumption (1.5 Ma typ.)
- Uses latest MOS 17 stage divider IC
- Eliminates forever the problem of AC line glitches
- Perfect for cars, boats, campers, or even for portable clocks at ham field days.
- Small size, can be used in existing enclosures.

KIT INCLUDES CRYSTAL, DIVIDER IC, PC BOARD PLUS ALL OTHER NECESSARY PARTS & SPECS.

JUMBO LED CAR CLOCK

**\$16.95
KIT**

You requested it! Our first DC operated clock kit. Professionally engineered from scratch to be a DC operated clock. Not a makeshift kluge as sold by others. Features: Bowmar 4 digit .5 inch LED array, Mostek 50252 super clock chip, on board precision time base, 12 or 24 hour real time format, perfect for cars, boats, vans, etc. Kit contains PC Board and all other parts needed (except case). 50,000 satisfied clock kit customers cannot be wrong!

FOR ALARM OPTION ADD \$1.50

FOR XFMR FOR AC OPERATION ADD \$1.50

50 HZ CRYSTAL TIME BASE KIT - \$6.95

All the features of our 60HZ kit but has 50HZ output. For use with clock chips like the 50252 that require 50HZ to give 24 hour time format.

UP YOUR COMPUTER!

21L02-1 1K LOW POWER 500 NS STATIC RAM TIME IS OF THE ESSENCE

And so is power. Not only are our RAM's faster than a speeding bullet but they are now very low power. We are pleased to offer prime new 21L02 - 1 low power and super fast RAM's. Allows you to STRETCH your power supply farther and at the same time keep the wait light off.

8 for \$12.95

1000 MFD FILTER CAPS

Rated 35 WVDC. Upright style with PC leads. Most popular value for hobbyists. Compare at up to \$1.19 each from franchise type electronic parts stores.



S.D. Special
4 for \$1.00

WESTERN DIGITAL UART No. TR1602B, 40 pin DIP

This is a very powerful and popular part.

**NEW-\$6.95 with data
LIMITED QUANTITY**

C&K MINI TOGGLE SWITCH No. 7103 SUB MINI SPDT Center OFF.

SPECIAL - 99c

SLIDE SWITCH ASSORTMENT



Our best seller. Includes miniature and standard sizes, single and multi-position units. All new, first quality, name brand. Try one package and you'll reorder more. **SPECIAL 12/\$1.**

MOTOROLA POWER DARLINGTON

Back in Stock!
Like MJ3001. NPN 80V. 10A. HFE 6000 TYP. TO-3 case. We include a free 723 C volt reg. with schematic for power supply. **SPECIAL - \$1.99**

RESISTOR ASSORTMENT

1/4 W 5% and 10%. PC leads. A good mix of values. **200/\$2.**



74S200

256 Bit High Speed RAM
Same as 82S16
\$3.95

1K PROM BACK IN STOCK!

82S129. 256x4. Bipolar, 50NS.
FAST. WITH SPECS.
\$3.95

FAIRCHILD BIG LED READOUTS

A big .50 inch easy to read character. Now available in either common anode or common cathode. Take your pick. Super low current drain, only 5MA per segment typical. FND-510 Common Anode FND-503 Common Cathode **PRICE SLASHED! 59c each**

SALE ON CUT LEAD SEMICONDUCTORS

Leads were cut for PCB insertion. Still very useable. All new, unused. Some House no.

1N914/1N4148 100/\$2.
1N4002 1 Amp 100 PIV 40/\$1.
1N4745A 16V 1W Zener 20/\$1.
EN2222 NPN Transistor 25/\$1.
2N3392 GE Pre-amp Xstr 25/\$1.
C103Y SCR, 800MA 60V 10/\$1.

**CALL YOUR BANK
AMERICARD OR MASTER
CHARGE ORDER IN ON
OUR CONTINENTAL
UNITED STATES TOLL
FREE WATTS:**

1-800-527-3460
Texas Residents Call Collect
214/271-0022

S.D. SALES CO.
P. O. BOX 28810 - B
Dallas, Texas 75228

TERMS:
Money Back Guarantee. No COD. Texas Residents add 5% tax. Add 5% of order for postage and handling. Orders under \$10. add 75c. Foreign orders: US Funds ONLY!

World's Lowest IC Prices

* SPECIAL PRICES *

MEMORIES	
<u>Rams</u>	
2102	1.50 *
<u>Proms</u>	
82S23/S123	1.95 *
TTL	
7400	.12 *
7402	.14
7403	.14 *
7404	.16 *
7407	.20
7410	.12 *
7420	.12 *
7427	.25
7438	.20 *
7440	.12 *
7441	.65 *
7445	.45
7447	.75
7450	.14
7451	.14 *
7473	.22
7474	.23
7480	.40 *
7493	.50
7495	.49
74107	.29
74109	.30
74116	1.50
74123	.45 *
74141	.80 *
74145	.75
74150	.60 *
74151	.60

74152	.90
74155	.60
74157	.60
74160	.75
74161	.75 *
74163	.75 *
74165	.80
74173	1.25
74174	.75
74175	.75 *
74177	.70
74180	.80
74181	1.50
74192	.70 *
74193	.70 *
74194	.85
74198	1.25
9602	.50 *
9300	.75
9312	.70
SCHOTTKY	
74S01	.25
74S02	.25
74S37	.40
74S38	.60
74S85	2.00
74S113	.80
74S139	1.50
74S140	.50
74S153	2.50
74S172	4.50
74S174	2.05
74S175	2.05 *
74S181	4.50
74S197	2.20
74S257	1.50

HIGH SPEED	
74H00	.20
74H01	.20
74H04	.20
74H10	.20
74H11	.20
74H40	.20
74H51	.20
74H52	.20
74H74	.40
74H103	.50
74H106	.50
LOW POWER SCHOTTKY	
74LS00	.29
74LS02	.29
74LS08	.29
74LS10	.29
74LS27	.30
74LS73	.45
74LS75	.65
74LS151	1.10
74LS153	1.10
74LS157	1.10
74LS161	1.50 *
74LS163	1.50
74LS164	1.50
74LS174	1.10 *
74LS175	1.50
74LS193	1.50
74LS221	1.50 *
74LS251	1.50
74LS253	1.50
74LS257	1.50
74LS258	1.50
CMOS	
4001	.16 *
4002	.16
4006	.90

4007	.16
4008	.70
4011	.16 *
4012	.16 *
4013	.30 *
4015	.80
4016	.35 *
4019	.70
4020	.90
4021	.95
4023	.16 *
4024	.75
4025	.20 *
4027	.40
4028	.60
4030	.35
4040	.95
4042	.60
4043	.75
4044	.70
4049	.35 *
4050	.35 *
4066	.65
4068	.35
4069	.16
4071	.16
4073	.16
4075	.16
4516	.85
4528	.75
4585	.85
LINEARS	
NE536T	2.75
NE555V	.43
NE556A	.90
1456V	.75
1458V	.52
566V	1.25
567V	1.35
540L	2.00

Order Minimum \$10.00. Add \$1.00 shipping and handling charge per order. California residents add 6% sales tax. All orders shipped First Class within 24 hours.

Order the famous lasis 6 volume Programmed Learning Course "Microcomputer Design is a Snap" for \$99.50 and receive a special \$10.00 credit on any group of IC's.

Satisfaction 100% guaranteed.

C.O.D. Orders: Phone (day or night) 408/354-1448

ELTRON

PO BOX 2542
Sunnyvale, CA 94087

Free monthly catalog—Just send us your name and address

DELTA ELECTRONICS CO

POST OFFICE BOX 2 70 OAKLAND ST AMESBURY, MASS 01913



VIA TRON TAPE HEADS
STOCK NO. 6435 \$6.95

XEROX

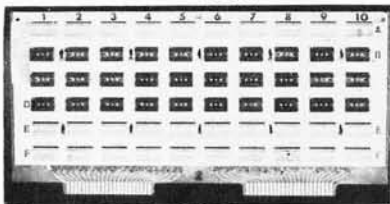

These are prototype boards that can be used in almost any type of wirewrap application. The board consists of a (top) positive plane and the other side is a negative plane. There are two 44 pin connectors that may be utilized. There are 30 16 pin sockets and 30 14 pin sockets. All these pins are gold plated. The wire wrapping that is in the back can very easily be removed. We have a limited quantity of these boards. so act quickly.
STOCK NO. P6434 \$27.50 2/50.00

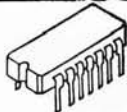

Dual In-Line

INTERGRATED CIRCUITS SERIES 74...0% C to 70% C

TYPE	FUNCTION	STK NO	PRICE
SN7400	Quad 2 input NAND gate	M3071	.20
SN7401	Quad 2 input NAND gate	M3081	.20
SN7402	Quad 2 input positive NOR gate	M3067	.20
SN7403	Quad 2 input positive NAND gate	M3065	.20
SN7404	Hex Inverter	M3123	.25
SN7407	Hex Buffer/ Drivers, 30 volt output	M3124	.40
SN7408	Quad 2 input AND gate	M3125	.25
SN7409	Quad 2 input AND gate, Open collector	M3126	.35
SN7410	Triple 3 input NAND gate	M3127	.25
SN75H11	Triple 3 input AND gate	M3136	.25
SN7413	Dual NAND Schmitt trigger	M3128	.75
SN7420	Dual 4 input positive NAND gate	M3088	.20
SN7430	8 input positive NAND gate	M3129	.35
SN7432	Quad 2 input positive OR gate	M3130	.35
SN7440	Dual 4 input positive NAND buffer	M3131	.20
SN7442	BCD to Decimal decoder	M3043	.65
SN7448	BCD to 7 segment decoder driver	M3120	.75
SN7470	J-K Flip-Flop	M3041	.50
SN7474	Dual D, Edge triggered Flip-Flop	M3073	.50
SN7475	Quad bistable latch	M3059	.75
SN7476	Dual J-K Master-Slave Flip-Flop	M3132	.50
SN7479	Dual Type D Flip-Flop	M3110	.50
SN7486	Quad 2 input Exclusive OR gate	M3133	.50
SN7490	Decade Counter	M3044	.75
SN74107	Dual J-K Master-Slave Flip-Flop	M3134	.50
SN74121	Monostable Multivibrator	M3121	.75
SN74193	Synchronous 4 bit UP/DOWN counter	M3093	1.00

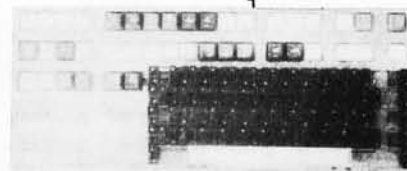

KEYBOARD KIT

This very unusual keyboard kit is made by Micro Switch. It has a set of switches & space bar in a modular frame, plus 42 molded double-shot keys in red, white, or blue. There are 8 control keys in addition to letters, numbers, & many symbols. The switches are arranged in 4 rows, but are easily removed or moved to other positions. This makes for a very versatile keyboard, since any number and type of key can be arranged in any pattern to suit your own needs. Any type of encoding can be wired. Finished size is 9 3/4" x 3 3/4" x 2".

STOCK NO. B6015 Keyboard Kit 2 1/2 lbs. \$19.95 ea. 2/35.00

KEYTOPS & SWITCHES



We have a large selection of KEYTOPS and SWITCHES, made by RAYTHEON CO. The keytops come in black, grey and white, with contrasting legends. The switches mate with the tops, and are magnetic reed switches. The following combinations are available:

54 key typewriter set, keys only, black	K9276	2.95
54 key typewriter set, keys only, grey	K9278	2.95
54 key TTY set, no symbols, white	K9279	2.95
54 key TTY set, with symbols, white	K9282	2.95
54 key set, keys & switches, black	K9288	30.00
54 key set, keys & switches, grey	K9290	30.00
54 TTY set, no symbols keys & Sw. White	K9291	30.00
54 TTY set, with symbols, keys & Sw. white	K9291	30.00
11 Key Numeric set, Keys only, Black	K9283	1.50
11 Key Numeric set, Keys only, Grey	K9284	1.50
11 Key Numeric set, Keys only, White	K9295	1.50
12 Key numeric set, Keys only, white	K9286	1.50
11 Key Num. set, keys & switches, Black	K9293	7.00
11 Key Num. set, keys & switches, Grey	K9294	7.00
11 Key Num. set, keys & switches, White	K9295	7.00
12 Key Num. set, keys & switches, white	K9296	7.50

SOPHISTICATED LINEAR PARTS BOARDS

This dual channel wide-band amplifier is loaded with late model parts. It has 2 ea. 733 differential video amps Lm301 op amps, Mc 1414 dual differential comparators (dual 710's), CA 3083 NPN DIP transistor arrays, Md2219 dual high speed NPN transistors, 9624 dual interface converters, 74123 dual one shots, and (4) 7400's. Also (6) trim pots, capacitors, transistors and many precision resistors and 1/4 watt resistors. One of the best sources of parts we have ever offered.
STOCK NO. P5442 11b \$3.50 2/6.00

Philbrick/ Nexus OPERATIONAL AMPLIFIER

Philbrick/Nexus Model SQ-10A is a high gain, high stability general purpose amplifier. It operates over the temp. range at -25 degrees C to 385 degrees C. Both inputs and output are fully protected against shorts to ground or the power supply. It may be used open loop as a voltage crossing detector. 1MHz unity gain bandwidth. Open loop gain 60,000 min. Slew rat 1.1v/sec. min. 100nA. max. input bias current. Nominal power plus or minus 15v.
STOCK NO. P4539 \$1.75 4/6.00

SEND FOR OUR LATEST FREE CATALOG! WE WELCOME MASTER CHARGE AND BANK AMERICAN. WE MUST HAVE ALL THE NUMBERS ON THE CARD FOR PROCESSING. PLEASE INCLUDE SUFFICIENT POSTAGE (2lbs) min. EXCESS WILL BE REFUNDED! minimum order \$5.00



SOLID STATE SALES

PO BOX 74B

SOMERVILLE, MASS. 02143

WE ARE LEADING THE WAY IN CUSTOMER SERVICE AND DELIVERY TIME FOR THE COST CONSCIOUS SEMI-CONDUCTOR USER, LARGE OR SMALL.

DIODES

TRANSISTORS

TRIACS

INTEGRATED CIRCUITS

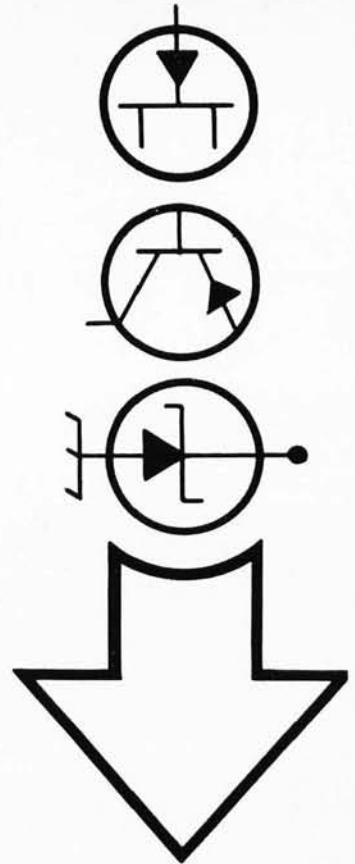

2522 STAT SR	\$2.75
INTEL 8080 CPU	\$24.50
2518-HEX 32 BIT SR	\$5.00
2102-1 1024 BT RAM	\$1.80
5280-4K DYNAMIC RAM	\$12.50
5202A UV PROM	\$12.50
MM5203 UV PROM	\$12.50
1702A UV PROM	\$10.75
5204-4K PROM	\$24.95
MINIATURE MULTI-TURN TRIM POTS 100, 500, 2K, 5K, 10K, 100K, 200K	\$3.52/100
MULTI-TURN TRIM POTS Similar to Bourms 3010 style 3/16"x5/8"x1-1/4", 50, 100, 1K, 10K, 50K ohms	\$1.50 ea.
LIGHT ACTIVATED SCR's TO-18, 200V 1A	\$1.75

TRANSISTOR SPECIALS

2N3585 NPN Si TO-66	\$.95
2N3772 NPN Si TO-3	\$ 1.60
2N4908 PNP Si TO-3	\$ 1.00
2N6056 PNP Si TO-3 Darlington	\$ 1.70
2N5086 PNP Si TO-92	4/\$ 1.00
2N4898 PNP TO-66	\$.80
2N404 PNP GE TO-5	\$ 1.00
2N3919 NPN Si TO-3 RF	\$ 1.50
MPSA 13 NPN Si TO-92	3/\$ 1.00
2N3767 PNP Si TO-66	\$.70
2N2222 NPN Si TO-18	5/\$ 1.00
2N3055 NPN Si TO-3	\$.80
2N3904 NPN Si TO-92	5/\$ 1.00
2N3906 PNP Si TO-92	5/\$ 1.00
2N5296 NPN Si TO-220	\$.50
2N6109 PNP Si TO-220	\$.55
2N3638 PNP Si TO-5	5/\$ 1.00
2N6517 NPN TO-92 Si	3/\$ 1.00

CMOS (DIODE CLAMPED)

74C02	-.22	4015	-.95	4035	-1.10
74C10	-.22	4016	-.40	4042	-.78
4001	-.22	4017	-1.05	4047	-2.00
4002	-.22	4018	-1.00	4049	-.40
4006	-1.20	4019	-.22	4050	-.40
4007	-.22	4022	-.95	4066	-.80
4009	-.42	4027	-.40	4071	-.22
4010	-.42	4028	-.88	4076	-.70
4011	-.22	4029	-1.10	4081	-.22
4012	-.22	4030	-.22	4520	-1.15
4013	-.40				

LED READOUTS

FND 500-5" C.C.	\$1.95
HP 7740-3" C.C.	\$1.40
MAN-7.3" C.A.	\$1.25
NS 33-3 dig. array	\$1.35
DL 747	\$2.50

Send 25¢ for our catalog featuring Transistors and Rectifiers
145 Hampshire St., Cambridge, Mass.

PRINTED CIRCUIT BOARD

4 1/2" x 6 1/2" SINGLE SIDED EPOXY BOARD 1/16" thick, unetched
5/\$2.20
VECTOR BOARD 1" SPACING
4.5" x 6" SHEET \$1.25

7 WATT LD-65 LASER DIODE \$8.95

2N 3820 P FET	\$.45
2N 5457 N FET	\$.45
2N 4891 UJT	\$.45
TIS 43 UJT	\$.35
ER 900 TRIGGER DIODES	4/\$1.00
2N 6028 PROG. UJT	\$.65

VERIPAX PC BOARD

This board is a 1/16" single sided paper epoxy board, 4 1/2" x 6 1/2" DRILLED and ETCHED which will hold up to 21 single 14 pin IC's or 8, 16, or LSI DIP IC's with buses for power supply connector. \$4.00

MV 5691 YELLOW-GREEN BIPOLAR LED	\$1.25
FP 100 PHOTO TRANS.	\$.50
RED, YELLOW, GREEN OR AMBER LARGE LED's	ea. \$.20
14 PIN DIP SOCKETS	\$.25
16 PIN DIP SOCKETS	\$.28
MOLEX PINS	100/\$1.00
8 PIN MINI DIP SOCKETS	\$.25
10 WATT ZENERS 3.9, 4.7, 5.6, 6.2, 12, 15, 18, 22, 100, 150 or 200V	ea. \$.60
1 WATT ZENERS 4.7, 5.6, 10, 12, 15, 18 OR 22V	ea. \$.25

Silicon Power Rectifiers

PRV 1A	3A	12A	50A	125A
100 .06	.14	.30	.80	3.70
200 .07	.20	.35	1.15	4.25
400 .09	.25	.50	1.40	6.50
600 .11	.30	.70	1.80	8.50
800 .15	.35	.90	2.30	10.50
1000 .20	.45	1.10	2.75	12.50

SILICON SOLAR CELLS

2 1/2" diameter
.4V at 500 ma. . . \$5.00 ea., 6/\$27.50

REGULATED MODULAR POWER SUPPLIES

+15 VDC AT 100ma	\$27.95
115VAC INPUT	\$27.95
5VDC AT 1A, 115VAC INPUT	\$24.95
12 VDC AT 5 AMP	\$24.95
IN 4148 (IN914)	15/\$1.00

TANTALUM CAPACITORS

22UF 35V 5/\$1.00	4.7UF 35V 4/\$1.00
47UF 35V 5/\$1.00	6.8UF 35V 3/\$1.00
68UF 35V 5/\$1.00	22UF 35V \$.40
1UF 35V 5/\$1.00	33UF 35V \$.40
2.2UF 20V 5/\$1.00	30UF 6V 5/\$1.00
3.3UF 35V 4/\$1.00	100UF 35V \$.50
M7001 ALARM CLOCK CHIP	\$6.00

NATIONAL MOS DEVICES

MM1402 - 1.75	MM5057 - 2.25
MM1403 - 1.75	MM5058 - 2.75
MM1404 - 1.75	MM5060 - 2.75
MM5013 - 2.50	MM5061 - 2.50
MM5016 - 2.50	MM5555 - 4.75
MM5017 - 2.70	MM5556 - 4.75
MM5055 - 2.25	MM5210 - 1.95
MM5056 - 2.25	MM5260 - 1.75

TTL IC SERIES

7400 - 14	7442 - 52	74125 - 40
7401 - 14	7445 - 70	74126 - 40
7402 - 14	7446 - 70	74151 - 70
7403 - 14	7447 - 70	74153 - 65
7404 - 18	7448 - 70	74154 - 110
7405 - 18	7450 - 70	74155 - 70
7406 - 20	7472 - 30	74157 - 70
7407 - 25	7473 - 30	74161 - 85
7408 - 21	7474 - 30	74164 - 95
7409 - 21	7475 - 49	74165 - 105
7410 - 15	7476 - 35	74173 - 140
7411 - 20	7480 - 35	74174 - 95
7412 - 20	7483 - 70	74175 - 92
7413 - 45	7485 - 88	74177 - 79
7414 - 70	7486 - 30	74188 - 70
7416 - 25	7489 - 1.85	74181 - 2.10
7417 - 25	7490 - 45	74190 - 1.20
7420 - 20	7491 - 70	74191 - 1.20
7425 - 28	7492 - 50	74192 - 85
7426 - 25	7493 - 45	74193 - 85
7427 - 30	7494 - 70	74194 - 85
7430 - 20	7495 - 70	74195 - 75
7432 - 25	7496 - 70	74196 - 88
7437 - 25	74107 - 32	75324 - 1.75
7438 - 25	74121 - 35	75491 - 65
7440 - 16	74123 - 65	75492 - 65
7441 - 85		

MINIATURE DIP SWITCHES

CTS-206-4 Four SPST switches in one minidip package	\$1.75
CTS-206-8 Eight SPST switches in a 16 pin DIP package	\$2.85

AY-5-1013-A30K ser./par., par./ser., universal UART	\$6.95
---	--------

ALCO MINIATURE TOGGLE SWITCHES	
MTA 106 SPDT	\$1.20
MTA 206 DPDT	\$1.70

Full Wave Bridges

PRV	2A	6A	25A
200	.95	1.25	2.00
400	1.15	1.50	3.00
600	1.35	1.75	4.00

SANKEN AUDIO POWER AMPS
Si 1010 G 10 WATTS \$ 6.90
Si 1020 G 20 WATTS \$13.95
Si 1050 G 50 WATTS \$24.95

CCD 110 LINEAR 256 X1 BIT SELF SCANNING CHARGED COUPLED DEVICE \$99.00
CCD 201 100 x 100 CHARGE COUPLED DEVICE \$135.00

LINEAR CIRCUITS

LM307 - Op. Amp.	\$.30
LM 309K 5V 1A REGULATOR	\$1.15
723 - 40 + 40V V REGULATOR	\$.50
301/748-Hi Per. Op. Amp.	\$.31
320T 5, 12, 15, or 24V NEG REG	\$1.50
709C - Op. Amp.	\$.31
741A or 741C OP. AMP.	\$.31
710 COMPARATOR	\$.35
CA 3047 Hi Per. Op. Amp.	\$1.50
340T 5, 6, 8, 12, 15, 18, 24V POS REG. TO-220	\$.95
101 OPER. AMP. HI PERFORM.	\$.75
LM 308 Oper. Amp., Low Power	\$.95
747 - DUAL 741	\$.65
555 - DUAL TIMER	\$1.00
537 - PRECISION OP. AMP.	\$1.70
LM 3900 - QUAD OP. AMP	\$.49
LM 324 - QUAD 741	\$1.50
560 - PHASE LOCK LOOP	\$2.00
561 - PHASE LOCK LOOP	\$2.00
565 - PHASE LOCK LOOP	\$1.25
566 FUNCTION GEN.	\$1.65
567 - TONE DECODER	\$1.50
LM 1310N FM STEREO DEMOD.	\$2.75
8038 IC VOLTAGE CONT. OSC.	\$3.90
LM 370 - AGC SOULCH AMP.	\$1.15
565 - 2ns - 2 HR. TIMER	\$.45
563 QUAD TIMER	\$2.50
FCD 810 OPTO-ISOLATOR	\$.80
1458 DUAL OP. AMP.	\$.60
LM 380 - 2W AUDIO AMP.	\$.95
LM 377 - 2W Stereo Audio Amp.	\$2.50
LM 381 - STEREO PREAMP.	\$1.50
LM 382 - DUAL AUDIO PREAMP	\$1.50
LM 311 - HI PER. COMPARATOR	\$.90
LM 319 - Dual Hi Speed Comp.	\$1.25
LM 339 - QUAD COMPARATOR	\$1.50

TRIACS SCR'S

PRV	1A	10A	25A	1.5A	6A	35A
100	.40	.70	1.30	.40	.50	1.20
200	.70	1.10	1.75	.60	.70	1.60
400	1.10	1.60	2.60	1.00	1.20	2.20
600	1.70	2.30	3.60	1.50	3.00	

Terms: FOB Cambridge, Mass.
Send Check or Money Order.
Include Postage, Minimum
Order \$5.00, COD \$20.00



SOLID STATE SALES

P.O. BOX 74B
SOMERVILLE, MASS. 02143 TEL. (617) 547-4005

WE SHIP OVER 95%
OF OUR ORDERS THE
DAY WE RECEIVE THEM

WHO DARED TO CHALLENGE THE 8080 & 6800 SYSTEMS?

WE DID!

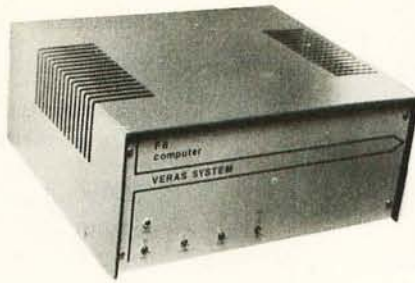

7" x 16" x 14-3/4"

VERAS SYSTEMS "F-8"

A COMPLETE SYSTEM
FOR ONLY \$459.00 KIT FORM

\$709.00 ASSEMBLED and TESTED

COMPARE STANDARD FEATURES ON BASIC SYSTEMS

YOU'LL SEE WHY THE VERAS F-8 SYSTEM WINS HANDS DOWN! *Registered Trademarks of Fairchild and Motorola

STANDARD FEATURES	VERAS F8	8080 & 8080A SYSTEMS	6800 SYSTEM
Parallel I/O Ports	(3) 8 Bit Bidirectional Brought Out To Rear Panel Conn's.	None	None
Serial I/O Port	RS-232 or TTY Brought Out To Rear Panel Term. Strip.	None	RS-232 or TTY
Interval Timers	(2) Programmable Interval Timers	None	None
Interrupts	a) Vectored Interrupt To Location 0090 Hex. b) Vectored Interrupt Programmable Location c) Two Vectored Interrupts Associated With Interval Timers d) Total of (4) Interrupts In A User Defined Priority Interrupt Structure	None	a) 2 Non Vectored Interrupts on P I A b) 2 Vectored S W I & N M I c) Total of 4 Non Prioritized Interrupts
Built In Mini Operating System in ROM For Terminal And Memory Debug	FAIRBUG*	None	MIKBUG*
Loader Program	Automatic Internal ROM	Manual Console Switches	Automatic Internal ROM
Static RAM Memory	1024 BYTES	None	2048 BYTES
Card Rack	Rugged Alum. Self Contained Card Rack/Plastic Self Aligning Card Guides	Card Supports	None
Auxiliary DC Power To Power Peripherals	+5V, -5V, +12V, -12V @ 1 Amp. Ea. Regulated At Rear Panel Terminal Strip	None	None
Basic Kit Price	\$459.00	\$539.00, \$599.00 or \$840.00 Depending On System	\$395.00

OUR 4K STATIC RAM BOARD FEATURES: (OPTIONAL)

- On board decoding for any four of 64 pages.
- Address and data lines are fully buffered.
- No onboard regulators to cause heat problems. (Chassis mounted)
- 4K memory boards with connector, buffers, static RAM's & sockets are available in kit form

\$149.00

The VERAS System can be made into a 17K processor by merely adding four of our optional memory boards. The kit includes everything you need to build the VERAS F-8 Computer as described. All boards, connectors, switches, discrete components, power supply and cabinet are supplied. Programming manual, data book and simplified support documentation supplied, 8K Assembler and Editor (paper tape or K.C. std. cassette) available on request with minimum order of 8K RAM.

THE VERAS SYSTEM

THE CPU BOARD FEATURES:

- Two I/O ports each on the CPU and ROM chip make 32 bidirectional TTI lines.
- The Fairbug* programmed storage unit provides the programmer with all I/O subroutines, allows the programmer to alter or display memory, and register its contents via teletype.
- Programmable internal timer is built into the ROM chip.
- Built in clock generator and power on reset are built into the CPU chip.
- There is a local interrupt with automatic address vector.
- It is expandable to 65K bytes of memory.
- 20 mil loop and/or RS232 interface included.
- 1K of on board 2102 RAM.
- Serial interface built into PSU chip.

*Fairbug is a registered trademark of Fairchild Corp.

TINY 2 K BASIC (AVAILABLE) OCT. 15, 1976 \$25.00
FULL BASIC (AVAILABLE) DEC. 15, 1976 \$50.00

Computer dealers and hobbyist club inquiries are invited. Expected delivery time 30 days or less.

The More Flexible and Expandable Computer at a Comparative Price.

VERAS SYSTEMS

Warranty: 90 days on parts and labor for assembled units. 90 days on parts for kits. Prices, specifications, and delivery subject to change without notice.

VERAS SYSTEMS
A Div. of Solid State Sales, Inc.
Box 74B, Somerville, MA 02143
(617) 547-1461

Enclosed is check for \$ _____

or Master Charge # _____

VERAS F-8 Computer Kit Assembled
 4K RAM Board Quantity _____

Name _____

Address _____

City, State _____ Zip _____

```

MOV     A,E
ADI     04H      ;INCREMENT THIRD BIT OF E
MOV     E,A
MOV     A,C      ;SUB 64 FROM C
SBI     40H
MOV     C,A
QUADU: MOV     A,B      ;GET X AGAIN
RRC     ;DIVIDE BY 2
RAR     ;DIVIDE BY 2 AGAIN
MOV     B,A      ;STORE IN B
MVI     A,0      ;CLEAR A
ADC     A        ;PUT CARRY IN A
MOV     D,A      ;STORE CARRY IN D
MOV     A,B      ;GET X/4 AGAIN
ANI     0FH      ;LOOSE HIGHER HALF-WORD
MOV     B,A      ;SAVE IN B
MOV     A,C      ;GET Y AGAIN
RLC     ;MULTIPLY BY 8
RLC
RAL
JNC     LOWER   ;IF NO CARRY, DONT INCREMENT E
INR     E
LOWER: ANI     0F0H   ;DUMP LOWER HALF-WORD
ADD     B      ;ADD X DISPLACEMENT
MOV     L,A    ;LOAD L
MOV     H,E    ;LOAD H
RET

```

Selecting the Color of the Crayon

We decided to let the user select the desired color and intensity by moving the switches for the lower four bits of the "programmed input" register on the IMSAI 8080 front panel. (If the switches are all off, zeros will be written into memory, which gives the "black" color.) We must also know into which half of Dazzler byte location we should put this color information. This is determined by the state of the carry bit which was saved in register D, when X was divided by 4 in the algorithm for address calculation. For example, X = 40 and X = 42 will translate into the same address. But X = 42 will set the carry bit, causing the most significant half of the word to be used, while X = 40 won't, causing the least significant half to be used. A program sequence to accomplish this would be:

1. Read switch registers.
2. Mask out the most significant half word.
3. Store in C.
If D = 0, get word in location referenced by H,L. Then zero least significant half and "OR" the result with C.
4. If D = 1, rotate C 4 times, get word referenced by H,L. Then zero most significant half, and "OR" the result with C.
5. Move result back to memory.

The above manipulations are taken care of in the main program which we show assembled in listing 1 along with all the subroutines needed.

The Final Program

The final Cybernetic Crayon program consists of a "main program" (which is actually not very long), and three sub-

routines. The main program handles a few minor tasks (like turning the Dazzler on, and selecting a color), and also calls the subroutines as needed.

For example, in order to get X and Y from the digitizer, it must "read" each value separately from the appropriate input ports (in our program X is read from port 10, and Y from 11). These values must be decoded, and stored in two of the registers of the microcomputer. Thus, once the digitizer is connected to the two parallel ports as described, all that is needed to read and decode each coordinate is an input statement followed by a call to the "DECODING" routine. We can accomplish this task as follows:

1. Input from X port to accumulator and complement.
2. Call decode routine.
3. Move result to B register.
4. Input from Y port to accumulator and complement.
5. Call decode routine.
6. Move result to C register.

This segment is found at addresses 0019 to 0027, with the H register used as a temporary copy of the X value. All our programs were written in 8080 assembly language. For those readers who don't have an assembler, a machine language translation is also shown. This was produced by a cross-assembler written in BASIC-PLUS by Don Simon of Soloworks.

Some Ideas for Extending and Applying the Cybernetic Crayon

Extensions that we are working on include a blinking cursor, superimposing pictures from two digitizers, subpictures, moving pictures, and games that allow human interaction. Some of these may exceed the capabilities of a single processor, which suggests that several processors with shared memory is an idea worth exploring.

The principal application we have in mind is to education, but not in the sense of what is called "CAI" (computer assisted instruction). CAI says that computers should be used to "teach" children. We think that anyone who has used computers knows that it should be the other way around. One of the best ways to learn something is for the student to try to "teach" it to a critical audience. What more critical (but fair) audience can you find than a computer?

Another deep idea about human learning that comes out of letting people play with

computers (as opposed to using computers as Skinnerian teaching machines) is that real computing helps build a rich background of experiences. This is educationally valuable because people with lots of experiences are *much* better audiences for lectures and books. For example, a young child who has played with the Cybernetic Crayon will surely get a lot more out of a math book that explains Cartesian coordinate systems than one who reads the same book cold.

Computers are revolutionary for education, not because they can "automate" teaching, but because they make it possible to undo a serious mistake. Present educa-

tional practice is basically upside down. It says to young children "listen to, and memorize all this stuff because some day you'll do great things with it." How much better it would be if we could let kids *do* great things first, and *then* explain how it all worked. The followup would be to show how even better things could be done with new information. The power of computers is that they make such a strategy not only possible, but workable in a way that makes learning the adventure it ought to be. This is why the personal computing movement has much to contribute to the future of education. ■

The use of this system can lead to quite practical results for the artist. What called the Crayon System to our attention and resulted in this article was Margot Critchfield's first entry into the BYTE Computer Art Contest, the pastoral scene, photo 7. Here are several of the Art Contest entries which Margot Critchfield has created using the Cybernetic Crayon system described by this article. The comments are based on Margot's notes with direct quotes as indicated.

Using Computer Graphics as a Medium for Artistic Expression: A Portfolio of Explorations

By

Margot Critchfield
Project Solo
311 Alumni Hall
University of Pittsburgh
Pittsburgh PA 15260

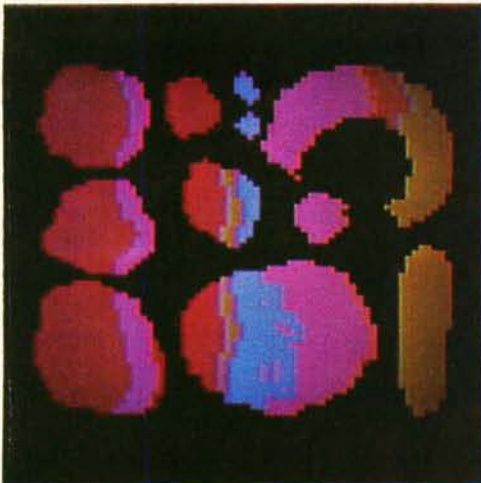

Photo 1: Fruit Salad. The background of warm colors in vertical stripes was created first. Then the shapes were created in Erase mode, after which the stripes were modified to echo the shapes.

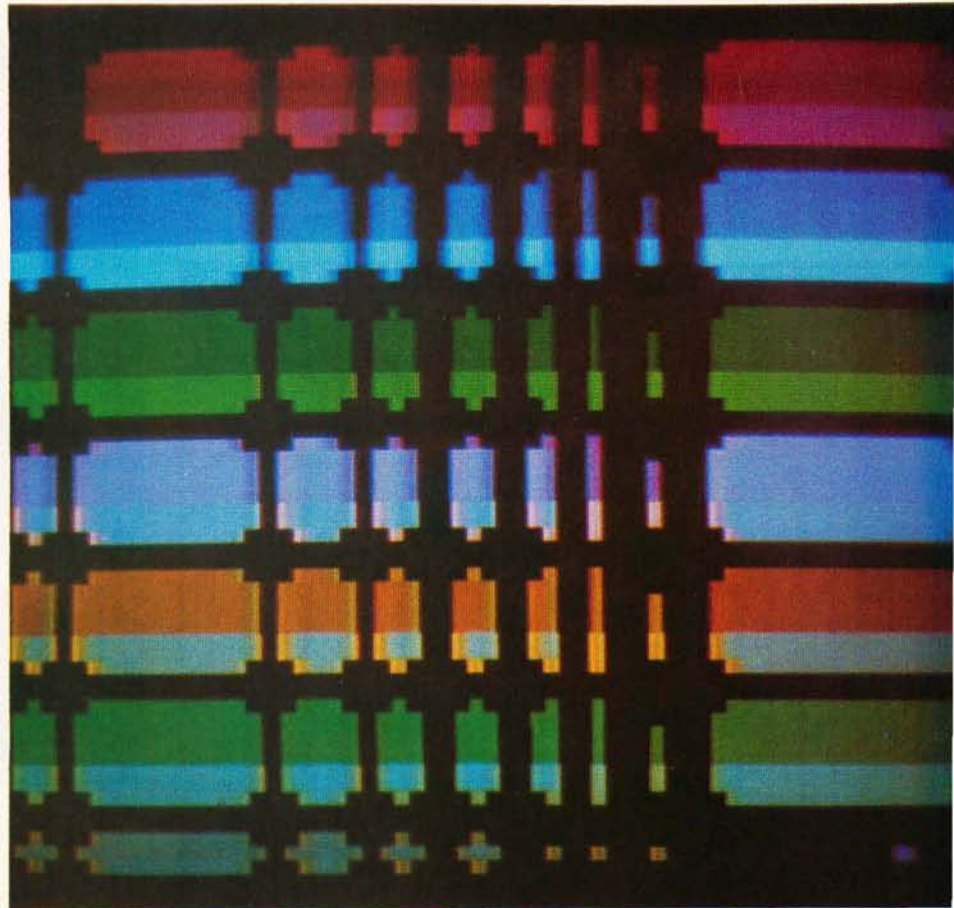

Photo 2: Framework. The background of all possible colors was done first in horizontal stripes. Then the framework and "joints" were done in Erase mode.

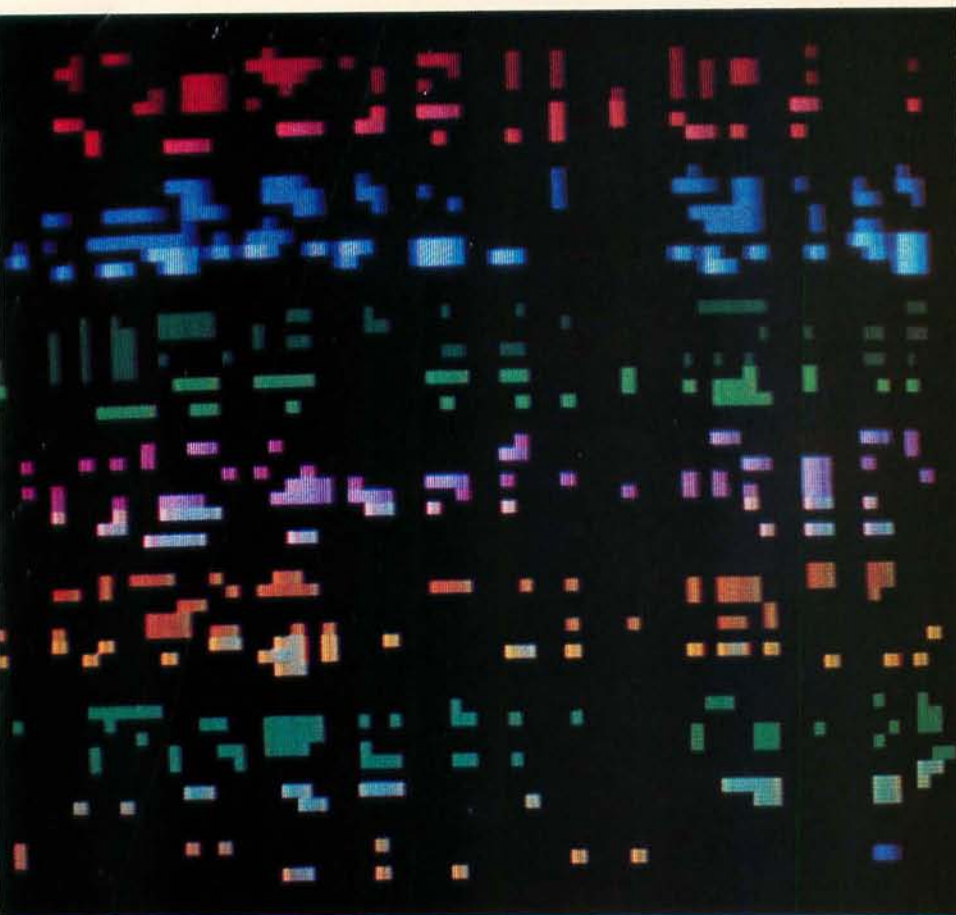

Photo 3: Modern Stained Glass. The framework of photo 2, modified by further erasures.

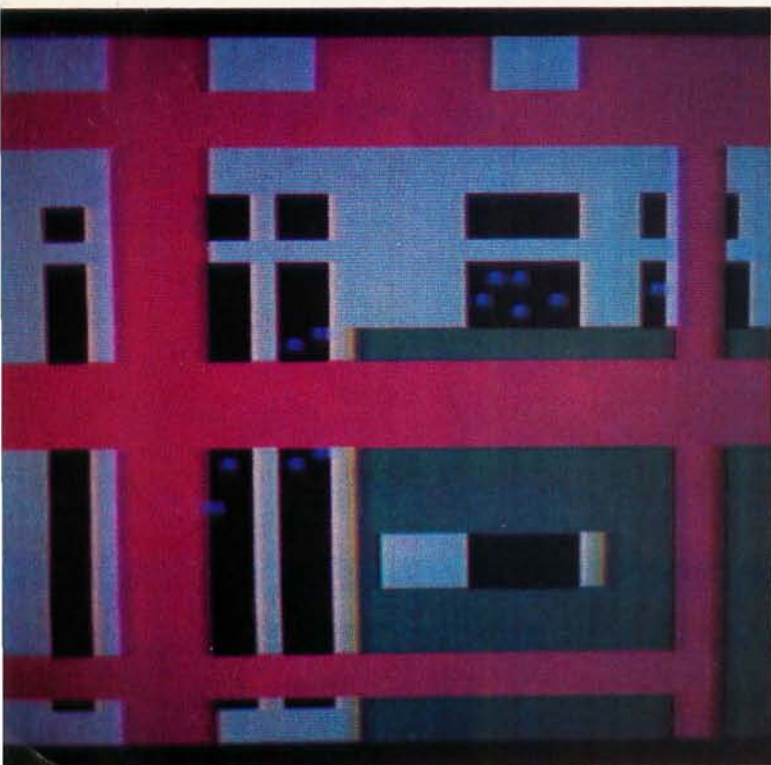

Photo 5: Windows and Spaces. This picture is restricted to horizontal and vertical contours. It achieves a dreamlike quality, with an illusion of overlapping forms.

Photo 4: Psychedelic Cat. This picture is an attempt to photograph a frame attached to the front of the television set. Margot writes "This is an attempt to work in a more traditional or painterly way with the digitizer. It involves a good deal of patience and much switching back and forth between colors. By this time I had more or less memorized the switches."

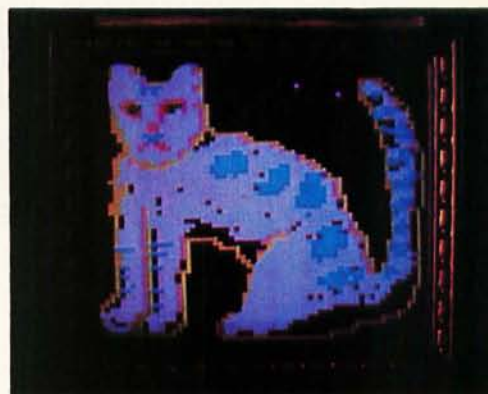

Photo 6: Patriotic Motif. "A predrawn map of the US was traced with the digitizer on a blue background then filled in. Initials were done in Erase mode."

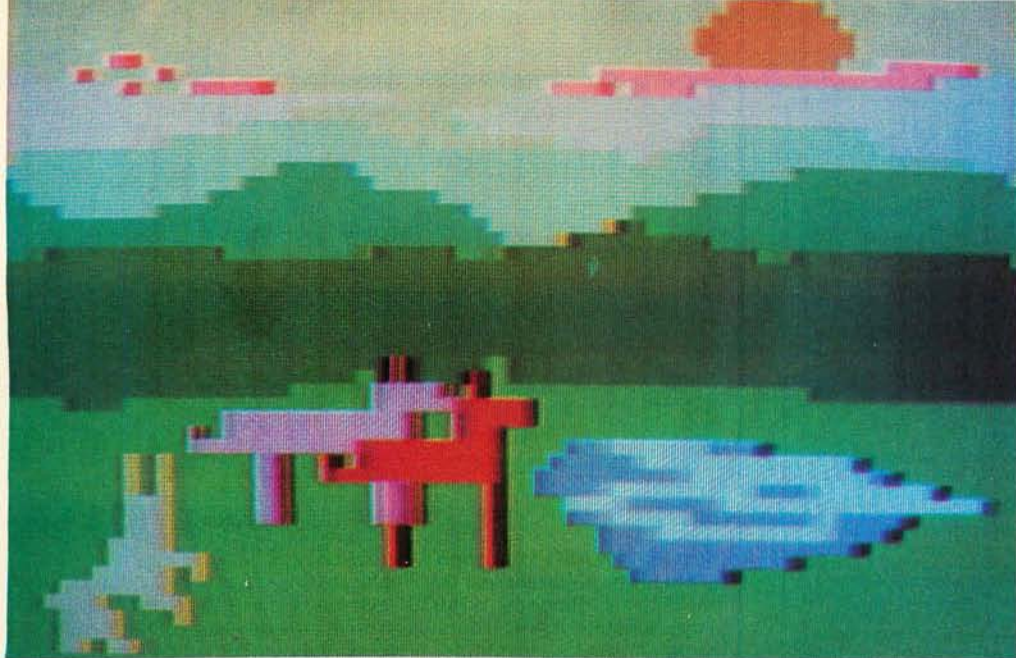
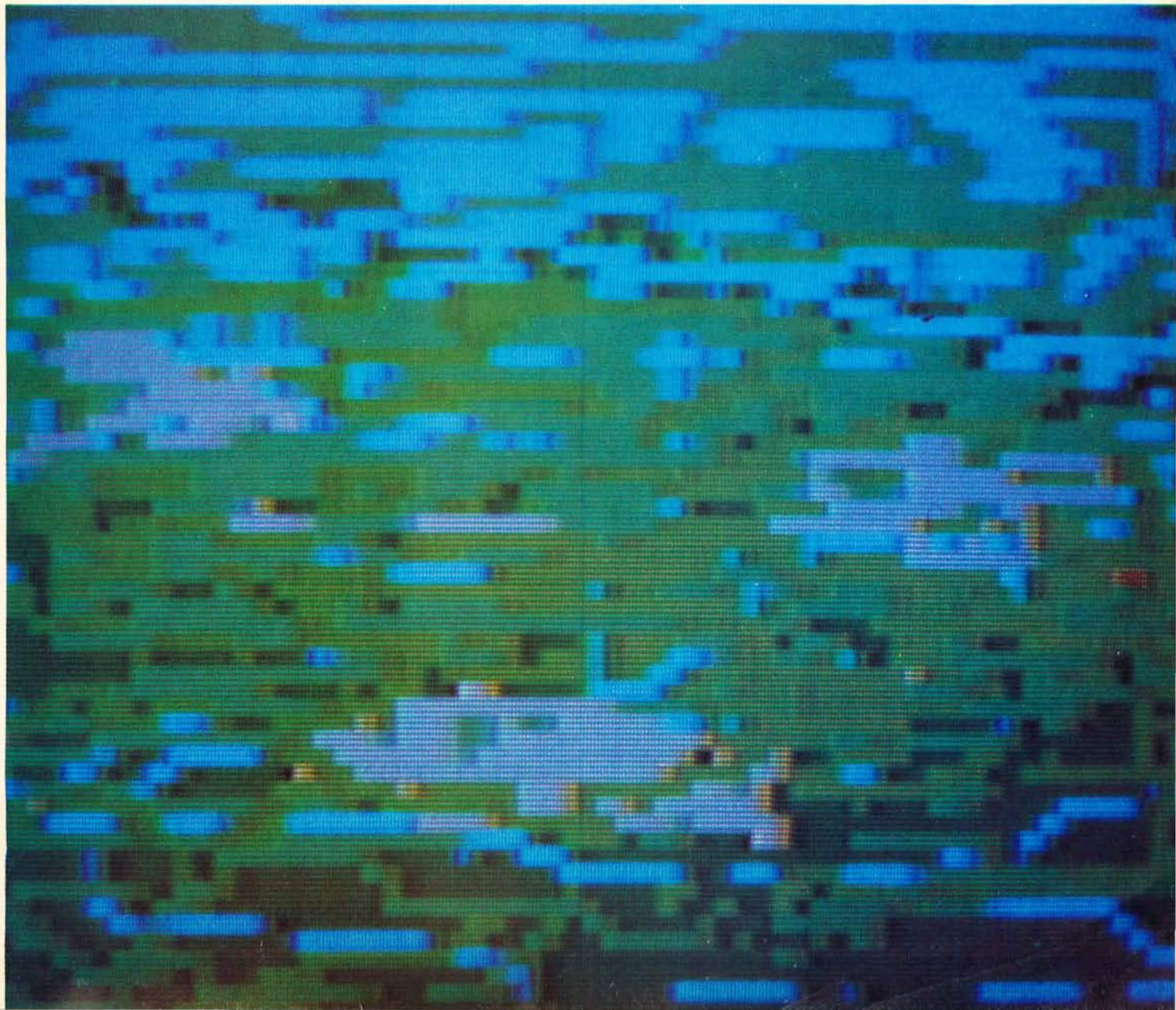

Photo 7: Pastoral Scene or Ferocious Rabbit Attacking Two Horses at a Pond While the Sun Sinks Slowly Behind the Hills. The background of this image was drawn first, then the animals were added. There is a childlike quality (naturally) since a visiting 5 year old drew the horse.

Photo 8: Lily Pond. "With apologies to Monet. The attempt here is to approximate soft contours, impressionist type color mixtures. Looks good through an out of focus projector lens."



THE SC/MP AT \$95.00

SC/MP, the Microprocessor kit from National Semiconductor includes everything you need to build a completely functional microprocessor system — featuring the National SC/MP microprocessor — the low cost microprocessor for every application: Text Systems and Instrument Control; Machine Tool Control; Small Business Machines; Word Processing Systems; Educational Systems; Multiprocessor Systems; Process Controllers; Terminal Control; Laboratory Instrumentation; Sophisticated Games; Automotive Controller and Appliance Controllers.

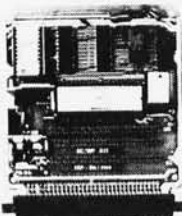

The kit, neatly packaged with all the components and literature you need, in a looseleaf binder, includes: The SC/MP Microprocessor — a single-chip Central Processing Unit in a 40-pin, dual in-line package. Features static operations, forty-six instruction types; single-byte and double-byte, software controlled interrupt structure, built in serial input/output ports; bidirectional 8-bit TRI-STATE^R bus, parallel data/port and latched 12-bit TRI-STATE^R address port. ROM — 512 bytes (8-bits/byte) of pre-programmed Read-Only-Memory containing KITBUG—a monitor and debugging program to assist in the development of your application programs, KITBUG provides teletypewriter input/output routines and allows examination, modification, and controlled execution of your programs. RAM-256 bytes of static read/write memory for storage of your application programs. Transfers of data to and from RAM are controlled by SC/MP and KITBUG. Teletypewriter Interface including buffer and drive capability for a 20 MA current loop interface. Voltage Regulator. Data Buffer—providing interface between memory and bidirectional data lines. All the literature you need, including schematics and programming manuals. Timing Crystal—providing 1.000 MHz timing signal. Plus all the passive components and circuit board with 72 pin edge connector required to build and interconnect your microprocessor system with external hardware.

KEYBOARD ENCODER CHIP \$14.95

G.i. AG-5-3600 ASCII Programmed

SWITCHES

10 Position rotary switch
by oak manuf. \$1.00 per 4



8 position, 1 off switch in TO5 can
\$.69 2 for \$1.00



ROCKER SWITCH

SPST normally open contact rating 6A 250VAC
solder \$.50 ea \$2.00 per 6



MINIATURE TOGGLE SWITCH SPST P.C. MOUNT \$.99



I.C.'s

DM 7092 (8092) Dual 5 input N and Gate \$1.00 per 3

DM 7094 (74126) Tri State Quad Buffer \$1.00 per 3

Mismarked I.C.S. (marked 64xx instead of 74xx)

7408 \$1.00 per 10

74192 \$1.00 per 2

I.C. SOCKET 4 for \$1.00 Limit 12 per customer.
14 pin wire wrap

BRIDGES

12A 50V* \$1.40 ea \$12.00 per 10

25A 50V* \$1.60 ea \$14.40 per 10

*Were tested to 50V. Many may be good for 600-800V.

All prices effective through DEC. 30th.

ASC II KEYBOARD



(Reg. \$58.85)

\$53.00

This 63 key ASC II Encoded Keyboard kit was designed and manufactured by Electronics Warehouse Inc. Features: single 5 volt D.C. supply, utilizing only TTL logic elements (no MOS devices to blow), TTL drive capability (each of the eight bits of ASC II output will drive the equivalent of ten standard TTL inputs without external buffer drivers), de-bouncing, upper and lower case fully ASC II, 8 bit parallel output. In addition to the alpha-numeric and symbol keys available on a regular keyboard, the following keys are utilized: escape, back-space, tab, line-feed, delete, control, shift-lock, shift (2 keys), here-is, control-release.

Kit includes: 63 key keyboard, P.C. board, all required components and assembly manual with ASC II code list.

Optional: 1. Parity bit - add \$1.00
2. Serial output - add \$2.00

Note: If you already have this teletype keyboard you can have the kit without it for \$36.00 (reg. \$39.85). Dealer inquires invited.

7 SEGMENT DISPLAYS - RED

.35" by OPCOA. High Intensity.

With decimal point 4 for \$4.00

Without decimal point 4 for \$3.60

CAPACITORS

28000 MF 10VDC \$1.50

185000 MF 6VDC \$2.00

A.C. Oil cap, 10MF 330VAC \$1.50

CALCULATOR KEYBOARD

4 x 5 MATRIX \$1.95

CENTER TAPPED TRANSFORMER

14V at 1.A \$2.50

28V at .5A

MINIMUM ORDER \$5.00

Shipping & Handling:

KEYBOARD or SC/MP - \$3.00 + \$.50 Insurance

all others - \$1.00

California residents add 6% sales tax.

ELECTRONICS WAREHOUSE Inc.

1603 AVIATION BLVD.

REDONDO BEACH, CA. 90278

TEL. (213) 376-8005

WRITE FOR FREE CATALOG

You are invited to visit our store at the above address

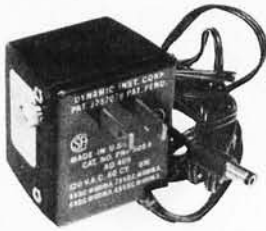

UNIVERSAL POWER SUPPLY

A unique plug-in supply by Panasonic. Useful for calculators, small radios, charging many & various small NiCad batteries. Adjustment screw plug on the side changes output voltage to 4½, 6, 7½, or 9 volts DC at 100 MA. Output cord with plug, 6 ft long.

No. SP-143C \$4.50 3/\$12

POWER SUPPLY

LAMBDA 5VDC 74 AMP

LV-EE-5-OV \$125.00

NJE 5/OUP-D5

5 VDC 32 AMP \$75.00

CLOCK KIT \$14.00

Includes all parts with MM5316 chip, etched & drilled PC board, transformer, everything except case.

SP-284 \$14.00 each 2/\$25.00

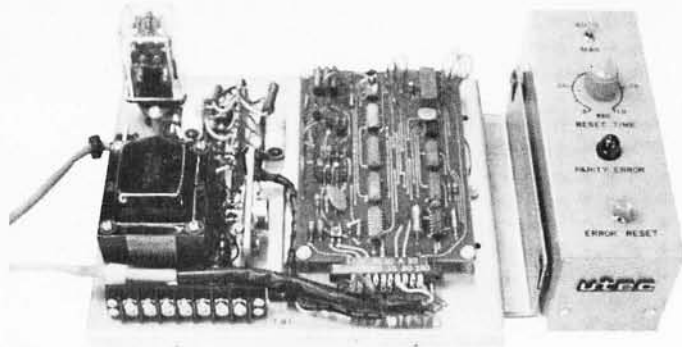

PARITY DETECTOR

New packaged, made for RCA, detects even or odd parity, baud rate 110, 150 or 134.46. Built-in logic supply for the IC's, operates from standard 115 vac. Control panel allows manual or automatic reset mode of operation. Aluminum enclosure (not shown), covers the electronics. TTY compatible.

Ship wt. 10 lbs. \$16.50

COMPUTER DISPLAY TUBE

New Sylvania 9 inch CRT, 85 degree deflection, with tinted faceplate. Same as used in Viatron systems (buy a spare). With complete specs.

Ship wt. 5 lbs. \$15.00

LINEAR by RCA, brand new, gold bond process

301	\$.60	747	\$.82	MM5314	\$3.00
307	.52	748	.50	MM5316	3.00
324	1.80	1458	.96	7001	8.00
339A	1.60	3401	.80		
741	.50	555 timer	.60		

MEMORY SYSTEM \$125.00

New memory system by Honeywell, small ... measures only 9x4x1 inches. 1024 core memory, 1024 words with 8,9,10 bits/word. Random access, with all logic, register, timing, control, core select and sense functions in one package. New, booklet of schematics and data. Looks like a good beginning for a mini-computer. Limited supply on hand.

Ship wt 3 lbs. #SP-79 \$125.00

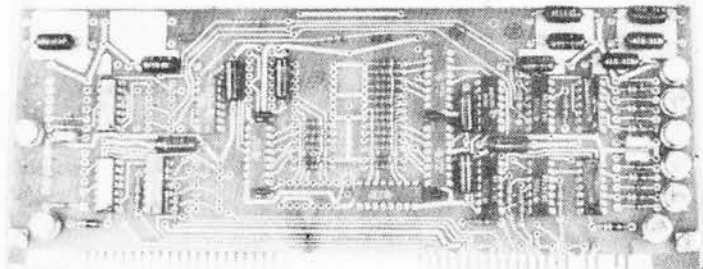

COMPUTER GRADE LOGIC SUPPLY CAPS, BRAND NEW

3 Power supplies, transistorized & regulated. Made by TRANSISTOR DEVICES	47,000 Uf	25V	\$2.00	ST	1,000	50	.90	AL
15 volts DC 5 amps \$25.00	32,000	25	1.75	ST	3,300	35	1.25	AL
30 volts DC 2 amps 25.00	160,000	10	2.00	ST	1,600	20	.60	AL
15 volts DC 4.5 amps 25.00	66,000	10	2.00	ST	8,000	16	1.25	AL
	1,000	60	.90	AL	500	6	.35	AL
	2,000	55	1.00	AL	"ST" screw top	"AL" axial	

Please add shipping cost on above.

PHONE 617-595-2275 FREE CATALOG SP-8 NOW READY
MESHNA PO Bx 62 E. Lynn Mass. 01904

Meshna

BYTE

reader service

To get further information on the products advertised in BYTE, fill out the reader service card with your name and address. Then circle the appropriate numbers for the advertisers you select from this list. Add a 9 cent stamp to the card, then drop it in the mail. Not only do you gain information, but our advertisers are encouraged to use the marketplace provided by BYTE. This helps us bring you a bigger BYTE.

- | | |
|----------------------------------|---|
| A166 Arizona Micro Systems 109 | A119 Midwestern Scientific Inst 61 |
| A107 Audio Design Electronics 84 | A57 Mikos 131 |
| A004 BITS 94, 112, 113 | A112 MiniTerm 79 |
| A149 Bits and Bytes 85 | * MITS CIV, 3, 15 |
| A153 Bits, Bytes and Pieces 109 | A22 National Multiplex 35 |
| A111 Brigar 129 | A150 NECA 89 |
| * BYTE's binders 93 | A155 North Star Computers 93 |
| A126 Cheap, Inc 89 | A40 Ohio Scientific Inst 4 |
| A127 Comptek 89 | A147 OK Tools 39 |
| A207 Comptek 84 | A64 Oliver Audio Engineering 109 |
| A140 Computalker 89 | A63 Parasitic 67 |
| A161 Computer Corner 85 | A85 Per Com Data 53 |
| A143 Computer Enterprises 89 | A23 Polymorphic Systems 40, 41 |
| A83 Computer Mart of NY 109 | A24 Processor Technology 71, 72, 73, 74, 75, 76 |
| A159 Computer Microsystems 85 | A160 RBB Software Products 85 |
| A141 Computer Room 57 | A26 Scelbi 10, 11 |
| A6 Continental Specialties 55 | A27 SD Sales 132, 133 |
| A87 Creative Computing 97 | A169 Smoke Signal Broadcasting 109 |
| A41 Cromemco 1 | A59 Solid State Sales 136, 137 |
| A7 Delta 135 | A29 Southwest Tech CII |
| A78 Digital Group 13 | A30 Sphere CIII |
| A165 Digital Research 49 | A99 STM 80 |
| A162 EEPS 109 | A164 Sunny Computer Store 85 |
| A157 Electronic Warehouse 142 | A96 Synchro Sound 47 |
| A102 Eltron 134 | A82 Technical Design Labs 21 |
| A9 Godbout 123 | A156 Trintronics Ltd 89 |
| A11 Iasis 84 | A32 Tri-Tek 121 |
| A12 IMSAI 8, 22, 23 | A137 Vector Graphic 51 |
| A38 Intelligent Systems 6, 7 | A115 Wilcox 85 |
| A15 James 125, 126, 127 | A42 Wintek 95 |
| A18 Meshna 143 | A154 Worldwide Electronics 49 |
| A71 MPI 91 | |

*Reader service inquiries not solicited. Correspond directly with company.

BOMB: BYTE's Ongoing Monitor Box

BOMB's Beneficence Booms

The winner of the September 1976 BOMB analysis was Calvin Moerrs, author of "Are You an Author." He receives a bonus payment of \$100. Runner up for the September issue was Dr Robert Suding, who wrote "The Circuit for Z-80s." Dr Suding receives a bonus check of \$50 for his work.

Effective this month, we're increasing the BOMB bonus amount to \$100 for the author receiving the highest rating, \$50 for the author who places second in the tally of BOMB points. Be sure to send in your rating of BYTE authors, since it is a way of providing feedback to them on the quality of their work. ■

PAGE	ARTICLE	LIKED										
		LEAST	0	1	2	3	4	5	6	7	8	9
12	Banks-Sanderson: Machine Readable Software	0	1	2	3	4	5	6	7	8	9	10
18	Regli: Software for Reading Bar Codes	0	1	2	3	4	5	6	7	8	9	10
24	Dwyer-Sweer: Cybernetic Crayon	0	1	2	3	4	5	6	7	8	9	10
30	Penn: Buried Gold in the SR-52	0	1	2	3	4	5	6	7	8	9	10
36	Anderson: Processor Tech VDM-1	0	1	2	3	4	5	6	7	8	9	10
42	Henshaw: Stretch That 6800 Clock	0	1	2	3	4	5	6	7	8	9	10
58	Baker: Don't Waste Memory Space	0	1	2	3	4	5	6	7	8	9	10
62	Firth: Do It Yourself Weather Predictions	0	1	2	3	4	5	6	7	8	9	10
77	Merkowitz: Signal Processing . . .	0	1	2	3	4	5	6	7	8	9	10
98	Kay: Designer's Eye View of AC-30	0	1	2	3	4	5	6	7	8	9	10
110	Liming: Building the AC-30 Cassette	0	1	2	3	4	5	6	7	8	9	10
114	Millen: Universal Turing Machine	0	1	2	3	4	5	6	7	8	9	10
139	Critchfield: Portfolio of Explorations	0	1	2	3	4	5	6	7	8	9	10

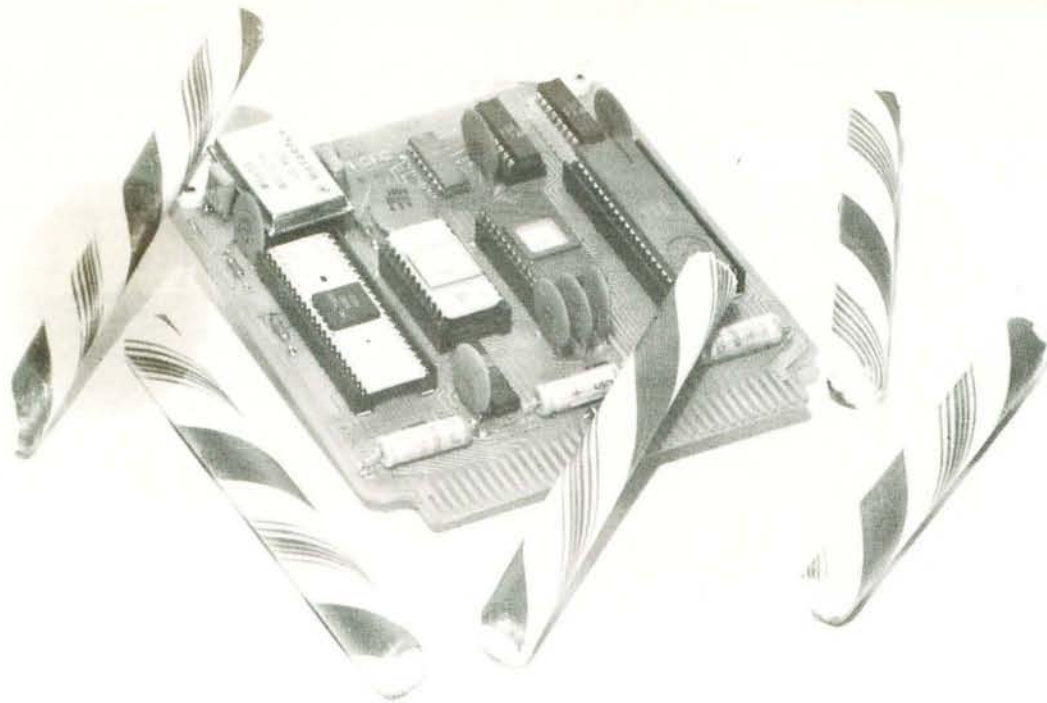

WHAT a SWEET DEAL!

Programmable Microprocessor Controller!

\$194.⁰⁰

The Sphere TPU/1 micro computer on a card is designed for use in control environments; whether it be personal or business. TPU is an expandable CPU on a 4.4X4.9 inch edge connector board with the Motorola 6800 microprocessor, a 6820 parallel interface, 256 or 512 bytes of EPROM, 2048 bits of static RAM and a crystal controlled clock driver. You can program the read only memory with special instructions to meet your own needs or buy our prog-

rammed ROM'S. The static memory is expandable to 32K and you can control teletype or other I/O.

The TPU has a 72 pin edge connector with all the necessary signals to interface to almost any device. Use it to operate your sprinkling system, lights, heating/cooling system, security system or even control your electric train. The applications are limitless. The TPU/1 is completely assembled and tested; includes schematics and manual. FOR \$194 ITS ONE SWEET DEAL!



SPHERE
CORPORATION

Dept. 104 P. O. Box 129
Bountiful, Utah 84010

(801) 292-8466

Please send me _____ Sphere CRT interface kits.
Enclosed Check/Mastercharge/Bankamericard

Amount \$ _____ Card No. _____

Name _____

Address _____

City _____ State & Zip _____

Limited offer, prices subject to change • Allow up to 30 days for delivery.

The small wonder



of the micro-world

Measuring just 11" wide x 11" deep x 5" high, and weighing a mere 7 pounds, the Altair™ 680b is a complete, general-purpose computer.

The secret to this revolutionary, small computer is its CPU board. This double-sided board fits along the bottom of the Altair case and plugs directly into the front panel board. It contains the new 6800 microprocessor, 1,024 bytes of RAM memory, a 256 byte PROM monitor, provisions for 768 bytes of additional PROM or ROM, and a single Interface port with a Motorola ACIA serial interface adapter which can be configured either RS-232 or TTY. A five level Baudot interface option is also available.

The Altair 680b can be programmed from front panel switches, or it can be interfaced to a video display terminal, or teletypewriter. Three additional circuit boards can be plugged inside the Altair 680b for further memory and interface expansion. The first of these boards is a 16K static RAM memory board.

Software already developed includes Altair 680 BASIC with all the features of the 8K BASIC previously developed for the Altair 8800. These include Boolean operators, the ability to read or write a byte from any I/O port or memory location, multiple statements per line, and the ability to interrupt program execution and then continue after the examination of variable values. This software takes only 6.8K bytes of memory space and a copy is included free with the purchase of the Altair 680 16K memory board.

Other software includes a resident two pass assembler. The Altair 680b is also compatible with Motorola 6800 software.

The Altair 680b is ideal for hobbyists who want a powerful computer system at an economic price. Altair 680b owners qualify

for membership in the Altair Users Group, and like other Altair owners, they receive a complimentary subscription to **Computer Notes** and complete factory support.

PRICES:

Altair 680b kit with complete, easy-to-understand assembly manual, operator's manual, and programming manual.....	\$466
Assembled Altair 680b.....	\$625
Altair 680b Turnkey model kit.....	395
Expander Card 680MB (required to expand 680).....	\$ 24
Altair 680BSM 16K static RAM board kit with 680 BASIC.....	\$685
Altair 680 BASIC when purchased separately.....	\$200
Baudot option.....	\$ 42

MAIL THIS COUPON TODAY

- Enclosed is a check for \$_____
- BankAmericard # _____ or Master Charge # _____
- Altair 680b Kit Assembled Other (specify) _____
- enclose \$8 for postage and handling
- Please send free information package.

NAME _____

ADDRESS _____

CITY _____ STATE & ZIP _____



2450 Alamo SE/Albuquerque, NM 87106, 505-243-7821

NOTE: Altair is a trademark of MITS, Inc.

Price, specifications subject to change. Please allow up to 60 days for delivery.